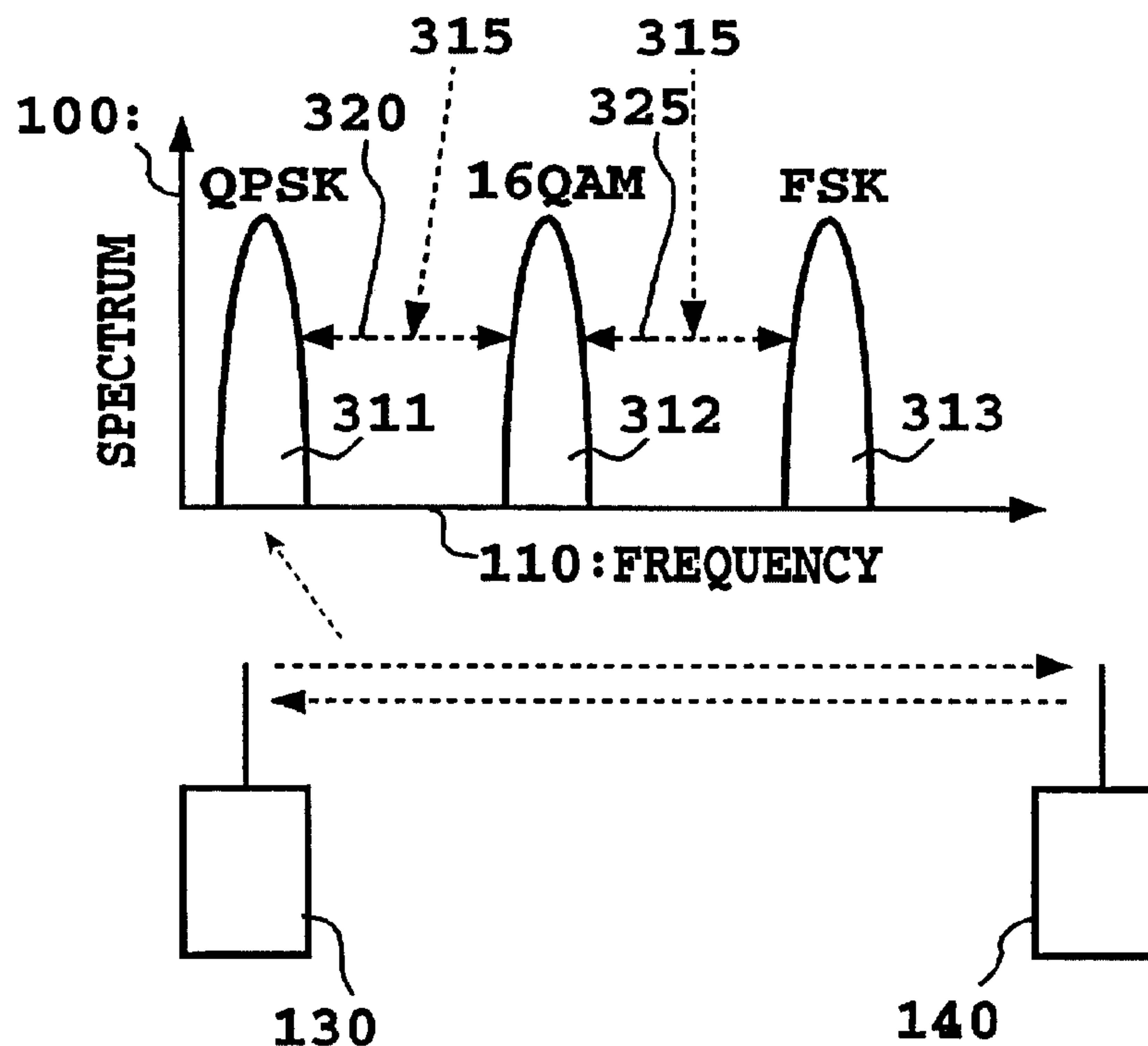




(86) Date de dépôt PCT/PCT Filing Date: 1999/01/07  
 (87) Date publication PCT/PCT Publication Date: 1999/07/15  
 (45) Date de délivrance/Issue Date: 2006/03/21  
 (85) Entrée phase nationale/National Entry: 1999/09/08  
 (86) N° demande PCT/PCT Application No.: JP 1999/000022  
 (87) N° publication PCT/PCT Publication No.: 1999/035772  
 (30) Priorité/Priority: 1998/01/09 (003,525/1998) JP

(51) Cl.Int./Int.Cl. *H04J 1/00* (2006.01)  
 (72) Inventeurs/Inventors:  
 SUZUKI, YASUNORI, JP;  
 NOJIMA, TOSHIO, JP  
 (73) Propriétaire/Owner:  
 NTT MOBILE COMMUNICATIONS NETWORK INC., JP  
 (74) Agent: MCCARTHY TETRAULT LLP

(54) Titre : PROCÉDE DE TRANSMISSION EN PARALLELE  
 (54) Title: PARALLEL TRANSMISSION METHOD



(57) Abrégé/Abstract:

The intervals (120, 125) between the spectra (111, 112, 113) of carrier waves are greater than or around the coherent bandwidth, and hence the carrier waves can receive mutual correlative phasing. Therefore, even if the spectrum (112) receives phasing by a specific carrier wave during call and consequently the line quality degrades, the call can be continued by the other spectra (111, 113). In this case, the other received signals are synchronously detected and combined by a maximum ratio composite method, and carriers can be regarded as independent of each other. Therefore, diversity reception by a maximum ratio composite method of branches, the number of which is equal to the number of carriers used for communication, is possible. Since the intervals between the frequencies are so set by using existing circuit techniques that the carriers are almost mutually in correlation, no radio circuit having frequency characteristics of wide band nor processor for high-degree digital signal processing is needed.



(51) 国際特許分類6 <b>H04J 1/00</b>	<b>A1</b>	(11) 国際公開番号 <b>WO99/35772</b>  (43) 国際公開日 1999年7月15日(15.07.99)
----------------------------------	-----------	--

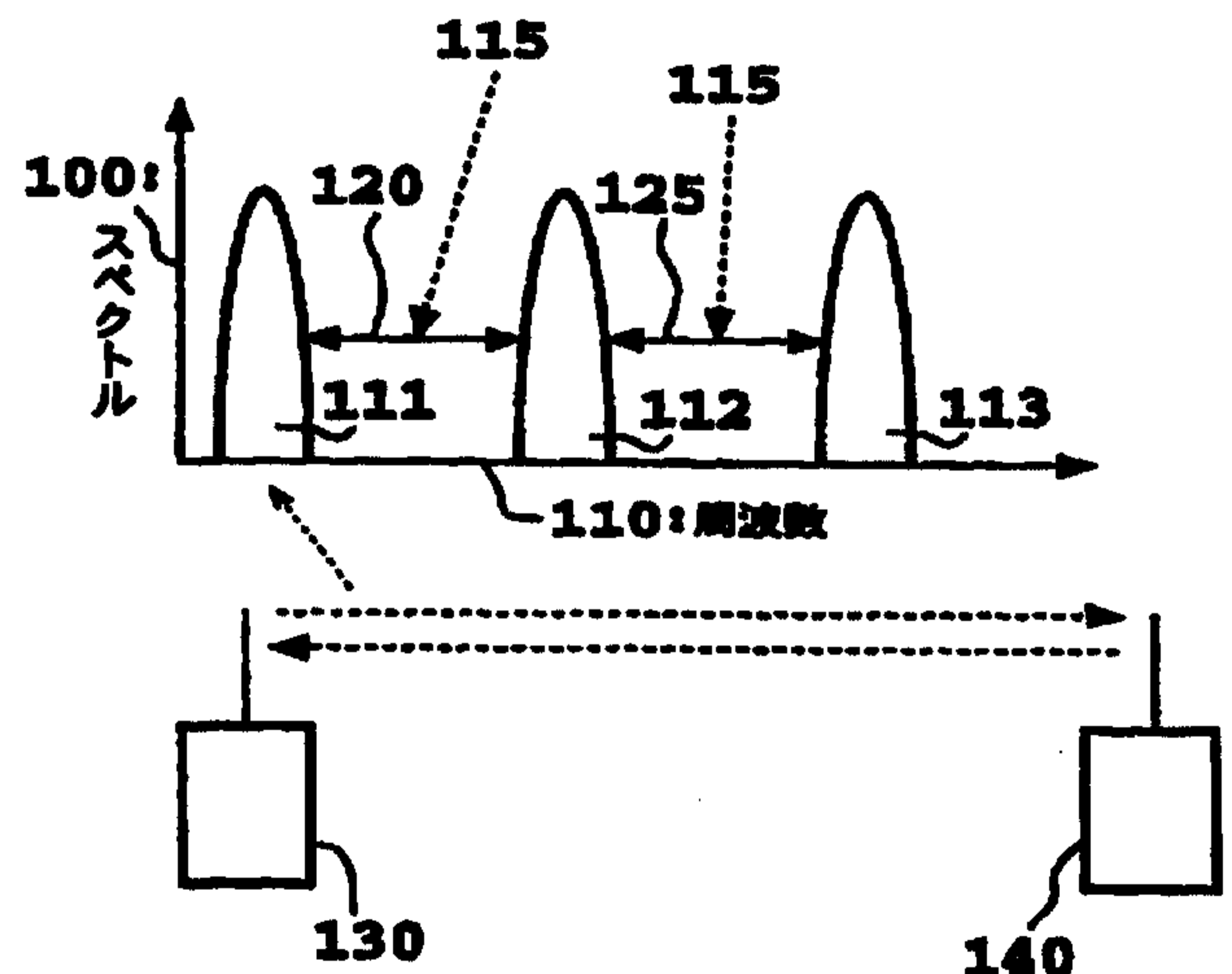
(21) 国際出願番号 PCT/JP99/00022  (22) 国際出願日 1999年1月7日(07.01.99)  (30) 優先権データ 特願平10/3525                      1998年1月9日(09.01.98)                      JP  (71) 出願人 (米国を除くすべての指定国について) エヌ・ティ・ティ移動通信網株式会社 (NTT MOBILE COMMUNICATIONS NETWORK INC.)[JP/JP] 〒105-8436 東京都港区虎ノ門二丁目10番1号 Tokyo, (JP) (72) 発明者 ; および (75) 発明者 / 出願人 (米国についてのみ) 鈴木恭宜(SUZUKI, Yasunori)[JP/JP] 〒231-0023 神奈川県横浜市中区山下町112-4 ポートヴィラ元町804 Kanagawa, (JP) 野島俊雄(NOJIMA, Toshio)[JP/JP] 〒239-0833 神奈川県横須賀市ハイランド2-25-13 Kanagawa, (JP) (74) 代理人 弁理士 谷 義一(TANI, Yoshikazu) 〒107-0052 東京都港区赤坂2丁目6-20 Tokyo, (JP)	(81) 指定国    CA, US.  添付公開書類 国際調査報告書
--	--

(54)Title: **PARALLEL TRANSMISSION METHOD**

(54)発明の名称 並列伝送方法

(57) Abstract

The intervals (120, 125) between the spectra (111, 112, 113) of carrier waves are greater than or around the coherent bandwidth, and hence the carrier waves can receive mutual correlative phasing. Therefore, even if the spectrum (112) receives phasing by a specific carrier wave during call and consequently the line quality degrades, the call can be continued by the other spectra (111, 113). In this case, the other received signals are synchronously detected and combined by a maximum ratio composite method, and carriers can be regarded as independent of each other. Therefore, diversity reception by a maximum ratio composite method of branches, the number of which is equal to the number of carriers used for communication, is possible. Since the intervals between the frequencies are so set by using existing circuit techniques that the carriers are almost mutually in correlation, no radio circuit having frequency characteristics of wide band nor processor for high-degree digital signal processing is needed.



100 ... SPECTRUM  
 110 ... FREQUENCY

## SPECIFICATION

## TITLE OF THE INVENTION

## PARALLEL TRANSMISSION METHOD

5

## TECHNICAL FIELD

The present invention relates to parallel transmission that carries out radio communications using a plurality of carriers for bearing a plurality of baseband signals, and more particularly to a parallel transmission method preferably applied to land mobile communications.

## BACKGROUND ART

15 Recently, various types of radio communication systems, typified by land mobile communications requiring high-speed and high-quality transmission, have been proposed for the purpose of providing high-quality and high-speed transmission. For  
20 example, those systems are proposed such as CDMA (Code Division Multiple Access) systems, adaptive modification systems, 16 QAM (Quadrature Amplitude Modification)-4 multicarrier transmission systems and OFDM (Orthogonal Frequency Division  
25 Multiplexing) systems.

Methods employed for ensuring the intended

transmission quality in these radio transmission systems utilizes the error detection techniques that are applied to the second generation mobile communications systems such as PDC (Personal Digital Cellular), GSM (Global System for Mobile  
5 communication) and IS (Interim Standard)-95, or the diversity techniques that are applied to fixed microwave circuits, such as frequency diversity, space diversity and polarization diversity.

10 In the high-speed transmission, are known such systems as adaptive modulation systems that select optimum modulation methods in response to the state of transmission paths, wideband CDMA systems, and OFDM systems which are now being studied to be  
15 applied to digital broadcast.

The above-mentioned high-speed and high-quality transmission systems divide a single spectrum into a plurality of carriers, or apply the error correction technique or diversity technique to a wideband  
20 single carrier. Implementing radio equipment applied to these systems requires radio frequency devices with prescribed frequency characteristics over wide range, and processors for carrying out highly performance digital signal processing. For  
25 example, radio frequency devices such as filters and transmission power amplifiers, and processors such

as error correcting decoders are required.

To realize radio communications systems with highly frequency usage efficiency, radio frequency device techniques for reducing frequency guard bands  
5 between adjacent frequencies are indispensable. Above all, the radio circuit techniques are essential which improves the out-band attenuation characteristics of the filters and the linearity of the transmission systems.

10 Thus, advanced radio frequency device technologies are required to achieve the high-speed and high-quality transmission, and to provide the radio communications systems with highly frequency usage efficiency. For example, information  
15 transmission rate at 10 Mbps requires a frequency bandwidth of 7.5 MHz in the case where the modulation scheme is QPSK and the roll-off filter coefficient is 0.5. To transmit it with a single carrier, it is necessary for the radio equipment to  
20 use receiving filters with a pass-band width (3 dB bandwidth) of 4.6 MHz. Assuming that the adjacent channel attenuation amount of 80dB is necessary for the mobile station to be free from the adjacent channel interference caused by adjacent carriers,  
25 the receiving filters must have a broad pass-band width and sharp attenuation characteristics. Thus,

developing filters with higher performance and smaller size than conventional filters is required to realize light-weight, small size radio equipment.

As described above, the conventional high-speed and high-quality transmission systems divide the single spectrum into a plurality of carriers, or apply the error correction techniques or diversity techniques to a wideband single carrier. To implement radio equipment applied to these systems, radio frequency devices with wideband frequency characteristics and processors for carrying out highly performance digital signal processing are necessary.

The present invention is to solve the foregoing problems. Therefore, an object of the present invention is to provide a parallel transmission method that can realize high-speed and high-quality transmission without employing the radio frequency devices with wideband frequency characteristics and the processors for performing advanced digital signal processing, by carrying out communications by establishing frequency intervals of a plurality of carriers at a value greater than or approximately equal to the coherent bandwidth by using existing device techniques.

## SUMMARY OF THE INVENTION

The parallel transmission method in accordance with the present invention is a parallel transmission method for carrying out radio communications of M different baseband signals using M carriers, where M is an integer greater than one, and characterized, in that it performs communications by establishing frequency intervals between the M carriers at a value equal to or greater than a coherent bandwidth, or at a value approximately equal to the coherent bandwidth.

In the parallel transmission method whose frequency intervals are thus established, the M carriers can be modulated by M or less different modulation methods.

The M or less different modulation methods can each be a combination including at least one of PSK, QAM and FSK.

The combinations of the PSK, QAM and FSK modulation methods can each be a combination thereof or can each include a combination of multivalued modulation of each of the modulation methods. This means that three carrier radio communications employing either 16 QAM, QPSK and 4 FSK or 256 QAM, 16 QPSK and 64 QAM can be used, for example.

Thus, the M or less different modulation methods

can be selected from the multivalued modulation schemes of the QAM, PSK, FSK.

The parallel transmission method in accordance with the present invention can realize the high-  
5 speed and high-quality transmission without requiring the radio frequency devices with wideband frequency characteristics and processors for performing advanced digital signal processing, by carrying out communications by establishing  
10 frequency intervals of a plurality of carriers at a value greater than or approximately equal to the coherent bandwidth using existing circuit techniques.

#### 15 BRIEF DESCRIPTION OF THE DRAWINGS

Figure 1 is a diagram showing an embodiment in which the frequency intervals are established at a value equal to or greater than the coherent bandwidth;

20 Figure 2 is a diagram showing an embodiment in which the frequency intervals are established at a value approximately equal to the coherent bandwidth;

Figure 3 is a diagram showing an embodiment utilizing a plurality of modulation methods;

25 Figure 4 is a diagram showing another embodiment utilizing a plurality of modulation methods;

Figure 5 is a diagram showing carriers whose frequency intervals are standardized by PDC;

Figure 6 is a diagram showing an embodiment in which the present invention is applied to broadcast  
5 communications;

Figure 7 is a diagram showing an embodiment in which voice transmission is mixed with data transmission;

Figure 8 is a block diagram showing a  
10 configuration of a transmitter in accordance with the present invention;

Figure 9 is a block diagram showing another configuration of a transmitter in accordance with the present invention; and

15 Figure 10 is a block diagram showing a configuration of a receiver in accordance with the present invention.

#### BEST MODE FOR CARRYING OUT THE INVENTION

20 First, the outline of the parallel transmission method in accordance with the present invention will be described. In the parallel transmission method in accordance with the present invention, which is the multicarrier radio communications method  
25 enabling the high-speed transmission, the frequency correlation values between carriers are determined

equal to or less than a particular value. For example, the frequency correlation values between the carriers are determined such that the frequency intervals between carriers become equal to or  
 5 greater than the coherent bandwidth at which the correlation is nearly negligible. Here, it is known that the frequency correlation value  $\rho(\Omega)$  can be expressed as equation (1).

$$10 \quad \rho(\Omega) = \frac{1}{1 + j2\pi\Omega\left(\frac{\Delta l}{c}\right)} \exp(j2\pi\frac{l_0}{c}) \quad \dots (1)$$

where, under the assumption that respective intensities of element waves incoming to a receiving station are substantially the same (a group of a  
 15 plurality of element waves forms a fading received wave),  $f_1$  and  $f_1 + \Omega$  are frequencies of two fading received waves;  $\Delta l$  is the dispersion of the length of propagation paths;  $l_0$  is the length of a shortest propagation path; and  $c$  is the velocity of light.

20 The coherent bandwidth is defined as the frequency interval  $\Omega$  at which  $|\rho(\Omega)|$  becomes 0.5. Generally speaking, it is known that the frequency interval  $\Omega$  at which the correlation is nearly negligible is such  $\Omega$  that gives  $\rho(\Omega) \leq 0.5$ .

25 In the parallel transmission method in

accordance with the present invention, even if some carriers cannot provide prescribed transmission quality because of fluctuations in propagation paths such as fading, the degradation in the transmission quality of the radio channels as a whole is avoidable. As a result, compared with the conventional parallel transmission method such as frequency division multiplexing that combines a plurality of carriers into a single spectrum, the parallel transmission method in accordance with the present invention is more resistant to the degradation in the transmission quality in the transmission path with maintaining the data transmission capacity.

Since the frequency intervals of the carriers are separated apart at such values as the correlation is considered to be nearly negligible, the radio frequency devices in accordance with the present invention can be implemented by installing a plurality of radio frequency devices with different local oscillation frequencies. The filters with wide pass-band required by the conventional parallel transmission become unnecessary. It is sufficient for each radio frequency device to achieve its own linearity independently, so that the wideband linearity required by the radio frequency devices in

the conventional parallel transmission becomes unnecessary. As for the processors for carrying out the digital signal processing, lower performance processors can be utilized by employing narrow band carriers, which serves to reduce the power consumption in the digital circuits.

The embodiments in accordance with the present invention will now be described with reference to the accompanying drawings.

Figure 8 is a block diagram showing a configuration of a transmitter used in the parallel transmission method in accordance with the present invention.

In Figure 8, the baseband signals processed by a plurality of baseband processors 800, 805, ... and 810 are D/A converted by D/A converters 820, 825, ... and 830, followed by the quadrature conversions by quadrature modulators 840, 845, ... and 850. Subsequently, frequency converters 860, 865, ... and 870 carry out frequency conversions to  $f_1$ ,  $f_2$ , ... and  $f_N$  through a controller 880. Here, although the conventional parallel transmission method sets the frequency intervals between  $f_1$ ,  $f_2$ , ... and  $f_N$  such that they are approximately equal to each other or that they are equal to or less than the coherent bandwidth, the parallel transmission method in

accordance with the present invention determines them using the controller 880 such that the frequency intervals between  $f_1$ ,  $f_2, \dots$  and  $f_N$  are equal to or greater than the coherent bandwidth.

5 Subsequently, the signals are multiplexed by a signal multiplexer 890, power amplified by a transmission power amplifier 895, and transmitted through an antenna 897.

Figure 9 shows another configuration of the transmitter employed in the parallel transmission method in accordance with the present invention.

In Figure 9, the baseband signals processed by a plurality of baseband processors 900, 905, ... and 910 are multiplexed by a signal multiplexer 915 using a controller 920 such that their frequencies are shifted like  $f_1$ ,  $f_2, \dots$  and  $f_N$ , followed by D/A conversion by a D/A converter 925 and quadrature conversion by a quadrature modulator 930.

Afterward, the multiplexed signal undergoes the frequency conversion by a frequency converter 935, power amplified by a transmission power amplifier 940, and transmitted through an antenna 94. Here, although the conventional parallel transmission method sets the frequency intervals between  $f_1$ ,  $f_2, \dots$  and  $f_N$  such that they are approximately equal to each other or equal to or less than the coherent

bandwidth, the parallel transmission method in accordance with the present invention determines them using the controller 920 such that the frequency intervals between  $f_1$ ,  $f_2$ , ... and  $f_N$  are equal to or greater than the coherent bandwidth.

Figure 10 shows a configuration of a receiver applied to the parallel transmission method in accordance with the present invention.

In Figure 10, as for radio signals received by antennas 1000 and 1005, level detectors 1110 and 1115 detect the received levels of the outputs of amplifiers 1020 and 1025, and a controller 1100 switches to one of the antennas 1000 and 1005 whose output level is greater, followed by conversion to frequencies  $f_1$  and  $f_2$  by frequency converters 1030 and 1035 using a controller 1040. Subsequently, the received signals, passing through bandpass filters (BPFs) 1050 and 1055 and automatic gain controllers (AGCs) 1060 and 1065, are detected by detectors 1070 and 1075, A/D converted by converters 1080 and 1085, aligned their phases by a RAKE combiner 1090, and supplied to a decision section 1095 for making code decision.

[EMBODIMENT 1]

Figure 1 shows an embodiment that sets the frequency intervals at a value equal to or greater

than the coherent bandwidth, in which the vertical axis represents a spectrum axis 100 and the horizontal axis represents a frequency axis 110. In Figure 1, the parallel transmission method will be described which includes three transmitters and receivers as described above, and transmits three different pieces of information between radio stations 130 and 140 using three carriers.

In Figure 1, frequency intervals 120 and 125 between spectra 111, 112 and 113 of the three carriers are set (115) at a value equal to or greater than the coherent bandwidth. This setting 115 causes the spectra 111, 112 and 113 of the three carriers to receive fading independently of each other. Accordingly, even if the spectrum 112 of the second carrier receives the fading during a call and the degradation in transmission quality occurs, the call can be continued using the remaining spectrum 111 of the first carrier and spectrum 113 of the third carrier. In other words, as shown in Figure 10, the receiving side carries out the coherent detection of the spectrum 111 of the first carrier and the spectrum 113 of the third carrier, followed by the maximal ratio combining after the detection by the detectors 1070 and 1075. In this case, since the individual carriers can be considered as nearly

independent, the diversity reception of the two branch maximal ratio combining can be achieved.

[EMBODIMENT 2]

Figure 2 shows an embodiment that sets the frequency intervals at a value close to the coherent bandwidth, in which the vertical axis represents a spectrum axis 100 and the horizontal axis represents a frequency axis 110. In Figure 2, the parallel transmission method will be described which transmits three different pieces of information between the radio stations 130 and 140 using three carriers.

Frequency intervals 220 and 225 between spectra 211, 212 and 213 of the three carriers in Figure 2 are set (215) at a value close to the coherent bandwidth. This setting 215 causes the spectra 211, 212 and 213 of the three carriers to receive fading independently of each other. Accordingly, even if the spectrum 212 of the second carrier receives the fading during a call and the degradation in the transmission quality occurs, the call can be continued using the remaining spectrum 211 of the first carrier and spectrum 213 of the third carrier. In other words, as shown in Figure 10, the receiving side carries out the coherent detection of the spectrum 211 of the first carrier and the spectrum

213 of the third carrier, followed by the maximal  
ratio combining after the detection by the detectors  
1070 and 1075. In this case, since the individual  
carriers can be considered as nearly independent,  
5 the diversity reception of the two branch maximal  
ratio combining can be achieved.

[EMBODIMENT 3]

Figure 3 shows an embodiment that employs a  
plurality of modulation methods, in which the  
10 vertical axis represents a spectrum axis 100 and the  
horizontal axis represents a frequency axis 110. In  
Figure 3, the parallel transmission method will be  
described which transmits three different pieces of  
information between the radio stations 130 and 140  
15 using three carriers.

In Figure 3, the modulation methods of spectra  
311, 312 and 313 of three carriers are QPSK, 16 QAM  
and FSK, respectively. The frequency intervals 320  
and 325 between the spectra 311, 312 and 313 of the  
20 three carriers are set (315) at a value greater than  
the coherent bandwidth. This setting 315 causes the  
spectra 311, 312 and 313 of the three carriers to  
receive fading nearly independently of each other.  
Accordingly, even if the spectrum 313 of the third  
25 carrier receives the fading during a call and the  
degradation in the transmission quality occurs, the

call can be continued using the remaining spectrum 311 of the first carrier and spectrum 312 of the second carrier. The information to be transmitted by the spectrum 313 of the third carrier can be  
5 assigned to the spectrum 312 of the second carrier. The spectrum 312 of the second carrier employs the 16 QAM. Thus, the parallel transmission method in accordance with the present invention can maintain the intended data transmission capacity without  
10 increasing the bandwidth, even if it suffers from the effect of fading.

[EMBODIMENT 4]

Figure 4 shows an embodiment that employs a plurality of modulation methods, in which the  
15 vertical axis represents a spectrum axis 100 and the horizontal axis represents a frequency axis 110. In Figure 4, the parallel transmission method will be described which transmits three different pieces of information between the radio stations 130 and 140  
20 using three carriers.

In Figure 4, the modulation methods of spectra 411, 412 and 413 of the three carriers use QPSK, 16 QAM and 16 QAM, respectively. The frequency intervals 420 and 425 between the spectra 411, 412  
25 and 413 of the three carriers are set (415) close to the coherent bandwidth. This setting 415 causes the

spectra 411, 412 and 413 of the three carriers to receive fading nearly independently of each other. Accordingly, even if the spectrum 413 of the third carrier receives the fading during a call and the degradation in the transmission quality occurs, the call can be continued using the remaining spectrum 411 of the first carrier and spectrum 412 of the second carrier. The information to be transmitted by the spectrum 413 of the third carrier is assigned to the spectrum 412 of the second carrier. The spectrum 412 of the second carrier employs the 16 QAM. In this way, the parallel transmission method in accordance with the present invention can maintain the intended data transmission capacity without increasing the bandwidth, even if it suffers from the effect of fading. Thus, the number of carriers (three, here) can be different from the number of modulation methods (two, in this case).

Incidentally, the modulation methods such as PSK, QAM and FSK employed in the foregoing embodiments can be combinations thereof, or combinations of multivalued modulation of the modulation methods.

In other words, the carries can use different multivalued modulation in accordance with the design of the radio communication system. For example, it

is possible to construct three carrier radio communications employing either 16 QAM, QPSK and 4 FSK, or 256 QAM, 16 QPSK and 64 QAM.

[EMBODIMENT 5]

5           Figure 5 shows an embodiment that employs carriers whose frequency intervals are standardized by PDC, in which the vertical axis represents a spectrum axis 500 and the horizontal axis represents a frequency axis 510. In Figure 5, the parallel  
10 transmission method in accordance with the present invention will be described which transmits four pieces of information between a radio station 530 and a radio station 540 using spectra 511, 512, 513 and 514 of four different carriers.

15           In Figure 5, the spectra 511, 512, 513 and 514 of the carriers are nearly independent. When employing the spectra 511, 512, 513 and 514 of the carriers, the data transmission capacity of Figure 5 is four times as great as that of PDC. The data  
20 transmission capacity of 44.8 kbps can be obtained when the transmission capacity per spectrum of the carrier is 11.2 kbps. Thus, the parallel transmission method in accordance with the present invention is effective for the high-speed  
25 transmission.

[EMBODIMENT 6]

Figure 6 shows an embodiment in which the parallel transmission method in accordance with the present invention is applied to a broadcast service, in which the vertical axis represents a spectrum axis 600, and the horizontal axis represents a frequency axis 610. In Figure 6, the parallel transmission method between a radio station 630 and a radio station 640 will be described which employs spectra 611, 612, 613 and 614 of four different carriers.

As a downlink channel 650, are assigned not only a message channel 611, but also channels 612, 613 and 614 for providing the broadcast service. When only one message channel 651 is used in an uplink channel 655, the modulation methods of the channels 612, 613 and 614 used in the downlink channel 650 can be a modulation method of a voice channel or any other modulation methods.

Using their own mobile stations, users of the present embodiment can receive the broadcast service through the downlink channel 650 while carrying out voice communications such as exchanging messages by PDC. As the broadcast services, they can receive such services as ITS (Intelligent Transportation System) services represented by car-navigation and the like (for example, congestion information,

weather forecast, or various types of news services). In this way, the uplink and downlink channels 655 and 650 can establish different channel capacity and reliability.

5 [EMBODIMENT 7]

Figure 7 shows an embodiment in which the voice transmission and data transmission are mixed, wherein the vertical axis represents a spectrum axis 700, and the horizontal axis represents a frequency axis 710. In Figure 7, the parallel transmission method between a radio station 730 and a radio station 740 will be described which employs spectra 711, 712 and 713 of three different carriers.

In a downlink channel 750, the modulation methods of channels 711, 712 and 713 are QPSK, 16 QAM and FSK, respectively. In an uplink channel 755, the modulation methods of channels 751, 752 and 753 are 16 QAM, QPSK and FSK, respectively. As long as their bandwidths are the same, the modulation methods of the spectra 711, 712 and 713 of the carriers are not limited in the present embodiment. Applying PDC to voice enables the data transmission using the 16 QAM. Thus, the parallel transmission method in accordance with the present invention can flexibly achieve the services with different transmission quality such as the voice transmission

and data transmission by using the same transmission method.

## WE CLAIM:

1. A parallel transmission method comprising the steps of:
  - establishing each of frequency intervals between M different carriers at a value equal to or greater than a coherent bandwidth or at a value approximately equal to the coherent bandwidth, where M is an integer greater than one;
  - modulating M different signals by at most M different modulation methods;
  - simultaneously transmitting the M different signals which have been modulated by the at most M different modulation methods, by using the M different carriers, respectively;
  - receiving the M different signals; and
  - combining the M different signals into one signal.
2. The parallel transmission method as claimed in claim 1, wherein the at most M different modulation methods are a combination including at least one of PSK, QAM and FSK.
3. The parallel transmission method as claimed in claim 2, wherein the combination including at least one of the PSK, QAM and FSK modulation methods includes a combination of multivalued modulation of each of the modulation methods.
4. A reception method comprising the steps of:
  - receiving M different signals which have been modulated by at most M different modulation methods and simultaneously transmitted by using M different carriers, respectively, each of frequency intervals between the M different carriers having been established at a value equal to or greater than a coherent bandwidth or at a value approximately equal to the coherent bandwidth, where M is an integer greater than one;
  - and

combining the M different signals into one signal.

5. The reception method as claimed in claim 4, wherein the at most M different modulation methods are a combination including at least one of PSK, QAM and FSK.

6. The reception method as claimed in claim 5, wherein the combination including at least one of the PSK, QAM and FSK modulation methods includes a combination of multivalued modulation of each of the modulation methods.

7. A parallel transmission system comprising a transmitter and a receiver, wherein the transmitter comprises:

means for establishing each of frequency intervals between M different carriers at a value equal to or greater than a coherent bandwidth or at a value approximately equal to the coherent bandwidth, where M is an integer greater than one;

means for modulating M different signals by at most M different modulation methods;

means for simultaneously transmitting the M different signals which have been modulated by the at most M different modulation methods, by using the M different carriers, respectively, and the receiver comprises:

means for receiving the M different signals; and

means for combining the M different signals into one signal.

8. The parallel transmission system as claimed in claim 7, wherein the at most M different modulation methods are a combination including at least one of PSK, QAM and FSK.

9. The parallel transmission system as claimed in claim 8, wherein the combination including at least one of the PSK, QAM and FSK modulation methods includes a combination of multivalued modulation of each of the modulation methods.

10. A receiver comprising:

5 means for receiving M different signals which have been modulated by at most M different modulation methods and simultaneously transmitted by using M different carriers, respectively, each of frequency intervals between the M different carriers having been established at a value equal to or greater than a coherent bandwidth or at a value approximately equal to the coherent bandwidth, where M is an integer greater than one;

10 and

means for combining the M different signals into one signal.

11. The receiver as claimed in claim 10, wherein the at most M different modulation methods are a combination including at least one of PSK, QAM and FSK.

12. The receiver as claimed in claim 11, wherein the combination including at least  
15 one of the PSK, QAM and FSK modulation methods includes a combination of multivalued modulation of each of the modulation methods.

13. A transmission method comprising the steps of:

20 establishing each of frequency intervals between M different carriers at a value equal to or greater than a coherent bandwidth or at a value approximately equal to the coherent bandwidth, where M is an integer greater than one;

modulating M different signals by at most M different modulation methods; and

simultaneously transmitting the M different signals which have been modulated by the at most M different modulation methods, by using the M different carriers, respectively.

14. The transmission method as claimed in claim 13, wherein the at most M different modulation methods are a combination including at least one of PSK, QAM and FSK.

15. The transmission method as claimed in claim 14, wherein the combination including at least one of the the PSK, QAM and FSK modulation methods includes a  
5 combination of multivalued modulation of each of the modulation methods.

16. A transmitter comprising:

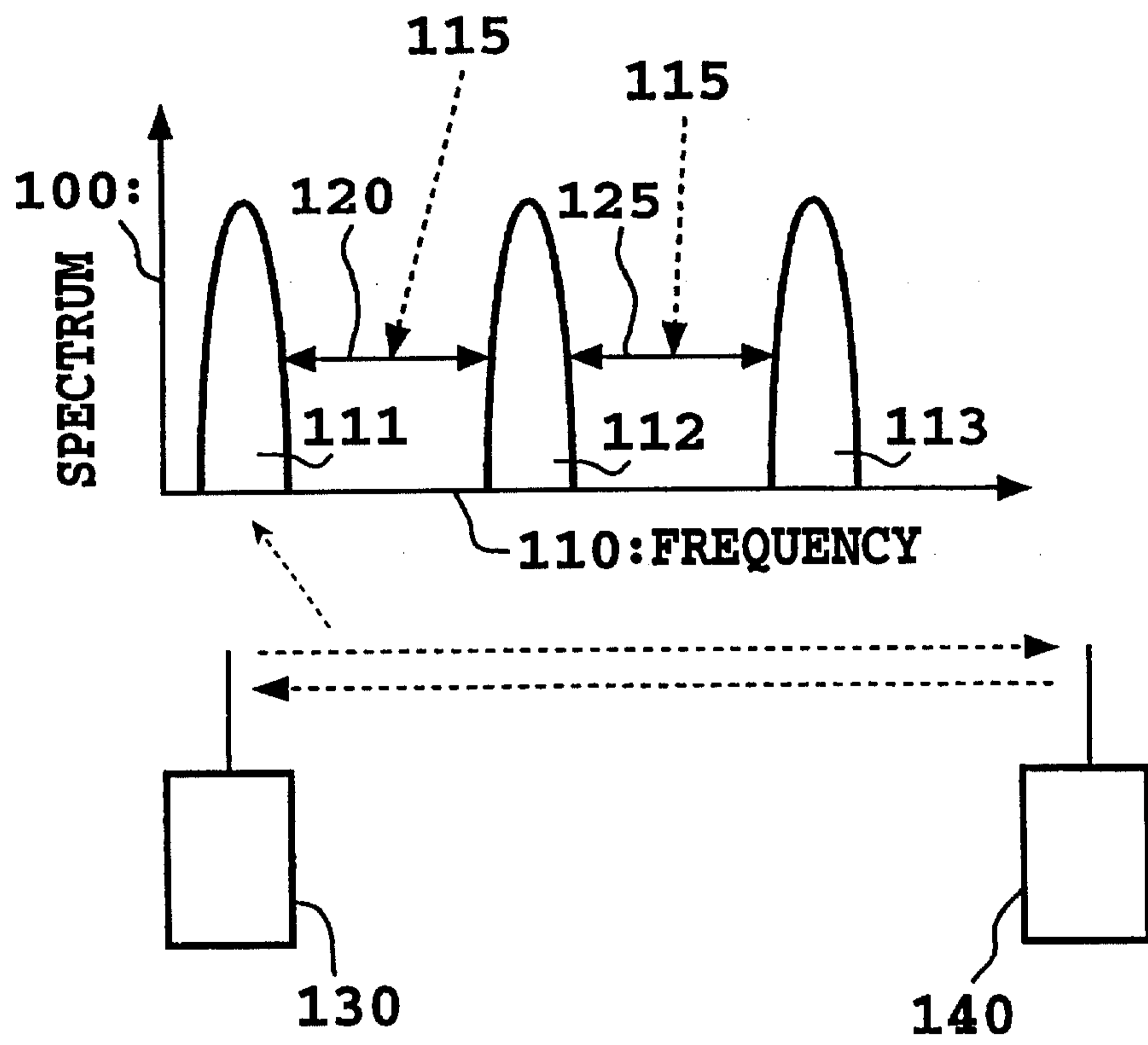
means for establishing each of frequency intervals between M different carriers at a value equal to or greater than a coherent bandwidth or at a value approximately equal to the coherent bandwidth, where M is an integer greater than one;

10 means for modulating M different signals by at most M different modulation methods; and

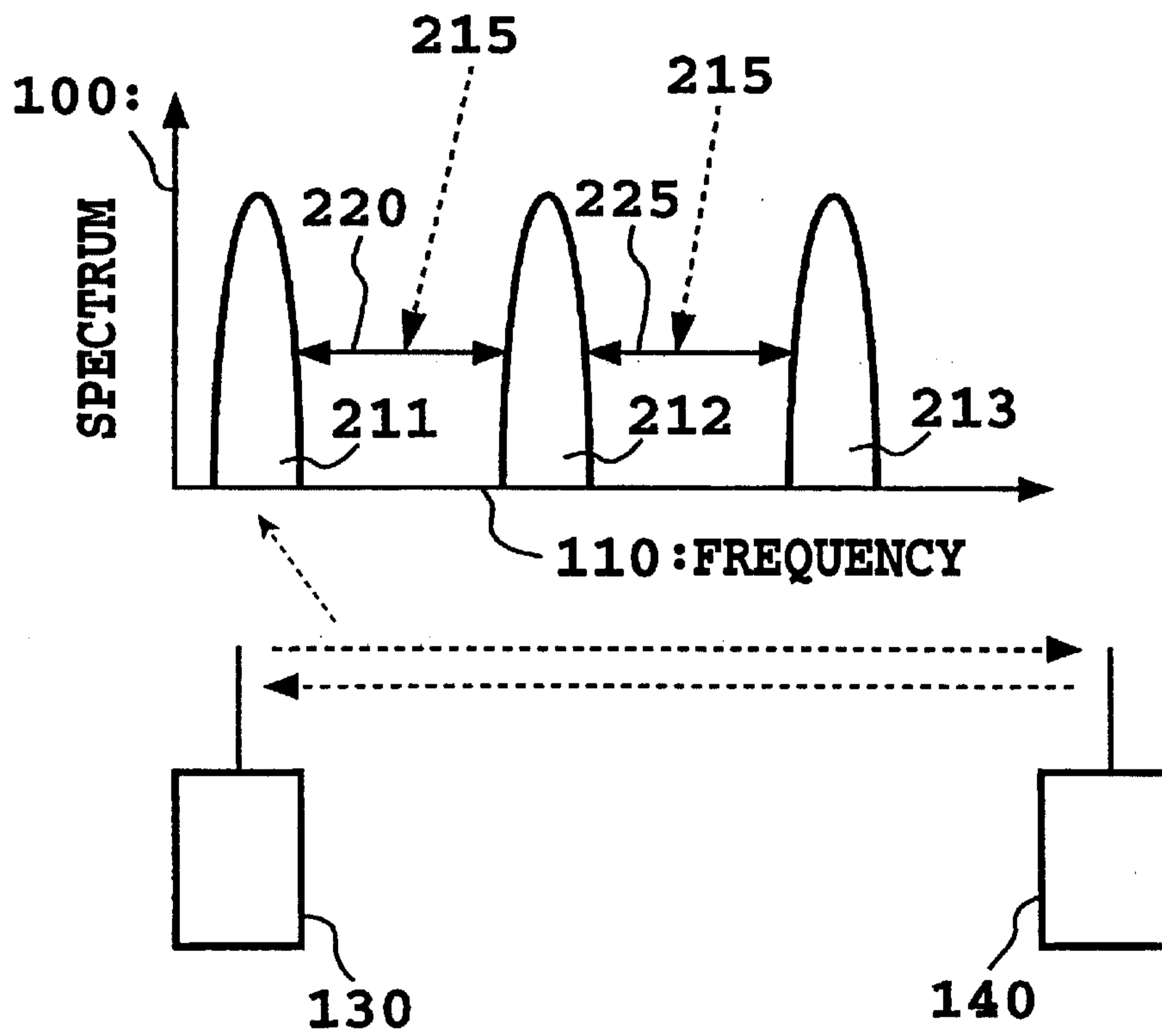
means for simultaneously transmitting the M different signals which have been modulated by the at most M different modulation methods, by using the M different carriers, respectively.

15 17. The transmitter as claimed in claim 16, wherein the at most M different modulation methods are a combination including at least one of PSK, QAM and FSK.

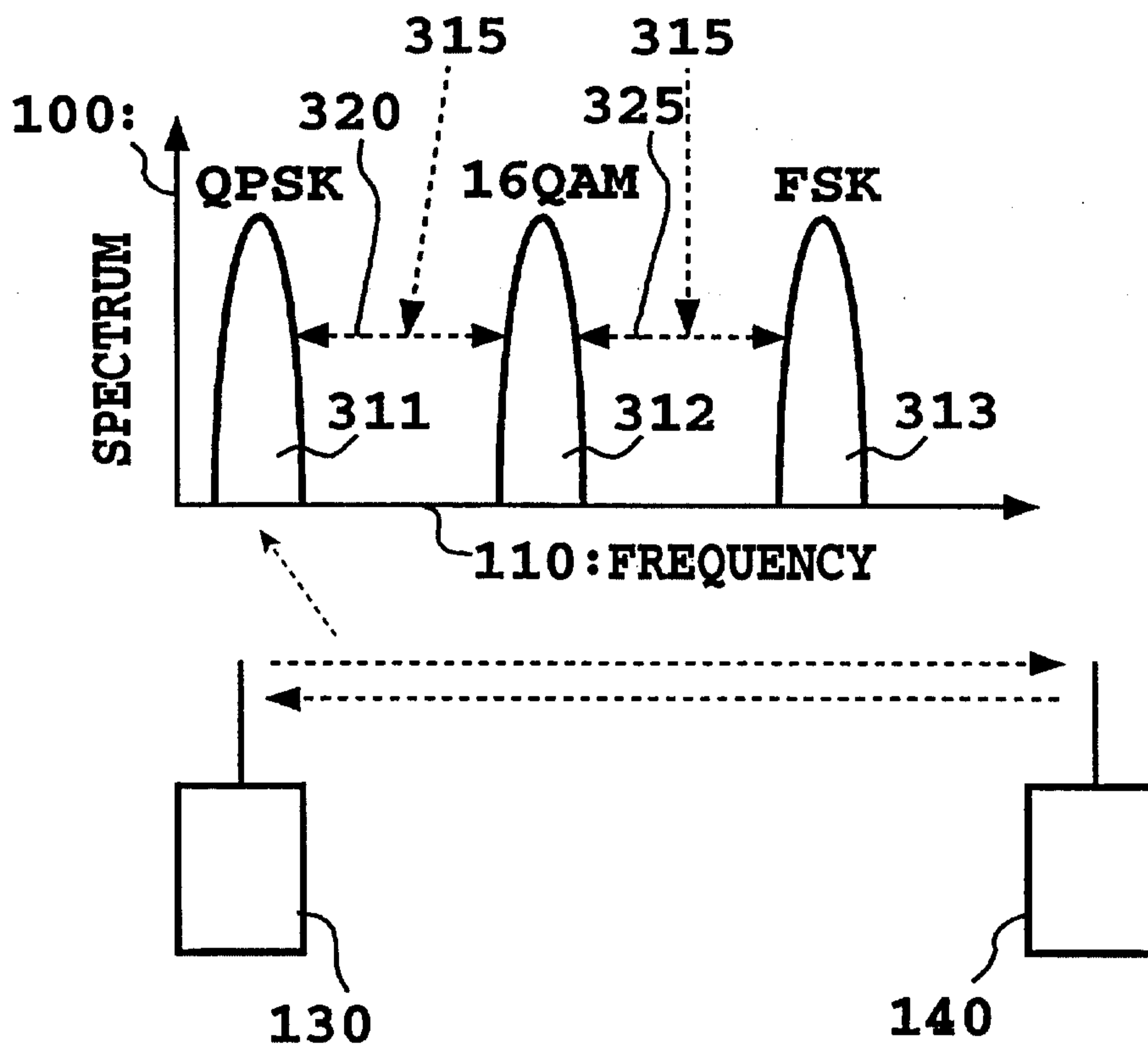
18. The transmitter as claimed in claim 17, wherein the combination including at least one of the PSK, QAM and FSK modulation methods includes a combination of multivalued modulation of each of the modulation methods.



**FIG.1**

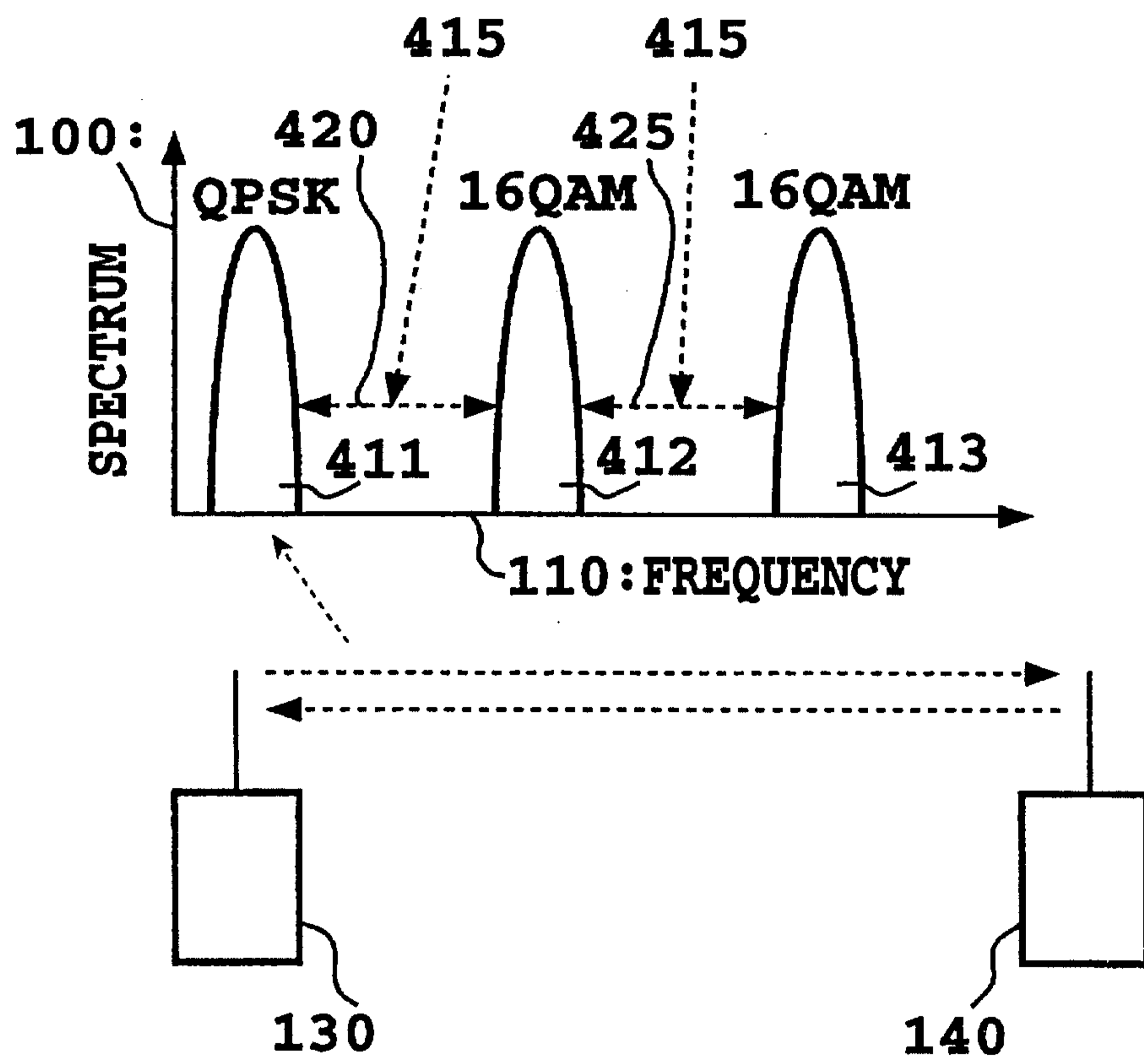


**FIG.2**



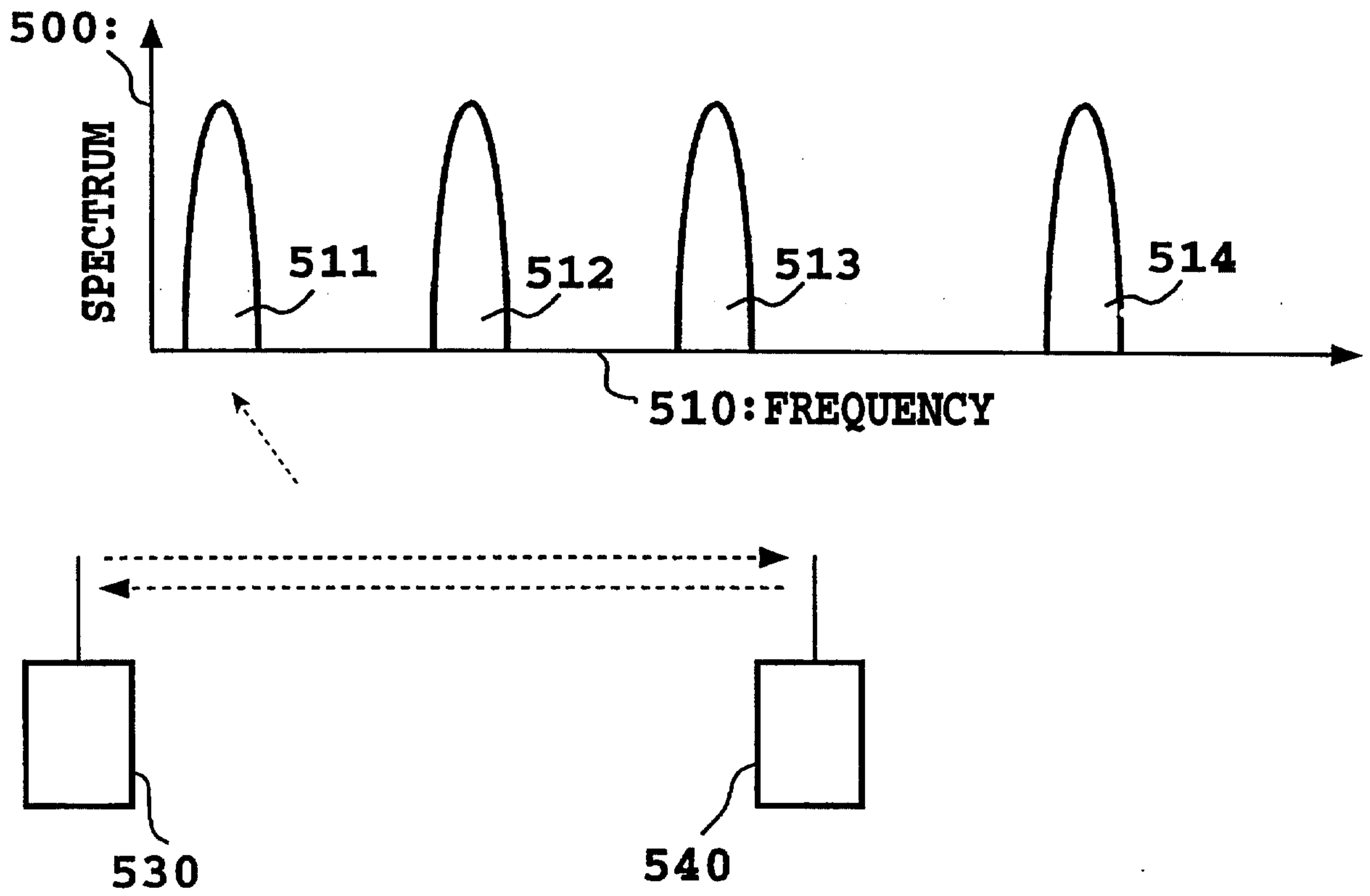
**FIG.3**

4/10



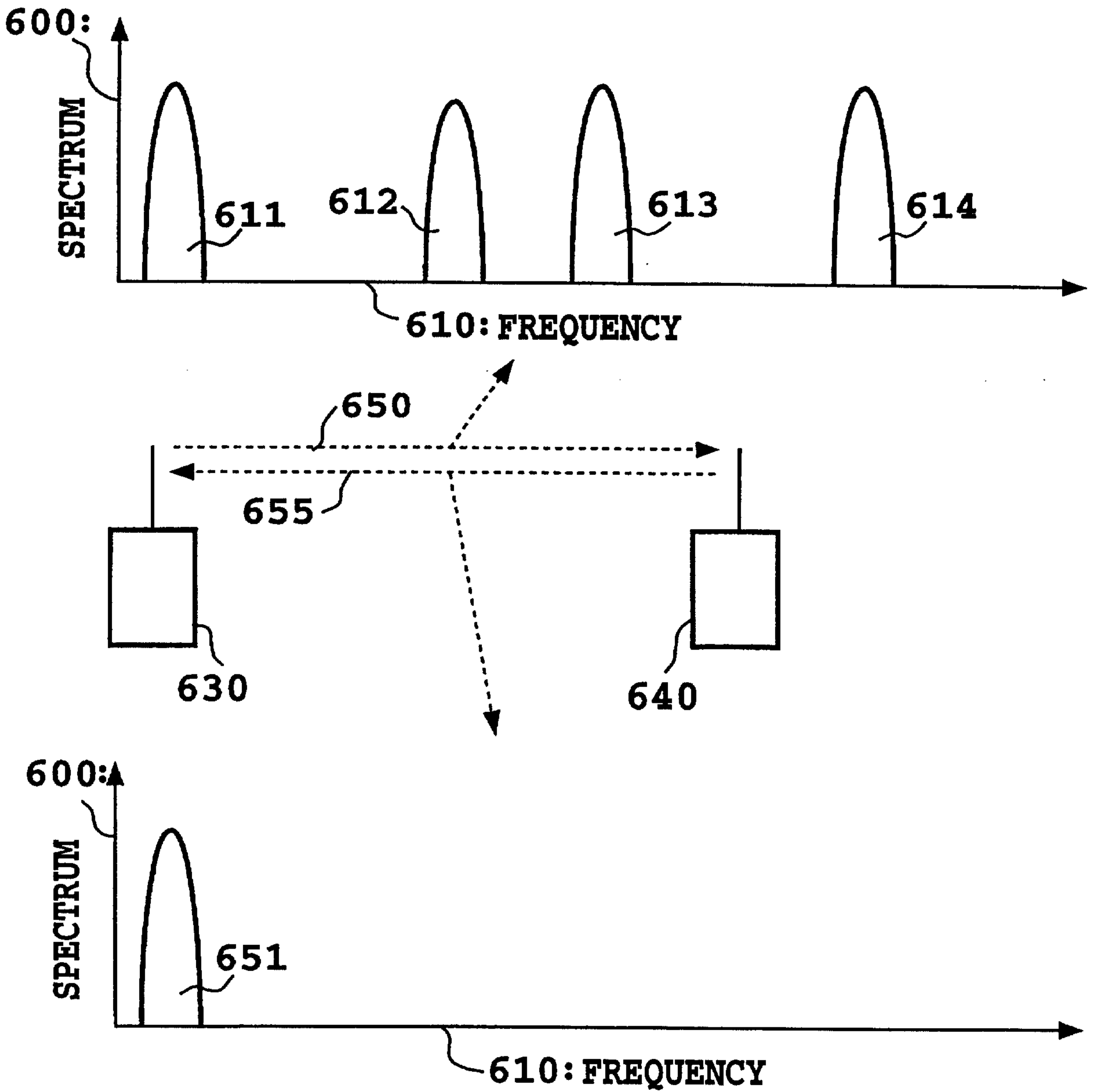
**FIG.4**

5/10



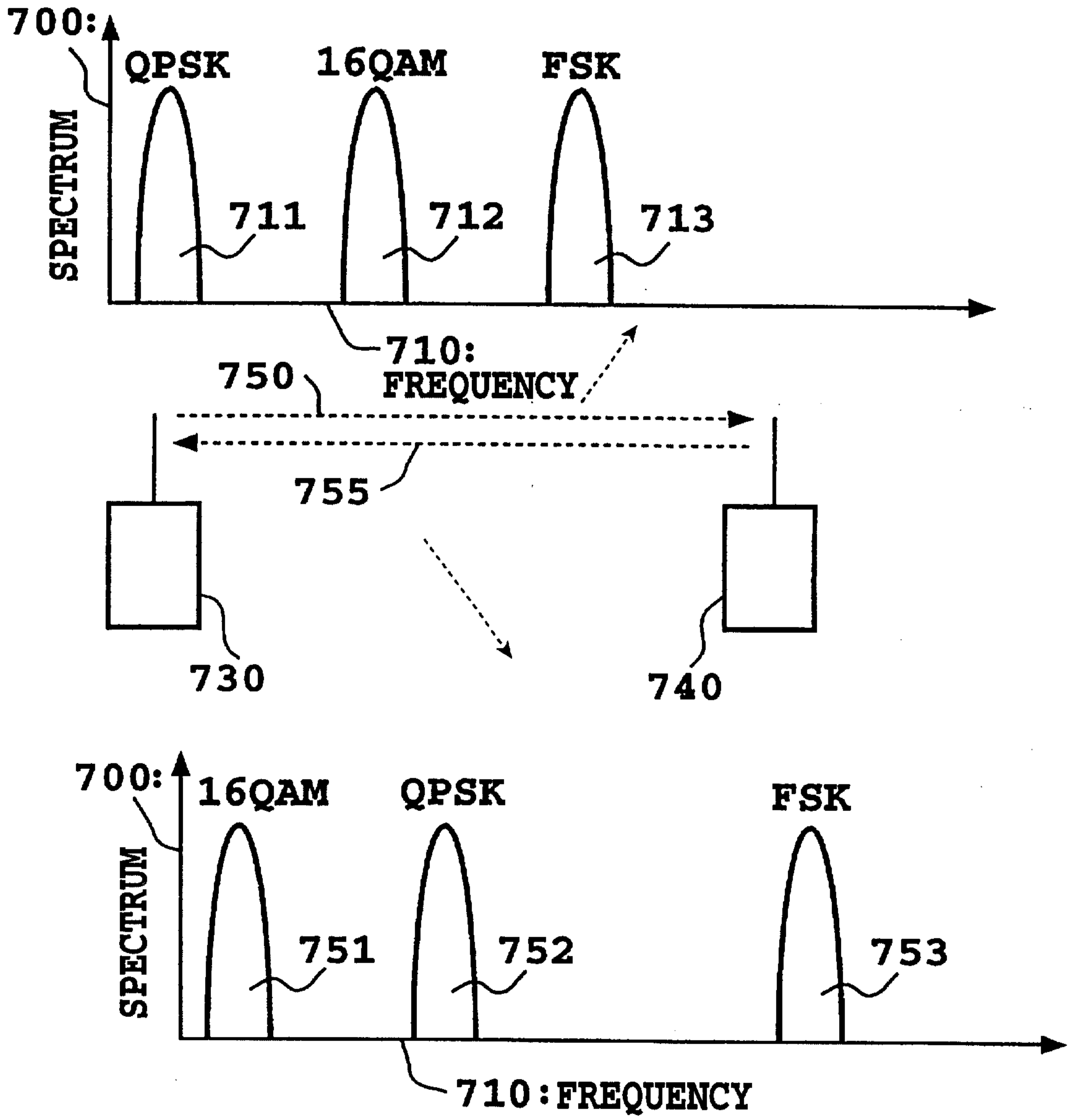
**FIG.5**

6/10



**FIG.6**

7/10



**FIG. 7**

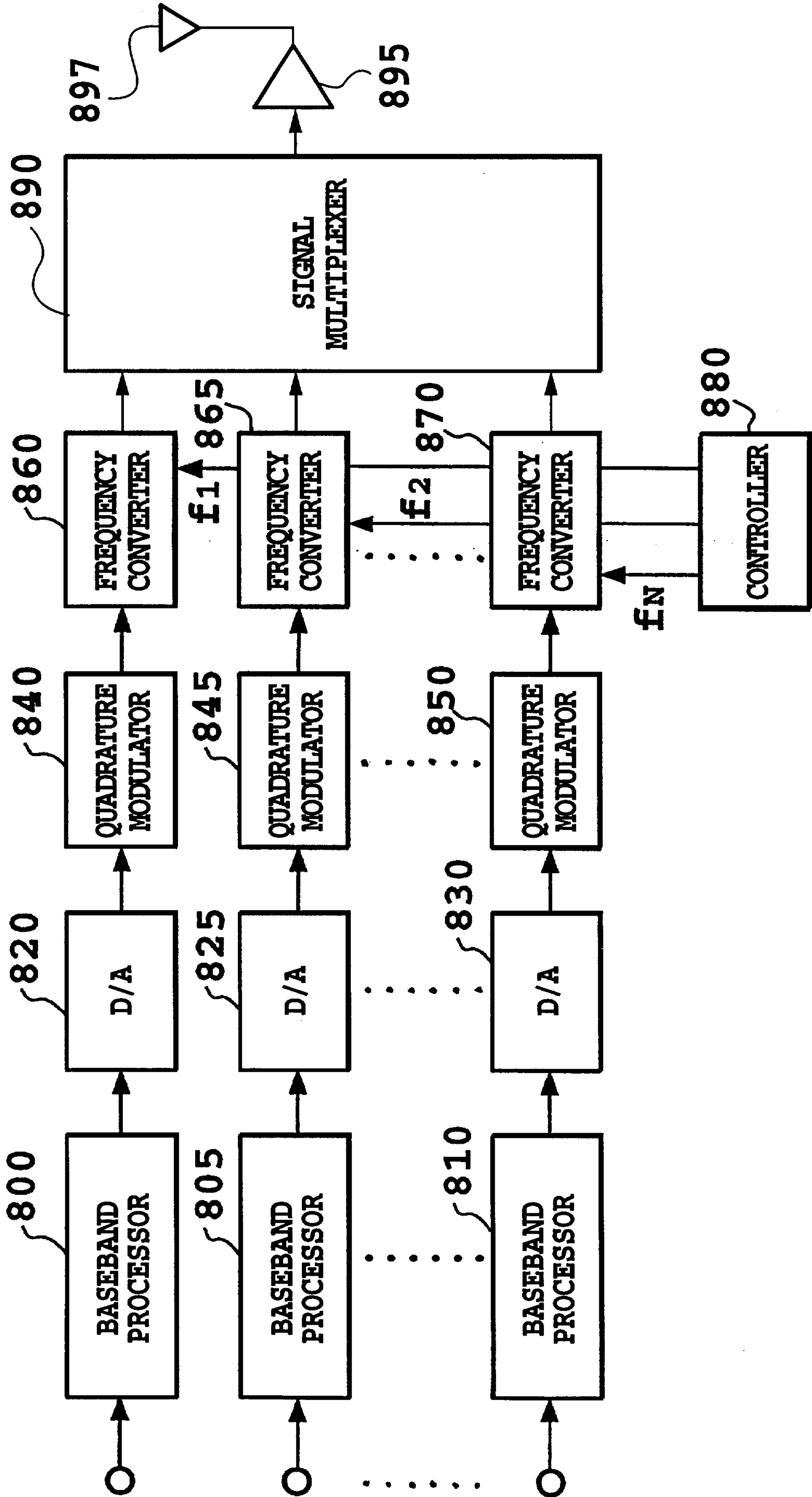
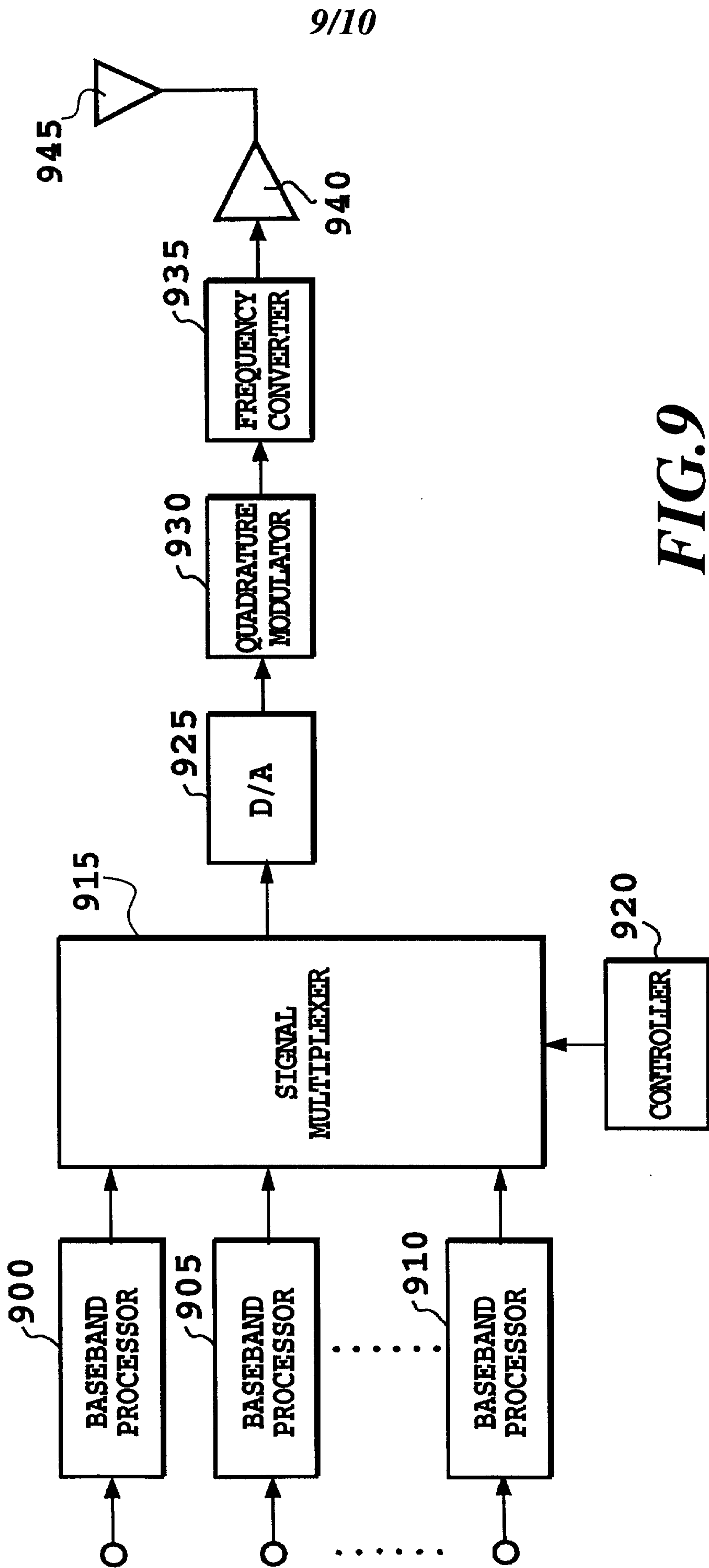


FIG. 8



9/10

FIG. 9

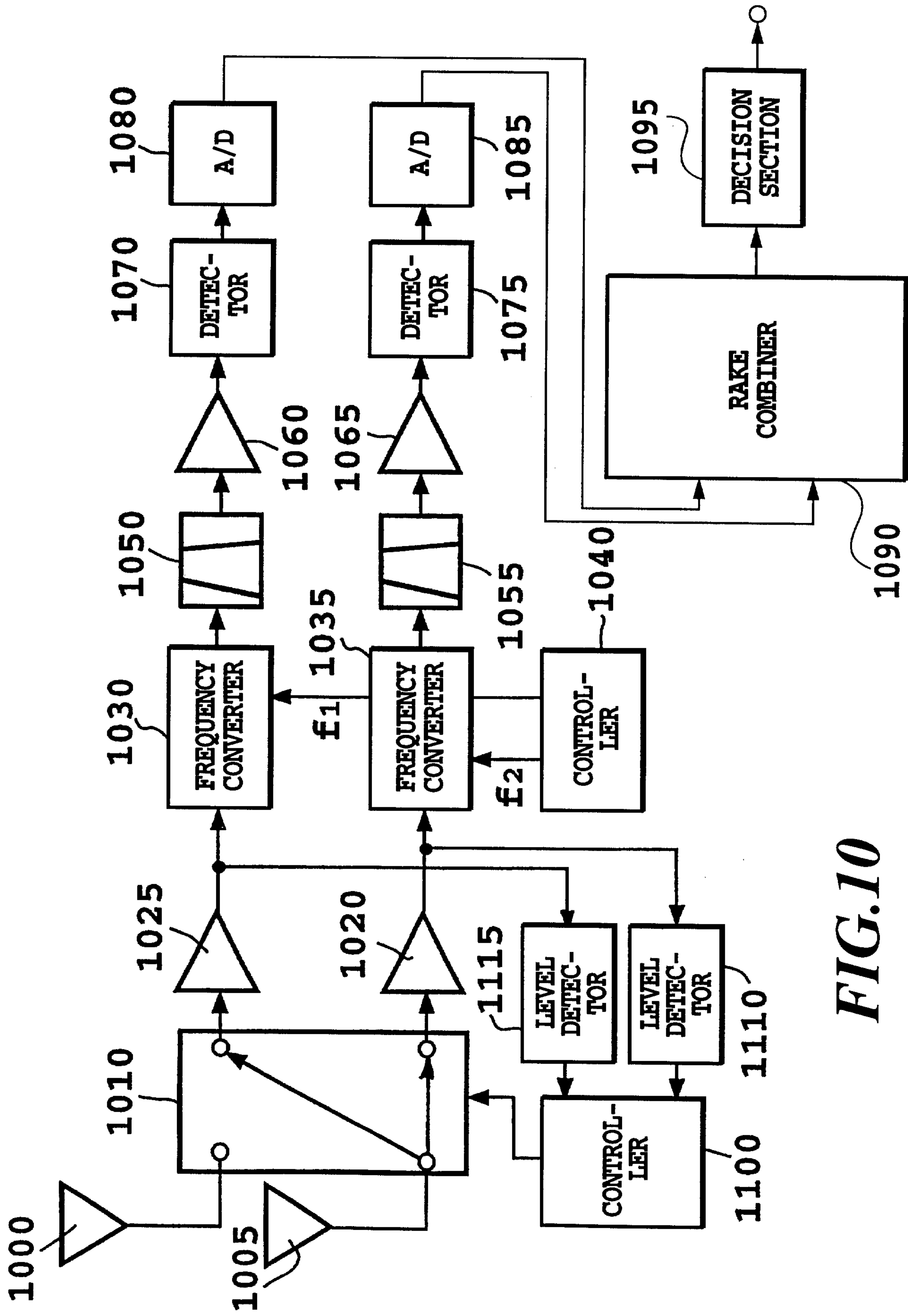


FIG. 10

