

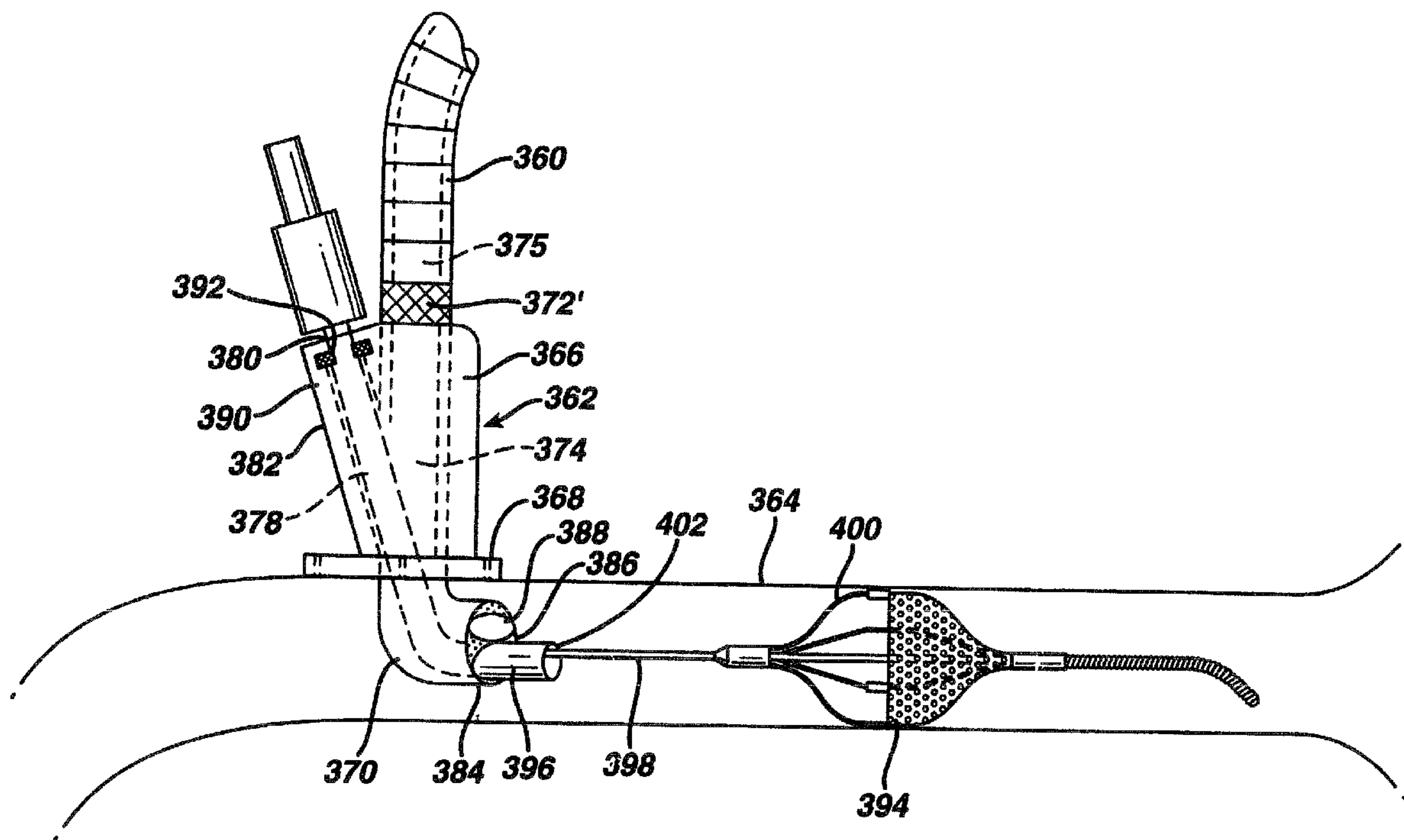

(22) Date de dépôt/Filing Date: 2003/02/25
(41) Mise à la disp. pub./Open to Public Insp.: 2003/08/26
(30) Priorité/Priority: 2002/02/26 (10/083,868) US

(51) Cl.Int.⁷/Int.Cl.⁷ A61F 2/01, A61M 25/00, A61M 1/00
(71) Demandeur/Applicant:
CORDIS CORPORATION, US
(72) Inventeurs/Inventors:
SUTTON, GREGG S., US;
WELCH, JEFFREY, US
(74) Agent: SIM & MCBURNEY

(54) Titre : SYSTEME DE FILTRATION VASCULAIRE POUR LA DERIVATION CARDIOPULMONAIRE
(54) Title: VASCULAR FILTER SYSTEM FOR CARDIOPULMONARY BYPASS



(57) Abrégé/Abstract:

A removable vascular filter system for capture and retrieval of emboli while allowing continuous perfusion of blood during a cardiopulmonary bypass procedure, comprising a porous filter membrane with variable diameter holes, and a filter membrane support structure. The system may minimize the incidence of stroke, myocardial infarction or other clinical complications that may be associated with cardiopulmonary bypass procedures.

CRD-0991

ABSTRACT OF THE DISCLOSURE

A removable vascular filter system for capture and retrieval of emboli while allowing continuous perfusion of blood during a cardiopulmonary bypass procedure, comprising a porous filter membrane with variable diameter holes, and a filter membrane support structure. The system may minimize the incidence of stroke, myocardial infarction or other clinical complications that may be associated with cardiopulmonary bypass procedures.

CRD-0991

Vascular Filter System for Cardiopulmonary Bypass

5

Cross-Reference to Related Applications

This patent application is a continuation-in-part of pending U.S. Patent
10 Application Serial No. 09/365,144, filed July 30, 1999, which is incorporated
herein by reference.

Background of the Invention

I. Field of the Invention

15

The present invention relates to the treatment of vascular disease by
cardiopulmonary bypass surgery. More particularly, the present invention
relates to a system that reduces macro- and micro-embolization during
cardiopulmonary bypass surgery.

20

II. Discussion of the Related Art

A variety of surgical and non-surgical angioplasty procedures have been
developed for removing obstructions from blood vessels. Balloon angioplasty
utilizes a balloon-tipped catheter which may be inserted within a stenosed
region of the blood vessel. By inflation of the balloon, the stenosed region is
25 dilated. Stenting involves the permanent implantation of a metallic scaffold in
the area of the obstruction, following balloon dilatation. The stent is often
delivered on an angioplasty balloon, and is deployed when the balloon is
inflated. Another alternative is the local delivery of medication via an infusion

CRD-0991

catheter. Other techniques, such as atherectomy, have also been proposed. In atherectomy, a rotating blade is used to shave plaque from an arterial wall. Surgery involves either removing the plaque from the artery or attaching a graft to the artery so as to bypass the obstructing plaque.

5 One problem common to all of these techniques is the potential inadvertent release of portions of the plaque or thrombus, resulting in emboli which can lodge elsewhere in the vascular system. Such emboli may be dangerous to the patient, and may cause severe impairment of the distal circulatory bed. Depending upon the vessel being treated, this may result in a
10 stroke or myocardial infarction or limb ischemia.

Vascular filters or embolism traps for implantation into the vena cava of a patient is well known, being illustrated by, for example, U. S. Patents Nos. 4,727,873 and 4,688,533. Additionally, there is a substantial amount of medical literature describing various designs of vascular filters and reporting
15 the results of the clinical and experimental use thereof. See, for example, the article by Eichelter & Schenk entitled "Prophylaxis of Pulmonary Embolism," Archives of Surgery, Vol. 97, August 1968, pp. 348 et seq. See, also, the article by Greenfield, et al., entitled "A New Intracaval Filter Permitting Continued Flow and Resolution of Emboli", Surgery, Vol. 73, No. 4, pp. 599-
20 606 (1973).

Vascular filters are used, often during a postoperative period, when there is a perceived risk of a patient encountering a pulmonary embolus resulting from clots generated at the surgical site. Typically, the filter is mounted in the vena cava to catch large emboli passing from the surgical site
25 to the lungs.

CRD-0991

The vascular filters of the prior art are usually permanently implanted in the venous system of the patient, so that even after the need for the filter has abated, the filter remains in place for the lifetime of the patient, absent surgical removal. U.S. Patent No. 3,952,747 describes a stainless steel filtering device
5 which is permanently implanted transvenously within the inferior vena cava. The filtering device is intended to treat recurrent pulmonary embolism. U.S. Patent No. 4,873,978 describes a catheter device comprising a catheter body having a strainer mounted at its distal end. The strainer is shiftable between an opened configuration where it extends substantially across the blood vessel
10 to entrap passing emboli, and a closed configuration where it retains the captured emboli during removal of the catheter. A mechanism actuatable at the proximate end of the catheter body allows selective opening and closing of the strainer. Typically, the strainer is a collapsible cone having an apex attached to a wire running from the distal end to the proximate end of the catheter body.

15 Permanent implantation may be deemed medically undesirable, but it has been done because vascular filters are implanted in patients primarily in response to potentially life threatening situations. Accordingly, the potential disadvantages of permanent implantation of a vascular filter are often accepted.

20 Notwithstanding the usefulness of the above-described methods, a need still exists for an apparatus and method for substantially reducing the risk of embolization associated with cardiopulmonary bypass surgery. In particular, it would be desirable to provide a device which could be located within the vascular system to collect and retrieve portions of plaque and thrombus which
25 have dislodged during the surgical procedure.

CRD-0991

SUMMARY OF THE INVENTION

The present invention provides a vascular filter system which may be used to address the clinical problem of preventing embolization associated with cardiopulmonary bypass surgery, which may result in stroke or myocardial infarction, as briefly described above.

An objective of the present invention is to provide a vascular filter system for reducing macro- and micro-embolization. Another objective of the present invention is to provide a vascular filter system which is readily removable from the vascular system, or elsewhere, of a patient when the filter is no longer needed. It is a further objective of the present invention to provide a vascular filter system having a configuration which does not require hooks to penetrate and grip the blood vessel walls, so that the implantation results in less blood vessel injury. It is yet a further objective of the invention to capture thrombus or emboli generated during a cardiopulmonary procedure. It is yet a further objective of the invention to provide a filter membrane with variable-sized holes to allow distal perfusion while capturing embolic particulates.

In one exemplary embodiment, the filter system comprises an apparatus to be inserted into a patient's aorta, comprising one lumen in fluid communication with a housing and another lumen which facilitates advancing a vascular filter to be positioned downstream in the aorta from the apparatus to capture any thrombus or emboli introduced during the procedure. More particularly, the filter system may comprise a housing having distal and proximal ends, where the proximal end comprises a connector for connecting to housing. The distal end has a distal member having at least one opening.

CRD-0991

The housing preferably comprises two lumens, the first of which is in fluid communication with the housing, and the second of which is in fluid communication with a port. The lumens each extend to respective openings in the distal end of the housing. Preferably, the distal end of the housing
5 comprises a distal member with openings that extend at an angle, preferably about ninety degrees, for insertion into a blood vessel such as an artery, specifically the aorta.

An advantage of the present invention is that it provides the benefits of filtration and capture of embolic particulates, temporarily, during a surgical
10 procedure. Another advantage of the present invention is that it provides a filter membrane with variable-sized holes to allow distal perfusion while capturing embolic particulates.

Given the following enabling description of the drawings, the apparatus should become evident to a person of ordinary skill in the art.

15

BRIEF DESCRIPTION OF THE DRAWINGS

The present invention will be apparent upon consideration of the following detailed description, taken in conjunction with the accompanying drawings, in which the reference characters refer to like parts throughout, and
20 in which:

Fig. 1 illustrates a lateral, partial cross-sectional view of one exemplary embodiment of the present invention with the filter membrane in an open position.

Fig. 2 illustrates a lateral, partial cross-sectional view of the exemplary
25 embodiment of the present invention illustrated in Fig. 1 with the sheath closed.

CRD-0991

Fig. 3 illustrates a schematic representation of a portion of a filter membrane in accordance with the present invention.

Fig. 4 illustrates a lateral view of a core wire in accordance with the present invention.

5 Fig. 5 illustrates a cross-sectional view across section line 5-5 of a portion of the core wire illustrated in Fig. 4.

Fig. 6 illustrates a lateral, cross-sectional view of an alternate basket structure for the exemplary embodiment illustrated in Fig. 1.

10 Fig 7 illustrates a lateral, partial cross-sectional view of another exemplary embodiment of the present invention.

Fig. 8 illustrates a lateral, partial cross-sectional view of another exemplary embodiment of the present invention.

15 Fig. 9 illustrates a schematic, partial cross-sectional view of another exemplary embodiment of the present invention where the distal section of the filter basket is inverted.

Fig, 10 illustrates a schematic, partial cross-sectional view of the exemplary embodiment shown in Fig. 9 where the filter basket is collapsed.

20 Fig. 11 illustrates a schematic representation of an exemplary embodiment of the invention wherein a filter system according to the invention is positioned in a patient's aorta; and

Fig. 12 illustrates a schematic representation of another exemplary embodiment of the invention.

CRD-0991

DETAILED DESCRIPTION OF THE PREFERRED EMBODIMENTS

The present invention relates to a vascular filter system for use in cardiopulmonary bypass, which may substantially reduce the risk of distal embolization during surgical procedures, while still allowing perfusion of distal tissue.

The system comprises a thin, porous filter membrane with variable-sized openings which is capable of blocking emboli and which is attached to the distal end of a guidewire. In one exemplary embodiment of the invention, a thin, flexible, perforated membrane is supported by four or more supports that form a distally extending basket. At least one end of the basket is attached to the guidewire, and the other, slidable end may be moved to cause the membrane to open or close.

The present invention may be better appreciated by reference to the drawings. Fig. 1 illustrates a lateral, cross-sectional view of a distal end of a guidewire 160 with a filter membrane 170 attached thereto. Fig. 1 shows guidewire 160 with a shapeable soft "floppy" tip 162 at its extreme distal end which provides flexibility and maneuverability to the guidewire 160. The filter membrane in Fig. 1 is illustrated in an open position.

Guidewire 160 comprises a core wire 164, which extends into floppy tip 162, and a sheath 166. The filter membrane 170 is supported by a basket 169 comprising two or more filter basket wires 168, having distal ends 172 and proximal ends 174. The distal ends 172 of basket wires 168 are fixedly attached by distal radiopaque marker or crimp band 176, or other suitable means, to core wire 164, and the proximal ends 174 of basket wires 168 are

CRD-0991

attached to proximal radiopaque marker or crimp band 178, which is slidable over core wire 164, optionally with a polymeric, such as polyimide, or metallic sleeve between core wire 164 and proximal ends 174. Preferably, proximal marker 178 is fixedly attached to core wire 164, and distal marker 176, with a
5 polymeric or metallic sleeve, is slidable over core wire 164.

The flow of blood in Fig. 1 is toward the distal end of guidewire 160. As such, the force of the flow of blood pushes on deployed filter membrane 170 and helps to maintain filter membrane 170 in the deployed position.

A sheath member 180 is attached to the distal end of sheath 166,
10 sheath member 180 having a lumen 182 with a diameter and length sufficient to receive or slide over proximal marker 178. Sheath 166 and sheath member 180 may be either separate pieces bonded together or a continuous, integral structure. Sheath 166 and sheath member 180 are each made from low friction polymeric material, preferably polytetrafluoroethylene, polyethylene,
15 nylon, or polyurethane.

Filter membrane 170 may comprise a number of different metallic and non-metallic permeable membranes having sufficient porosity to facilitate blood flow but having sufficiently small openings to capture emboli. Filter membrane 170 is preferably affixed at least at its distal portion 184 to core wire 164 and/or
20 basket wire distal ends 172 and, optionally, to basket wires 168. The remainder of filter membrane 170 may be unattached or, preferably, attached to basket wires 168, such as by a suitable adhesive. Preferably basket wires 168 are encapsulated in membrane 170.

Basket 169 may be somewhat cylindrical in its middle with tapered,
25 conical, proximal and distal portions. Alternately, basket 169 may be slightly

CRD-0991

spherical, optionally with a flat, cylindrical middle portion. Preferably basket 169 is from about five to about forty millimeters in length and from about two to about thirty millimeters, or from about two to about twenty millimeters, in diameter at its widest.

5 The proximal end of the sheath 180 is attached to a control handle or guidewire torquer 186. Control handle 186 has an opening 188 for core wire 164 so that sheath 180 can move slidably over core wire 164. For example, when sheath 180 is moved distally toward basket wires 168, filter membrane 170 collapses. Also, there may be instances where sheath 180 will be
10 removed proximally so that other catheters or cardiovascular appliances may be introduced over the core wire 164. Control handle 186, which functions as a torque device, also primarily functions to lock sheath 180 to core wire 164 during insertion.

 There are a number of known, commercially available guidewire
15 torquers that may be modified to function as control handle 186. Modification includes, but is not limited to, providing a slightly larger central lumen.

 In Fig. 2 sheath 166 and sheath member 180 are shown advanced distally so that basket wires 168 and filter member 170 are collapsed against core wire 164. The distal end 192 of sheath member 180 may optionally be
20 slightly tapered to provide a better profile for insertion.

 In an exemplary embodiment of the present invention, as shown in Fig. 3, filter membrane 170 comprises a polymeric material such as polyurethane or silicone elastomer that has openings or holes 190 that vary in diameter with one another. Alternately, the filter membrane may comprise fabric or non-
25 fabric meshes, such as those used in known hemodialysis filters or heart-lung

CRD-0991

bypass machine filters. Suitable materials include polymers or physiologically acceptable metals or alloys. The openings or holes 190 may be created in the material through a laser drilling or other suitable process, or they may be naturally-occurring openings or holes in the material itself.

5 Holes 190 of filter membrane 170, a pattern for which is seen in Fig. 3, are preferably only on the conical portion of filter membrane 170. The holes 190 may be from about twenty to about three hundred microns in diameter, and may vary in diameter as compared with one another. The holes 190 may also comprise fibers attached to the circumference of the holes 190, which can
10 serve to increase embolic capture. The vertical row separation of holes 190 may be from about 1.2 to 1.4 times the hole diameter and the center-to-center diameter of holes 190 may be from about 1.4 to 1.6 times the hole diameter, or in an exemplary embodiment the vertical and horizontal spacing of the holes is such that the center-to-center spacing of the holes is from about 1.2 to 2.0
15 times the hole diameter. Preferably the open area of the holes 190 represents from about ten to fifty percent, more preferably from about ten to forty percent of the filter surface. Alternatively, the holes may be non-uniformly spaced. The mesh should have holes of a size sufficient to block and capture any micro- and macro-emboli which may flow downstream from the site where the
20 stenosis or other problem is being treated, but large enough such that blood flow is not substantially impeded. The mesh used in the filter device of the present invention may have a hole size of from about twenty to about three hundred microns, preferably from about fifty to about one hundred fifty microns. Moreover, the size of filter membrane 170 is such as to allow a firm fit between
25 filter membrane 170 and an artery wall. The diameter of filter membrane 170

CRD-0991

will be directly related to the artery being treated, with typical diameters ranging from about two millimeters to about forty millimeters, most preferably from about two millimeters to about twenty millimeters.

Referring back to Figs. 1 and 2, basket wires 168 may comprise a suitable, physiologically acceptable metal. Stainless steel or nitinol are preferred, although titanium or other metal alloys could be used.

Core wire 164, illustrated in greater detail in Fig. 4, where the proximal and middle portions 200 and 202 are substantially uniform in diameter, and then the distal portion 204 tapers to an end point 206. In fact, distal portion 204 could taper uniformly or, more preferably, non-uniformly, as shown in Fig. 4. Typically core wire 164 is from about two hundred fifty to three hundred centimeters in length, with an initial diameter of from about 0.009 to 0.038 inches, preferably from about 0.014 to 0.018 inches. Distal section 204 is typically from about eight to ten centimeters. With a diameter that tapers to from about 0.001 to about 0.005 inches, Core wire 164 may optionally have a thin polymeric coating 207 for friction reduction. Preferably end point 206 is a solid, squat cylinder, as shown in Figs. 4 and 5.

Referring back to Fig. 1, floppy tip 162 preferably comprises a radiopaque helical spring 210 that is fixedly attached, e.g., by welding, brazing, or soldering, to end point 206 and, optionally, attachment point 208. Optionally spring coil 210 may have a polymeric or lubricious coating 212.

Fig. 6 represents an alternate design of the filter system of the present invention, where basket wires 220 are formed into a substantially helical shape or configuration. Filter member 222 covers or encompasses the distal portion of basket wires 220, and the proximal and distal portions of basket wires 220

CRD-0991

are secured by proximal radiopaque marker or crimp band 224 and distal radiopaque marker or crimp band 226, respectively. Markers 224 and 226 are fixed or slidable on core wire 228 as described above. Preferably there are from four to eight basket wires 220, each with a rotation of from about forty-five
5 degrees to three hundred sixty degrees.

Additional exemplary embodiments of the present invention are illustrated in Figs. 7 and 8. The schematic representation in Fig. 7 depicts a filter membrane 280 supported by strut wires 282. The distal ends 284 of strut wires 282 are attached to the distal portion of a tubular member 286. A
10 movable core wire 290 extends through a lumen 292 in tubular member 286 to a distal floppy section 294, where a helical spring coil 296 surrounds the distal portion 298 of core wire 290 and is attached to end point 300. There is an attachment point 302 of weld material or solder or other suitable material at the proximal portion of spring coil 296 where the distal portion 304 of sheath
15 member 306 is also attached to core wire 290. The lumen 308 of sheath member 306 is large enough so that as core wire 290 is pulled proximally, or tubular member 286 is advanced distally, the distal ends 284 of strut wires 282 move into lumen 308 and collapse filter membrane 280.

Moveable core wire 250 of the structure shown in Fig. 8 comprises a
20 floppy tip 252 where a helical spring coil 254 encompasses the distal portion 256 of core wire 250. A basket wire structure component of two or more basket wires 258 supports a filter membrane 260 on the distal portion 262 of the basket structure. Distal ends 264 of the basket wires 258 are encompassed by a radiopaque marker or crimp band 266 that is attached to
25 core wire 250 and/or spring coil 254. The proximal ends 268 of basket wires

CRD-0991

258 are attached to the distal portion of a sheath 270 that surrounds core wire 250. Sheath 270 moves slidably over core wire 250 so that when sheath 270 is pulled proximally into core wire 250, filter membrane 250 collapses.

In Fig. 9, a basket 320 comprising from four to eight strut wires 322 is secured by a distal fixed grommet 324 and a proximal slidable grommet 326. Grommet 326 is slidable over core wire 328. Filter membrane 330 is attached to or arranged upon basket 320, with the proximal section 332 of the membrane 330 being open to flow, represented by arrows 334. The distal portion 336 of membrane 330 forms a conical shape 340 that extends proximally. The filter may be deployed by, for example, a sheath or a tube fixed to the proximal slidable crimp band 326. This design is optimized for perfusion and emboli collection. For example, as more emboli is collected, it tends to collect in outer, non-filter areas, leaving the holes open for perfusion.

Membrane 330 preferably has holes only in distal section 336/340, which holes are arranged as described above. It is believed that under normal, substantially laminar flow conditions debris or emboli 342 will tend to collect in annular recesses 344.

To close and capture emboli, as shown in Fig. 10, slidable grommet 326 is moved proximally to collapse basket 320 and membrane 330. This may be accomplished with, for example, sheath 350 or a fixed tubular member or other apparatus that is preferably slidable over the core wire.

The wires, membrane, and other materials of this exemplary embodiment are consistent with those described above.

In the exemplary embodiment of the invention shown in Fig. 11, a hose 360 is attached to a cardiopulmonary bypass introducer member 362 that is

CRD-0991

positioned adjacent to and sealingly connected to a patient's blood vessel, such as the aorta 364. Introducer member 362 comprises a housing 366 with a flexible or rigid flange 368, a distal member 370, and a proximal connector member 372. Housing 366 comprises at least two lumens, one of which 374 is
5 in fluid communication with lumen 376 of hose 360. Another lumen 378 extends from a port 380 in Y-connector 382 to a distal opening 384 in a distal surface 386 of distal member 370. Lumen 374 terminates in distal opening 388 in distal surface 386.

Lumen 378 preferably comprises a rigid or semi-rigid sheath 390 which
10 is sealingly connected at port 380 by an O-ring 392 or a comparable sealing member and which extends distally, for example, from about two to about twenty centimeters, from distal flange 368. A filter system 394 as described in detail above is introduced through sheath 396 and is positioned downstream in aorta 364. Filter system 394 may be operatively connected via guidewire 398
15 to a handle. The filter system with captured emboli may be collapsed by pulling filter system 394 proximally so that struts 400 contact the distal end 402 of sheath 386.

In another exemplary embodiment of the invention, as shown in Fig.12, a small introducer sheath or guide catheter 410 may be inserted through an
20 incision into an artery 412 such as the ascending aorta prior to insertion of a bypass cannula or prior to cross-clamping of the aorta. A vascular filter system 414 comprising a guidewire 416 and a filter membrane 418 on a filter basket 420 is advanced through sheath 410 into artery 412. Basket 420 opens so that any emboli in blood flowing in the direction of arrow 422 will be captured in filter
25 membrane 418. Filter membrane 418 in a collapsed state with any captured

CRD-0991

emboli may be withdrawn proximally through sheath 410. The vascular filter system shown will operate as described above.

The preceding specific exemplary embodiments are illustrative of the practice of the invention. It is to be understood, however, that other expedients
5 known to those skilled in the art or disclosed herein, may be employed without departing from the spirit of the invention or the scope of the appended claims.

CRD-0991

IN THE CLAIMS:

What is claimed is:

1. A cardiopulmonary bypass filter system comprising:

a housing having distal and proximal ends, the proximal end

5 comprising a connector adapted to connect to at least one hose and the distal end comprising a distal member having first and second openings, wherein the housing comprises a first lumen adapted to be in fluid communication with the at least one hose and one of the first and second openings and a second lumen extending from a port to the other

10 of the first and second openings in the housing distal member; and

a vascular filter system comprising a collapsible filter advancable through the housing port, said vascular filter system comprising (a) a filter membrane support structure, and (b) a filter membrane attached to said filter membrane support structure, said filter membrane having

15 openings, wherein said openings have variable diameters, and wherein the diameter of said openings range from about 20 to about 300 microns.

2. The filter system of claim 1, wherein the housing is adapted to be
- 20 connected to a cardiopulmonary bypass machine.
3. The filter system of claim 1, wherein said housing has a distal flange.
 4. The filter system of claim 3, wherein said flange is rigid or flexible.

CRD-0991

5. The filter system of claim 1, wherein said two lumens form a substantially V-shape.

6. The filter system of claim 1, wherein said housing distal member is capable of extending into a blood vessel.

7. The filter system of claim 1 wherein said openings are non-uniformly spaced.

8. The filter system of claim 1 wherein said openings comprise fibers attached to said openings to increase embolic capture.

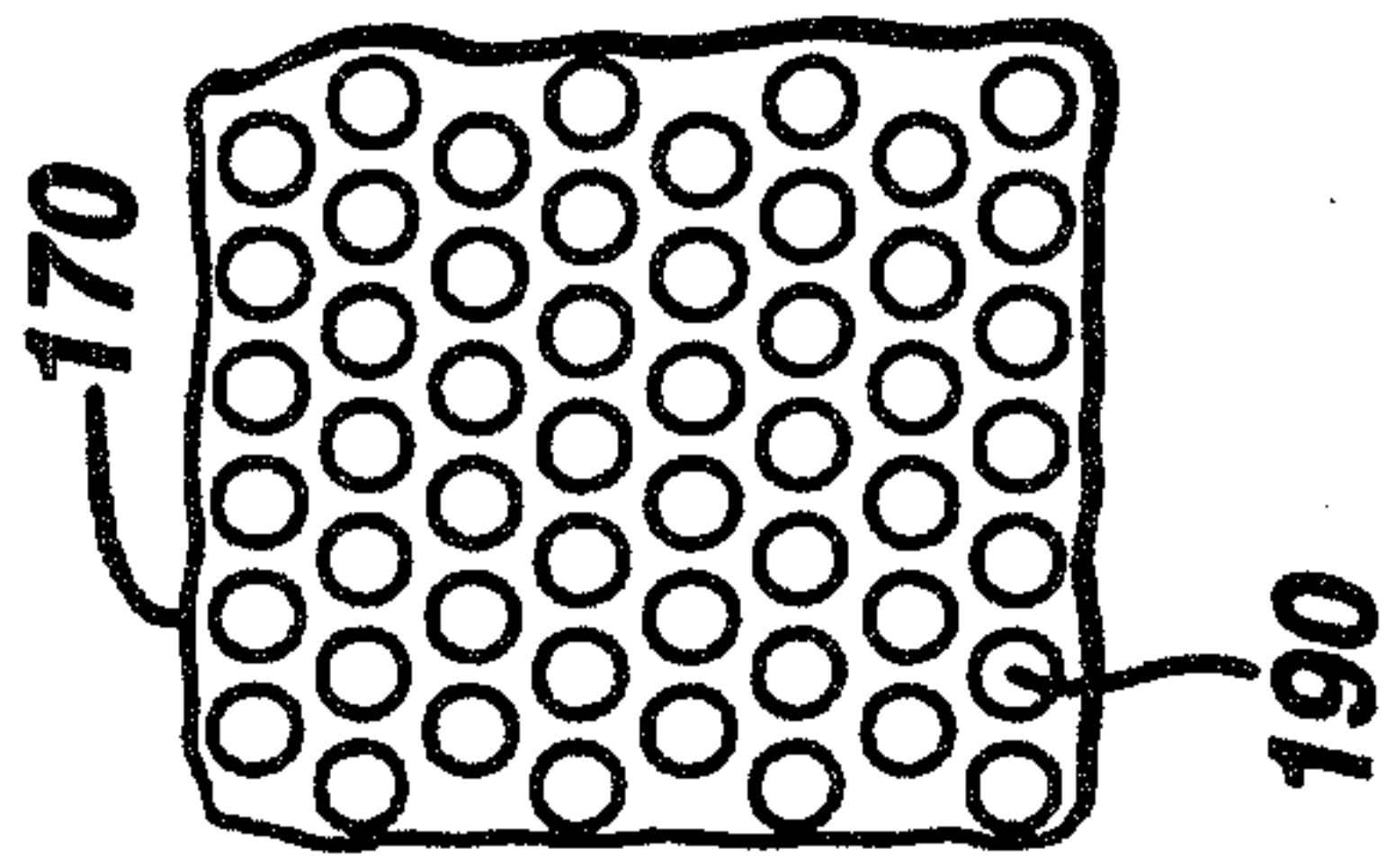

FIG. 3

FIG. 4

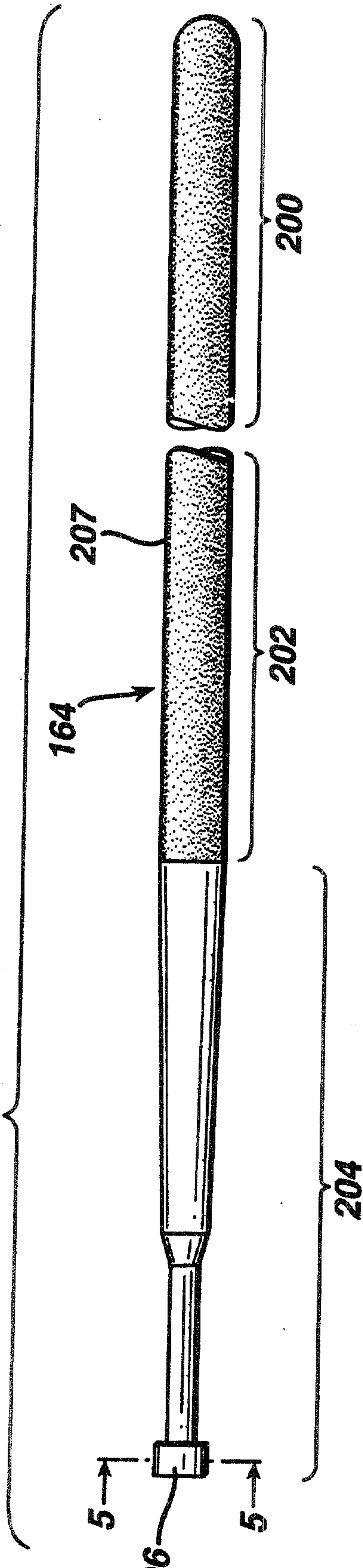

FIG. 5

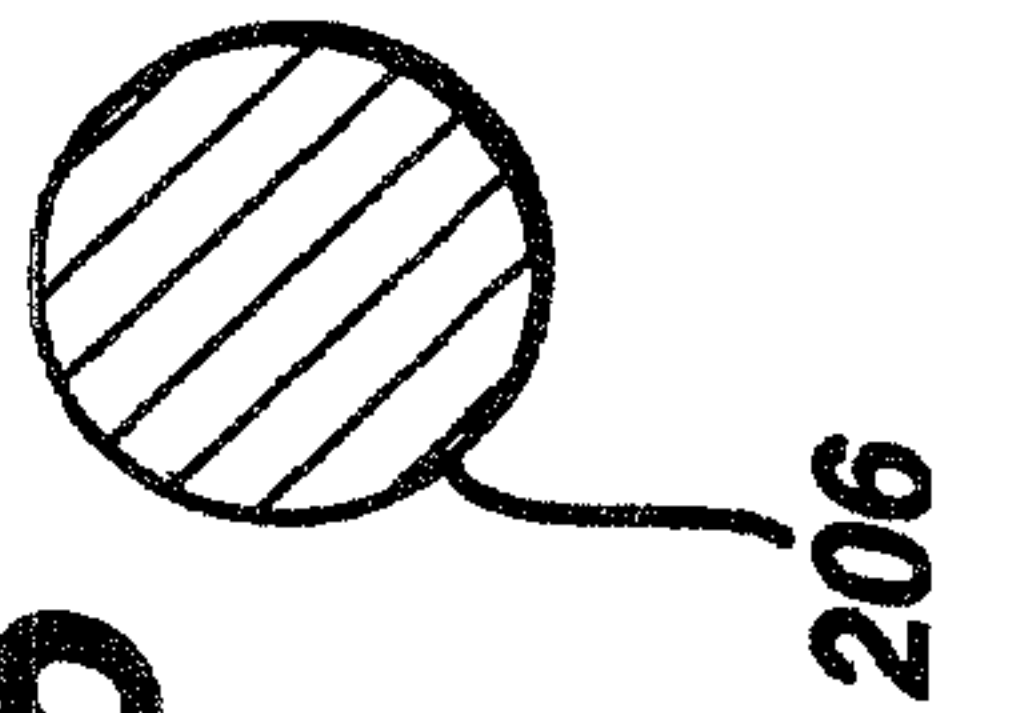

FIG. 6

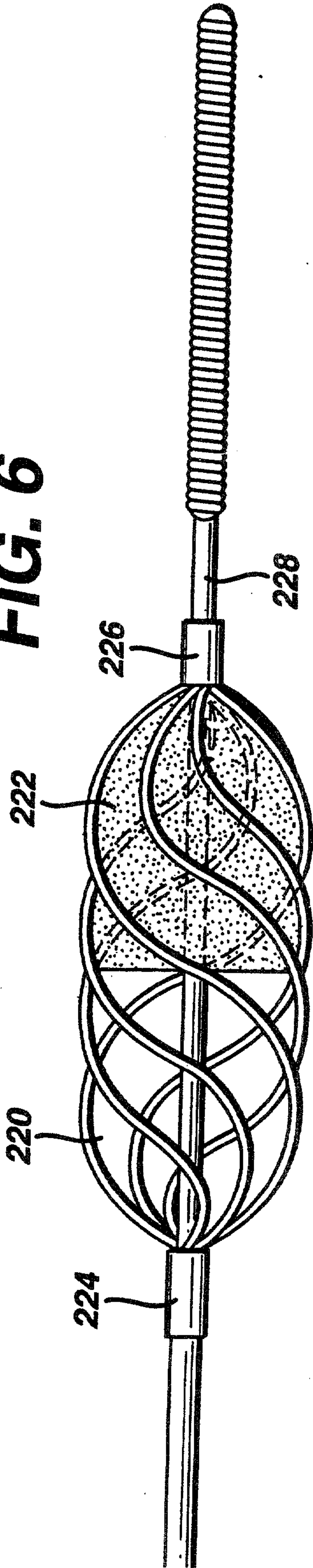

FIG. 7

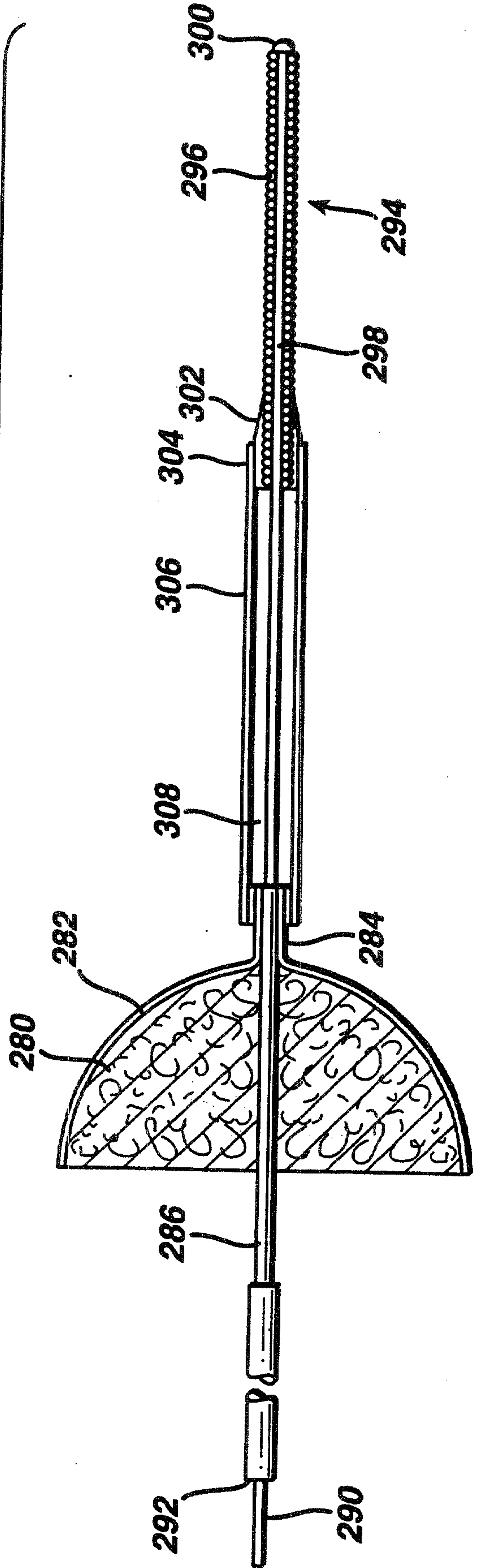
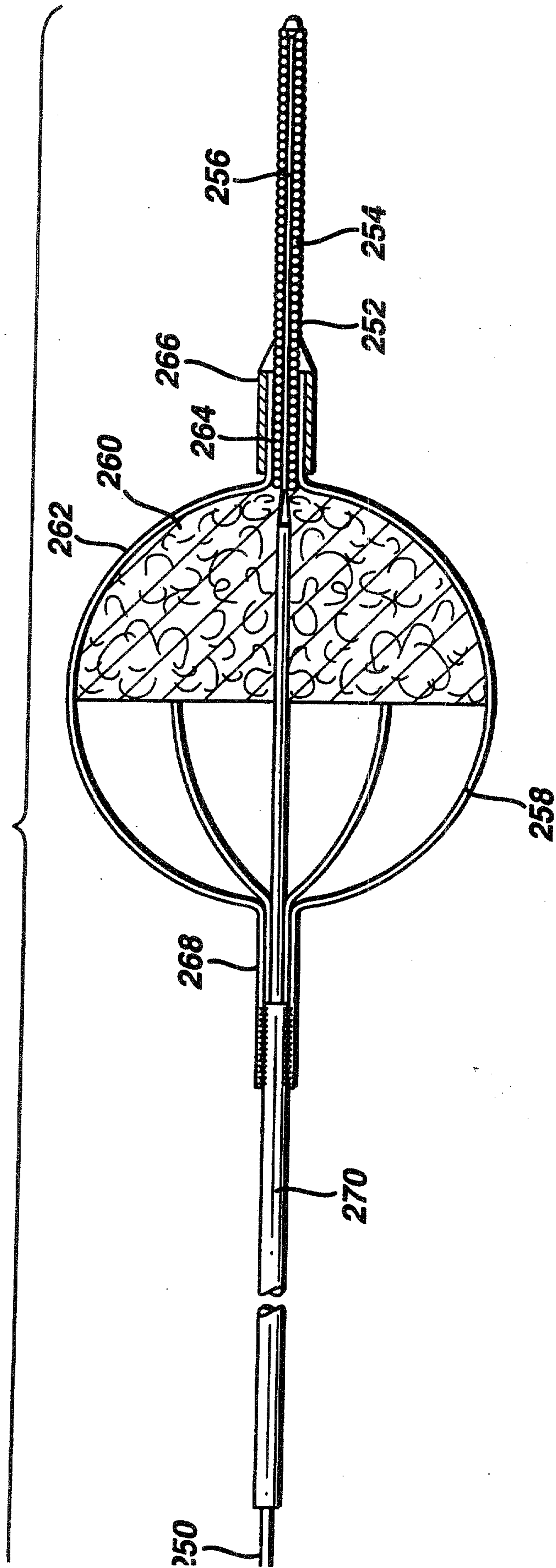

FIG. 8



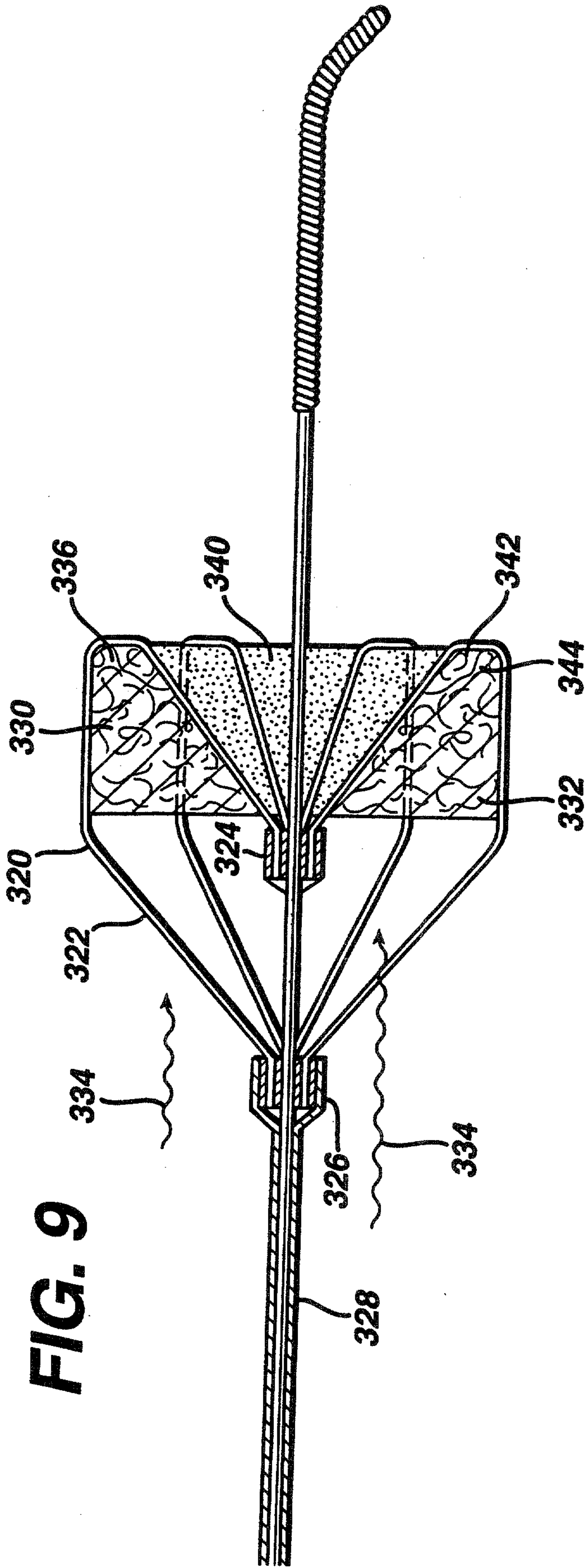

FIG. 9

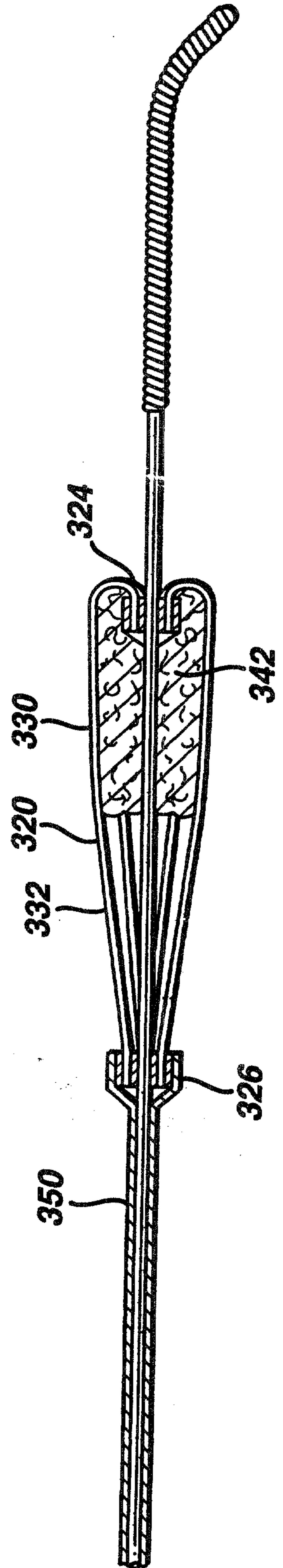

FIG. 10

FIG. 12

