



INTERNATIONAL APPLICATION PUBLISHED UNDER THE PATENT COOPERATION TREATY (PCT)

(51) International Patent Classification⁶ : C09K 19/00, F21V 1/08, G03H 1/02	A1	(11) International Publication Number: WO 98/04650 (43) International Publication Date: 5 February 1998 (05.02.98)
(21) International Application Number: PCT/US97/12577 (22) International Filing Date: 11 July 1997 (11.07.97) (30) Priority Data: 08/680,292 12 July 1996 (12.07.96) US (71) Applicant: SCIENCE APPLICATIONS INTERNATIONAL CORPORATION [US/US]; 10260 Campus Point Drive, San Diego, CA 92121-1578 (US). (72) Inventors: SUTHERLAND, Richard, L.; 447 Satellite Avenue, Dayton, OH 45415 (US). NATARAJAN, Lalgudi, V.; 2341 Apricot Drive, Beavercreek, OH 45431 (US). TONDIGLIA, Vincent, P.; 550 Elberon Avenue, Dayton, OH 45403 (US). CRANE, Robert, L.; 200 Lewiston Road, Kettering, OH 45429 (US). (74) Agents: POPLAWSKI, Edward, G. et al.; Pretty, Schroeder & Poplawski, 444 South Flower Street, Los Angeles, CA 90071 (US).	(81) Designated States: AL, AM, AT, AU, AZ, BB, BG, BR, BY, CA, CH, CN, CZ, DE, DK, EE, ES, FI, GB, GE, HU, IL, IS, JP, KE, KG, KP, KR, KZ, LK, LR, LS, LT, LU, LV, MD, MG, MK, MN, MW, MX, NO, NZ, PL, PT, RO, RU, SD, SE, SG, SI, SK, SL, TJ, TM, TR, TT, UA, UG, UZ, VN, YU, ARIPO patent (GH, KE, LS, MW, SD, SZ, UG, ZW), Eurasian patent (AM, AZ, BY, KG, KZ, MD, RU, TJ, TM), European patent (AT, BE, CH, DE, DK, ES, FI, FR, GB, GR, IE, IT, LU, MC, NL, PT, SE), OAPI patent (BF, BJ, CF, CG, CI, CM, GA, GN, ML, MR, NE, SN, TD, TG). Published <i>With international search report. Before the expiration of the time limit for amending the claims and to be republished in the event of the receipt of amendments.</i>	
(54) Title: SWITCHABLE VOLUME HOLOGRAM MATERIALS AND DEVICES		
(57) Abstract <p>A new photopolymerizable material allows single-step, fast recording of volume holograms with properties that can be electrically controlled. The material is a new composition for a polymer-dispersed liquid crystals (PDLCs) comprising a homogeneous mixture of a nematic liquid crystal and a multifunctional penta acrylate monomer, with photoinitiator, coinitiator and cross-linking agent. The preferred components and concentrations are the monomer dipentaerythritol hydroxy penta acrylate, ~10-40 wt.% of the liquid crystal E7, 5-15 wt.% of the cross-linking monomer N-vinylpyrrolidone, 10⁻³ to 10⁻⁴ gram moles of the coinitiator N- phenylglycine, and 10⁻⁵ to 10⁻⁶ gram moles of the photoinitiator Rose Bengal. About 6 wt.% of the surfactant octanoic acid may also be added. The PDLC material is exposed with coherent light to produce an interference pattern inside the material. Photopolymerization of the new PDLC material produces a hologram of clearly separated liquid crystal domains and cured polymer. Volume transmission gratings made with the new PDLC material can be electrically switched between nearly 100 % diffraction efficiency and nearly 0 % diffraction efficiency. By increasing the frequency of the switching voltage, switching voltages in the range of 50 Vrms can be achieved. The use of the surfactant allows low switching voltages at lower frequencies than without the surfactant. In an alternative embodiment, a new PDLC material can be utilized to form reflection gratings, including switchable reflection gratings. In still further embodiments, a new photopolymerizable material can be used to form switchable subwavelength gratings. By further processing, static transmission reflection, and subwavelength PDLC materials can be formed.</p>		

FOR THE PURPOSES OF INFORMATION ONLY

Codes used to identify States party to the PCT on the front pages of pamphlets publishing international applications under the PCT.

AL	Albania	ES	Spain	LS	Lesotho	SI	Slovenia
AM	Armenia	FI	Finland	LT	Lithuania	SK	Slovakia
AT	Austria	FR	France	LU	Luxembourg	SN	Senegal
AU	Australia	GA	Gabon	LV	Latvia	SZ	Swaziland
AZ	Azerbaijan	GB	United Kingdom	MC	Monaco	TD	Chad
BA	Bosnia and Herzegovina	GE	Georgia	MD	Republic of Moldova	TG	Togo
BB	Barbados	GH	Ghana	MG	Madagascar	TJ	Tajikistan
BE	Belgium	GN	Guinea	MK	The former Yugoslav Republic of Macedonia	TM	Turkmenistan
BF	Burkina Faso	GR	Greece			TR	Turkey
BG	Bulgaria	HU	Hungary	ML	Mali	TT	Trinidad and Tobago
BJ	Benin	IE	Ireland	MN	Mongolia	UA	Ukraine
BR	Brazil	IL	Israel	MR	Mauritania	UG	Uganda
BY	Belarus	IS	Iceland	MW	Malawi	US	United States of America
CA	Canada	IT	Italy	MX	Mexico	UZ	Uzbekistan
CF	Central African Republic	JP	Japan	NE	Niger	VN	Viet Nam
CG	Congo	KE	Kenya	NL	Netherlands	YU	Yugoslavia
CH	Switzerland	KG	Kyrgyzstan	NO	Norway	ZW	Zimbabwe
CI	Côte d'Ivoire	KP	Democratic People's Republic of Korea	NZ	New Zealand		
CM	Cameroon			PL	Poland		
CN	China	KR	Republic of Korea	PT	Portugal		
CU	Cuba	KZ	Kazakstan	RO	Romania		
CZ	Czech Republic	LC	Saint Lucia	RU	Russian Federation		
DE	Germany	LI	Liechtenstein	SD	Sudan		
DK	Denmark	LK	Sri Lanka	SE	Sweden		
EE	Estonia	LR	Liberia	SG	Singapore		

SWITCHABLE VOLUME HOLOGRAM MATERIALS AND DEVICES

FIELD OF INVENTION

5 The present invention relates generally to photopolymerizable materials, and more specifically to polymer-dispersed liquid crystal materials suitable for recording volume holograms.

BACKGROUND OF THE INVENTION

10 Typical state-of-the-art holographic materials do not have an electro-optical nature which can be exploited for real time control of their optical properties. That is, once the hologram is fixed, its optical characteristics cannot be changed. Thus, it is seen that there is a need for materials that can record volume holograms with properties that can be electrically controlled.

15 Liquid crystals have long been utilized in the prior art for their ability to change their optical orientation in the presence of an electric field. Additionally, liquid crystals can dramatically increase the diffraction efficiency of a volume hologram of which they are a part. Together, these properties offer the very desirable possibility of electrically switching the diffraction efficiency of volume holograms for use in a wide variety of optical information processing and display applications.

20 The prior art has attempted to combine the properties of liquid crystals with holograms by a variety of methods. Unfortunately, most of these prior art devices are complex to manufacture and are not successful at offering all the advantages of volume holographic gratings.

30 One approach for combining the advantages of liquid crystals with volume holographic gratings has been to first make a holographic transmission grating by exposing a photopolymerizable material with a conventional two-beam apparatus for forming interference patterns inside the material. After exposure, the material is processed to produce voids where the greatest amount of exposure occurred, that is, along the grating lines, and then, in a further step, the pores are
35 infused with liquid crystals. Unfortunately, these materials are complex to manufacture and do not offer flexibility for *in situ* control over liquid crystal domain size, shape, density, or ordering.

Polymer-dispersed liquid crystals (PDLCS) are formed from a homogeneous mixture of prepolymer and liquid crystals. As the polymer cures, the liquid crystals separate out as a distinct microdroplet phase. If the polymer is a photopolymer, this phase separation occurs as the prepolymer is irradiated with light. If a photopolymerizable polymer-dispersed liquid crystal material is irradiated with light in a suitable pattern, a holographic transmission grating can be made inside the cured polymer comprising gratings of cured polymer separated by phase separated liquid crystals. The prior art has attempted to employ polymer-dispersed liquid crystal materials for writing volume gratings, but, despite a variety of approaches, has not been able to achieve high efficiency in the Bragg regime, high density (small grating spacing) capability, or low voltage (<100 Vrms) switching for films in the range of 15 microns thickness. The inability to make an electrically switchable volume hologram that can be switched at voltages less than 100 volts has been a particular deficiency in the prior art in that lower voltages are necessary to be compatible with conventional display and information processing technology.

OBJECTS OF THE INVENTION

It is, therefore, a principal object of the present invention to provide an improved polymer-dispersed liquid crystal system suitable for recording volume holograms.

It is a particular object of the present invention to provide a polymer-dispersed liquid crystal system that has a fast curing rate to produce small liquid crystal droplets, particularly in the range of 0.01-0.05 microns, for greater clarity of any resulting film and for writing finer gratings.

It is another object of the present invention to provide a single-step, fast holographic recording material.

It is a further object of the present invention to provide electrically switchable volume holograms that can be switched at voltages less than 100 volts.

It is also an object of the present invention to provide an improved polymer-dispersed liquid crystal system suitable for recording reflection gratings, including, in particular, switchable reflection gratings.

It is also an object of the present invention to provide an improved polymer-dispersed liquid crystal system suitable for recording subwavelength gratings, including, in particular switchable

subwavelength gratings.

These and other objects of the present invention will become apparent as the description of certain representative embodiments proceeds.

5

SUMMARY OF THE INVENTION

The present invention provides a novel photopolymerizable material for single-step, fast recording of volume holograms with properties that can be electrically controlled. The unique discovery of the present invention is a new homogeneous mixture of a nematic
10 liquid crystal and a multifunctional pentaacrylate monomer, with a photoinitiator, a coinitiator and a cross-linking agent, that accomplishes the objects of the invention, particularly the object of fast curing speed and small liquid crystal droplet size.

Accordingly, the present invention is directed to a polymer-
15 dispersed liquid crystal ("PDLC") material, comprising the monomer dipentaerythritol hydroxypentaacrylate, a liquid crystal, a cross-linking monomer, a coinitiator and a photoinitiator dye. The polymer-dispersed liquid crystal material may optionally further comprise a surfactant. The PDLC material may be approximately 10-40 wt% of the
20 liquid crystal. The PDLC material may be approximately 5-15 wt% of the cross-linking monomer. The amount of the coinitiator may be 10^{-3} to 10^{-4} gram moles and the amount of the photoinitiator dye may be 10^{-5} to 10^{-6} gram moles. The surfactant, when present, may be up to approximately 6 wt% of the PDLC material.

25 The present invention is also directed to an electrically switchable hologram, comprising a pair of transparent plates, and sandwiched between the transparent plates, a volume hologram made by exposing an interference pattern inside a polymer-dispersed liquid crystal material, the polymer-dispersed liquid crystal material
30 comprising, before exposure, the monomer dipentaerythritol hydroxypentaacrylate, a liquid crystal, a cross-linking monomer, a coinitiator and a photoinitiator dye. The electrically switchable hologram may optionally further comprise a surfactant.

The present invention is additionally directed to a method
35 for reducing the switching voltage needed to switch the optical orientation of liquid crystals in a polymer-dispersed liquid crystal material, comprising the step of using alternating current switching voltage frequencies greater than 1000 Hz.

40 It is a feature of the present invention that a very clear and orderly separation of liquid crystal from cured polymer results,

so as to produce high quality holographic transmission gratings. The prior art has achieved generally only a distribution of large and small liquid crystal domains and not the clear, orderly separation made possible by the present invention.

5 It is also a feature of the present invention that volume Bragg gratings with small grating spacings (approximately 4,000 lines per mm) can be recorded.

 It is another feature of the present invention that *in situ* control of domain size, shape, density, and ordering is allowed.

10 It is yet another feature of the present invention that holograms can be recorded using conventional optical equipment and techniques.

 It is a further feature of the present invention that a unique photopolymerizable prepolymer material is employed. This unique
15 material can be used to record holograms in a single step.

 It is also a feature of the present invention that the PDLC material has an anisotropic spatial distribution of phase-separated liquid crystal droplets within a photochemically-cured polymer matrix.

20 It is an advantage of the present invention that single-step recording is nearly immediate and requires no later development or further processing.

 It is another advantage of the present invention that uses thereof are not limited to transmission gratings, but can be extended to other holograms such as optical storage devices and reflection and
25 transmission pictorial holograms.

 It is also an advantage that, unlike holograms made with conventional photograph-type films or dichromated gels, holograms in accordance with the present invention can be exposed in a one-step process that requires little or no further processing.

30 It is a further advantage of the present invention that reflection, transmission and pictorial holograms made using the teachings provided herein can be switched on and off.

It is also an advantage of the present invention that switchable reflection gratings can be formed using positive and negative dielectric anisotropy liquid crystals.

5 These and other features and advantages of the present invention will become apparent as the description of certain representative embodiments proceeds.

BRIEF DESCRIPTION OF THE FIGURES

10 The present invention will be more clearly understood from a reading of the following detailed description in conjunction with the accompanying figures wherein:

FIG. 1 is a cross-sectional view of an electrically switchable hologram made of an exposed polymer-dispersed liquid crystal material according to the teachings of the present invention;

15 FIG. 2 is a graph of the normalized net transmittance and normalized net diffraction efficiency of a hologram made according to the teachings of the present invention (without the addition of a surfactant) versus the rms voltage applied across the hologram;

20 FIG. 3 is a graph of both the threshold and complete switching rms voltages needed for switching a hologram made according to the teachings of the present invention to minimum diffraction efficiency versus the frequency of the rms voltage;

25 FIG. 4 is a graph of the normalized diffraction efficiency as a function of the applied electric field for a PDLC material formed with 34% by weight liquid crystal surfactant present and a PDLC material formed with 29% by weight liquid crystal and 4% by weight surfactant;

30 FIG. 5 is a graph showing the switching response time data for the diffracted beam in the surfactant-containing PDLC material in FIG. 5;

FIG. 6 is a graph of the normalized net transmittance and the normalized net diffraction efficiency of a hologram made according to the teachings of the present invention versus temperature;

FIG. 7 is an elevational view of typical experimental arrangement for recording reflection gratings;

5 FIGS. 8a and 8b are elevational views of a reflection grating in accordance with the present invention having periodic planes of polymer channels and PDLC channels disposed parallel to the front surface in the absence of a field (FIG. 8a) and with an electric field applied (FIG. 8b) wherein the liquid-crystal utilized in the formation of the grating has a positive dielectric anisotropy;

10 FIGS. 9a and 9b are elevational views of a reflection grating in accordance with the invention having periodic planes of polymer channels and PDLC channels disposed parallel to the front surface of the grating in the absence of an electric field (FIG. 9a) and with an electric field applied (FIG. 9b) wherein the liquid crystal utilized in the formation of the grating has a negative
15 dielectric anisotropy;

FIG. 10a is an elevational view of a reflection grating in accordance with the invention disposed within a magnetic field generated by Helmholtz coils;

20 FIGS. 10b and 10c are elevational views of the reflection grating of FIG. 10a in the absence of an electric field (FIG. 10b) and with an electric field applied (FIG. 10c);

25 FIGS. 11a and 11b are representative side views of a slanted transmission grating (FIG. 11a) and a slanted reflection grating (FIG. 11b) showing the orientation of the grating vector G of the periodic planes of polymer channels and PDLC channels;

FIG. 12 is an elevational view of a reflection grating formed in accordance with the invention while a shear stress field is applied;

30 FIG. 13 is an elevational view of a subwavelength grating in accordance with the present invention having periodic planes of polymer channels and PDLC channels disposed perpendicular to the front surface of the grating;

FIG. 14a is an elevational view of a switchable

subwavelength grating in accordance with the present invention wherein the subwavelength grating functions as a half wave plate whereby the polarization of the incident radiation is rotated by 90° ;

5 FIG. 14b is an elevational view of the switchable half wave plate shown in FIG. 14a disposed between crossed polarizers whereby the incident light is transmitted;

10 FIGS. 14c and 14d are side views of the switchable half wave plate and crossed polarizers shown in FIG. 14b and showing the effect of the application of a voltage to the plate whereby the polarization of the light is no longer rotated and thus blocked by the second polarizer;

15 FIG. 15a is a side view of a switchable subwavelength grating in accordance with the invention wherein the subwavelength grating functions as a quarter wave plate whereby plane polarized light is transmitted through the subwavelength grating, retroreflected by a mirror and reflected by the beam splitter;

20 FIG. 15b is a side view of the switchable subwavelength grating of FIG. 15a and showing the effect of the application of a voltage to the plate whereby the polarization of the light is no longer modified, thereby permitting the reflected light to pass through the beam splitter;

25 FIGS. 16a and 16b are elevational views of a transmission grating in accordance with the present invention having periodic planes of polymer channels and PDLC channels disposed perpendicular to the front face of the grating in the absence of an electric field (FIG. 17a) and with an electric field applied (FIG. 17b) wherein the liquid crystal utilized in formation of the grating has a positive dielectric anisotropy; and

30 FIG. 17 is a side view of five subwavelength gratings wherein the gratings are stacked and connected electrically in parallel thereby reducing the switching voltage of the subwavelength grating.

DETAILED DESCRIPTION

In accordance with present invention there is provided a polymer dispersed liquid crystal ("PDLC") material comprising a monomer, a dispersed liquid crystal, a cross-linking monomer, a cointiator and a photoinitiator dye. These PDLC materials exhibit clear and orderly separation of the liquid crystal and cured polymer, whereby the PDLC material advantageously provides high quality holographic gratings. The PDLC materials of the present invention are also advantageously formed in a single step. The present invention also utilizes a unique photopolymerizable prepolymer material that permits *in situ* control over characteristics of the resulting gratings, such as domain size, shape, density, ordering, and the like. Furthermore, methods and materials of the present invention can be used to prepare PDLC materials that function as switchable transmission or reflection gratings.

Polymer dispersed liquid crystal materials, methods, and devices contemplated for use in the practice of the present invention are also described in R.L. Sutherland et al., "Bragg Gratings in an Acrylate Polymer Consisting of Periodic Polymer-Dispersed Liquid-Crystal Planes," *Chemistry of Materials*, No. 5, pp. 1533-1538 (1993); in R.L. Sutherland et al., "Electrically switchable volume gratings in polymer-dispersed liquid crystals," *Applied Physics Letters*, Vol. 64, No. 9, pp. 1074-1076 (1984); and T.J. Bunning et al., "The Morphology and Performance of Holographic Transmission Gratings Recorded in Polymer Dispersed Liquid Crystals," *Polymer*, Vol. 36, No. 14, pp. 2699-2708 (1995), all of which are fully incorporated by reference into this Detailed Description. Copending patent applications Serial Nos. 08/273,436 and 08/273,437 Sutherland et al., titled "Switchable Volume Hologram Materials and Devices," and "Laser Wavelength Detection and Energy Dosimetry Badge," respectively, include background material on the formation of transmission gratings inside volume holograms.

The process by which a hologram is formed according to the invention is controlled primarily by the choice of components used to prepare the homogeneous starting mixture, and to a lesser extent by the intensity of the incident light pattern. The preferred polymer-dispersed liquid crystal ("PDLC") material employed in the practice of the present invention creates a switchable hologram in a single step. A new feature of the preferred PDLC material is that illumination by an inhomogeneous, coherent light pattern initiates a patterned, anisotropic diffusion (or counter diffusion) of polymerizable monomer and second phase material, particularly liquid crystal ("LC") for this

application. Thus, alternating well-defined channels of second phase-rich material, separated by well-defined channels of nearly pure polymer, are produced in a single-step process.

5 The resulting preferred PDLC material has an anisotropic spatial distribution of phase-separated LC droplets within the photochemically cured polymer matrix. Prior art PDLC materials made by a single-step process can achieve at best only regions of larger LC bubbles and smaller LC bubbles in a polymer matrix. The large bubble sizes are highly scattering which produces a hazy appearance and multiple order diffractions, in contrast to the well-defined first order diffraction and zero order diffraction made possible by the small LC bubbles of the preferred PDLC material in well-defined channels of LC-rich material. Reasonably well-defined alternately LC-rich channels and nearly pure polymer channels in a PDLC material are possible by 10 multi-step processes, but such processes do not achieve the precise morphology control over LC droplet size and distribution of sizes and widths of the polymer and LC-rich channels made possible by the preferred PDLC material. 15

20 The sample is prepared by coating the mixture between two indium-tin-oxide (ITO) coated glass slides separated by spacers of nominally 10-20 μm thickness. The sample is placed in a conventional holographic recording setup. Gratings are typically recorded using the 488 nm line of an Argon ion laser with intensities of between about 0.1-100 mW/cm^2 and typical exposure times of 30-120 seconds. The angle 25 between the two beams is varied to vary the spacing of the intensity peaks, and hence the resulting grating spacing of the hologram. Photopolymerization is induced by the optical intensity pattern. A more detailed discussion of exemplary recording apparatus can be found in R.L. Sutherland, et al., "Switchable holograms in new photopolymer-liquid crystal composite materials," Society of Photo-Optical Instrumentation Engineers (SPIE), Proceedings Reprint, Volume 2404, 30 reprinted from Diffractive and Holographic Optics Technology II (1995), incorporated herein by reference.

35 The features of the PDLC material are influenced by the components used in the preparation of the homogeneous starting mixture and, to a lesser extent, by the intensity of the incident light pattern. In the preferred embodiment, the prepolymer material comprises a mixture of a photopolymerizable monomer, a second phase material, a photoinitiator dye, a coiniciator, a chain extender (or

cross-linker), and, optionally, a surfactant.

In the preferred embodiment, the two major components of the prepolymer mixture are the polymerizable monomer and the second phase material, which are preferably completely miscible. Highly functionalized monomers are preferred because they form densely cross-linked networks which shrink to some extent and tend to squeeze out the second phase material. As a result, the second phase material is moved anisotropically out of the polymer region and, thereby, separated into well-defined polymer-poor, second phase-rich regions or domains. Highly functionalized monomers are also preferred because the extensive cross-linking associated with such monomers yields fast kinetics, allowing the hologram to form relatively quickly, whereby the second phase material will exist in domains of less than approximately 0.1 μm .

Highly functionalized monomers, however, are relatively viscous. As a result, these monomers do not tend to mix well with other materials, and they are difficult to spread into thin films. Accordingly, it is preferable to utilize a mixture of penta-acrylates in combination with di-, tri-, and/or tetra-acrylates in order to optimize both the functionality and viscosity of the prepolymer material. Suitable acrylates, such as triethyleneglycol diacrylate, trimethylolpropane triacrylate, pentaerythritol triacrylate, pentaerythritol tetracrylate, pentaerythritol pentacrylate, and the like can be used in accordance with the present invention. In the preferred embodiment, it has been found that an approximately 1:4 mixture of tri- to penta-acrylate facilitates homogeneous mixing while providing a favorable mixture for forming 10-20 μm films on the optical plates.

The second phase material of choice for use in the practice of the present invention is a liquid crystal. This also allows an electro-optical response for the resulting hologram. The concentration of LC employed should be large enough to allow a significant phase separation to occur in the cured sample, but not so large as to make the sample opaque or very hazy. Below about 20% by weight very little phase separation occurs and diffraction efficiencies are low. Above about 35% by weight, the sample becomes highly scattering, reducing both diffraction efficiency and transmission. Samples fabricated with approximately 25% by weight typically yield good diffraction efficiency and optical clarity. In prepolymer mixtures utilizing a surfactant, the concentration of LC may be

increased to 35% by weight without loss in optical performance by adjusting the quantity of surfactant. Suitable liquid crystals contemplated for use in the practice of the present invention include the mixture of cyanobiphenyls marketed as E7 by Merck, 4'-n-pentyl-4-cyanobiphenyl, 4'-n-heptyl-4-cyanobiphenyl, 4'-octaoxy-4-cyano
5 biphenyl, 4'-pentyl-4-cyanoterphenyl, α -methoxybenzylidene-4'-butylaniline, and the like. Other second phase components are also possible.

The preferred polymer-dispersed liquid crystal material employed in the practice of the present invention is formed from a
10 prepolymer material that is a homogeneous mixture of a polymerizable monomer comprising dipentaerythritol hydroxypentacrylate (available, for example, from Polysciences, Inc., Warrington, Pennsylvania), approximately 10-40 wt% of the liquid crystal E7 (which is a mixture
15 of cyanobiphenyls marketed as E7 by Merck and also available from BDH Chemicals, Ltd., London, England), the chain-extending monomer N-vinylpyrrolidone ("NVP") (available from the Aldrich Chemical Company, Milwaukee, Wisconsin), coinitiator N-phenylglycine ("NPG") (also available from the Aldrich Chemical Company, Milwaukee, Wisconsin), and
20 the photoinitiator dye rose bengal ester; (2,4,5,7-tetraiodo-3',4',5',6'-tetrachlorofluorescein-6-acetate ester) marketed as RBAX by Spectragraph, Ltd., Maumee, Ohio). Rose bengal is also available as rose bengal sodium salt (which must be esterfied for solubility) from the Aldrich Chemical Company. This system has a very fast curing
25 speed which results in the formation of small liquid crystal microdroplets.

The mixture of liquid crystal and prepolymer material are homogenized to a viscous solution by suitable means (e.g., ultrasonification) and spread between indium-tin-oxide ("ITO") coated
30 glass slides with spacers of nominally 15-100 μm thickness and, preferably, 10-20 μm thickness. The ITO is electrically conductive and serves as an optically transparent electrode. Preparation, mixing and transfer of the prepolymer material onto the glass slides are preferably done in the dark as the mixture is extremely sensitive to
35 light.

The sensitivity of the prepolymer materials to light intensity is dependent on the photoinitiator dye and its concentration. A higher dye concentration leads to a higher sensitivity. In most cases, however, the solubility of the photoinitiator dye limits the

concentration of the dye and, thus, the sensitivity of the prepolymer material. Nevertheless, it has been found that for more general applications photoinitiator dye concentrations in the range of 0.2-0.4% by weight are sufficient to achieve desirable sensitivities and allow for a complete bleaching of the dye in the recording process, resulting in colorless final samples. Photoinitiator dyes that are useful in generating PDLC materials in accordance with the present invention are rose bengal ester (2,4,5,7-tetraiodo-3',4',5',6'-tetrachlorofluorescein-6-acetate ester); rose bengal sodium salt; eosin; eosin sodium salt; 4,5-diiodosuccinyl fluorescein; camphorquinone; methylene blue, and the like. These dyes allow a sensitivity to recording wavelengths across the visible spectrum from nominally 400 nm to 700 nm. Suitable near-infrared dyes, such as cationic cyanine dyes with trialkylborate anions having absorption from 600-900 nm as well as merocyanine dyes derived from spiropyran should also find utility in connection with the present invention.

The coiniciator employed in the practice of the present invention controls the rate of curing in the free radical polymerization reaction of the prepolymer material. Optimum phase separation and, thus, optimum diffraction efficiency in the resulting PDLC material, are a function of curing rate. It has been found that favorable results can be achieved utilizing coiniciator in the range of 2-3% by weight. Suitable coiniciators include N-phenyl glycine; triethylene amine; triethanolamine; N,N-dimethyl-2,6-diisopropyl aniline, and the like.

Other suitable dyes and dye coiniciator combinations that should be suitable for use in the present invention, particularly for visible light, include eosin and triethanolamine; camphorquinone and N-phenylglycine; fluorescein and triethanolamine; methylene blue and triethanolamine or N-phenylglycine; erythrosin B and triethanolamine; indolinocarbocyanine and triphenyl borate; iodobenzospiryran and triethylamine, and the like.

The chain extender (or cross linker) employed in the practice of the present invention helps to increase the solubility of the components in the prepolymer material as well as increase the speed of polymerization. The chain extender is preferably a smaller vinyl monomer as compared with the pentacrylate, whereby it can react with the acrylate positions in the pentaacrylate monomer, which are not easily accessible to neighboring pentaacrylate monomers due to steric

hindrance. Thus, reaction of the chain extender monomer with the polymer increases the propagation length of the growing polymer and results in high molecular weights. It has been found that chain extender in general applications in the range of 10-18% by weight maximizes the performance in terms of diffraction efficiency. In the preferred embodiment, it is expected that suitable chain extenders can be selected from the following: N-vinyl pyrrolidone; N-vinyl pyridine; acrylonitrile; N vinyl carbazole, and the like.

It has been found that the addition of a surfactant material, namely, octanoic acid, in the prepolymer material lowers the switching voltage and also improves the diffraction efficiency. In particular, the switching voltage for PDLC materials containing a surfactant are significantly lower than those of a PDLC material made without the surfactant. While not wishing to be bound by any particular theory, it is believed that these results may be attributed to the weakening of the anchoring forces between the polymer and the phase-separated LC droplets. SEM studies have shown that droplet sizes in PDLC materials including surfactants are reduced to the range of 30-50 nm and the distribution is more homogeneous. Random scattering in such materials is reduced due to the dominance of smaller droplets, thereby increasing the diffraction efficiency. Thus, it is believed that the shape of the droplets becomes more spherical in the presence of surfactant, thereby contributing to the decrease in switching voltage.

For more general applications, it has been found that samples with as low as 5% by weight of surfactant exhibit a significant reduction in switching voltage. It has also been found that, when optimizing for low switching voltages, the concentration of surfactant may vary up to about 10% by weight (mostly dependent on LC concentration) after which there is a large decrease in diffraction efficiency, as well as an increase in switching voltage (possibly due to a reduction in total phase separation of LC). Suitable surfactants include octanoic acid; heptanoic acid; hexanoic acid; dodecanoic acid; decanoic acid, and the like.

In samples utilizing octanoic acid as the surfactant, it has been observed that the conductivity of the sample is high, presumably owing to the presence of the free carboxyl (COOH) group in the octanoic acid. As a result, the sample increases in temperature when a high frequency (~2 KHz) electrical field is applied for prolonged periods

of time. Thus, it is desirable to reduce the high conductivity introduced by the surfactant, without sacrificing the high diffraction efficiency and the low switching voltages. It has been found that suitable electrically switchable gratings can be formed from a polymerizable monomer, vinyl neonanoate ("VN") $C_8H_{17}CO_2CH=CH_2$, commercially available from the Aldrich Chemical Co. in Milwaukee, Wisconsin. Favorable results have also been obtained where the chain extender N-vinyl pyrrolidone ("NVP") and the surfactant octanoic acid are replaced by 6.5% by weight VN. VN also acts as a chain extender due to the presence of the reactive acrylate monomer group. In these variations, high optical quality samples were obtained with about 70% diffraction efficiency, and the resulting gratings could be electrically switched by an applied field of $6V/\mu m$.

P DLC materials in accordance with the present invention may also be formed using a liquid crystalline bifunctional acrylate as the monomer ("LC monomer"). The LC monomers have an advantage over conventional acrylate monomers due to their high compatibility with the low molecular weight nematic LC materials, thereby facilitating formation of high concentrations of low molecular weight LC and yielding a sample with high optical quality. The presence of higher concentrations of low molecular weight LCs in the P DLC material greatly lowers the switching voltages (e.g., to $\sim 2V/\mu m$). Another advantage of using LC monomers is that it is possible to apply low AC or DC fields while recording holograms to pre-align the host LC monomers and low molecular weight LC so that a desired orientation and configuration of the nematic directors can be obtained in the LC droplets. The chemical formulae of several suitable LC monomers are as follows:

- $CH_2=CH-COO-(CH_2)_6O-C_6H_5-C_6H_5-COO-CH=CH_2$
- $CH_2=CH-(CH_2)_8-COO-C_6H_5-COO-(CH_2)_8-CH=CH_2$
- $H(CF_2)_{10}CH_2O-CH_2-C(=CH_2)-COO-(CH_2CH_2O)_3CH_2CH_2O-COO-CH_2-C(=CH_2)-CH_2O(CF_2)_{10}H$

Semifluorinated polymers are known to show weaker anchoring properties and also significantly reduced switching fields. Thus, it is believed that semifluorinated acrylate monomers which are bifunctional and liquid crystalline will find suitable application in the present invention.

Referring now to FIG. 1 of the drawings, there is shown a cross-sectional view of an electrically switchable hologram 10 made of

an exposed polymer-dispersed liquid crystal material according to the teachings of the present invention. A layer 12 of the polymer-dispersed liquid crystal material is sandwiched between a pair of indium-tin-oxide (ITO) coated glass slides 14 and spacers 16. The interior of hologram 10 shows the Bragg transmission gratings 18 formed when layer 12 was exposed to an interference pattern from two intersecting beams of coherent laser light. The exposure times and intensities can be varied depending on the diffraction efficiency and liquid crystal domain size desired. Liquid crystal domain size can be controlled by varying the concentrations of photoinitiator, coinitiator and chain-extending (or cross-linking) agent. The orientation of the nematic directors can be controlled while the gratings are being recorded by application of an external electric field across the ITO electrodes.

The scanning electron micrograph shown in FIG. 2 of the referenced *Applied Physics Letters* article and incorporated herein by reference is of the surface of a grating which was recorded in a sample with a 36 wt% loading of liquid crystal using the 488 nm line of an argon ion laser at an intensity of 95 mW/cm². The size of the liquid crystal domains is about 0.2 μm and the grating spacing is about 0.54 μm . This sample, which is approximately 20 μm thick, diffracts light in the Bragg regime.

FIG. 2 is a graph of the normalized net transmittance and normalized net diffraction efficiency of a hologram made according to the teachings of the present invention versus the root mean square voltage ("V_{rms}") applied across the hologram. $\Delta\eta$ is the change in first order Bragg diffraction efficiency. ΔT is the change in zero order transmittance. FIG. 2 shows that energy is transferred from the first order beam to the zero-order beam as the voltage is increased. There is a true minimum of the diffraction efficiency at approximately 225 V_{rms}. The peak diffraction efficiency can approach 100%, depending on the wavelength and polarization of the probe beam, by appropriate adjustment of the sample thickness. The minimum diffraction efficiency can be made to approach 0% by slight adjustment of the parameters of the PDLC material to force the refractive index of the cured polymer to be equal to the ordinary refractive index of the liquid crystal.

By increasing the frequency of the applied voltage, the switching voltage for minimum diffraction efficiency can be decreased significantly. This is illustrated in FIG. 3, which is a graph of both

the threshold rms voltage 20 and the complete switching rms voltage 22 needed for switching a hologram made according to the teachings of the present invention to minimum diffraction efficiency versus the frequency of the rms voltage. The threshold and complete switching rms voltages are reduced to 20 Vrms and 60 Vrms, respectively, at 10 kHz. Lower values are expected at even higher frequencies.

Smaller liquid crystal droplet sizes have the problem that it takes high switching voltages to switch their orientation. As described in the previous paragraph, using alternating current switching voltages at high frequencies helps reduce the needed switching voltage. As demonstrated in FIG. 4, another unique discovery of the present invention is that adding a surfactant (e.g., octanoic acid) to the prepolymer material in amounts of about 4%-6% by weight of the total mixture resulted in sample holograms with switching voltages near 50 Vrms at lower frequencies of 1-2 kHz. As shown in FIG. 5, it has also been found that the use of the surfactant with the associated reduction in droplet size, reduces the switching time of the PDLC materials. Thus, samples made with surfactant can be switched on the order of 25-44 microseconds. Without wishing to be bound by any theory, the surfactant is believed to reduce switching voltages by reducing the anchoring of the liquid crystals at the interface between liquid crystal and cured polymer.

Thermal control of diffraction efficiency is illustrated in FIG. 6. FIG. 6 is a graph of the normalized net transmittance and normalized net diffraction efficiency of a hologram made according to the teachings of the present invention versus temperature.

The polymer-dispersed liquid crystal materials described herein successfully demonstrate the utility for recording volume holograms of a particular composition for such polymer-dispersed liquid crystal systems. Although the disclosed polymer-dispersed liquid crystal systems are specialized, the present invention will find application in other areas where a fast curing polymer and a material that can be phase-separated from the polymer will find use.

As shown in FIG. 7, a PDLC reflection grating is prepared by placing several drops of the mixture of prepolymer material 112 on an indium-tin oxide ("ITO") coated glass slide 114a. A second indium-tin oxide ("ITO") coated slide 114b is then pressed against the first, thereby causing the prepolymer material 112 to fill the region between

the slides 114a and 114b. Preferably, the separation of the slides is maintained at approximately 20 μm by utilizing uniform spacers 118. Preparation, mixing and transfer of the prepolymer material is preferably done in the dark. Once assembled, a mirror 116 is placed
5 directly behind the glass plate 114b. The distance of the mirror from the sample is preferably substantially shorter than the coherence length of the laser. The PDLC material is preferably exposed to the 488 nm line of an argon-ion laser, expanded to fill the entire plane of the glass plate, with an intensity of approximately 0.1-100
10 mWatts/cm² with typical exposure times of 30-120 seconds. Constructive and destructive interference within the expanded beam establishes a periodic intensity profile through the thickness of the film.

In the preferred embodiment, the prepolymer material utilized to make a reflection grating comprises a monomer, a liquid
15 crystal, a cross-linking monomer, a cointiator, and a photoinitiator dye. In the preferred embodiment, the reflection grating is formed from prepolymer material comprising by total weight of the monomer dipentaerythritol hydroxypentacrylate ("DPHA"), 34% by total weight of a liquid crystal comprising a mixture of cyano biphenyls (known
20 commercially as "E7"), 10% by total weight of a cross-linking monomer comprising N-vinylpyrrolidone ("NVP"), 2.5% by weight of the cointiator N-phenylglycine ("NPG"), and 10^{-5} to 10^{-6} gram moles of a photoinitiator dye comprising rose bengal ester. Further, as with transmission gratings, the addition of surfactants is expected to
25 facilitate the same advantageous properties discussed above in connection with transmission gratings. It is also expected that similar ranges and variation of prepolymer starting materials will find ready application in the formation of suitable reflection gratings.

It has been determined by low voltage, high resolution
30 scanning electron microscopy ("LVHRSEM") that the resulting material comprises a fine grating with a periodicity of 165 nm with the grating vector perpendicular to the plane of the surface. Thus, as shown schematically in FIG. 8a, grating 130 includes periodic planes of polymer channels 130a and PDLC channels 130b which run parallel to the
35 front surface 134. The grating spacing associated with these periodic planes remains relatively constant throughout the full thickness of the sample from the air/film to the film/substrate interface.

Although interference is used to prepare both transmission and reflection gratings, the morphology of the reflection grating

differs significantly. In particular, it has been determined that, unlike transmission gratings with similar liquid crystal concentrations, very little coalescence of individual droplets was evident. Furthermore, the droplets that were present in the material were significantly smaller, having diameters between 50 and 100 nm. Furthermore, unlike transmission gratings where the liquid crystal-rich regions typically comprise less than 40% of the grating, the liquid crystal-rich component of a reflection grating is significantly larger. Due to the much smaller periodicity associated with reflection gratings, i.e., a narrower grating spacing (~0.2 microns), it is believed that the time difference between completion of curing in high intensity versus low intensity regions is much smaller. Thus, gelation occurs more quickly and droplet growth is minimized. It is also believed that the fast polymerization, as evidenced by small droplet diameters, traps a significant percentage of the liquid crystal in the matrix during gelation and precludes any substantial growth of large droplets or diffusion of small droplets into larger domains.

Analysis of the reflection notch in the absorbance spectrum supports the conclusion that a periodic refractive index modulation is disposed through the thickness of the film. In PDLC materials that are formed with the 488nm line of an argon ion laser, the reflection notch typically has a reflection wavelength at approximately 472 nm for normal incidence and a relatively narrow bandwidth. The small difference between the writing wavelength and the reflection wavelength (approximately 5%) indicates that shrinkage of the film is not a significant problem. Moreover, it has been found that the performance of such gratings is stable over periods of many months.

In addition to the materials utilized in the preferred embodiment described above, it is believed that suitable PDLC materials could be prepared utilizing monomers such as triethyleneglycol diacrylate, trimethylolpropanetriacrylate, pentaerythritol triacrylate, pentaerythritol tetracrylate, pentaerythritol pentacrylate, and the like. Similarly, other cointiators such as triethylamine, triethanolamine, N,N-dimethyl-2,6-diisopropylaniline, and the like could be used instead of N-phenyl glycine. Where it is desirable to use the 458 nm, 476 nm, 488 nm or 514 nm lines of an Argon Ion laser, that the photoinitiator dyes rose bengal sodium salt, eosin, eosin sodium salt, fluorescein sodium salt and the like will give favorable results. Where the 633 nm line is utilized, methylene blue will find ready application. Finally, it is believed that other liquid crystals,

such as 4'-pentyl-4-cyanobiphenyl or 4'-heptyl-4-cyanobiphenyl, can be utilized in accordance with the invention.

Referring again to FIG. 8a, there is shown an elevational view of a reflection grating 130 in accordance with the invention having periodic planes of polymer channels 130a and PDLC channels 130b disposed parallel to the front surface 134 of the grating 130. The symmetry axis 136 of the liquid crystal domains is formed in a direction perpendicular to the periodic channels 130a and 130b of the grating 130 and perpendicular to the front surface 134 of the grating 130. Thus, when an electric field E is applied, as shown in FIG. 8b, the symmetry axis 136 is already in a low energy state in alignment with the field E and will not reorient. Thus, reflection gratings formed in accordance with the procedure described above will not normally be switchable.

In general, a reflection grating tends to reflect a narrow wavelength band, such that the grating can be used as a reflection filter. In the preferred embodiment, however, the reflection grating is formed so that it will be switchable. In accordance with the present invention, switchable reflection gratings can be made utilizing negative dielectric anisotropy LCs (or LCs with a low cross-over frequency), an applied magnetic field, an applied shear stress field, or slanted gratings.

It is known that liquid crystals having a negative dielectric anisotropy ($\Delta\epsilon$) will rotate in a direction perpendicular to an applied field. As shown in FIG. 9a, the symmetry axis 136 of the liquid crystal domains formed with a liquid crystal having a negative $\Delta\epsilon$ will also be disposed in a direction perpendicular to the periodic channels 130a and 130b of the grating 130 and to the front surface 134 of the grating. However, when an electric field E is applied across such gratings, as shown in FIG. 9b, the symmetry axis of the negative $\Delta\epsilon$ liquid crystal will distort and reorient in a direction perpendicular to the field E , which is perpendicular to the film and the periodic planes of the grating. As a result, the reflection grating can be switched between a state where it is reflective and a state where it is transmissive. The following negative $\Delta\epsilon$ liquid crystals and others are expected to find ready application in the methods and devices of the present invention:

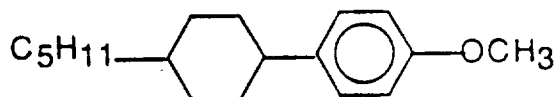
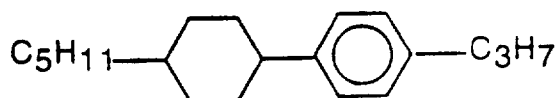
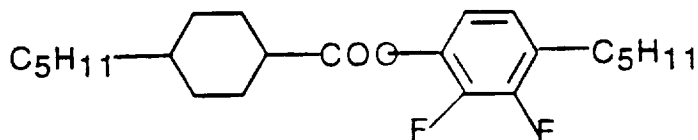
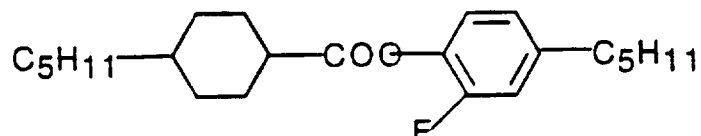
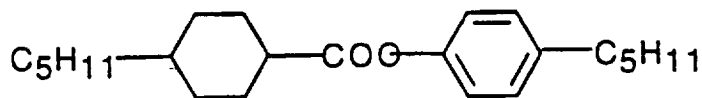

Liquid crystals can be found in nature (or synthesized) with either positive or negative $\Delta\epsilon$. Thus, in more detailed aspects of the invention, it is possible to use a LC which has a positive $\Delta\epsilon$ at low frequencies, but becomes negative at high frequencies. The frequency (of the applied voltage) at which $\Delta\epsilon$ changes sign is called the cross-over frequency. The cross-over frequency will vary with LC composition, and typical values range from 1-10 kHz. Thus, by operating at the proper frequency, the reflection grating may be switched. In accordance with the invention, it is expected that low crossover frequency materials can be prepared from a combination of positive and negative dielectric anisotropy liquid crystals. A suitable positive dielectric liquid crystal for use in such a combination contains four ring esters as shown below:

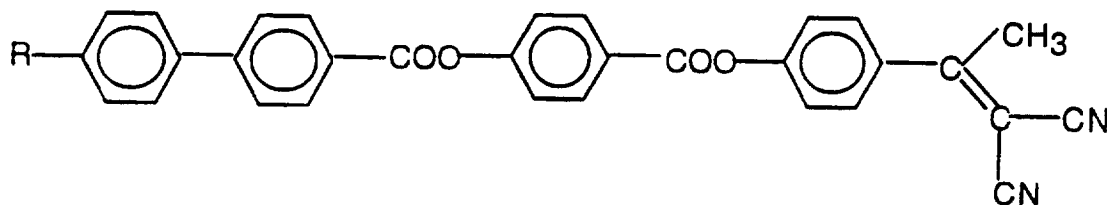

A strongly negative dielectric liquid crystal suitable for use in such a combination is made up of pyridazines as shown below:

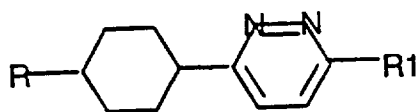

Both liquid crystal materials are available from LaRoche & Co., Switzerzlerland. By varying the proportion of the positive and negative liquid crystals in the combination, crossover frequencies from 1.4-2.3 kHz are obtained at room temperature. Another combination suitable for use in the present embodiment is a combination of the following:

5 p-pentylphenyl-2-chloro-4-(p-pentylbenzoyloxy) benzoate and benzoate.

10 These materials are available from Kodak Company.

In still more detailed aspects of the invention, switchable reflection gratings can be formed using positive $\Delta\epsilon$ liquid crystals. As shown in FIG. 10a, such gratings are formed by exposing the PDLC starting material to a magnetic field during the curing process. The magnetic field can be generated by the use of Helmholtz coils (as shown in FIG. 10a), the use of a permanent magnet, or other suitable means. Preferably, the magnetic field \mathbf{M} is oriented parallel to the front surface of the glass plates (not shown) that are used to form the grating 140. As a result, the symmetry axis 146 of the liquid crystals will orient along the field while the mixture is fluid. When polymerization is complete, the field may be removed and the alignment of the symmetry axis of the liquid crystals will remain unchanged. (See FIG. 10b.) When an electric field is applied, as shown in FIG. 10c, the positive $\Delta\epsilon$ liquid crystal will reorient in the direction of the field, which is perpendicular to the front surface of grating and to the periodic channels of the grating.

FIG. 11a depicts a slanted transmission grating 148 and FIG. 11b depicts a slanted reflection grating 150. A holographic transmission grating is considered slanted if the direction of the grating vector \mathbf{G} is not parallel to the grating surface. In a holographic reflection grating, the grating is said to be slanted if the grating vector \mathbf{G} is not perpendicular to the grating surface. Slanted gratings have many of the same uses as nonslanted gratings such as visual displays, mirrors, line filters, optical switches, and the like.

Primarily, slanted holographic gratings are used to control the direction of a diffracted beam. For example, in reflection holograms a slanted grating is used to separate the specular reflection of the film from the diffracted beam. In a PDLC holographic grating, a slanted grating has an even more useful advantage. The slant allows the modulation depth of the grating to be controlled by an electric field when using either tangential or homeotropic aligned liquid crystals. This is because the slant provides components of the electric field in the directions both tangent and perpendicular to the grating vector. In particular, for the reflection grating, the LC domain symmetry axis will be oriented along the grating vector \mathbf{G} and can be switched to a direction perpendicular to the film plane by a longitudinally applied field \mathbf{E} . This is the typical geometry for switching of the diffraction efficiency of a slanted reflection grating.

When recording slanted reflection gratings, it is desirable to place the sample between the hypotenuses of two right-angle glass prisms. Neutral density filters can then be placed in optical contact with the back faces of the prisms using index matching fluids so as to frustrate back reflections which would cause spurious gratings to also be recorded. The incident laser beam is split by a conventional beam splitter into two beams which are then directed to the front faces of the prisms, and then overlapped in the sample at the desired angle. The beams thus enter the sample from opposite sides. This prism coupling technique permits the light to enter the sample at greater angles. The slant of the resulting grating is determined by the angle which the prism assembly is rotated (i.e., the angle between the direction of one incident beam and the normal to the prism front face at which that beam enters the prism).

As shown in FIG. 12, switchable reflection gratings may be formed in the presence of by an applied shear stress field. In this method, a shear stress would be applied along the direction of a magnetic field M . This could be accomplished, for example, by applying equal and opposite tensions to the two ITO coated glass plates which sandwich the prepolymer mixture while the polymer is still soft. This shear stress would distort the LC domains in the direction of the stress, and the resultant LC domain symmetry axis will be preferentially along the direction of the stress, parallel to the PDLC planes and perpendicular to the direction of the applied electric field for switching.

Reflection gratings prepared in accordance with the teachings of the present invention will find application in color reflective displays, switchable wavelength filters for laser protection, and the like.

In another embodiment of the present invention, PDLC materials can be made that exhibit a property known as form birefringence whereby polarized light that is transmitted through the grating will have its polarization modified. Such gratings are known as subwavelength gratings, and they behave like a negative uniaxial crystal, such as calcite, potassium dihydrogen phosphate, or lithium niobate, with an optic axis perpendicular to the PDLC planes. Referring now to FIG. 13, there is shown an elevational view of a transmission grating 200 in accordance with the present invention having periodic planes of polymer planes 200a and PDLC planes 200b disposed

perpendicular to the front surface 204 of the grating 200. The optic axis 206 is disposed perpendicular to polymer planes 200a and the PDLC planes 200b. Each polymer plane 200a has a thickness t_p and refractive index n_p , and each PDLC plane 200b has a thickness $t_{\text{PDL C}}$ and refractive index $n_{\text{PDL C}}$.

Where the combined thickness of the PDLC plane and the polymer plane is substantially less than an optical wavelength (i.e. $(t_{\text{PDL C}} + t_p) \ll \lambda$), the grating will exhibit form birefringence. As discussed below, the magnitude of the shift in polarization is proportional to the length of the grating. Thus, by carefully selecting the length, L , of the subwavelength grating for a given wavelength of light, one can rotate the plane of polarization or create circularly polarized light. Consequently, such subwavelength gratings can be designed to act as a half-wave or quarter-wave plate, respectively. Thus, an advantage of this process is that the birefringence of the material may be controlled by simple design parameters and optimized to a particular wavelength, rather than relying on the given birefringence of any material at that wavelength.

To form a half-wave plate, the retardance of the subwavelength grating must be equal to one-half of a wavelength, i.e. retardance = $\lambda/2$, and to form a quarter-wave plate, the retardance must be equal to one-quarter of a wavelength, i.e. retardance = $\lambda/4$. It is known that the retardance is related to the net birefringence, $|\Delta n|$, which is the difference between the ordinary index of refraction, n_o , and the extraordinary index of refraction n_e , of the sub-wavelength grating by the following relation:

$$\text{Retardance} = |\Delta n|L = |n_e - n_o|L$$

Thus, for a half-wave plate, i.e. a retardance equal to one-half of a wavelength, the length of the subwavelength grating should be selected so that:

$$L = \lambda / (2|\Delta n|)$$

Similarly, for a quarter-wave plate, i.e. a retardance equal to one-quarter of a wavelength, the length of the subwavelength grating should be selected so that:

$$L = \lambda / (4|\Delta n|)$$

If, for example, the polarization of the incident light is at an angle of 45° with respect to the optic axis 210 of a half-wave plate 212, as shown in FIG. 14a, the plane polarization will be preserved, but the polarization of the wave exiting the plate will be shifted by 90°. Thus, referring now to FIG. 14b and 14c, where the half-wave plate 212 is placed between cross polarizers 214 and 216, the incident light will be transmitted. If an appropriate switching voltage is applied, as shown in FIG. 14d, the polarization of the light is not rotated and the light will be blocked by the second polarizer.

For a quarter wave plate plane polarized light is converted to circularly polarized light. Thus, referring now to FIG. 15a, where quarter wave plate 217 is placed between a polarizing beam splitter 218 and a mirror 219, the reflected light will be reflected by the beam splitter 218. If an appropriate switching voltage is applied, as shown in FIG. 15b, the reflected light will pass through the beam splitter and be retroreflected on the incident beam.

Referring now to FIG. 16a, there is shown an elevational view of a subwavelength grating 230 recorded in accordance with the above-described methods and having periodic planes of polymer channels 230a and PDLC channels 230b disposed perpendicular to the front surface 234 of grating 230. As shown FIG. 16a, the symmetry axis 232 of the liquid crystal domains is disposed in a direction parallel to the front surface 234 of the grating and perpendicular to the periodic channels 230a and b of the grating 230. Thus, when an electric field **E** is applied across the grating, as shown in FIG. 15b, the symmetry axis 232 distorts and reorients in a direction along the field **E**, which is perpendicular to the front surface 234 of the grating and parallel to the periodic channels 230a and 230b of the grating 230. As a result, subwavelength grating 230 can be switched between a state where it changes the polarization of the incident

radiation and a state in which it does not. Without wishing to be bound by any theory, it is currently believed that the direction of the liquid crystal domain symmetry **232** is due to a surface tension gradient which occurs as a result of the anisotropic diffusion of monomer and liquid crystal during recording of the grating and that this gradient causes the liquid crystal domain symmetry to orient in a direction perpendicular to the periodic planes.

As discussed is Born and Wolf, Principles of Optics, 5th Ed., New York (1975) and incorporated herein by reference, the birefringence of a subwavelength grating is given by the following relation:

$$n_e^2 - n_o^2 = -\frac{[f_{\text{PDLC}}(f_p)(n_{\text{PDLC}}^2 - n_p^2)]}{[f_{\text{PDLC}}n_{\text{PDLC}}^2 + f_p n_p^2]}$$

where

n_o = the ordinary index of refraction of the subwavelength grating;

n_e = the extraordinary index of refraction;

n_{PDLC} = the refractive index of the PDLC plane;

n_p = the refractive index of the polymer plane;

n_{LC} = the effective refractive index of the liquid crystal seen by an incident optical wave;

f_{PDLC} = $t_{\text{PDLC}} / (t_{\text{PDLC}} + t_p)$

f_p = $t_p / (t_{\text{PDLC}} + t_p)$

Thus, the net birefringence of the subwavelength grating will be zero if $n_{\text{PDLC}} = n_p$.

It is known that the effective refractive index of the liquid crystal, n_{LC} , is a function of the applied electric field, having a maximum when the field is zero and a value equal to that of the polymer, n_p , at some value of the electric field, E_{MAX} . Thus, by application of an electric field, the refractive index

of the liquid crystal, n_{LC} , and, hence, the refractive index of the PDLC plane can be altered. Using the relationship set forth above, the net birefringence of a subwavelength grating will be a minimum when n_{PDLC} is equal to n_p , i.e. when $n_{LC} = n_p$. Therefore, if the refractive index of the PDLC plane can be matched to the refractive index of the polymer plane, i.e. $n_{PDLC} = n_p$, by the application of an electric field, the birefringence of the subwavelength grating can be switched off.

The following equation for net birefringence, i.e. $|\Delta n| = |n_e - n_o|$, follows from the equation given in Born and Wolf (reproduced above):

$$\Delta n = -\frac{[(f_{PDLC})(f_p)(n_{PDLC}^2 - n_p^2)]}{[2n_{AVG}(f_{PDLC}n_{PDLC}^2 + f_p n_p^2)]}$$

$$\text{where } n_{AVG} = (n_e + n_o)/2$$

Furthermore, it is known that the refractive index of the PDLC plane n_{PDLC} is related to the effective refractive index of the liquid crystal seen by an incident optical wave, n_{LC} , and the refractive index of the surrounding polymer plane, n_p , by the following relation:

$$n_{PDLC} = n_p + f_{LC}[n_{LC} - n_p]$$

where f_{LC} is the volume fraction of liquid crystal dispersed in the polymer within the PDLC plane, $f_{LC} = [V_{LC}/(V_{LC} + V_p)]$.

By way of example, a typical value for the effective refractive index for the liquid crystal in the absence of an electric field is $n_{LC} = 1.7$, and for the polymer layer $n_p = 1.5$. For a grating where the thickness of the PDLC planes and the polymer planes are equal (i.e. $t_{PDLC} = t_p$, $f_{PDLC} = 0.5 = f_p$) and $f_{LC} = 0.35$, the net birefringence, Δn , of the subwavelength grating is approximately 0.008. Thus, where the incident light has a wavelength of $0.8\mu\text{m}$, the length of the subwavelength grating

should be $50\mu\text{m}$ for a half-wave plate and $25\mu\text{m}$ for a quarter-wave plate. Furthermore, by application of an electric field of approximately $5\text{ V}/\mu\text{m}$, the refractive index of the liquid crystal can be matched to the refractive index of the polymer and the birefringence of the subwavelength grating turned off. Thus, the switching voltage, V_n , for a half-wave plate is on the order of 250 volts, and for a quarter-wave plate approximately 125 volts.

By applying such voltages, the plates can be switched between the on and off (zero retardance) states on the order of microseconds. As a means of comparison, current Pockels cell technology can be switched in nanoseconds with voltages of approximately 1000-2000 volts, and bulk nematic liquid crystals can be switched on the order of milliseconds with voltages of approximately 5 volts.

In an alternative embodiment of the invention shown in FIG. 17, the switching voltage of the subwavelength grating can be reduced by stacking several subwavelength gratings **220a-e** together, and connecting them electrically in parallel. By way of example, it has been found that a stack of five gratings each with a length of $10\mu\text{m}$ yields the thickness required for a half-wave plate. It should be noted that the length of the sample is somewhat greater than $50\mu\text{m}$, because each grating includes an indium-tin-oxide coating which acts as a transparent electrode. The switching voltage for such a stack of plates, however, is only 50 volts.

Subwavelength gratings in accordance with the present invention are expected to find suitable application in the areas of polarization optics and optical switches for displays and laser optics, as well as tunable filters for telecommunications, colorimetry, spectroscopy, laser protection, and the like. Similarly, electrically switchable transmission gratings have many applications for which beams of light must be deflected or holographic images switched. Among these applications are: Fiber optic switches, reprogrammable NxN optical interconnects for optical computing, beam steering for laser surgery, beam

steering for laser radar, holographic image storage and retrieval, digital zoom optics (switchable holographic lenses), graphic arts and entertainment, and the like.

5 A switchable hologram is one for which the diffraction efficiency of the hologram may be modulated by the application of an electric field, and can be switched from a fully on state (high diffraction efficiency) to a fully off state (low or zero diffraction efficiency). A static hologram is one whose properties remain fixed independent of an applied field. In
10 accordance with the present invention, a high contrast static hologram can also be created. In this variation of the present invention, the holograms are recorded as described previously. The cured polymer film is then soaked in a suitable solvent at room temperature for a short duration and finally dried. For the
15 liquid crystal E7, methanol has shown satisfactory application. Other potential solvents include alcohols such as ethanol, hydrocarbons such as hexane and heptane, and the like. When the material is dried, a high contrast static hologram with high diffraction efficiency results. The high diffraction efficiency
20 is a consequence of the large index modulation in the film ($\Delta n \sim 0.5$) because the second phase domains are replaced with empty (air) voids ($n \sim 1$).

Similarly, in accordance with the present invention, a high birefringence static sub-wavelength wave-plate can also
25 be formed. Due to the fact that the refractive index for air is significantly lower than for most liquid crystals, the corresponding thickness of the half-wave plate would be reduced accordingly. Synthesized wave-plates in accordance with the present invention can be used in many applications employing
30 polarization optics, particularly where a material of the appropriate birefringence at the appropriate wavelength is unavailable, too costly, or too bulky.

In the claims, the term polymer-dispersed liquid crystals and polymer-dispersed liquid crystal material includes,
35 as may be appropriate, solutions in which none of the monomers

have yet polymerized or cured, solutions in which some polymerization has occurred, and solutions which have undergone complete polymerization. Those of skill in the art in the field of the invention will clearly understand that the use herein of the standard term used in the art, polymer-dispersed liquid crystals (which grammatically refers to liquid crystals dispersed in a fully polymerized matrix) is meant to include all or part of a more grammatically correct prepolymer-dispersed liquid crystal material or a more grammatically correct starting material for a polymer-dispersed liquid crystal material.

It will be seen that modifications to the invention as described may be made, as might occur to one with skill in the field of the invention, within the intended scope of the claims. Therefore, all embodiments contemplated have not been shown in complete detail. Other embodiments may be developed without departing from the spirit of the invention or from the scope of the claims.

CLAIMS

1. A reflection hologram [grating] made by exposing an interference pattern inside a polymer-dispersed liquid crystal material, the polymer-dispersed liquid crystal material comprising, before exposure:

5 (a) a polymerizable monomer [comprising dipentarythritol hydroxypentaacrylate];

(b) a liquid crystal;

(c) a cross-linking monomer;

(d) a coinitiator; and

11 (e) a photoinitiator dye.

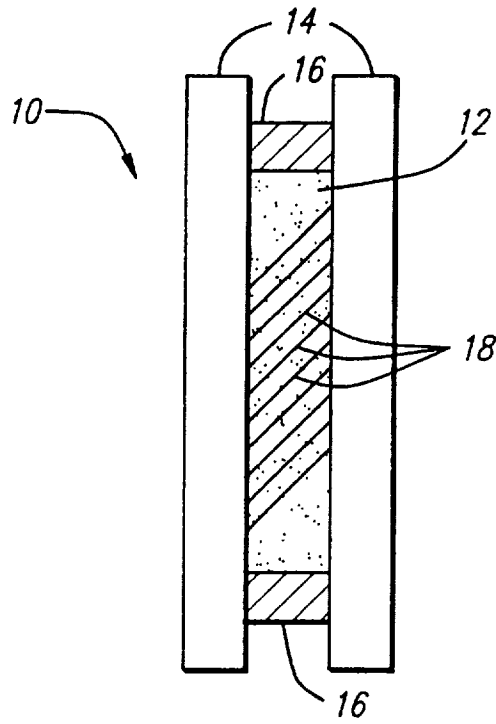

FIG. 1

2/13

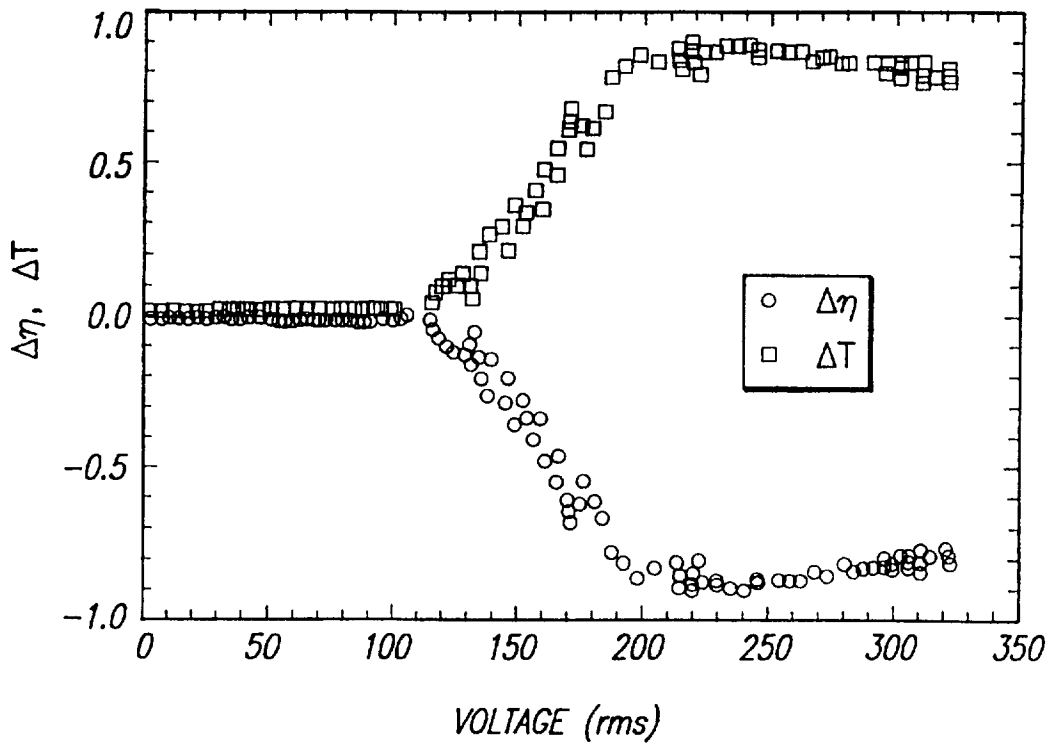

FIG. 2

FREQUENCY DEPENDENCE OF GRATING SWITCHING VOLTAGES

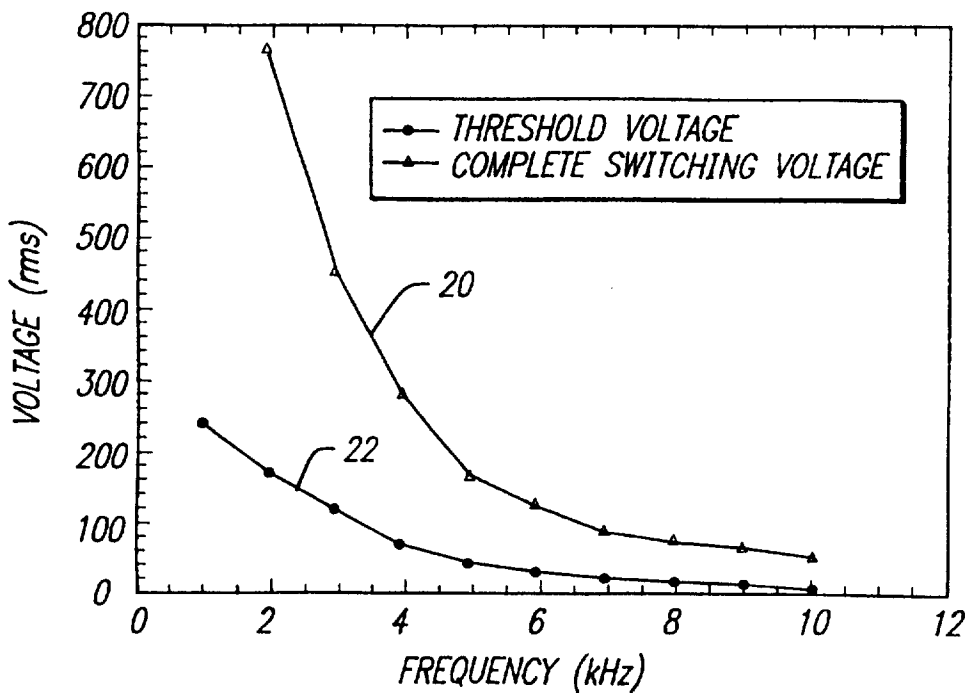

FIG. 3

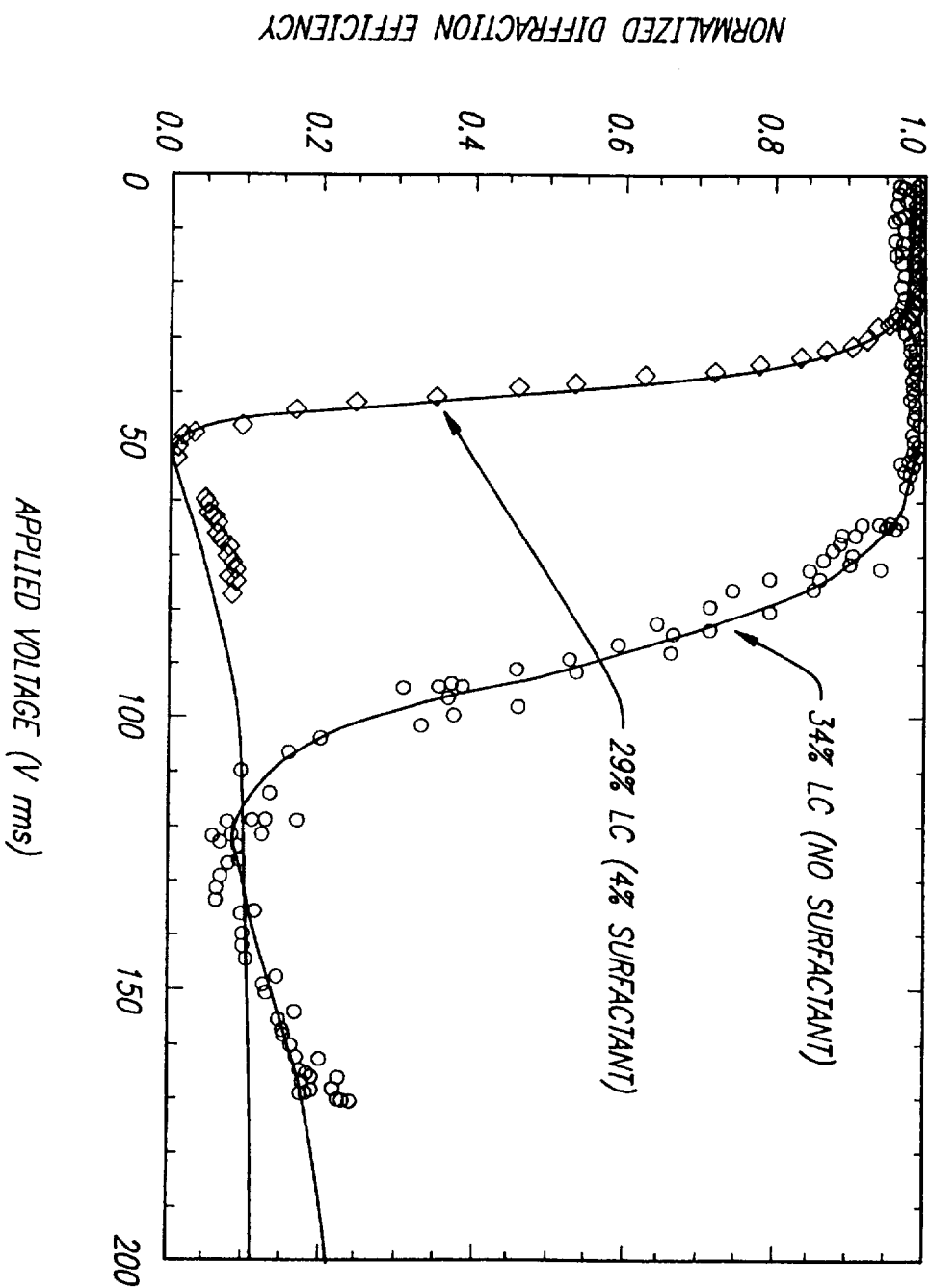

FIG. 4

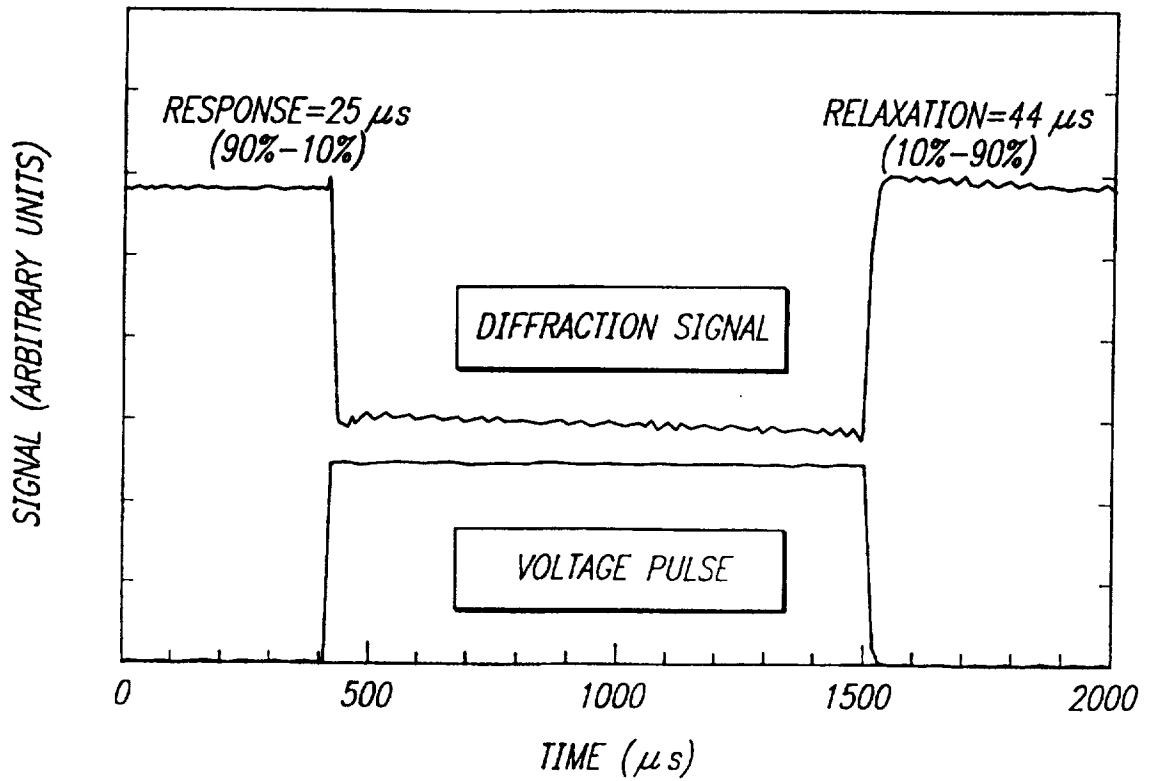

FIG. 5

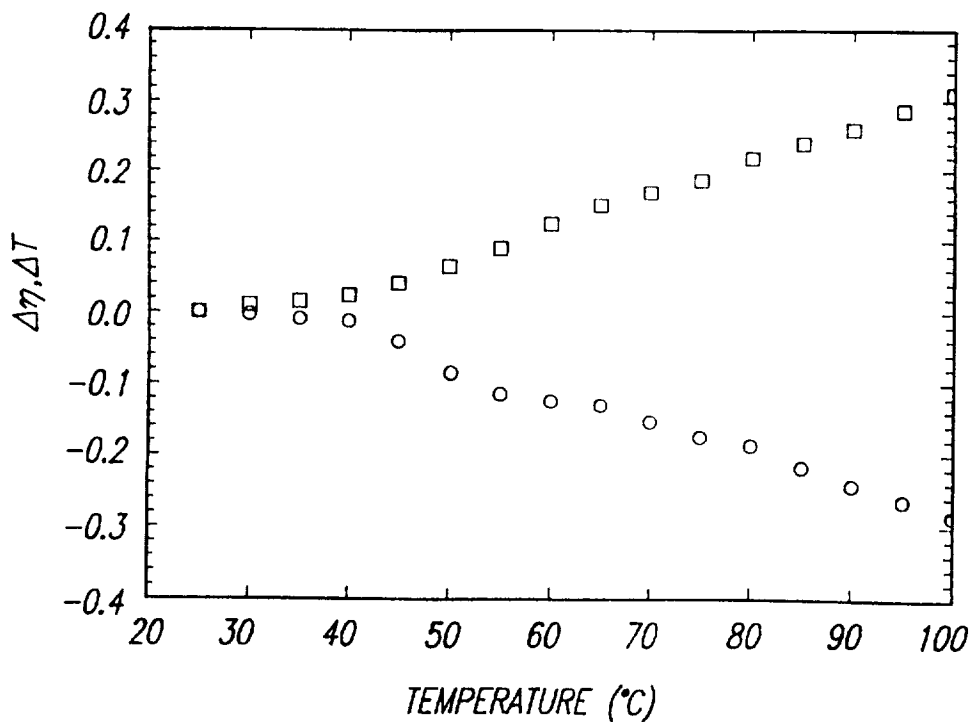

FIG. 6

SUBSTITUTE SHEET (RULE 26)

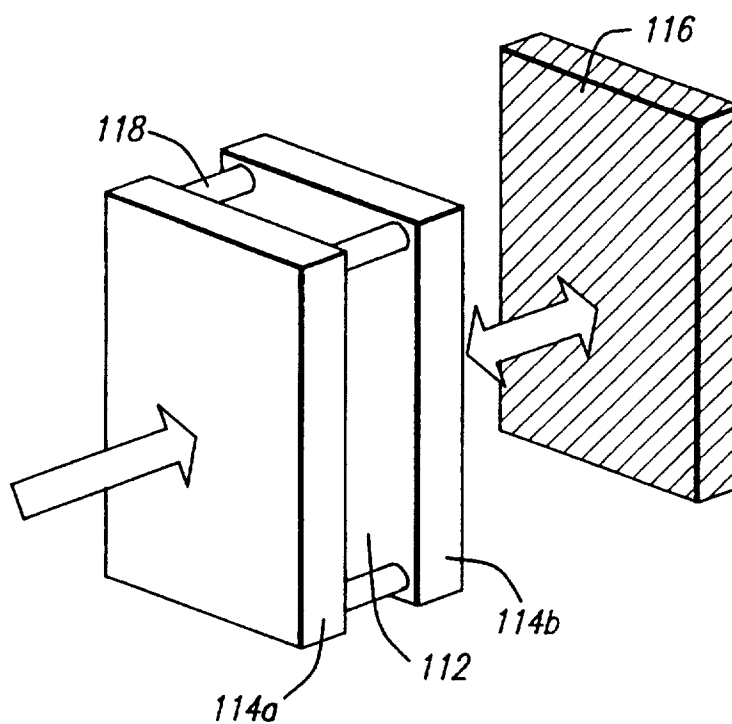

FIG. 7

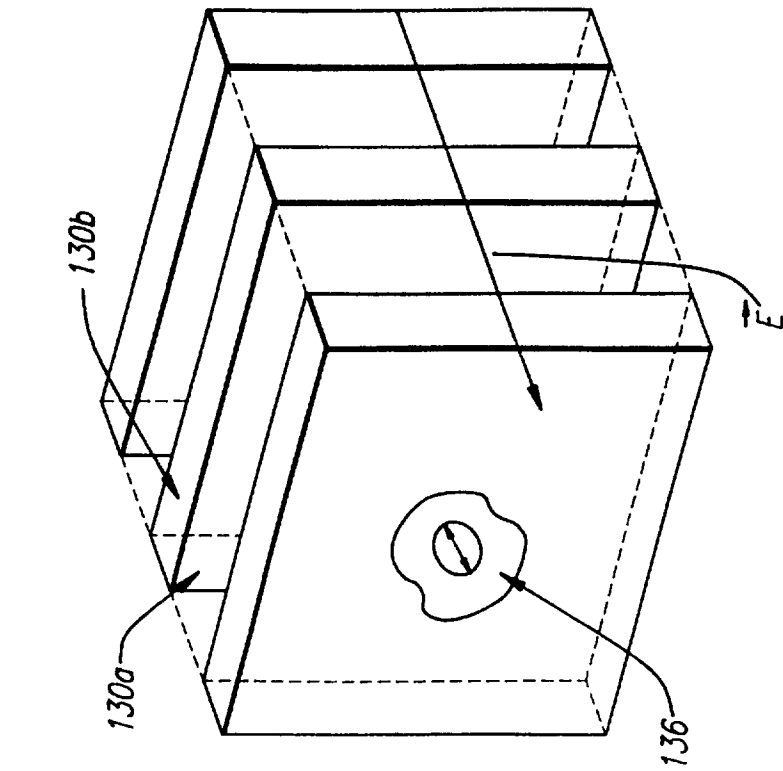

FIG. 8a

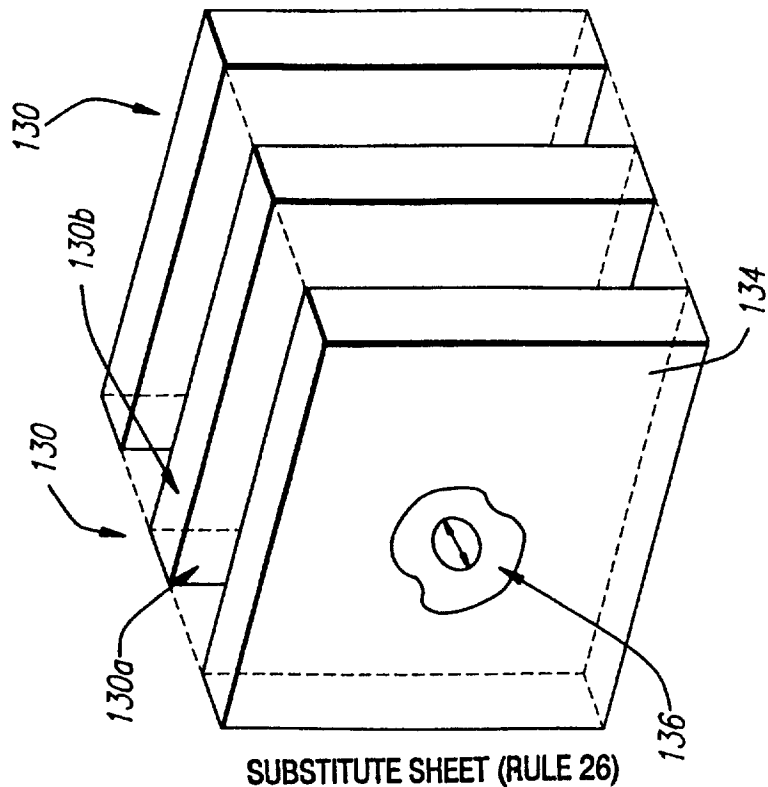

FIG. 8b

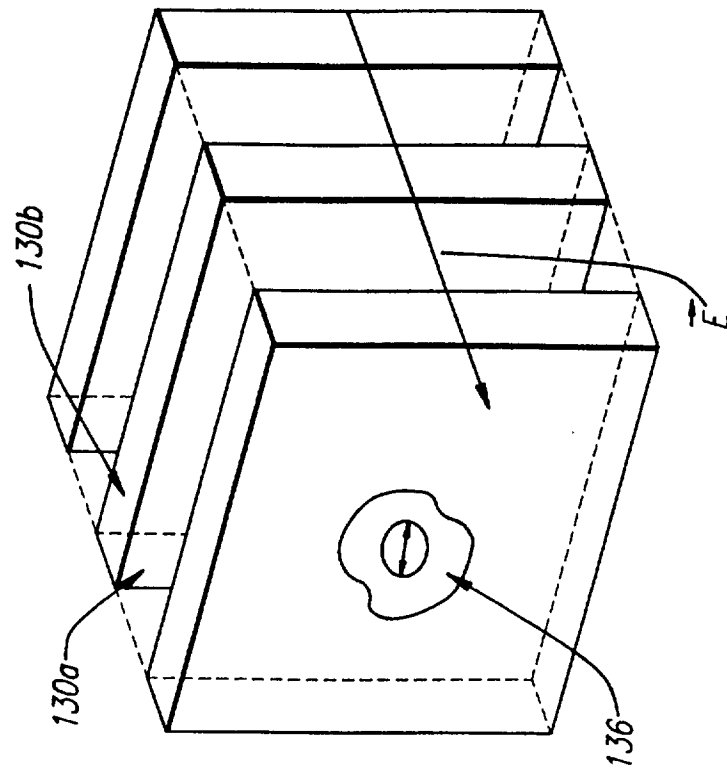

FIG. 9a

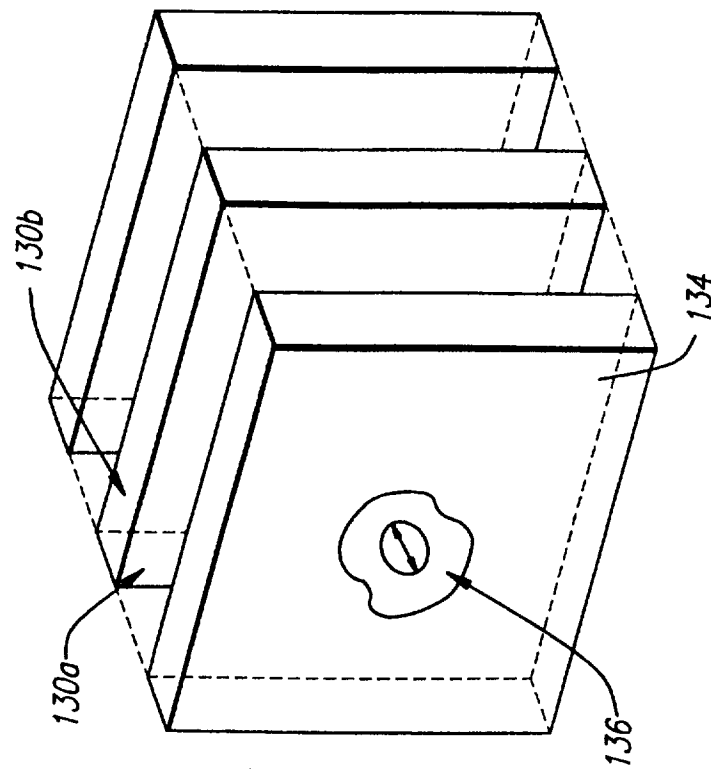

FIG. 9b

SUBSTITUTE SHEET (RULE 26)

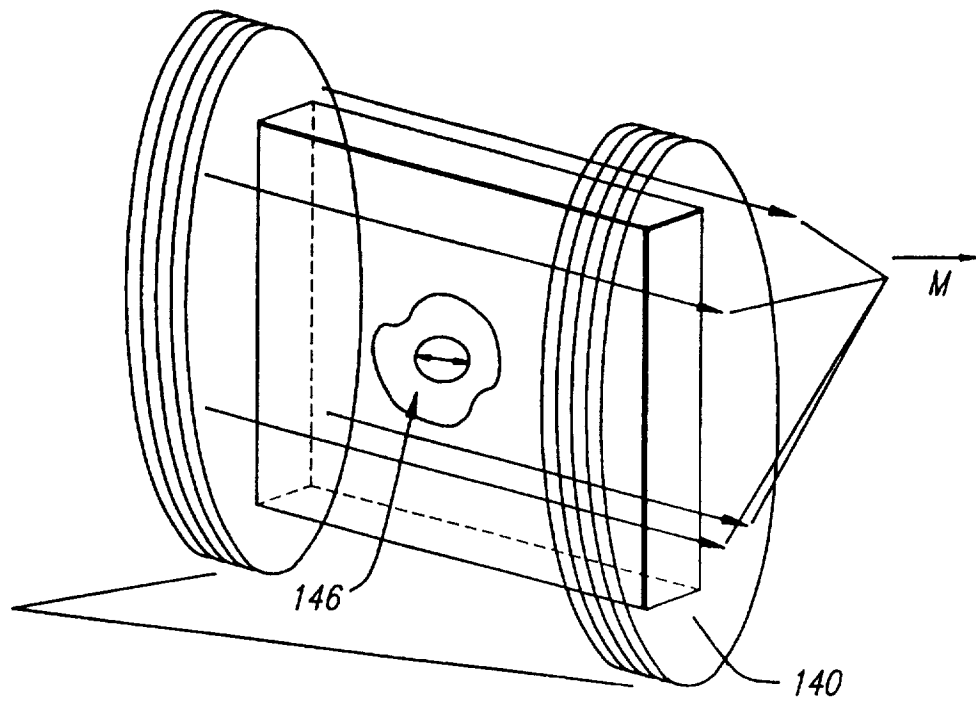

FIG. 10a

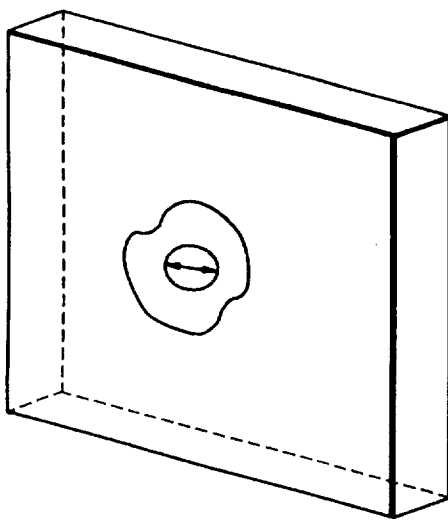

FIG. 10b

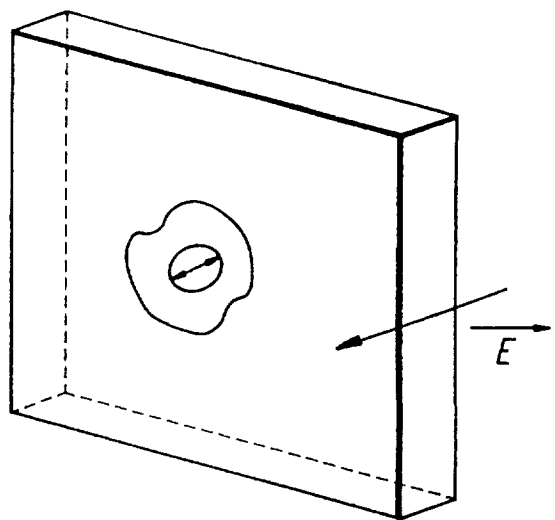
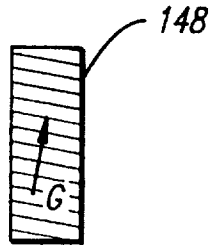
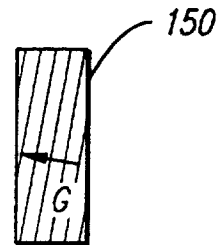

FIG. 10c



SLANTED
TRANSMISSION

FIG. 11a



SLANTED
REFLECTION

FIG. 11b

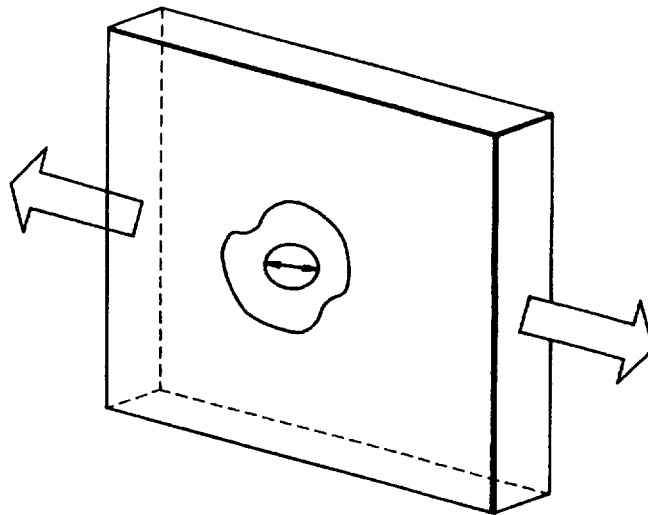

FIG. 12

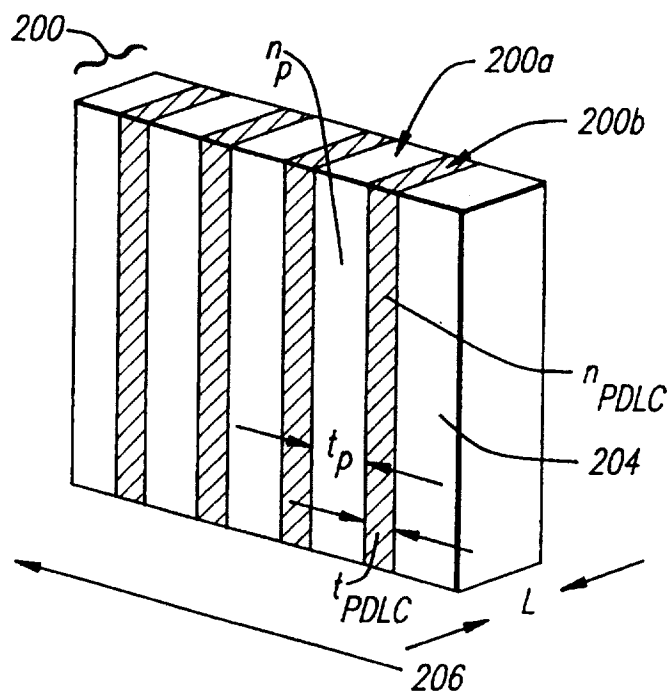

FIG. 13

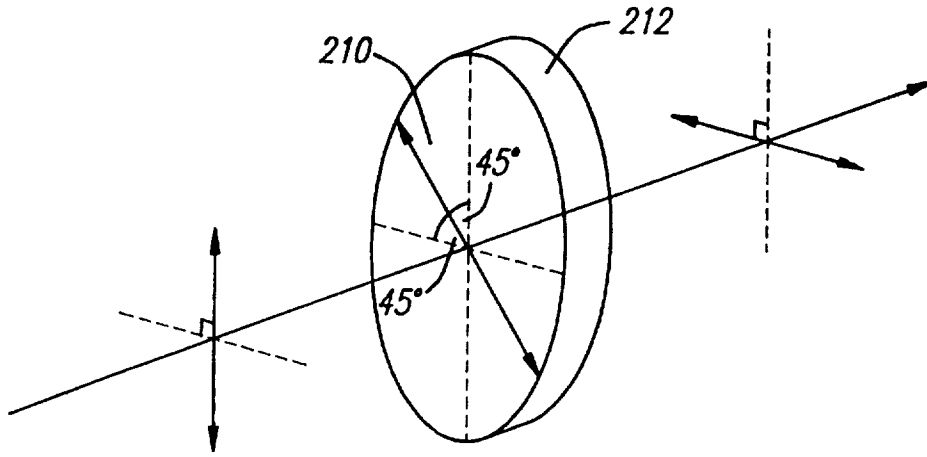

FIG. 14a

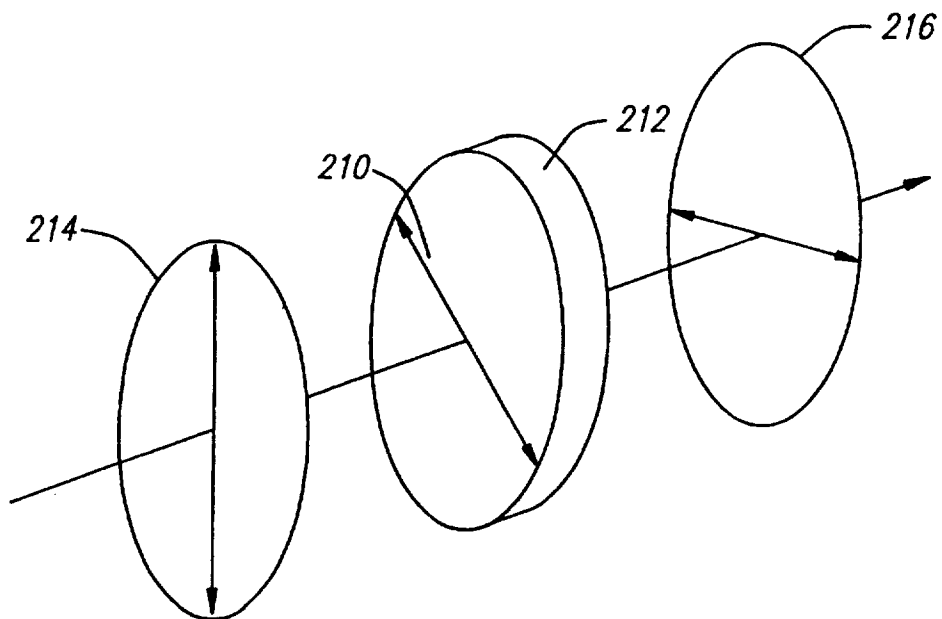
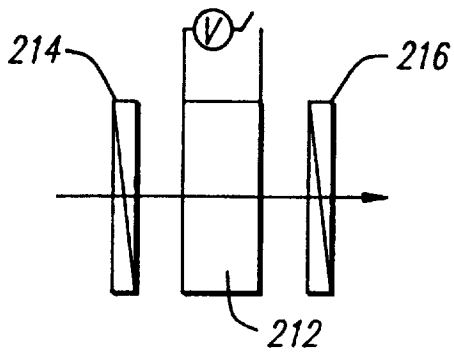
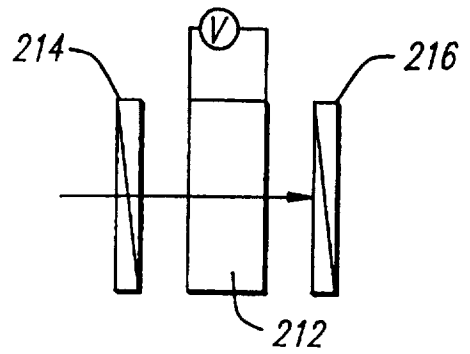

FIG. 14b



LIGHT TRANSMITTED

FIG. 14c



LIGHT BLOCKED

FIG. 14d

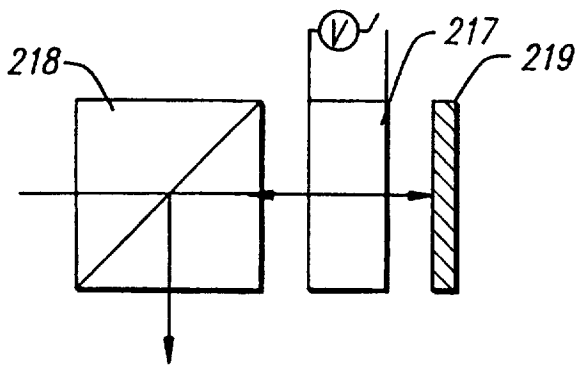

TRANSMITTED

FIG. 15a

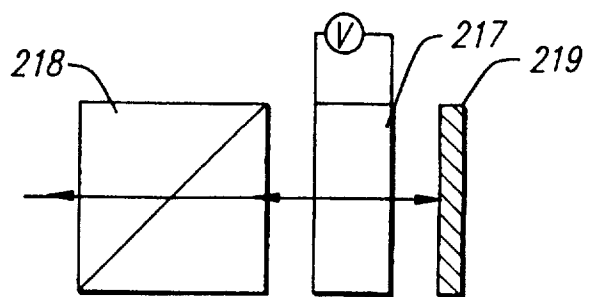

RETRO-REFLECTED

FIG. 15b

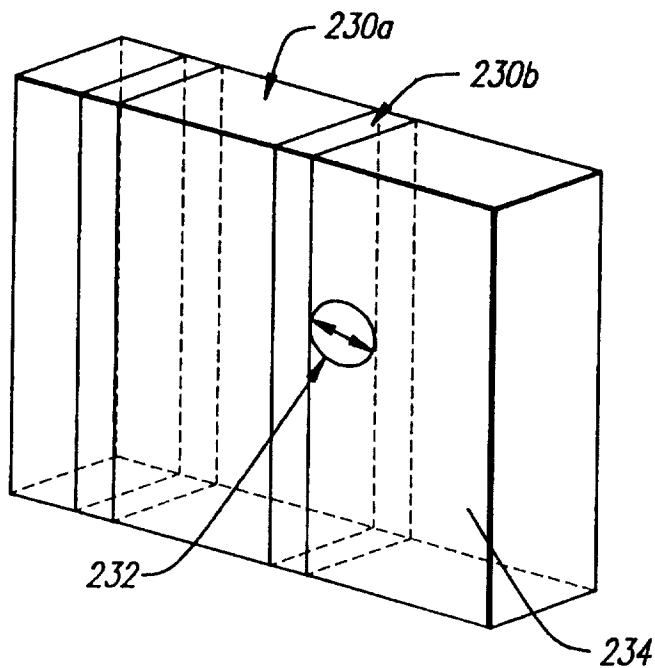

UNSWITCHED STATE

FIG. 16a

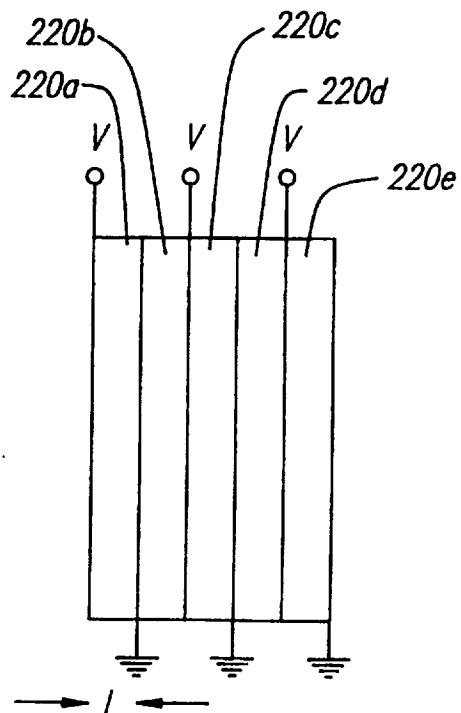
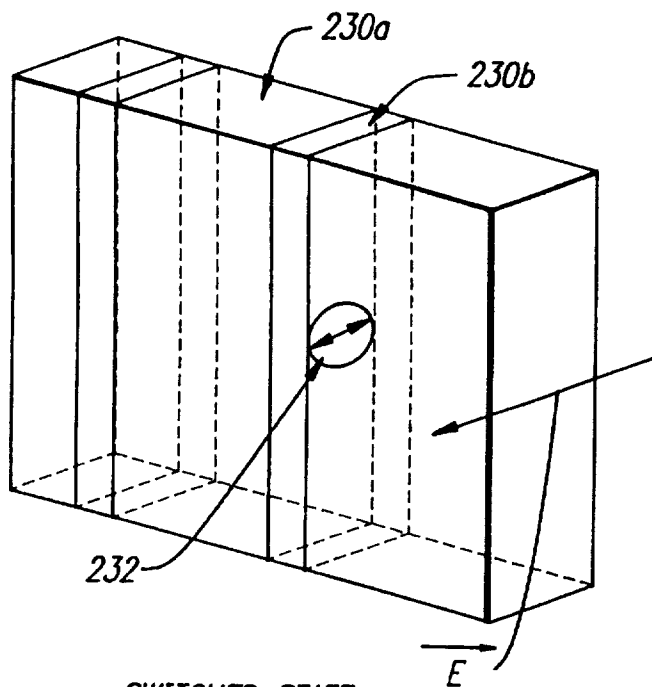

FIG. 17



SWITCHED STATE

FIG. 16b

INTERNATIONAL SEARCH REPORT

International application No.
PCT/US97/12577

A. CLASSIFICATION OF SUBJECT MATTER

IPC(6) :C09K 19/00; F21V 1/08; G03H 1/02
US CL :252/299.01, 582; 359/3

According to International Patent Classification (IPC) or to both national classification and IPC

B. FIELDS SEARCHED

Minimum documentation searched (classification system followed by classification symbols)

U.S. : 252/299.01, 582; 359/3

Documentation searched other than minimum documentation to the extent that such documents are included in the fields searched

Electronic data base consulted during the international search (name of data base and, where practicable, search terms used)

C. DOCUMENTS CONSIDERED TO BE RELEVANT

Category*	Citation of document, with indication, where appropriate, of the relevant passages	Relevant to claim No.
Y	US 5,096,282 A (MARGERUM et al.) 17 March 1992, columns 6, 11 and 12.	1
A	US 5,105,298 A (SCHELLENBERG) 14 April 1992, column 2.	1
A	US 5,011,624 A (YAMAGISHI et al.) 30 April 1991, column 3.	1
Y	US 4,688,900 A (DOANE et al.) 25 August 1987, column 12.	1
Y	US 4,938,568 A (MARGERUM et al.) 03 July 1990, column 6.	1
Y,P	US 5,328,800 A (YOKOYA et al.) 12 July 1994, column 3.	1

Further documents are listed in the continuation of Box C. See patent family annex.

* Special categories of cited documents:	*T* later document published after the international filing date or priority date and not in conflict with the application but cited to understand the principle or theory underlying the invention
A document defining the general state of the art which is not considered to be of particular relevance	*X* document of particular relevance; the claimed invention cannot be considered novel or cannot be considered to involve an inventive step when the document is taken alone
B earlier document published on or after the international filing date	*Y* document of particular relevance; the claimed invention cannot be considered to involve an inventive step when the document is combined with one or more other such documents, such combination being obvious to a person skilled in the art
L document which may throw doubts on priority claim(s) or which is cited to establish the publication date of another citation or other special reason (as specified)	*A* document member of the same patent family
O document referring to an oral disclosure, use, exhibition or other means	
P document published prior to the international filing date but later than the priority date claimed	

Date of the actual completion of the international search

22 SEPTEMBER 1997

Date of mailing of the international search report

14 JAN 1998

Name and mailing address of the ISA/US
Commissioner of Patents and Trademarks
Box PCT
Washington, D.C. 20231

Facsimile No. (703) 305-3230

Authorized officer

IW for
CYNTHIA HARRIS KELLY

Telephone No. (703) 308-1235

INTERNATIONAL SEARCH REPORT

International application No.
PCT/US97/12577

C (Continuation). DOCUMENTS CONSIDERED TO BE RELEVANT

Category*	Citation of document, with indication, where appropriate, of the relevant passages	Relevant to claim No.
A	CA 544,591 A (NATIONAL RESEARCH DEVELOPMENT CORPORATION) 06 August 1957, column 10.	1