

(19) World Intellectual Property Organization
International Bureau



(43) International Publication Date
12 September 2002 (12.09.2002)

PCT

(10) International Publication Number
WO 02/069818 A2

- (51) International Patent Classification⁷: **A61B 17/68**
- (21) International Application Number: PCT/US01/25455
- (22) International Filing Date: 14 August 2001 (14.08.2001)
- (25) Filing Language: English
- (26) Publication Language: English
- (30) Priority Data:

60/271,745	28 February 2001 (28.02.2001)	US
09/927,333	13 August 2001 (13.08.2001)	US
09/927,334	13 August 2001 (13.08.2001)	US
09/927,335	13 August 2001 (13.08.2001)	US
- (74) Agents: **POISSANT, Brian, M.** et al.; Pennie & Edmonds LLP, 1155 Avenue of the Americas, New York, NY 10036 (US).
- (81) Designated States (*national*): AE, AG, AL, AM, AT, AU, AZ, BA, BB, BG, BR, BY, BZ, CA, CH, CN, CO, CR, CU, CZ, DE, DK, DM, DZ, EC, EE, ES, FI, GB, GD, GE, GH, GM, HR, HU, ID, IL, IN, IS, JP, KE, KG, KP, KR, KZ, LC, LK, LR, LS, LT, LU, LV, MA, MD, MG, MK, MN, MW, MX, MZ, NO, NZ, PL, PT, RO, RU, SD, SE, SG, SI, SK, SL, TJ, TM, TR, TT, TZ, UA, UG, UZ, VN, YU, ZA, ZW.
- (84) Designated States (*regional*): ARIPO patent (GH, GM, KE, LS, MW, MZ, SD, SL, SZ, TZ, UG, ZW), Eurasian patent (AM, AZ, BY, KG, KZ, MD, RU, TJ, TM), European patent (AT, BE, CH, CY, DE, DK, ES, FI, FR, GB, GR, IE, IT, LU, MC, NL, PT, SE, TR), OAPI patent (BF, BJ, CF, CG, CI, CM, GA, GN, GQ, GW, ML, MR, NE, SN, TD, TG).

(71) Applicant: **SYNTHES (U.S.A.)** [US/US]; 1690 Russell Road, Paoli, PA 19301 (US).

(72) Inventors: **BOYER, Michael, L., II**; 1708 East Lancaster Avenue, Paoli, PA 19301 (US). **PAUL, David, C.**; 405 Greene Lane, Phoenixville, PA 19460 (US). **ANGELUCCI, Christopher, M.**; 809 Summit Avenue, Schwenksville, PA 19473 (US).

Published:

— without international search report and to be republished upon receipt of that report

For two-letter codes and other abbreviations, refer to the "Guidance Notes on Codes and Abbreviations" appearing at the beginning of each regular issue of the PCT Gazette.

(54) Title: DEMINERALIZED BONE-DERIVED IMPLANTS

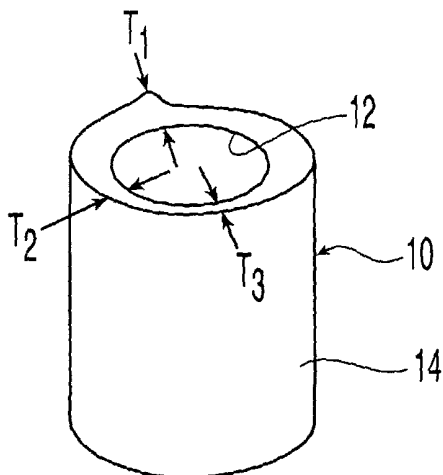

(57) Abstract: Selectively demineralized bone-derived implants are provided. In one embodiment, a bone sheet for implantation includes a demineralized field surrounding mineralized regions. In another embodiment, a bone defect filler includes a demineralized cancellous bone section in a first geometry. The first geometry is compressible and dryable to a second geometry smaller than the first geometry, and the second geometry is expandable and rehydratable to a third geometry larger than the second geometry.

WO 02/069818 A2

DEMINERALIZED BONE-DERIVED IMPLANTS

FIELD OF THE INVENTION

5 The invention is related to implants formed from bone. More particularly, the invention is related to implants formed from partially demineralized or demineralized bone.

BACKGROUND OF THE INVENTION

10 Bone grafts have become an important and accepted means for treating bone fractures and defects. In the United States alone, approximately half a million bone grafting procedures are performed annually, directed to a diverse array of medical interventions for complications such as fractures involving bone loss, injuries or other conditions necessitating immobilization by fusion (such as for the spine or joints), and other bone
15 defects that may be present due to trauma, infection, or disease. Bone grafting involves the surgical transplantation of pieces of bone within the body, and generally is effectuated through the use of graft material acquired from a human source. This is primarily due to the limited applicability of xenografts, transplants from another species.

 Orthopedic autografts or autogenous grafts involve source bone acquired
20 from the same individual that will receive the transplantation. Thus, this type of transplant moves bony material from one location in a body to another location in the same body, and has the advantage of producing minimal immunological complications. It is not always possible or even desirable to use an autograft. The acquisition of bone material from the body of a patient typically requires a separate operation from the implantation procedure.
25 Furthermore, the removal of material, oftentimes involving the use of healthy material from the pelvic area or ribs, has the tendency to result in additional patient discomfort during rehabilitation, particularly at the location of the material removal. Grafts formed from synthetic material have also been developed, but the difficulty in mimicking the properties of bone limits the efficacy of these implants.

30 As a result of the challenges posed by autografts and synthetic grafts, many orthopedic procedures alternatively involve the use of allografts, which are bone grafts from other human sources (normally cadavers). The bone grafts, for example, are placed in a host bone and serve as the substructure for supporting new bone tissue growth from the host bone. The grafts are sculpted to assume a shape that is appropriate for insertion at the
35 fracture or defect area, and often require fixation to that area as by screws or pins. Due to

the availability of allograft source material, and the widespread acceptance of this material in the medical community, the use of allograft tissues is certain to expand in the field of musculoskeletal surgery.

With respect to the overall structure of a given bone, the mechanical
5 properties vary throughout the bone. For example, a long bone (leg bone) such as the femur has both compact bone and spongy bone. Cortical bone, the compact and dense bone that surrounds the marrow cavity, is generally solid and thus carries the majority of the load in major bones. Cancellous bone, the spongy inner bone, is generally porous and ductile, and when compared to cortical bone is only about one-third to one-quarter as dense, one-tenth to
10 one-twentieth as stiff, but five times as ductile. While cancellous bone has a tensile strength of about 10-20 MPa and a density of about 0.7, cortical bone has a tensile strength of about 100-200 MPa and a density of about 2. Additionally, the strain to failure of cancellous bone is about 5-7%, while cortical bone can only withstand 1-3% strain before failure. It should also be noted that these mechanical characteristics may degrade as a result of numerous
15 factors such as any chemical treatment applied to the bone material, and the manner of storage after removal but prior to implantation (*i.e.* drying of the bone). In addition, bones have a grain direction similar to the grain found in wood, and thus the strength of the bone varies depending on the orientation of the grain.

Notably, implants of cancellous bone incorporate more readily with the
20 surrounding host bone, due to the superior osteoconductive nature of cancellous bone as compared to cortical bone. Furthermore, cancellous bone from different regions of the body is known to have a range of porosities. For example, cancellous bone in the iliac crest has a different porosity from cancellous bone in a femoral head. Thus, the design of an implant using cancellous bone may be tailored to specifically incorporate material of a desired
25 porosity.

Demineralization of cortical, cancellous, and corticocancellous bone of autograft, allograft, and xenograft types is known. In one form, bone powder or chips are chemically processed using an acid such as hydrochloric acid, chelating agents, electrolysis or other treatments. The demineralization treatment removes the minerals contained in the
30 natural bone, leaving collagen fibers with bone growth factors including bone morphogenic protein (BMP).

The use of expandable materials as a prosthetic element is disclosed in U.S. Patent No. 5,545,222 to Bonutti. Materials disclosed which expand when they come in
35 contact with water or other fluids include PEEK (polyether-etherketone), a desiccated

biodegradable material, or a desiccated allograft. As an example, a tendon can be compressed in a desiccated state, and as it imbibes water it expands and creates a firmer lock or tighter fit in the host site.

5 A shaped, swollen demineralized bone and its use in bone repair is disclosed in U.S. Patent No. 5,298,254 to Prewett et al. In general, cortical allogeneic bone tissue is preferred as the source of bone. Demineralized bone is contacted with a biocompatible swelling agent for a period of time sufficient to cause swelling of the piece.

10 A flexible implant using partially demineralized bone is disclosed in U.S. Patent No. 6,206,923 to Boyd et al. The bone implant has a first substantially rigid portion and a second substantially rigid portion which are joined by an intermediate portion that has been at least partially demineralized to create an area of flexibility in the bone implant. The pair of rigid bone portions cooperate to provide support for spacing between adjacent vertebra.

15 Demineralized bone has been disclosed for use as artificial ligaments in U.S. Patent No. 5,092,887 to Gendler. Completely or partially demineralized cortical bone is sliced in strips and rods of approximately 0.1-1.5 centimeters wide and 0.1-1.5 centimeters thick with compliant elasticity and longitudinal strength similar to natural ligaments and tendons. The strips or rods are used as artificial ligaments for in vivo replacement, repair and augmentation of damaged ligaments, tendons or other fibrous tissue that permanently
20 connects first and second body members such as the femur and tibia. Disclosure of a segmentally demineralized bone implant is found in U.S. Patent No. 6,090,998 to Grooms et al. The implant comprises a first mineralized portion or segment, and a second, flexible, demineralized portion or segment that are produced by machining a piece of cortical bone.

25 A textured, demineralized, and unitary mammalian bone section for providing a rigid, foraminous, collagen scaffold for allogenic skeletal reconstruction is disclosed in U.S. Patent No. 5,112,354 to Sires. Texturing or pore formation is carried out prior to demineralization to permit completeness of demineralization and additionally promote osteoinduction due to the increased surface area. Pores of between 200 μm and 2000 μm are created with a laser. The depth of the holes in the bone may be varied.

30 Also disclosed in U.S. Patent No. 5,899,939 to Boyce et al. is a bone-derived implant for load-supporting applications. The implant is formed of one or more layers of fully mineralized or partially demineralized cortical bone and, optionally, one or more layers of some other material such as fully demineralized bone or mineral substances such as hydroxyapatite. The layers constituting the implant are assembled into a unitary structure to

35

provide an implant with load-supporting properties. Superimposed layers are assembled into a unitary structure such as with biologically compatible adhesives.

U.S. Patent No. 5,556,430 discloses flexible membranes produced from organic bone matrix for skeletal repair and reconstruction. Completely or partially
5 demineralized organic bone is sliced into thin sheets. The bone may be perforated prior to demineralization, to increase the osteoinductivity of the final bone product. Similarly, U.S. Patent No. 5,298,254 to Prewett et al. discloses demineralized bone sliced into a thin sheet which can be used to patch an injury.

A cortical bone interference screw is disclosed in U.S. Patent No. 6,045,554
10 to Grooms et al. The interference screw has a cortical surface into which a self-tapping thread is machined.

In addition, U.S. Patent No. 5,053,049 to Campbell discloses the use of milling, grinding, and pulverizing to produce pulverized bone with the desired particle size. The pulverized bone can then be combined with any suitable biologically compatible or
15 inert carrier substance, which should have a consistency that imparts the desired flexible texture to the pulverized bone/carrier suspension, or should solidify to the desired consistency after molding or casting.

Despite these developments, there exists a need for implants formed from partially or fully demineralized cancellous bone. Furthermore, there exists a need for
20 implants formed of bone that have been selectively masked during demineralization so that portions of the bone are at least partially demineralized while other portions are substantially remain in the mineralized state.

SUMMARY OF THE INVENTION

25 The present invention relates to a bone sheet for implantation, the sheet including a demineralized field substantially surrounding at least one mineralized region. The sheet may be formed of cortical bone, and the at least one mineralized region may define at least one hole in the sheet. The at least one hole may be configured and dimensioned to receive at least one fastener. The sheet may have a thickness of between
30 about 0.5 mm and about 3 mm. The sheet may have ribs or projections providing localized thickness.

The present invention also relates to a method of forming a flexible bone sheet including: providing a sheet of cortical bone; creating at least one hole in the cortical sheet which is configured and dimensioned to receive a fastener; masking the cortical sheet
35 proximate the at least one hole to create a masked region surrounding the at least one hole;

and demineralizing the cortical sheet around the masked region. A plurality of masking elements may be removably attached to the sheet to provide masking proximate the at least one hole. The masking may be provided by at least one of the group consisting of tape, paint, and a coating. The method further may include creating perforations in the sheet that
5 are substantially smaller than the at least one hole. In addition, the method may further include cutting a bone section along a spiral path.

The present invention further relates to a sheet formed of bone including two or more strips of bone each having a bone grain orientation, wherein the bone grain orientation of at least one strip is disposed transverse to the grain orientation of another
10 strip. The strips may be interwoven, and may be selected from mineralized bone, demineralized bone, and partially demineralized bone. A portion of at least one strip may be demineralized. The strips may be interwoven to form a plurality of generally parallel rows and a plurality of generally parallel columns. The strips may have a width between
15 width of about 5 mm and a thickness of about 1 mm. The bone strips may be unitary in construction. At least one strip may be formed by braiding two or more bone fibers. Each bone strip may have a longitudinal axis and the bone grain orientation may be substantially parallel thereto.

The present invention also is related to a bone defect filler including a
20 demineralized cancellous bone section in a first geometry. The first geometry is compressible and dryable to a second geometry smaller than the first geometry, and the second geometry is expandable and rehydratable to a third geometry larger than the second geometry.

The present invention is further related to a method of filling an open region
25 with cancellous bone, the method including: demineralizing a section of cancellous bone; compressing the section; drying the compressed section; inserting the section into the open region; rehydrating the section; and allowing the section to expand to fill the open region.

In addition, the present invention relates to a method of providing a bone implant including: demineralizing a cancellous bone section having a first geometry;
30 compressing the bone section from the first geometry to a second geometry smaller than the first geometry; drying the bone section while the bone section has approximately the second geometry; and inserting the bone section into a space. When the bone section is inserted into the space, the bone section may be at least partially surrounded by a wall while having approximately the second geometry. The method may further include expanding the bone
35 section from the second geometry to a third geometry larger than the second geometry, as

well as allowing the bone section to expand to contact the wall. The bone section may be expanded by rehydrating.

The invention also relates to a method of maintaining a distance between vertebral bodies including: demineralizing a bone section having a first geometry; drying
5 the bone section; inserting the bone section in between vertebral bodies; and expanding the bone section to a second geometry. The bone section may be demineralized cortical bone. The drying step may include freeze drying the bone section, and the bone section may be expanded by hydrating. The method further may include compressing the bone section. The bone section may be cancellous bone. The method may be used to replace the nucleus
10 of a vertebral disc.

The invention further relates to a method of replacing nucleus of a vertebral disc including: providing a demineralized cortical bone section having a first geometry; inserting the bone section in between vertebral bodies; and expanding the bone section to a
15 second geometry. The bone section may be expanded by hydrating, and may be expanded to a height in the second geometry which is larger than the height in the first geometry. The bone section in the second geometry may have a top surface and a bottom surface, each of the top and bottom surfaces being configured to approximately match a concave vertebral endplate. The top and bottom surfaces may be convex with a radius of between about 50 mm and about 70 mm.

In addition, the invention relates to an implant including demineralized cancellous bone capable of being softened and compressed into a smaller first shape and hardened in said first shape, and capable of expanding into a second shape larger than said
20 first shape when resoftened and permitted to expand. The bone may be softened by hydration and may be hardened by dehydration. The bone may be configured and dimensioned to be received in an anatomical void. The first shape may be smaller than the
25 anatomical void, and the second shape may be about the same as the shape of the anatomical void. The second shape also may span a lateral dimension of the anatomical void. The implant may further include cortical bone.

In some embodiments, the implant is configured and dimensioned to be
30 disposed in a burr hole or void in the cranial region of the skull. The implant may form a burr hole cap including an upper cortical bone section and a lower, demineralized cancellous bone section, at least the lower section being sized to fill the burr hole when in the expanded second shape. In some embodiments, the implant is generally T-shaped and includes an upper cortical bone section and a lower, demineralized cancellous bone section.
35 In the expanded second shape, at least the lower section may be sized to contact walls of the

void. The upper section may have an arcuate portion for generally matching the contour of the skull. Slits may be included extending through at least a portion of one or both of the cortical bone and cancellous bone.

5 The present invention further is related to a bone sheet for implantation, the sheet including a demineralized field surrounding mineralized regions.

The present invention also is related to a bone defect filler including a demineralized cancellous bone section in a first geometry. The first geometry is compressible and dryable to a second geometry smaller than the first geometry, and the second geometry is expandable and rehydratable to a third geometry larger than the second
10 geometry.

The present invention is further related to a method of filling an open region with cancellous bone, the method including: demineralizing a section of cancellous bone; compressing the section; drying the compressed section; inserting the section into the open region; rehydrating the section; and allowing the section to expand to fill the open region.

15 In addition, according to one embodiment, a cranial void filler is described herein and comprises an upper mineralized cortical bone section, and a lower, at least partially demineralized cortical bone section, wherein the lower section is adapted and configured to contact walls of a cranial void. Preferably, the upper and lower sections form a T-shape. One or more slits may extend through the upper or lower sections, or both, or
20 portions thereof. The slits in the lower section may be colinear with the slits in the upper section. The upper section may have a rounded upper surface portion and also may have a curved lower surface portion.

According to another embodiment, a plate is described. The plate of this embodiment comprises a unitary body formed of cortical bone with a pair of portions
25 having a first width and a central portion disposed therebetween having a second width, the first width being greater than the second width, and the body having at least one partially demineralized region wherein the at least one partially demineralized region provides flexibility to the plate. The plate further may comprise a plurality of fastener holes. The body may have a central longitudinal axis and a first at least partially demineralized region
30 that is coaxial therewith. The first at least partially demineralized region may extend substantially across the entire length of the body. The fastener holes may be disposed proximate the ends of the body. The fastener holes may be disposed on a central longitudinal axis, and a first at least partially demineralized region may be coaxial therewith. One or more second at least partially demineralized regions may be disposed
35 transverse to the first at least partially demineralized region. The one or more second at

least partially demineralized regions may be generally perpendicular to the first at least partially demineralized region. The one or more second at least partially demineralized regions may intersect one or more fastener holes. The body may be relatively thin compared to its length or width. The at least partially demineralized region may extend substantially
5 across the second width. The body may have a central longitudinal axis and the at least partially demineralized region may extend transverse to the central longitudinal axis.

The plate may further comprise a plurality of fastener holes and the body may be generally dog-bone-shaped. The body may have a central longitudinal axis, and the length of the body along the central axis may be between about 10 mm and about 20 mm.
10 The first width may be between about 4 mm and about 7 mm and the body may have a thickness between about 1 mm and about 3 mm. The body may have a length of about 15 mm, a first width of about 5 mm, and a thickness of about 2 mm.

In a further embodiment, an implant comprising a unitary section of cortical bone having a first portion that is mineralized and a second portion that is at least partially
15 demineralized, wherein the mineralized portion includes a plurality of slits to facilitate bending of the unitary section is described.

A method of forming an implant also is described. The method comprises the steps of obtaining cortical fibers; at least partially demineralizing the fibers; allowing the fibers to clump together; and allowing the fibers to dry in a clumped state. The fibers may
20 be allowed to dry in a mold and may be pressed while they are clumped together. The fibers may be obtained by milling or other processes.

A still further embodiment describes an implant for maintaining a space in a bisected vertebrae. The implant according to this embodiment comprises a cortical bone cord having first and second free ends adapted for engaging exposed portions of the lamina,
25 and a region positioned between the first and second ends, wherein the region is at least partially demineralized to provide flexibility. The free ends may be mineralized. The cord may comprise a pair of at least partially demineralized regions with a mineralized region therebetween. The at least partially demineralized region may be centrally located between mineralized free ends.

30

BRIEF DESCRIPTION OF THE DRAWINGS

Preferred features of the present invention are disclosed in the accompanying drawings, wherein:

FIG. 1 shows a bone section of a femur;
35 FIGS. 2-3 show a cortical shell of the present invention;

FIG. 4 shows a cortical sheet formed from the cortical shell of FIG. 2;
FIG. 4A shows a spiral cortical sheet formed from the cortical shell of FIG.

2;

FIG. 4B shows a cortical sheet according to an alternative embodiment;
FIGS. 5-7 show various forms of cancellous bone of the present invention;

5

FIG. 8 shows a cage for filling with cancellous bone of FIG. 7;

FIG. 8A shows a cage filled with cancellous bone of FIG. 7;

FIG. 9 shows a femur section for filling with demineralized cancellous bone
of FIG. 6;

10

FIG. 9A shows a femur section filled with demineralized cancellous bone of
FIG. 6;

FIG. 10 shows a partially demineralized cancellous bone cylinder of the
present invention;

FIG. 11 shows a woven bone implant of the present invention;

15

FIG. 12 shows a demineralized cortical bone implant for nucleus
replacement according to the present invention;

FIGS. 13-15 show ligament replacements using bone implants of the present
invention;

FIGS. 16-18 show the use of partially demineralized bone struts for disc
replacement according to the present invention;

20

FIGS. 19-21 show a bendable implant of the present invention;

FIGS. 22-23 show bone cords of the present invention;

FIG. 24 shows a cortico-cancellous demineralized bone of the present
invention;

25

FIGS. 25-27 show cranial flap void and burr hole filling according to the
present invention;

FIGS. 28-29 show dogbone-shaped plates of the present invention;

FIG. 30 shows a cortical tack or suture anchor of the present invention; and

FIG. 31 shows an embodiment of a ribbed bone sheet.

30

DETAILED DESCRIPTION OF THE PREFERRED EMBODIMENT

The present invention in one embodiment is directed to an implantable bone
sheet that exhibits semi-pliable properties over portions of the sheet, while exhibiting semi-
rigid properties over other portions. The variation in properties is achieved by the selective
35 demineralization of bone preferably selected from a femur, tibia, humerus, fibula, ulna, and
radius. The terms "demineralization," "demineralized" and "at least partially

demineralized” as used herein are intended to refer to fully demineralized bone or partially demineralized bone. The term “fully demineralized” refers to bone where the minerals have been substantially completely removed from the bone whereas the term “partially demineralized” refers to bone where at least some portion of the minerals have been removed. As will become apparent, the degree of demineralization will depend upon the characteristics sought to be achieved in the implant.

Turning to FIG. 1, a bone section 10 of a femur has an inner surface 12, and an outer surface 14 which initially conforms to the natural shape of the bone. The wall thickness of bone section 10 varies, as indicated by thicknesses T_1 , T_2 , and T_3 . As shown in FIG. 2, bone section 10 may be machined to have a relatively uniform wall thickness T_4 , forming a cortical shell 16. Initially, cortical shell 16 is generally rigid, and holes 18 are formed from machined inner surface 20 to machined outer surface 22. Holes 18 may be provided in repeating patterns, or as desired.

In order to selectively screen areas of cortical shell 16 from direct contact with treatments such as hydrochloric acid, chelating agents, electrolysis, or other suitable treatments, a pair of masking elements 24 are disposed proximate each hole 18, with one masking element 24 disposed on machined inner surface 20 and the other disposed on machined outer surface 22. When tightly retained against surfaces 20, 22, masking elements 24 seal portions of cortical shell 16 from surrounding treatment fluids and reactions. In one preferred embodiment, masking elements 24 are toroidal in shape and have some flexibility such that the toroidal shape may be compressed to bear against the surface of cortical shell 16. Suitable masking elements include rubbery washers, o-rings, and grommets, which preferably have resistance to chemical attack from the treatments to which cortical shell 16 will be subjected. In order to create a secure seal, masking elements 24 are retained in place, using screws 26, the heads 28 of which bear against one masking element 24 and the threaded shafts 30 of which extend through the aligned pair of masking elements 24 and hole 18. Preferably, the screws are formed of a material that does not react with or otherwise contaminate cortical shell 16, such as a suitable polymer. Pressure is applied to masking elements 24 by threadably receiving a nut 32 on each threaded shaft 30 to bear against the other of the masking elements 24 in each pair that is not in contact with a head 28 of screw 26. A partial side view of a pair of masking elements 24 retained against cortical shell 16 are shown in FIG. 3. Although heads 28 of screws 26 are shown disposed inside cortical shell 16 adjacent machined inner surface 20 and nuts 32 are shown disposed outside cortical shell 16 adjacent machined outer surface 22, the reverse configuration is also contemplated.

Other masking elements 24 are also suitable for the present invention. For example, press-fit elastic rings with outer circumferential grooves may be used to seal the regions of cortical shell 16 around each hole 18, as long as adequate surface contact and/or pressure can be applied by the rings to prevent leakage of treatment liquids therebetween.

5 Alternatively, tapes or paints may be applied to serve as masking elements 24 to seal particular regions. For example, an air dry synthetic rubber coating may be used by dipping or otherwise painting select regions of an implant to mask the regions from treatment. Preferably, the aforementioned masking techniques are not only resistant to the bone treatments, but are readily removed following treatment.

10 Various configurations of masking elements 24 can be chosen to provide the desired amount of protection from treatments. As will now be explained, the present configuration is useful for providing limited regions of mineralized bone surrounded by a field of demineralized bone. Such a configuration is particularly useful, for example, in permitting the production of a generally flexible sheet of demineralized cortical bone with
15 mineralized, rigid regions bordering holes for use in receiving fasteners. Thus, surgical procedures necessitating the attachment of demineralized cortical bone for eventual assimilation into neighboring tissue may make use of a flexible sheet of the present invention that includes regions, for example, for receiving bone screws, with the regions being resistant to tearing or other damage during installation and stressing of the bone sheet.

20 After suitable masking procedures have been completed, cortical shell 16 is immersed or otherwise treated with a demineralizing agent. While the untreated cortical shell 16 initially possessed rigid properties, the selectively demineralized cortical shell 16 exhibits rubbery, elastic-like properties. Turning to FIG. 4, the treated cortical shell 16 has been cut across its length, such that a sheet 34 is formed. Sheet 34 includes a demineralized
25 field 36 surrounding mineralized regions 38 which are disposed about holes 18. Although not shown, a near mirror image is present on both surfaces 20, 22, and generally extends across the thickness of sheet 34.

Because the selectively demineralized cortical sheet is malleable, and thus generally can be made to conform to the shape of a given anatomical region, such a cortical
30 sheet may also find use in orthopaedic procedures as a "wrapping" material to surround areas requiring surgical intervention, or as a sealing material over defect areas such as regions excised due to tumors. In one embodiment, the cortical sheet may be used as a bridging agent for a bad fracture, and in another embodiment it may be used to encapsulate bone inside a barrier to retain blood and other products in a localized area. Furthermore, the
35 sheet may serve as a patch, such as to cover regions of the skull temporarily removed to permit surgical access to the cranial area. Also, if the sheet is perforated sufficiently, it may

serve as a mesh. Preferably, the perforations are substantially smaller than fastener holes provided in the sheet. In addition, the demineralized cortical sheet may be used to surround an iliac crest harvest, instead of the polymer sheet otherwise used. Preferably, the cortical sheet has a thickness of between about 0.5 mm and about 3 mm.

5 Notably, the above selective demineralization process may be used with bone portions already in sheet-like form prior to selective demineralization treatment. For example, strips of cortical bone may be precut from bone section 10, with holes 18 drilled accordingly. In the case of a cortical shell 16 as discussed above, however, the shell-like structure is preferably kept intact until after treatment due to its rigid and thus fracture-prone
10 characteristics. Although the application of masking elements 24 is more complicated with a shell geometry than with a sheet or strip geometry, the production of selectively demineralized sheets of significantly greater area is possible with the shell-like structures.

In an alternate embodiment shown in FIG. 4A, a bone section 10' may be cut in spiral form 37 so that the overall outer and inner geometry of the bone need not be
15 extensively machined to achieve a uniform wall thickness. Longitudinal cuts 39 also may be made such that individual sheets may be produced from the spiral. The cuts can be formed at regular distances through the spiral form 37 so that sheets of desired sizes can be produced. Thus, demineralized or partially demineralized sheets may be formed using this technique.

20 The mineralized regions 38 which are formed in the demineralized field 36 of sheet 34 may have a configuration other than shown in FIG. 4. For example, mineralized regions 38 may be larger or smaller than shown and may have a different configuration as shown in FIG. 4B. In addition, mineralized regions 38 may be connected together for example by a connecting strip or strut 38' of mineralized bone. The struts 38' may be
25 configured to be directed substantially along parallel axis to provide the sheet with different characteristics in different directions. In this manner, the connecting struts may provide the sheet with a preferred orientation. Struts 38" also may be provided and may be oriented in an orthogonal or other direction from strut 38' to provide the desired properties for sheet 34 in the direction of strut 38". By changing the shape and size of mineralized regions 38 and
30 struts 38' and 38", a sheet having desired directional properties may be designed.

The present invention is also directed to selectively demineralized cancellous bone for filling voids, bone defects, or other regions such as the cavities inside spinal cages. While mineralized cancellous bone may function in some load bearing capacity in wet and dry conditions, demineralized cancellous bone acts like a sponge when it is wet and exhibits
35 "memory" properties when dried and subsequently rehydrated. For example, turning to FIGS. 5-9, a block 40 of cancellous bone may initially be provided in a demineralized state,

with an initial geometry and volume V_1 . Block 40 may be submersed in water, and permitted to assume a soft, hydrated state in which it may be compressed to a smaller configuration such as pellet 42 with new volume $V_2 < V_1$. The compressed pellet 42 is then allowed to dry, and it hardens in the pellet-like configuration instead of the block-like
5 configuration. It should also be noted the when demineralized bone dries, it further shrinks, but it will re-expand when rehydrated. To regain the block-like configuration of block 40, pellet 42 is subsequently rehydrated and permitted to expand back to its original shape and regain soft, spongy properties. Because of this “memory” effect, the demineralized, cancellous bone may be supplied in standard geometries that can be used to fill
10 correspondingly sized cavities, or in geometries that are used to expand and fill any given shape smaller than or equal to their expanded size. In addition, the degree of expansion from compression (*i.e.*, as a function of the volume of void to be filled) may be used to produce a demineralized cancellous body with particular porosity. Swelling agents other than or in addition to water may also be employed.

15 In one embodiment, a bone section such as femur section 50 shown in FIG. 9 with an internal channel 52 may be loaded with a pellet 42, and when the pellet 42 is permitted to rehydrate, pellet 42 expands to fill the channel 52 as shown in FIG. 9A. This is particularly useful for irregularly shaped volumes as shown with channel 52.

In another embodiment, block 40 may also be compressed to a cylindrical
20 configuration such as a cylinder 44. Cylinder 44 is particularly well adapted for use with a hollow cage 46 with internal cavity 47 and perforations 48, shown in FIG. 8. When a suitably sized cylinder 44 is placed within cage 46 and rehydrated, cylinder 44 expands to fill internal cavity 47 and perforations 48 as shown in FIG. 8A. The cage 46 may or may not be provided with perforations 48 but expansion of the pellet 42 or cylinder 44 or other
25 dried cancellous bone section in perforations 48 helps to retain the bone section within the cage or shell.

In yet another embodiment, a pellet 42 or cylinder 44 may be delivered to a defect region in the body, and rehydrated to fill the defect. Other geometries and degrees of compression are contemplated as well, including a flat, pancake-like configuration, a donut-
30 like configuration, and a dumbbell configuration which may be used to expand within a defect such as a through-hole and plug either end of the through-hole. Based on the degree of compression, as well as the degree of demineralization, control of the degree of porosity of the demineralized cancellous bone insert may be achieved.

With reference to FIG. 10, a partially demineralized cancellous bone cylinder
35 60 is shown. Cylinder 60 includes mineralized, rigid portions 62, 64 and a demineralized, sponge-like section 66 therebetween. As discussed above with respect to selectively

screening areas of a bone portion from direct contact with chemical treatments, portions 62, 64 are preferably masked during treatment of cylinder 60. In addition, while section 66 is exposed to demineralization treatment, the degree of demineralization can be controlled as a function of the duration of treatment (*i.e.*, submersion time in demineralizing agent) and the strength of the treatment medium (*i.e.*, dilute or strong acid). Thus, the degree of “sponginess” or resiliency may be selected to meet a particular clinical application. Fully or partially demineralized cylinders such as cylinder 60 may be used, for example, to fill bony defects caused by the removal of bone screws during subsequent surgical procedures, to fill bony defects resulting from the removal of diseased bone, or as burr hole covers necessitated by cranial surgery.

Turning again to demineralized cortical bone, the ligament-like, pliable properties of the bone resulting from the demineralization treatment advantageously may be used. Because the properties of bone vary as a function of direction with respect to the bone grains, sheets of pliable bone may be woven together from strips of bone cut at particular orientations with respect to the grains. Woven bone implant 70 is shown in FIG. 11. Strips 72 running generally parallel to each other along a first direction form columns which are woven together with strips 74 that are running generally parallel to each other along a second grain direction forming rows. By disposing the strips in this manner, the properties of woven bone implant advantageously may be tailored to a particular need, for example through the selective orientation of the grains of criss-crossing bone strips. In some embodiments, strips 72, 74 of woven bone implant 70 may each be mineralized, demineralized, or partially demineralized. Also, each strip 72, 74 may include mineralized regions and demineralized regions. The orientation of the grain direction of each of the strips may further be used to tailor the properties of the woven bone implant 70.

As an illustrative, non-limiting example, bone strips 72, 74 may have an overall length less than or equal to the maximum length of a bone from which the strips are produced. Thus, bone strips 72, 74, for example, may be 12 inches in length if a bone has such an overall length. Moreover, the bone strips 72 may be much shorter than an overall bone length, and thus, for example one-inch bone strips 72 may be used. Bone strips 72, 74 may have a width of between about 1 mm and about 6 mm, and a thickness of between about 0.5 mm and about 2 mm. In another embodiment, bone strips 72, 74 may have a width of about 5 mm and a thickness of about 1 mm. The bone strips 72, 74 may be woven in a similar fashion to a basket, as shown for example in FIG 11. The resulting sheets may have the same uses and applications, for example, as the sheet described in FIG. 4.

In another exemplary embodiment, bone strips preferably at least about 1 mm in thickness and width may be braided, similar to carbon fiber, in uni-directional, bi-

directional, two-dimensional, and three-dimensional braid configurations. In yet another exemplary embodiment, individual bone fiber strands, preferably with a thickness of less than about 0.5 mm, may be braided and/or woven to create a bone cloth. An increase in strength may be realized by alternating grain directions, thereby also permitting larger
5 overall implants to be produced. Braids additionally may incorporate other materials, such as laminations, bonding agents, and/or bone inducing substances.

Demineralized bone may also be used in nucleus replacement. The nucleus pulposus is the inner gel-like portion of an intervertebral disc consisting of proteoglycans and a collagen meshwork. Younger individuals possess water in this region, but older
10 individuals lose water resulting in disc degeneration and dehydration. Such difficulties are commonly known as disc herniation - the nucleus pulposus herniates through the annulus when this occurs. In one preferred embodiment, as shown in FIG. 12, a demineralized cortical bone implant 80 having an initial height H_1 is freeze-dried so that it shrinks to a second height H_2 , with $H_1 > H_2$. In the smaller configuration, implant 80 is loosely inserted
15 into a degenerated disc region to provide support, and subsequently rehydrated so that it expands to provide rubber-like structural support so that proper disc height is regained. An implant 80 used in nucleoplasty preferably has an initial height H_1 at its largest dimension between about 3 mm and about 17 mm. Top and bottom surfaces 81a, 81b preferably may be radiused to approximate the concavity of the vertebral endplates, and preferably have a
20 radius of between about 50 mm and about 70 mm. In one exemplary embodiment, top and bottom surfaces 81a, 81b are protruding and convex with a radius of about 60 mm.

Referring to FIGS. 13-15, the use of demineralized and partially demineralized cortical bone in ligament replacements is shown. A demineralized cortical bone, generally rectangular plate 82 may be fastened in place using fasteners 84 located in
25 corners of the plate. In other embodiments, alternate shapes of plate 82 may be used. The plate may be used, for example, to replace the anterior longitudinal ligament (ALL) that extends over the length of the lumbar spine anterior to the vertebral bodies, or the interspinous ligament (ISL) that attaches adjoining spinous processes and serves, for example, to limit forward bending. As shown for example in FIG. 14, partially
30 demineralized cortical bone for use in ALL may include a demineralized section 86 bordered above and below by mineralized sections 88. The mineralized sections retain rigidity, and thus are most suitable for containing fastener holes 90. Referring to FIG. 15, a lateral view of the spine is shown with a partially demineralized cortical bone 92 used to replace an ISL disposed adjacent the spinous process.

35 Turning to FIGS. 16-18, the use of demineralized or partially demineralized femoral struts for disc replacement is shown. The pertinent spinal structures are shown in

FIG. 16, with a pair of vertebral bodies 100 disposed adjacent a disc 102. A generally cylindrical femoral strut 104 with teeth 106 and a central hole 108, includes a demineralized central portion 110 and mineralized portions 112. Once femoral strut 104 is implanted between vertebral bodies 100, mineralized portions 112 advantageously fuse with vertebral
5 bodies 100, while demineralized central portion 110 mimics the behavior of disc-like collagen.

Another demineralized cortical bone implant 120 is shown in FIGS. 19-21. Implant 120 preferably includes a partially demineralized layer 122 and a mineralized, mechanically stronger layer 124. Slits 126 are cut in mineralized layer 124, and the
10 pliability of layer 122 permits implant 120 to be bent as shown in FIGS. 20-21.

Referring to FIGS. 22-23, demineralized cortical bone may also be used in laminoplasty, the replacement of bone at the site of a previous excision in order to re-establish structural support and protection of the spinal cord. In laminectomy, the lamina and spinous process have been removed, while in laminotomy only a portion of the lamina
15 is removed. A demineralized cortical bone cord 130 with mineralized cortical portions 132 and demineralized portions 134 to provide flexibility. Cord 130 may have free ends suitable for fixation, for example, to the exposed portions of the lamina following removal of a lamina section. Alternatively, a demineralized cortical bone cord 140 with mineralized
20 cortical portions 142 and demineralized central portion 144 may similarly be used. Cords 130, 140 are used to bridge the gap created by the tissue excision. As discussed above with respect to other embodiments of the present invention, fastener holes may be located in the mineralized portions of the cortical bone cords.

Turning to FIG. 24, a section 150 of cortico-cancellous demineralized bone taken, for example, from the wall where the transition from the midshaft to the condyle of a
25 bone occurs. A layer of cancellous bone 152 and a layer of cortical bone 154 may be jointly demineralized, resulting in a bone implant with two types of properties. Such selectively demineralized bone is particularly useful in maxillofacial procedures including reconstructive procedures as well as elective procedures such as face lifts, chin augmentations, cheek enhancements, and eye brow lifts. The demineralized region is
30 relatively soft, while the mineralized region remains relatively hard and thus better accommodates implant fixation screws.

As shown in FIGS. 25-27, demineralized bone also can be used as a cranial flap void filler. In particular, during craniotomies, which are surgical procedures performed in the treatment of various brain problems such as tumors, aneurysms, blood clots, head
35 injuries, abscesses, and the like, access to the brain is achieved by the creation of a hole in the bone that defines the skull. The hole or "window" in the skull is usually created by

identifying the area of the brain to which access is needed, drilling several holes into the skull near the periphery of this area, inserting a cutting tool into one of the holes, and making cuts from one hole to another. Removal of the cut-out area of the skull, generally referred to as a bone flap, allows the desired access to the brain. After the desired medical or surgical procedure on the brain has been performed, the bone flap must be replaced and held in a stable position to allow the skull to heal.

Typically, when the bone flap is replaced in the region from which it was removed, gaps or voids remain between the bone flap and skull due to the cutting operation. To fill the gaps or voids, pliable, demineralized cortical bone may be used. For example, pliable, demineralized cortical bone may be inserted in the void 168 formed in the cranial region 166 of the skull. In one preferred embodiment, a generally T-shaped bone implant 160 is inserted in void 168 so that first portion 162 fits in void 168, while second portion 164 abuts the top of cranial region 166 of the skull. Preferably, first portion 162 of bone implant 160 is demineralized to provide flexibility, while second portion 164 remains mineralized bone to provide stiffness. To provide flexibility, slits 165a may extend through parts of second portion 164. Similarly, slits 165b may extend through a part of first portion 162, and may be aligned with slits 165a. In one exemplary embodiment, implant 160 is provided with an upper side 169a of second portion 164 that may be arcuate in cross-section and preferably concave. In another exemplary embodiment, second portion 164 is provided with lower arcuate portions 169b that generally match the contour of the skull in the region of use. An arcuate, upper portion 169c also may be provided. Such a flexible implant 160 thus permits the filling of a curved channel such as a void 168. In an alternate embodiment, demineralized cancellous bone may be used.

Burr holes 170 may be filled with covers formed of fully or partially demineralized bone as well. A burr hole cap 172 is shown in FIG. 27, with an upper portion 174 and a lower portion 176. Burr hole cap 172 may be formed of cortico-cancellous bone, with a cortical upper portion 174 and a lower cancellous portion 176. In addition, a portion of cap 172 may be demineralized, such as upper portion 174, while another portion such as lower portion 176 may be mineralized.

The “memory” properties of demineralized cancellous bone, as discussed above, may also be used to provide selectively compressible portions of a bone implant such as T-shaped bone implant 160 or burr hole cap 172. For example, in one preferred embodiment, lower portion 176 of cap 172 is demineralized cancellous bone, while upper portion 174 is mineralized or demineralized cortical bone. The demineralized cancellous bone of lower portion 176 may be hydrated so that it assumes a soft state in which it may be compressed to a smaller configuration, and then subsequently allowed to dry and harden in

the compressed state. After insertion of the compressed lower portion 176 into a burr hole 170, lower portion 176 may be rehydrated and permitted to expand back to its original shape, regaining soft, spongy properties, and filling burr hole 170.

In an alternate embodiment of T-shaped bone implant 160, first portion 162
5 is formed of demineralized cancellous bone and fits in void 168, while second portion 164 is formed of cortical bone and is disposed proximate the top of cranial region 166 of the skull. Thus, the aforementioned “memory” properties of demineralized cancellous bone may be used to provide a desired fit of T-shaped bone implant 160 in void 168.

In yet another alternate embodiment, T-shaped bone implant 160 and one or
10 more burr hole caps 172 may be provided as a unitary structure. The variable dimensions of the void 168 and burr holes 170 may be accommodated by the expandable “memory” properties of the demineralized cancellous bone portion.

Turning to FIGS. 28-29, additional embodiments of implants produced from partially demineralized cortical bone are shown. Preferably, dogbone-shaped or dumbbell-
15 shaped plates 180, 186 are formed of a unitary body with a pair of generally symmetrical side portions having a first width W_1 , and a central portion disposed therebetween having a second width W_2 which is less than the first width. Plate 180 includes mineralized portions 182 and demineralized portion 184. Portion 184 is disposed diagonally across plate 180 to facilitate movement. In the embodiment of plate 186, demineralized portions 188, 190,
20 which may be perpendicular or otherwise transversely disposed with respect to each other, permit angulation of plate 186 with more than one degree of freedom. Such dogbone plates may be used, for example, in thin areas of the face where fixation is required. In one embodiment, plates 180, 186 may have, for example, an overall length of between about 10 mm and about 20 mm, as measured for example along the central longitudinal axis defined
25 by demineralized portion 188 of plate 186. In addition, plates 180, 186 preferably may have, for example, a maximum width W_1 between about 4 mm and about 7 mm, as measured for example along the axis defined by demineralized portion 190 of plate 186, and may have, for example, a thickness between about 1 mm and about 3 mm. In one exemplary embodiment, a dogbone-shaped plate 180, 186 has a length of about 15mm, a
30 maximum width of about 5mm, and a thickness of about 2 mm.

Referring to FIG. 30, a cortical tack or suture anchor 210 is shown, including a head 212, eyelet 214, and shaft 215 with ribs 216. All areas of suture anchor 210 except ribs 216 may be masked and thereafter subjected to a demineralizing agent. Following treatment, head 212 remains hard, while demineralized ribs 216 are malleable. Once
35 inserted into a hole in bone, the demineralized ribs 216 of suture anchor 210 permit an interference fit, and may serve as resilient o-rings. Thus, when a suture anchor 210 is

pressed into a hole, the demineralized o-ring structure provides holding power to resist removal or backout of the suture anchor from the hole.

In FIG. 31 an implantable bone sheet 134 that exhibits selective directional properties is disclosed. Bone sheet 134 may be formed of mineralized or demineralized bone, and may be produced from, and in a manner similar to, cylindrical tube or shell 16 of FIGS. 1 and 2. Sheet 134 has a longitudinal axis 150 and a cross axis 155 perpendicular to longitudinal axis 150. A plurality of corrugations or ribs 165 extend along the length L of the sheet 134 parallel to longitudinal axis 150. The ribs 165 provide a greater thickness and stiffness to the sheet. In particular the ribs resist bending in the direction along which they extend while providing greater flexibility in the opposite direction. The sheet is more flexible in the direction opposite the direction of the ribs and may be formed into a tube similar to that shown in FIGS. 2 and 8 (but with the ribs, although the perforations may or may not be included).

The ribs may be of any shape, for example, square or triangle cross-section. As shown in FIG. 31, the ribs may be formed having pointed or rounded peaks 166 and may form troughs 168 therebetween. The troughs 168 may have a flat section 169 which separates adjacent ribs 165. Instead of ribs 134, projections such as, for example, teeth may be used. By varying the thickness, height, shape, number and direction of the ribs 165 or projections, the sheet 134 can be tailor designed to have the desired properties in the desired directions.

The sheet 134 may be formed to have a mineralized bone section 170 and demineralized section 175. The demineralized section provides flexibility to the sheet while the mineralized section provides stiffness. Alternatively, the sheet 134 may be formed by machining a bone section, whether it be in the form of a sheet or precursor tube, to have the ribs or other projections and then subjecting the sheet or tube to demineralization agents. The sheet or tube may be subjected to demineralization from one or both sides. Where the sheet or tube is subject to demineralization agents from side 185, the sheet may take the form shown in FIG. 31 where it has a demineralized section 175 and a mineralized section 170. The demineralizing agents also may attack only the side 180, having the ribs as shown in FIG. 31, in which case because of the greater thickness at the ribs, the demineralized section of the sheet will take a shape that conforms more closely to the outer configuration of the ribbed side of the sheet. In other words, the interface between the demineralized section and the mineralized section may not have the straight planar configuration as shown in FIG. 31 but instead will approximate the shape of the ribs.

If the demineralizing agent were applied to both sides of the sheet or tube, the resulting sheet may have an interior mineralized section which corresponds roughly to

the ribs because of the greater thickness of the sheet where the ribs are located. Depending upon the time with which the demineralizing agent is applied to the bone section, the thickness of the mineralized section can be varied. If the mineralized agents were applied to both sides for a sufficient amount, the resulting sheet or tube may have a plurality of interior
5 discrete mineralized sections between and dispersed in the field of demineralized bone. As a result of the ribs or projections which provide a greater localized thickness, a mineralized section may remain while its surrounding areas where the sheet may be less thick has no mineralized bone remaining. The ribs or projections are configured to provide the desired flexibility in the desired direction while retaining the desired stiffness in the desired
10 direction. The sheet 134 is preferably formed of cortical bone and the grain of bone material may extend in the same or a different direction than the ribs 165.

The side 185 may be substantially smooth, or may have ribs as illustrated for side 180 in FIG. 31, or other projections. Side 185 may have a ribbed design similar to or different than side 180. For example, the ribs on side 185 may extend in the same direction
15 as side 180 or may extend in a direction transverse or orthogonal to the ribs of side 180. It will be appreciated that while FIG. 31 has been illustrated with ribs, the sheet may alternatively have projections such as teeth on one or both sides. The sheet also may be provided with perforations or be subject to masking selective areas as illustrated in FIGS. 1-4.

20 As discussed herein, demineralized cortical, cancellous, and cortico-cancellous bone may be used as a relatively soft substance for enhancing anatomical areas such as during plastic surgery, or for filling defect regions resulting from disease, congenital conditions, or surgical procedures. Demineralized bone of the present invention may also be formed into screws, which advantageously are less brittle than screws formed of
25 mineralized bone. In particular, selective demineralization may be undertaken for portions of a screw structure so that a surgeon applying the screw receives tactile feedback from the pliable, demineralized portion when certain stress is reached. Angulation control also is possible by selectively demineralizing the screw.

Other processes of the present invention include the recovery of the minerals
30 removed from the demineralizing of the bones, and the reintroduction of these minerals into bone implants. In addition, the various machining operations for the production of bone implants produce different bone fibers, bone powder and particulates, bone chips, or combinations thereof. Milling of cortical bone can produce long and short fibers. The thickness and length of the fibers is a function of the blade design, milling speed of the
35 milling operation, and the feed rate of the bone. Grinding can produce powder or particulates of varying sizes, which may be sieved to separate the powder or particulates

into desired size ranges. Moreover, bone chips may be produced by a lathe operation. The properties and usage of these by-products vary depending upon the degree of any demineralization. For example, cortical long fibers produced by milling of bone may be treated in hydrochloric acid for an extended period of time, and allowed to demineralize to a
5 mushy consistency. The demineralized long fibers tend to clump together. Additional pressing means may be used to further encourage clumping. Demineralized cortical fibers may be pressed together in a wet or semi-wet state in a compression molding operation to produce a part of a desired geometry. Once dry, the solid part has significant strength.

While various descriptions of the present invention are described above, it
10 should be understood that the various features can be used singly or in any combination thereof. Therefore, this invention is not to be limited to only the specifically preferred embodiments depicted herein.

Further, it should be understood that variations and modifications within the spirit and scope of the invention may occur to those skilled in the art to which the invention
15 pertains. For example, a demineralized cortical shell may be sized to behave like a rubber band, and used for a similar purpose. Accordingly, all expedient modifications readily attainable by one versed in the art from the disclosure set forth herein that are within the scope and spirit of the present invention are to be included as further embodiments of the present invention. The scope of the present invention is accordingly defined as set forth in
20 the appended claims.

25

30

35

THE CLAIMS

What is claimed is:

5

1. A bone sheet for implantation, the sheet comprising an at least partially demineralized field substantially surrounding at least one mineralized region.

2. The bone sheet according to claim 1 having at least one rib providing
10 localized thickness to the sheet.

3. The bone sheet according to claim 1, wherein the sheet is formed of cortical bone.

4. The bone sheet according to claim 3 wherein the sheet comprises a
15 plurality of mineralized regions.

5. The bone sheet according to claim 4 wherein at least two of the mineralized regions are connected by a strut.

20

6. The bone sheet according to claim 3, wherein the at least one mineralized region defines at least one hole in the sheet.

7. The bone sheet according to claim 6, wherein the at least one hole is
25 configured and dimensioned to receive at least one fastener.

8. The bone sheet according to claim 3, wherein the sheet has a thickness of between about 0.5 mm and about 3 mm.

30

9. A method of forming a flexible bone sheet comprising:
providing a sheet of cortical bone;
creating at least one hole in the cortical sheet which is configured and dimensioned to receive a fastener;
masking the cortical sheet proximate the at least one hole to create a masked
35 region surrounding the at least one hole; and

applying demineralizing agents to the cortical sheet around the masked region.

10 10. The method according to claim 9, wherein a plurality of masking
5 elements are removably attached to the sheet to provide masking proximate the at least one
hole.

 11. The method according to claim 9, wherein the masking is provided
by at least one of the group consisting of tape, paint, and a coating.
10

 12. The method according to claim 9, further comprising creating
perforations in the sheet that are substantially smaller than the at least one hole.

 13. The method according to claim 9, further comprising cutting a bone
15 section along a spiral path.

 14. A sheet formed of bone comprising two or more strips of bone each
having a bone grain orientation, wherein the bone grain orientation of at least one strip is
disposed transverse to the grain orientation of another strip.
20

 15. The sheet according to claim 14, wherein the strips are interwoven.

 16. The sheet according to claim 14, wherein the strips are selected from
at least one of the group consisting of mineralized bone, demineralized bone, and partially
25 demineralized bone.

 17. The sheet according to claim 14, wherein a portion of at least one
strip is at least partially demineralized.

30 18. The sheet according to claim 14, wherein the strips are interwoven to
form a plurality of generally parallel rows and a plurality of generally parallel columns.

 19. The sheet according to claim 14, wherein the strips have a width
between about 1 mm and about 6 mm.
35

20. The sheet according to claim 19, wherein the strips have a thickness of between about 0.5 mm and about 2 mm.
21. The sheet according to claim 14, wherein the strips have a width of
5 about 5 mm and a thickness of about 1 mm.
22. The sheet according to claim 14, wherein the bone strips are unitary in construction.
- 10 23. The sheet according to claim 14, wherein at least one strip is formed by braiding two or more bone fibers.
24. The sheet according to claim 14, wherein each bone strip has a longitudinal axis and the bone grain orientation is substantially parallel thereto.
15
25. A method of providing a bone implant comprising:
demineralizing a cancellous bone section having a first geometry;
compressing the bone section from the first geometry to a second geometry smaller than the first geometry;
20 drying the bone section while the bone section has approximately the second geometry; and
inserting the bone section into a space.
26. The method of claim 25, wherein when the bone section is inserted
25 into the space, the bone section is at least partially surrounded by a wall while having approximately the second geometry.
27. The method of claim 25, further comprising:
expanding the bone section from the second geometry to a third geometry
30 larger than the second geometry.
28. The method of claim 27, wherein the bone section is expanded by rehydrating.
- 35 29. The method of claim 27, further comprising allowing the bone section to expand to contact the wall.

30. A method of maintaining a distance between vertebral bodies comprising:
- 5 demineralizing a bone section having a first geometry;
drying the bone section;
inserting the bone section in between vertebral bodies; and
expanding the bone section to a second geometry.
31. The method of claim 30, wherein the bone section is demineralized cortical bone.
- 10 32. The method of claim 30, wherein the drying step comprises freeze drying the bone section.
33. The method of claim 30, wherein the bone section is expanded by
15 hydrating.
34. The method of claim 30, further comprising compressing the bone section.
- 20 35. The method of claim 34, wherein the bone section is cancellous bone.
36. The method of claim 30 used to replace the nucleus of a vertebral disc.
- 25 37. A method of replacing nucleus of a vertebral disc comprising:
providing a demineralized cortical bone section having a first geometry;
inserting the bone section in between vertebral bodies; and
expanding the bone section to a second geometry.
- 30 38. The method of claim 37, wherein the bone section is expanded by hydrating.
39. The method of claim 37, wherein the bone section is expanded to a height in the second geometry which is larger than the height in the first geometry.

35

40. The method of claim 37, wherein the bone section in the second geometry has a top surface and a bottom surface, each of the top and bottom surfaces being configured to approximately match a concave vertebral endplate.
- 5 41. The method of claim 40, wherein the top and bottom surfaces are convex with a radius of between about 50 mm and about 70 mm.
- 10 42. An implant comprising demineralized cancellous bone capable of being softened and compressed into a smaller first shape and hardened in said first shape, and capable of expanding into a second shape larger than said first shape when resoftened and permitted to expand.
- 15 43. The implant of claim 42, wherein said bone is softened by hydration.
44. The implant of claim 42, wherein said bone is hardened by dehydration.
- 20 45. The implant of claim 42, wherein said bone is configured and dimensioned to be received in an anatomical void.
46. The implant of claim 45, wherein said first shape is smaller than said anatomical void.
- 25 47. The implant of claim 46, wherein said second shape is about the same as the shape of said anatomical void.
48. The implant of claim 46, wherein said second shape spans a lateral dimension of said anatomical void.
- 30 49. The implant of claim 42, further comprising cortical bone.
50. The implant of claim 49, wherein the implant is configured and dimensioned to be disposed in a burr hole or void in the cranial region of the skull.
- 35 51. The implant of claim 50, wherein the implant forms a burr hole cap comprising an upper cortical bone section and a lower, demineralized cancellous bone

section, at least the lower section being sized to fill the burr hole when in the expanded second shape.

52. The implant of claim 50, wherein the implant is generally T-shaped
5 and comprises an upper cortical bone section and a lower, demineralized cancellous bone section.

53. The implant of claim 52, wherein in the expanded second shape, at
least the lower section is sized to contact walls of the void.
10

54. The implant of claim 52, wherein the upper section has an arcuate
portion for generally matching the contour of the skull.

55. The implant of claim 49, further comprising slits extending through
15 at least a portion of one or both of the cortical bone and cancellous bone.

56. A cranial void filler comprising:
an upper mineralized cortical bone section, and
a lower, at least partially demineralized cortical bone section,
20 wherein the lower section is adapted and configured to contact walls of a cranial void.

57. The cranial void filler of claim 56, wherein the upper and lower
sections form a T-shape.

58. The cranial void filler of claim 56, further comprising at least one slit
25 extending through at least a portion of at least one of the upper and lower sections.

59. The cranial void filler of claim 56, wherein at least one slit extends
through a portion of the upper section and at least one slit extends through the lower
30 section.

60. The cranial void filler of claim 59, wherein the at least one slit in the
lower section is colinear with the slit in the upper section.

61. The cranial void filler of claim 56, wherein the upper section has a
35 rounded upper surface portion.

62. The cranial void filler of claim 56, wherein the upper section has a curved lower surface portion.
63. A plate comprising:
5 a unitary body with a pair of portions having a first width and a central portion disposed therebetween having a second width, the first width being greater than the second width, and the body being formed of cortical bone; and
at least one partially demineralized region,
wherein the at least one partially demineralized region confers flexibility to
10 the plate.
64. The plate of claim 63, further comprising a plurality of fastener holes.
65. The plate of claim 64, wherein the body has a central longitudinal
15 axis and a first at least partially demineralized region that is coaxial therewith.
66. The plate of claim 65, wherein the first at least partially demineralized region extends substantially across the entire length of the body.
- 20 67. The plate of claim 65, wherein the fastener holes are disposed proximate ends of the body.
68. The plate of claim 67, wherein the fastener holes are disposed on a central longitudinal axis, and a first at least partially demineralized region is coaxial
25 therewith.
69. The plate of claim 68, wherein a at least a second at least partially demineralized region is disposed transverse to the first at least partially demineralized region.
30
70. The plate of claim 69, wherein the at least second at least partially demineralized region is generally perpendicular to the first at least partially demineralized region.
- 35 71. The plate of claim 70, wherein the at least second at least partially demineralized region intersects at least one fastener hole.

72. The plate of claim 63, wherein the body is relatively thin compared to its length or width.
73. The plate of claim 63, wherein the at least one partially demineralized
5 region extends substantially across the second width.
74. The plate of claim 73, wherein the body has a central longitudinal axis and the at least partially demineralized region extends transverse to the central longitudinal axis.
10
75. The plate of claim 74, further comprising a plurality of fastener holes.
76. The plate of claim 63, wherein the body is generally dogbone shaped.
77. The plate of claim 63, wherein the body has a central longitudinal axis, and the length of the body along the central axis is between about 10 mm and about 20 mm.
15
78. The plate of claim 77, wherein the first width is between about 4 mm
20 and about 7 mm.
79. The plate of claim 78, wherein the body has a thickness between about 1 mm and about 3 mm.
80. The plate of claim 78, wherein the body has a length of about 15 mm, a first width of about 5 mm, and a thickness of about 2 mm.
25
81. An implant comprising a unitary section of cortical bone having a first portion that is mineralized and a second portion that is at least partially demineralized,
30 wherein the mineralized portion includes a plurality of slits to facilitate bending of the unitary section.
82. A method of forming an implant comprising:
obtaining cortical fibers;
35 at least partially demineralizing the fibers;
allowing the fibers to clump together; and

allowing the fibers to dry in a clumped state.

83. The method of claim 82, wherein the fibers are allowed to dry in a mold.

5

84. The method of claim 83, further comprising pressing the fibers while the fibers are clumped together.

10

85. The method of claim 82, wherein the fibers are obtained by milling.

86. An implant for maintaining a space in a bisected vertebrae comprising:

a cortical bone cord having a first and second free ends adapted for engaging exposed portions of the lamina, and a region positioned between the first and second ends, wherein the region is at least partially demineralized to provide flexibility.

15

87. The implant of claim 86, wherein the free ends are mineralized.

88. The implant of claim 86, wherein the cord further comprises a pair of at least partially demineralized regions with a mineralized central region therebetween.

20

89. The implant of claim 86, wherein the at least partially demineralized region is centrally located between mineralized free ends.

25

30

35

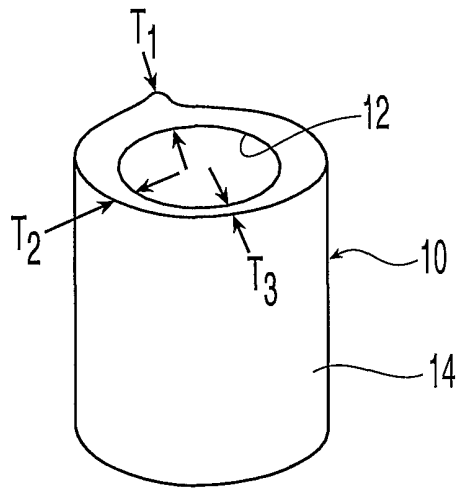

Fig. 1

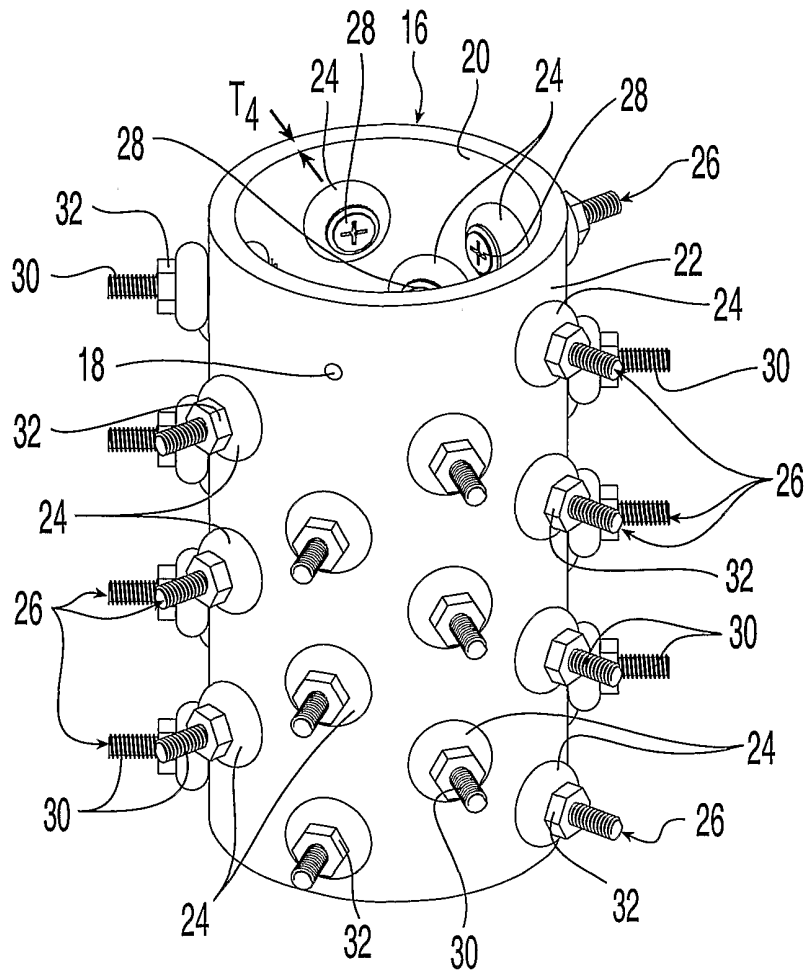

Fig. 2

2/14

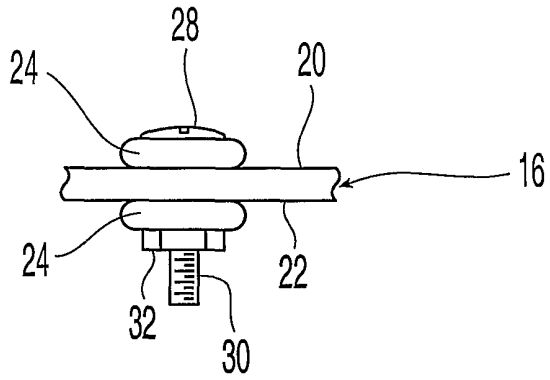

Fig. 3

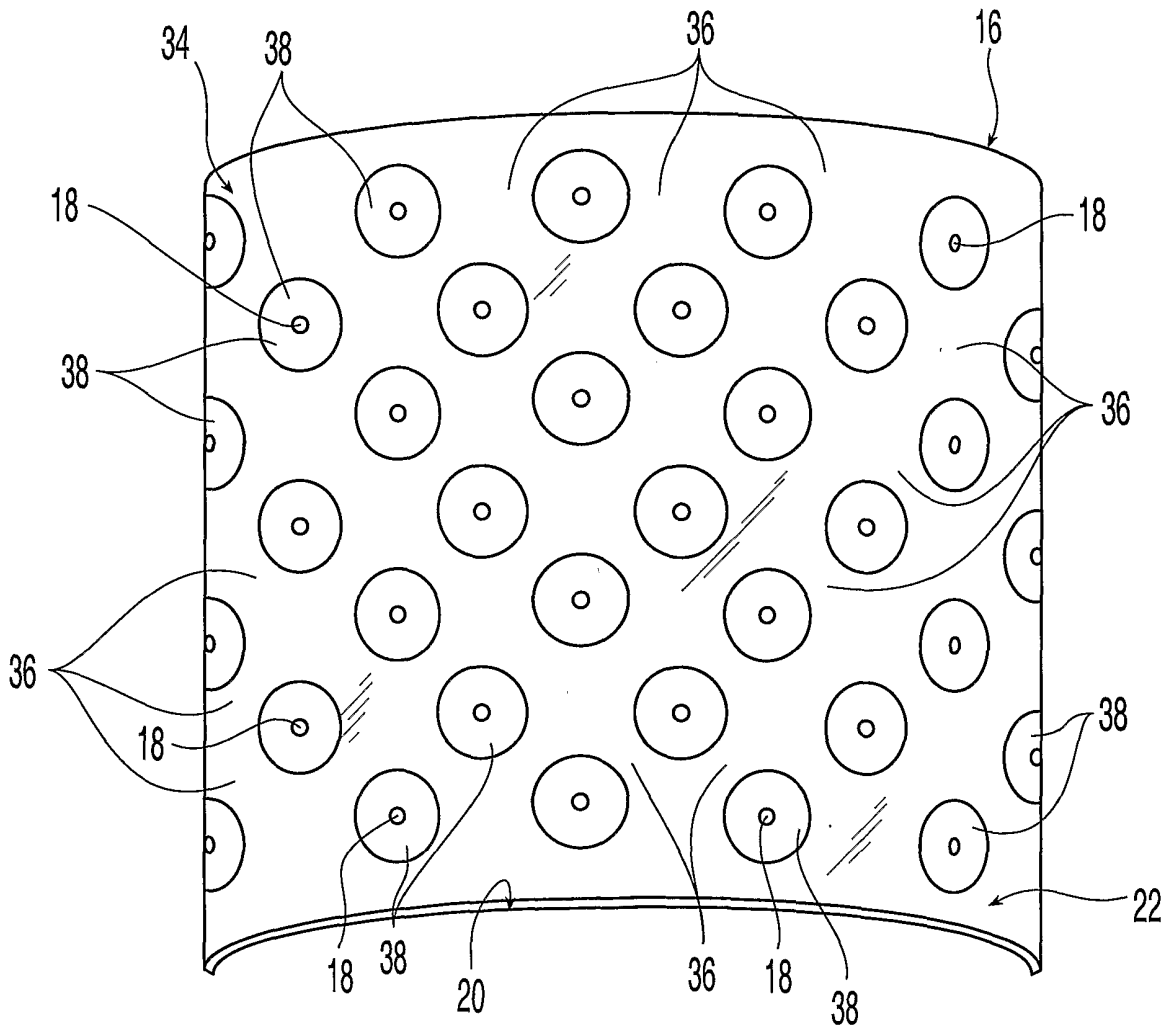

Fig. 4

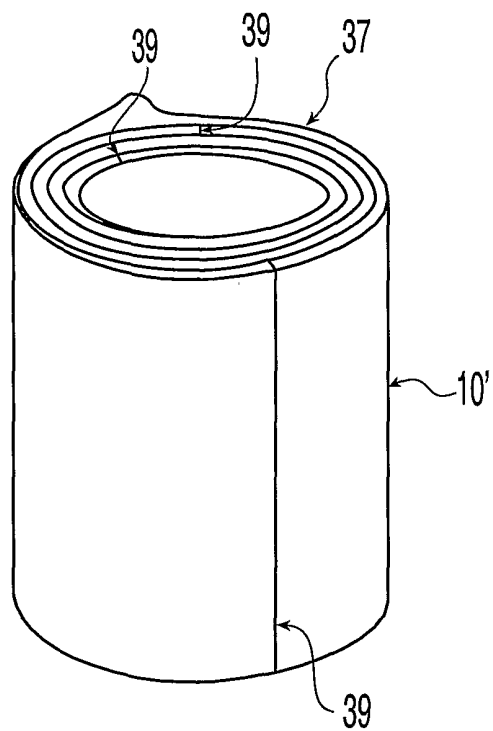

Fig. 4A

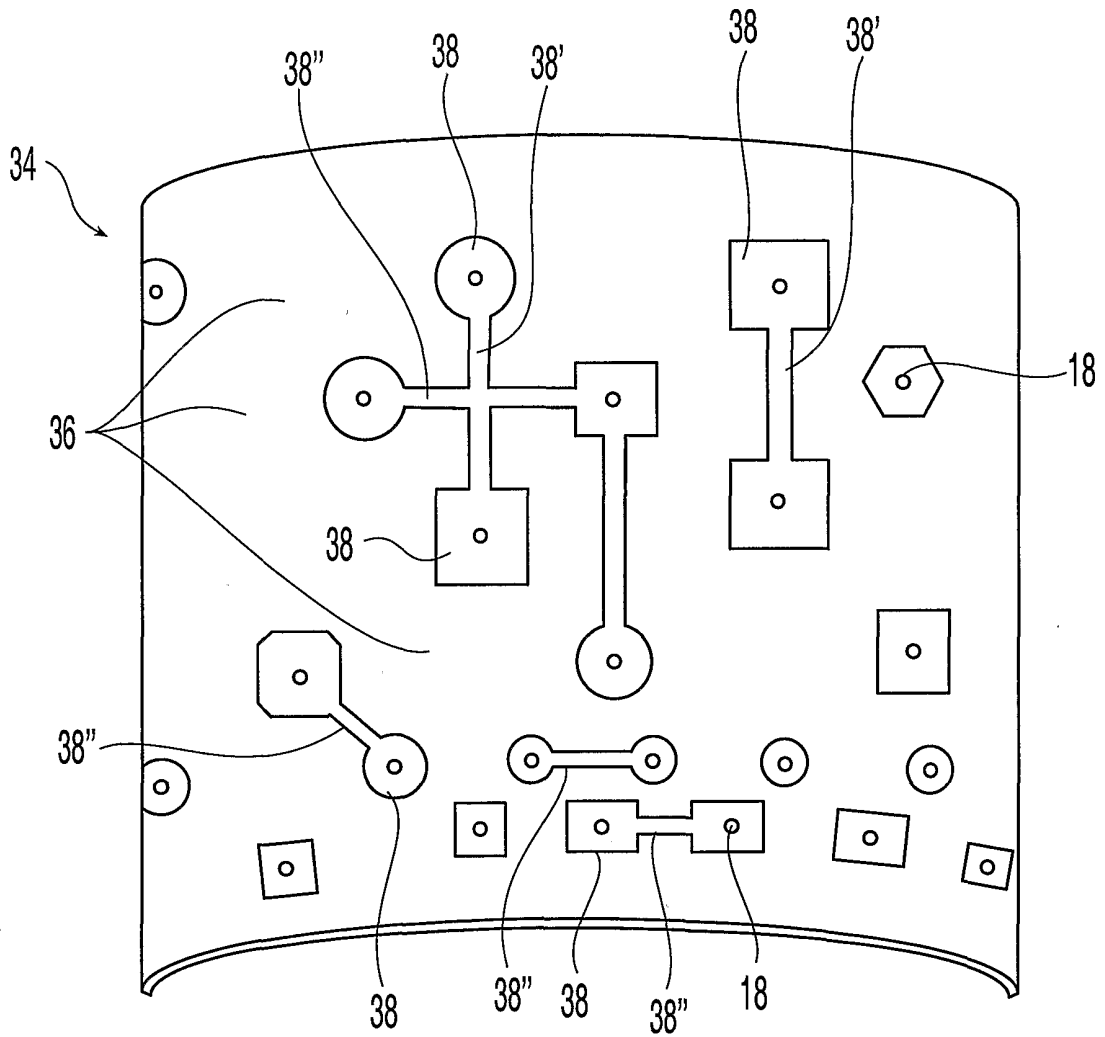

Fig. 4B

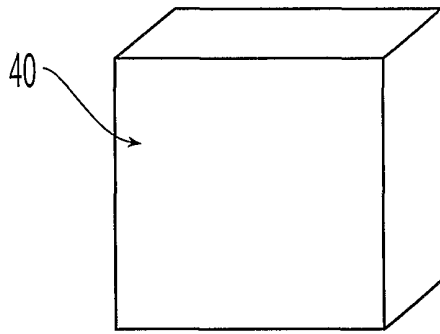

Fig. 5

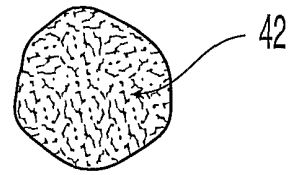

Fig. 6

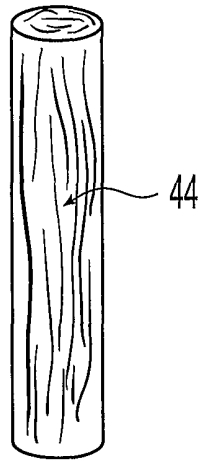

Fig. 7

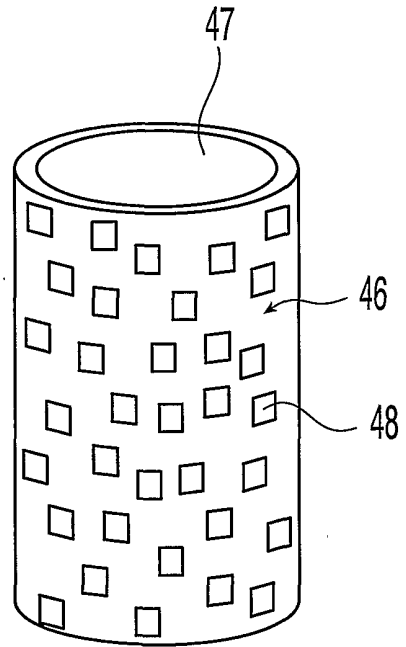

Fig. 8

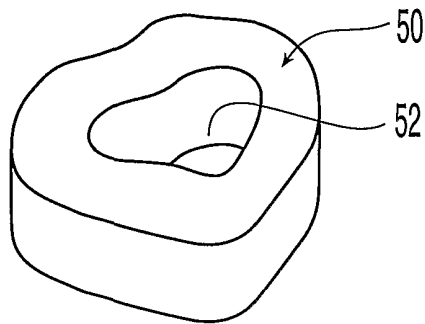

Fig. 9

6/14

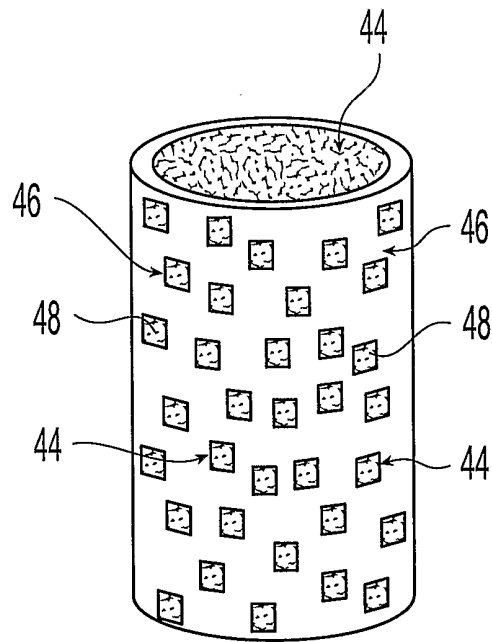

Fig. 8A

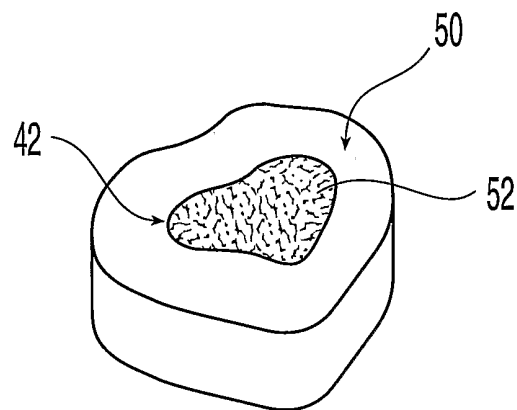

Fig. 9A

7/14

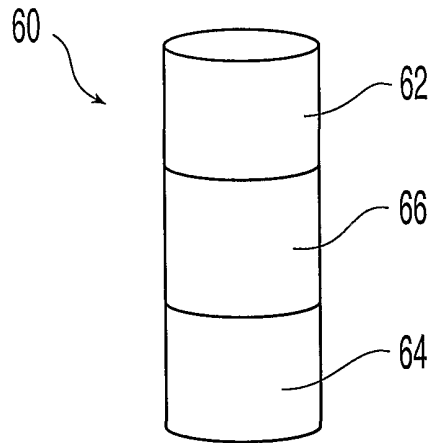

Fig. 10

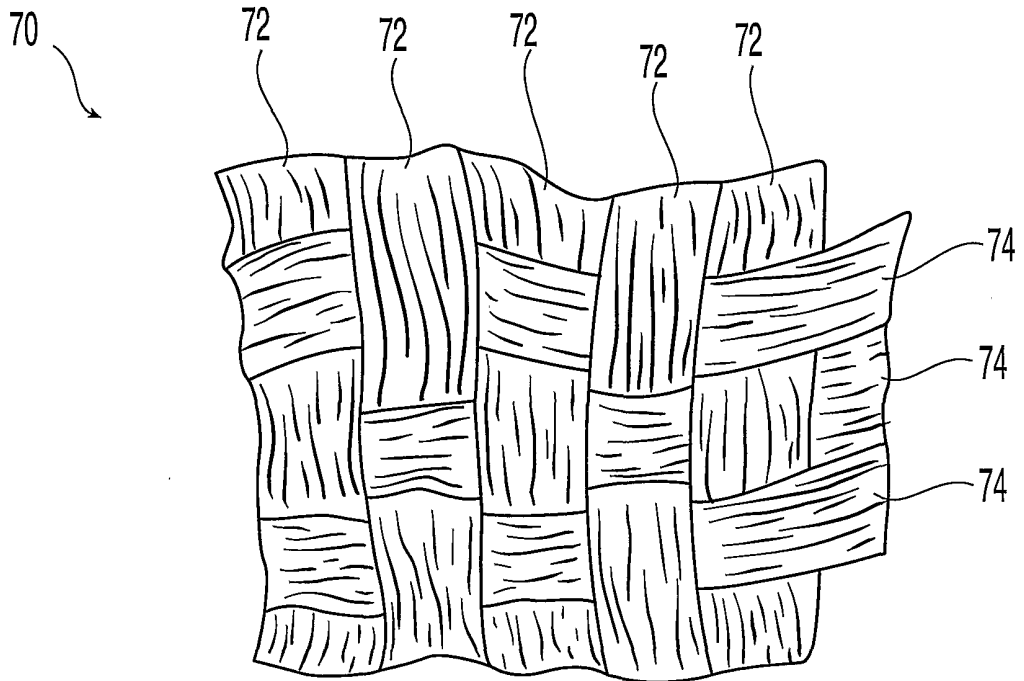

Fig. 11

8/14

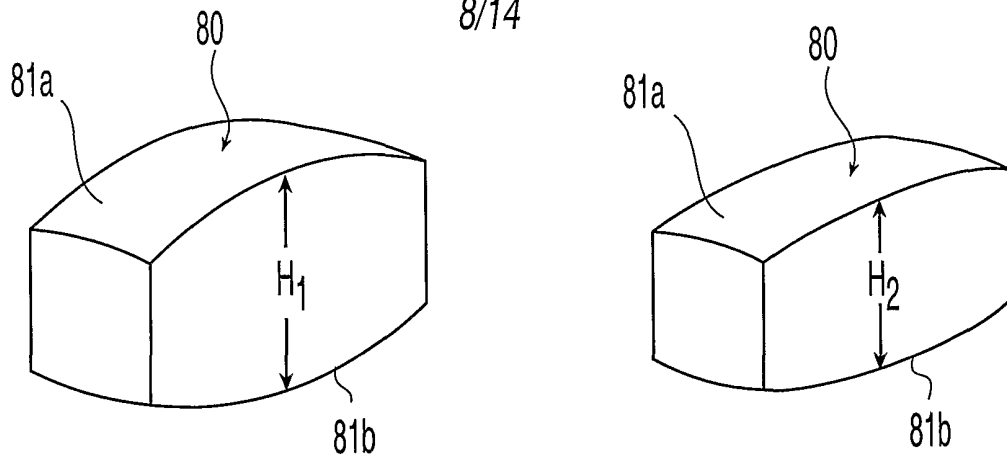

Fig. 12

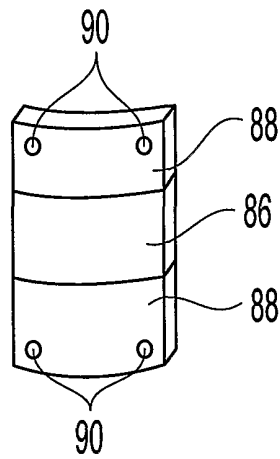

Fig. 14

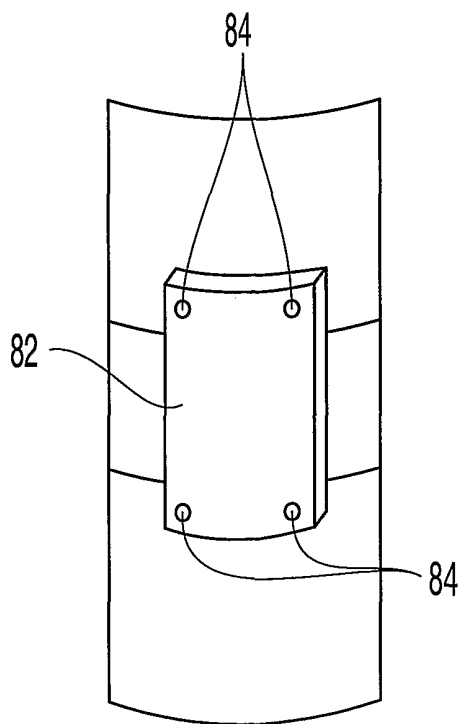

Fig. 13

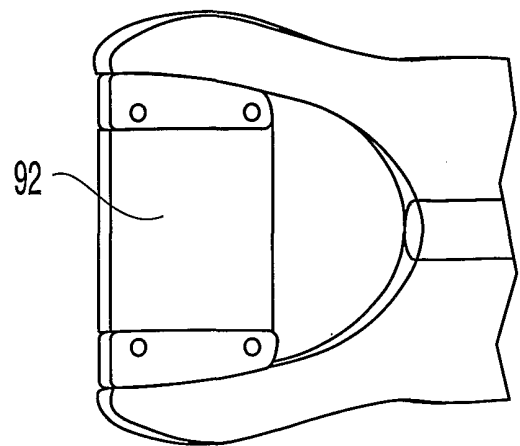

Fig. 15

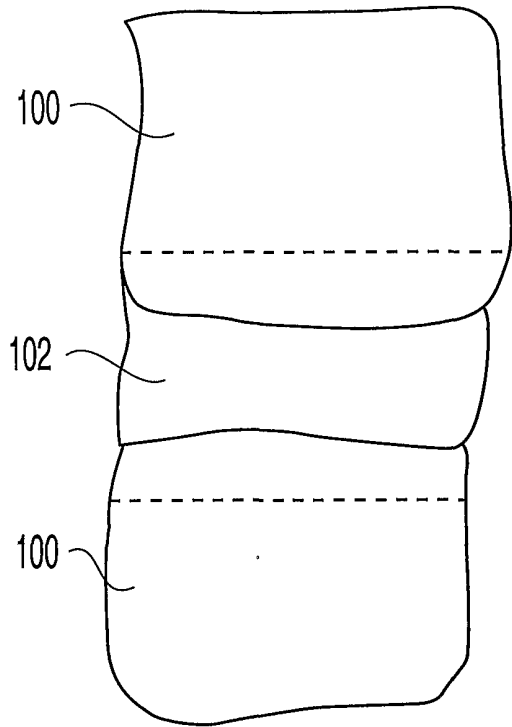

Fig. 16

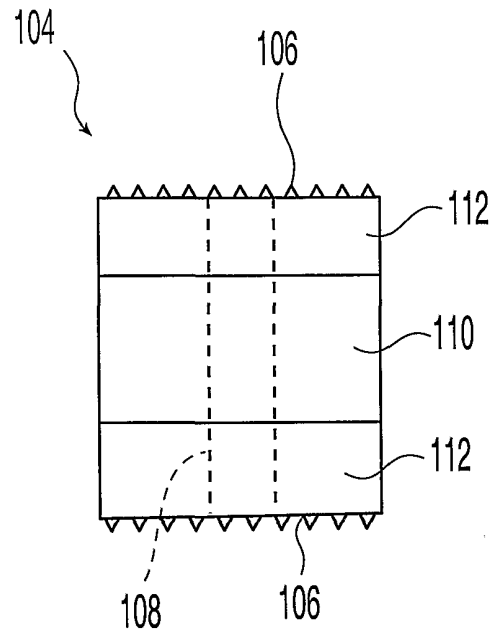

Fig. 17

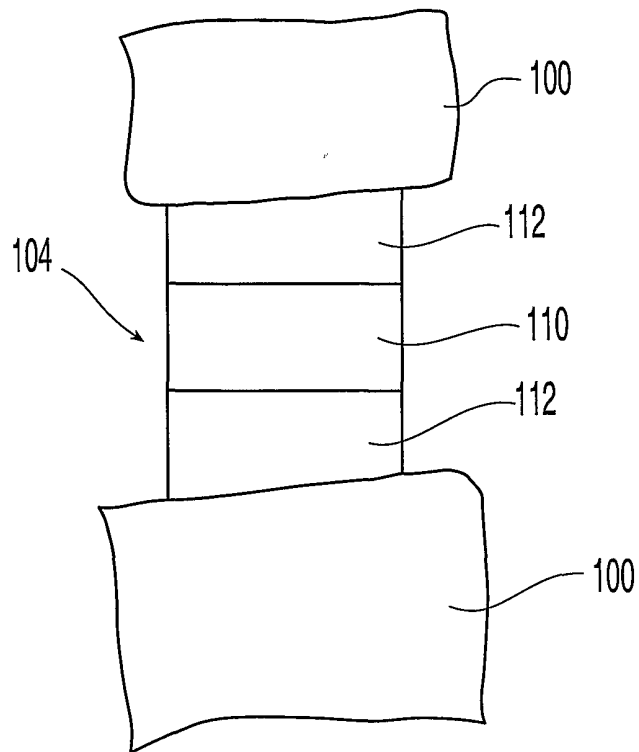

Fig. 18

10/14

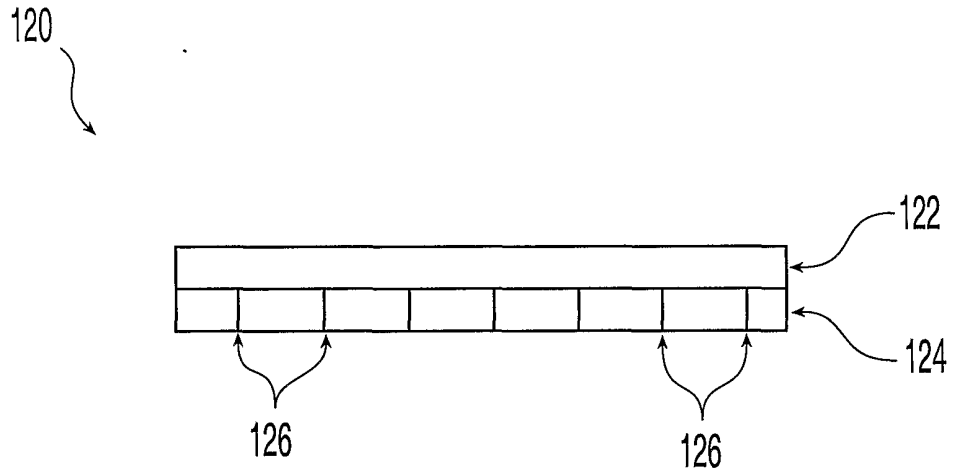

Fig. 19

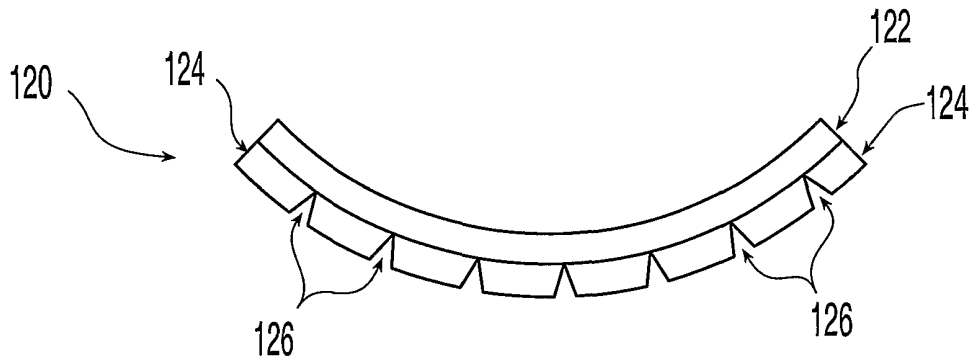

Fig. 20

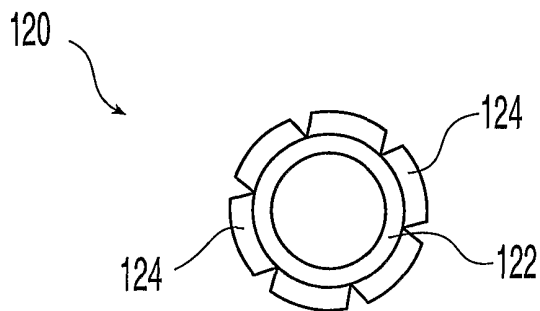

Fig. 21

11/14

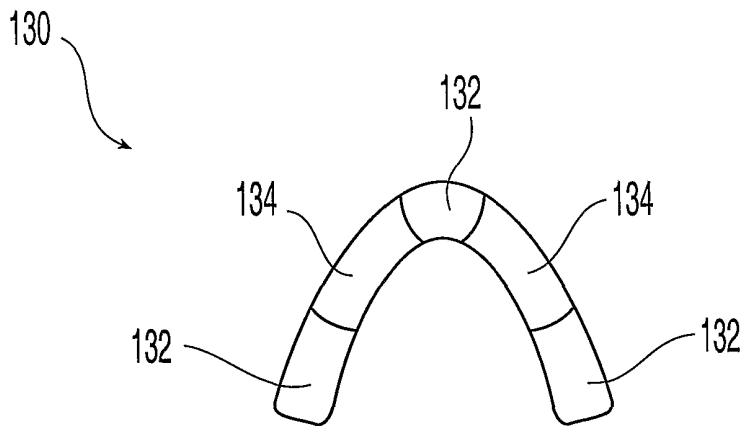

Fig. 22

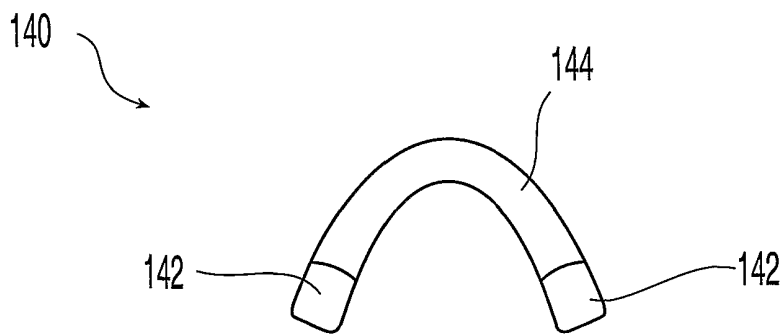

Fig. 23

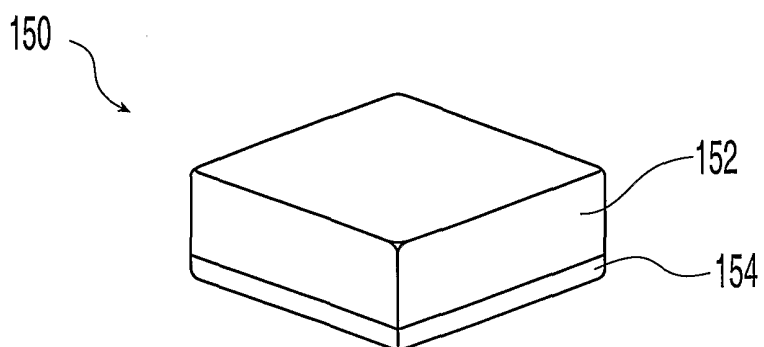

Fig. 24

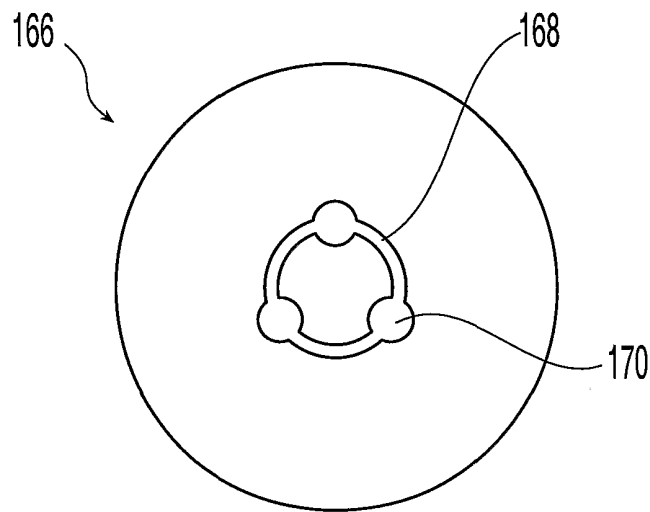
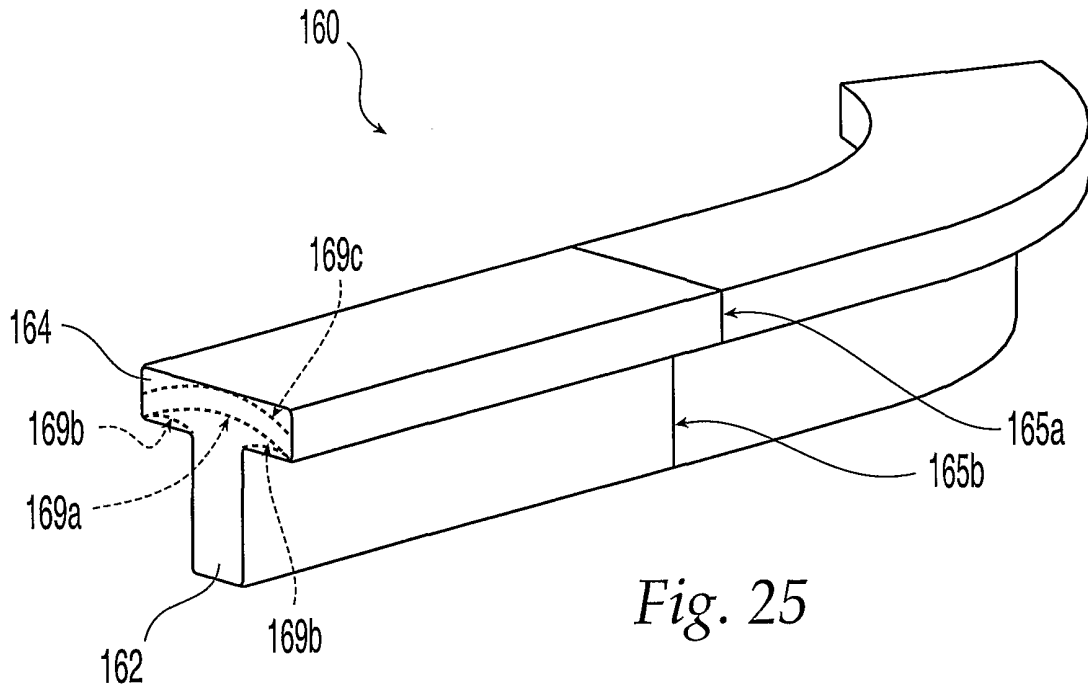

Fig. 26

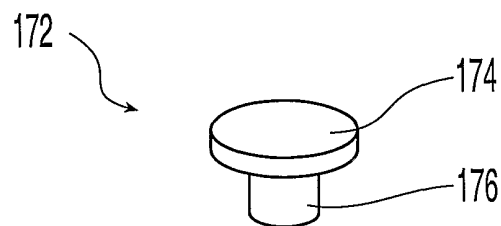

Fig. 27

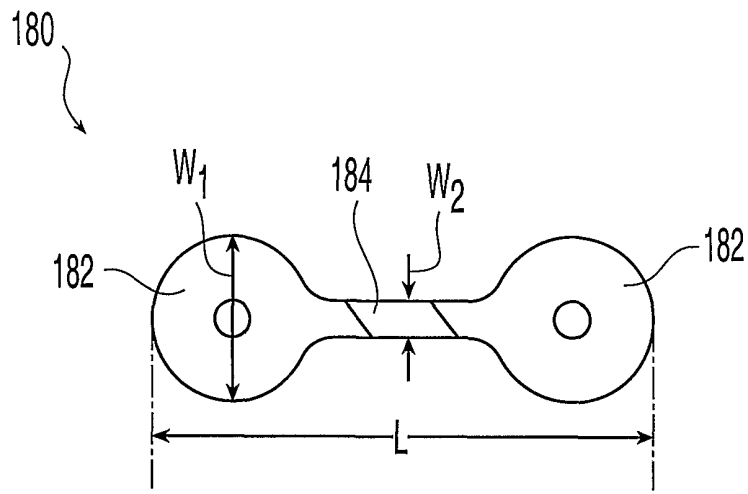

Fig. 28

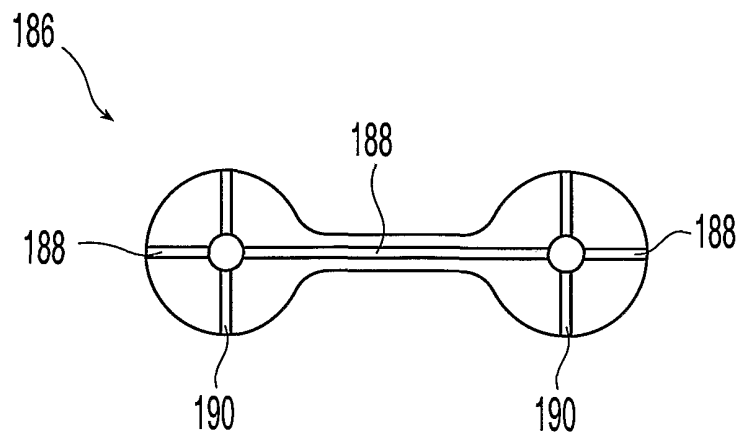

Fig. 29

14/14

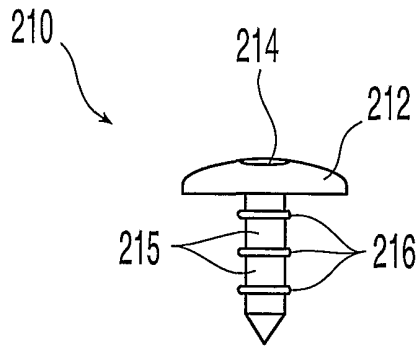

Fig. 30

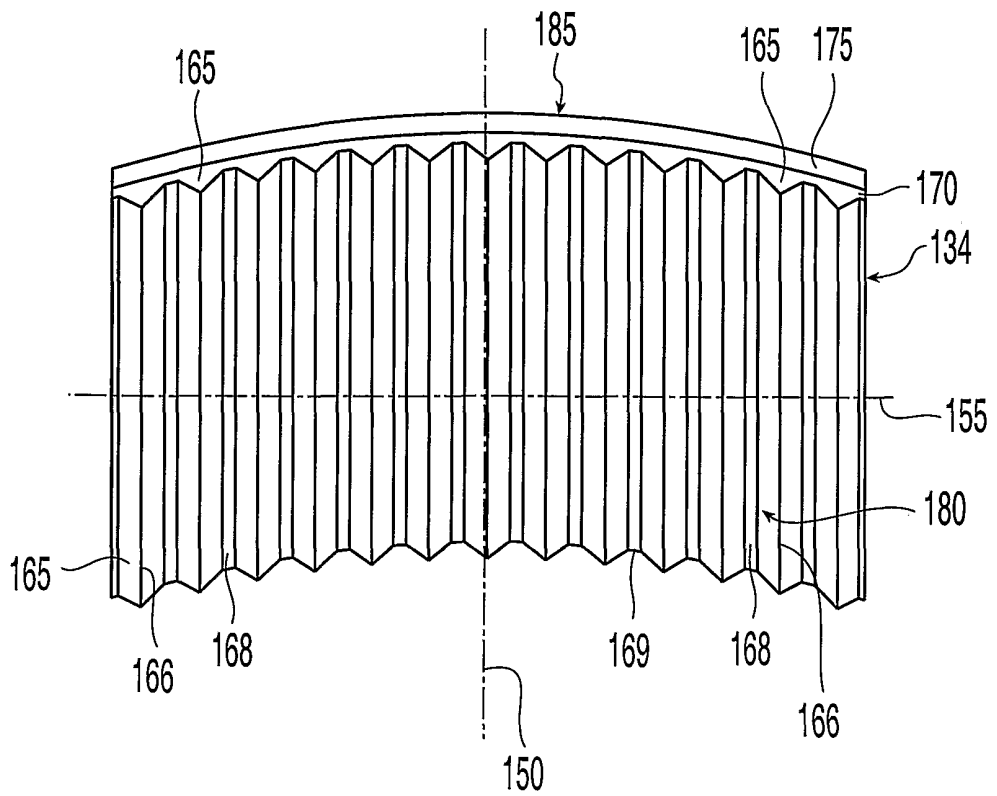

Fig. 31