

(19)



Europäisches Patentamt

European Patent Office

Office européen des brevets



(11)

EP 0 670 138 B1

(12)

EUROPEAN PATENT SPECIFICATION

(45) Date of publication and mention
of the grant of the patent:

14.04.1999 Bulletin 1999/15

(51) Int. Cl.⁶: **A47L 9/24**

(21) Application number: **95850030.8**

(22) Date of filing: **09.02.1995**

(54) Telescopic tube connection for a vacuum cleaner

Teleskopierbare Rohrverbindung für einen Staubsauger

Raccord de tube télescopique pour aspirateur

(84) Designated Contracting States:
DE FR GB

(30) Priority: **01.03.1994 SE 9400702**

(43) Date of publication of application:
06.09.1995 Bulletin 1995/36

(73) Proprietor:
**AKTIEBOLAGET ELECTROLUX
105 45 Stockholm (SE)**

(72) Inventors:
• **Kilström, Lars Gunnar
S-183 30 Täby (SE)**

• **Lindquist, Nils Tommy
S-123 48 Farsta (SE)**
• **Tuvin, Lars Gunnar
S-741 00 Knivsta (SE)**

(74) Representative: **Erixon, Bo et al
c/o AB ELECTROLUX Corporate Patents &
Trademarks
105 45 Stockholm (SE)**

(56) References cited:
EP-A- 0 433 774 EP-A- 0 520 534
WO-A-86/01089 DE-B- 1 236 149
US-A- 3 351 359 US-A- 4 018 493
US-A- 4 422 702

EP 0 670 138 B1

Note: Within nine months from the publication of the mention of the grant of the European patent, any person may give notice to the European Patent Office of opposition to the European patent granted. Notice of opposition shall be filed in a written reasoned statement. It shall not be deemed to have been filed until the opposition fee has been paid. (Art. 99(1) European Patent Convention).

Description

[0001] The present invention relates to a device for a vacuum cleaner having a hose connected between a vacuum cleaner housing and a tube handle, the tube handle being connected to a nozzle by means of a tube shaft. The present invention also relates to hand-held vacuum cleaner units having a vacuum cleaner housing and an inlet tube, the inlet tube being connected to a nozzle by means of a tube shaft.

[0002] Vacuum cleaners are commonly provided with a hose and a tube handle. In order to adapt the length of the tube shaft to the operator, it is common to use tube shafts comprising an inner and an outer tube which can be moved and locked in different positions with respect to each other. Such devices are described, for instance, in EP 293518, 399177, 520534, 552481, 553482 and 537457. However, these devices are difficult to adjust during use because the adjustment mechanism is placed far down on the tube shaft, which means that the operator has to release his grip about the tube handle and use both hands for moving the inner and outer parts of the tube shaft with respect to each other. Moreover, the known tube shaft arrangements can not, in a simple manner, be provided with an electric cable which is joined to the shaft and which connects a motor driven nozzle with the electric source of the vacuum cleaner because of the movement between the parts of the tube shaft.

[0003] US-A-4018493 discloses a device for a vacuum cleaner according to preamble of claim 1.

[0004] Recently a new type of vacuum cleaner comprising a small hand held unit has been developed. This hand-held unit comprises a combination of a vacuum source driven by a high speed electric motor and a dust container which is connected directly to a tube shaft. This type of vacuum cleaners is described for instance in PCT/SE94/00002 and PCT/SE94/00003.

[0005] An object of the present invention is to provide a simple and cheap telescopic device for the types of vacuum cleaners mentioned above. The device according to the invention allows a comfortable adjustment of the length of the tube shaft and the adjustment can be effected during use of the vacuum cleaner without making it necessary for the operator to completely change the grip of the handle or the tube shaft. The arrangement also makes it possible to place an electric cable directly on the tube shaft and, in a simple way connect the cable to a motor driven nozzle and to another electric cable placed on the hose. This is achieved by means of a device having the characteristics mentioned in the claims.

[0006] An embodiment of the invention will now be described with reference to the accompanying drawings in which: Fig. 1, in a side view, shows the nozzle of a vacuum cleaner with associating parts according to the invention; Fig. 2, in a larger scale, shows the connection between the tube shaft of the vacuum cleaner and the

tube handle.

[0007] With reference to the drawing figures, a vacuum cleaner nozzle 10, for instance a motor driven nozzle, is shown to be connected, via a tube shaft 11, to a tube handle 12. The tube handle 12 is, as usual, connected to one end of a hose 13 whose other end is connected to a vacuum cleaner housing (not shown) which comprises a dust container and a motor-fan unit.

[0008] The tube handle 12 comprises a front part 14 which is directed obliquely downwards towards the nozzle and which is inserted into the tube shaft 12. The front part has several recesses 15 the purpose of which will be discussed below. A rear part 16 of the tube handle is shaped as a handle whereas an intermediate section 17 has control means 18, if any, for the vacuum cleaner and an electric socket 19. The electric socket is connected to the household electric supply via an electric cable extending through the handle, hose and vacuum cleaner housing connected to the electric main supply.

[0009] The tube shaft 11, which has a diameter that is somewhat larger than the diameter of the front part 14 of the tube handle, is telescopically slidable on the tube handle and has, at its upper end, a collar-shaped section 20 which contains a locking means 21. This locking means is of conventional type and cooperates with the recesses 15 in such a way that the tube shaft 11 can be fixed in different positions on the tube handle 12, corresponding to the positions of the recesses. The tube shaft also comprises an electric cable 22 which is placed in a shell 23 at the outside of the tube shaft. The electric cable at the lower part of the tube shaft may (in a way not shown in detail) be arranged to automatically be connected to a corresponding means on the nozzle when the nozzle is fastened to the tube shaft.

[0010] The upper part of the cable 22 is shaped as an elastic coil 24 to which a plug 25 is connected. This plug can be connected to the socket 19, but is normally stored in a holder 26 in the upper part of the tube shaft, and the coil 24 is stored in a pocket in the holder. It should be mentioned that it is also possible to place the coil 24 at a lower part of the cable and to use an upper linear cable section extending out from the holder when the plug is connected to the socket. In such a case, the pocket in the holder, of course, has to be somewhat extended in the downward direction.

[0011] The device is used in the following way. A conventional nozzle 10 or a motor driven nozzle is connected to the lower part of the tube shaft 11 after which the tube handle 12 is inserted into the tube shaft 11 and is fixed in position by means of the locking mechanism 21. If necessary, the plug 25 is pulled out, together with the coil 24, from the holder 26 and is connected to the socket 19 on the tube handle 12. When the vacuum cleaner is being used, the operator with one hand grasps the handle 16 and with the other hand grasps the upper part of the tube shaft 11. If it is necessary to adjust the length of the tube shaft during use in order to

get a comfortable working position, the lower hand is moved slightly up towards the locking means 21 and activates it so that the tube shaft can be telescopically moved with respect to the tube handle thereby maintaining the grip of the upper hand. If the plug 25 is connected to the socket 19, the electric cable 22 during this telescopic movement 22, is still connected to the vacuum cleaner housing because of the flexibility of the coil 24. Thus, the adjustment is very easy to do.

[0012] By means of the suggested arrangement, the advantage is also achieved that the tube shaft, even if it has a fixed shape which allows an electric cable in a simple way to be arranged outside the tube shaft, together with the tube handle offers a possibility to adjust the distance between the nozzle and the handle.

[0013] It should be observed that it is within the scope of the invention to invert the arrangement i.e. to place the locking means on the tube shaft and to let the tube shaft move within the tube handle as well as it is possible to use other types of locking mechanisms such as, for instance, mechanisms wherein locking is achieved by turning a part of the tube shaft or the tube handle.

[0014] It is also possible within the scope of the invention to integrate the vacuum cleaner housing and the tube handle to a hand held unit with an inlet tube which corresponds to the front part 14 of the tube handle 12 of this unit in a corresponding way being movable with respect to the tube shaft.

Claims

1. A device for a vacuum cleaner comprising a hose (13), a tube handle (12), and a tube shaft (11), said hose having a first end connected to a vacuum cleaner housing and a second end connected directly to a first end of said tube handle, said tube handle having a second end directly connected to a first end of said tube shaft (11), said tube shaft having a second end which is secured to a nozzle (10), **characterized in** that the first end of the tube shaft (11) is telescopically movably connected to the second end of the handle (12), and in that said tube handle (12) and said tube shaft (11) are provided with means (21,15) for locking the tube shaft in several different positions with respect to the tube handle.
2. A device for a hand held vacuum cleaner comprising a vacuum cleaner housing with an inlet tube which is connected to a nozzle or the like by means of a tube shaft, said inlet tube and being directly connected to said tube shaft, **characterized in** that the tube shaft is telescopically movable relative to the inlet tube, and in that said inlet tube and tube shaft are provided with means for locking the tube shaft in several different positions with respect to the inlet tube.

3. Device according to claim 1 or 2, **characterized in** that the tube handle (12), the inlet tube or the tube shaft (11) are provided with several recesses (15) or the like.
4. Device according to any of the preceding claims, **characterized in** that an electric cable (22) is fixed on the tube shaft (11), the upper end of the cable being provided with a plug (25) for connection to a socket (19) arranged on the tube handle (12) or on the inlet tube .
5. Device according to claim 4, **characterized in** that the electric cable (22) is provided with a coil shaped part (24).
6. Device according to claim 4 or 5, **characterized in** that the upper end of the electric cable (22), when not being used, is placed in a holder (26) arranged on the tube shaft.
7. Device according to any of claims 4-6, **characterized in** that the electric cable (22) is placed outside the tube shaft (11).
8. Device according to any of claims 6 or 7, **characterized in** that the holder (26) is provided with a pocket in which the coil shaped part (24) of the electric cable normally is stored.

Patentansprüche

1. Vorrichtung für einen Staubsauger umfassend einen Schlauch (13), einen Rohrgriff (12) und einen Rohrschaft (11), wobei der Schlauch mit einem ersten Ende mit einem Staubsaugergehäuse verbunden ist und mit einem zweiten Ende direkt mit einem ersten Ende des Rohrgriffes verbunden ist, wobei der Rohrgriff mit einem zweiten Ende direkt mit einem ersten Ende des Rohrschaftes (11) verbunden ist, wobei der Rohrschaft ein zweites Ende hat, das an einer Düse (10) befestigt ist, dadurch gekennzeichnet, daß das erste Ende des Rohrschaftes (11) teleskopisch beweglich mit dem zweiten Ende des Rohrgriffes (12) verbunden ist, und daß der Rohrgriff (12) und der Rohrschaft (11) mit einer Einrichtung (21, 15) zum Verriegeln des Rohrschaftes in mehreren unterschiedlichen Positionen zu dem Rohrgriff versehen ist.
2. Vorrichtung für einen handgehatenen Staubsauger umfassend ein Staubsaugergehäuse mit einem Einlaßrohr, das mit einer Düse oder ähnlichem mittels eines Rohrschaftes verbunden ist, wobei das Einlaßrohr direkt mit dem Rohrschaft verbunden ist, dadurch gekennzeichnet, daß der Rohrschaft teleskopisch relativ zu dem Einlaßrohr beweglich ist, und daß das Einlaßrohr und der Rohrschaft mit

einer Einrichtung zum Verriegeln des Rohrschaftes in mehreren unterschiedlichen Positionen zu dem Einlaßrohr versehen sind.

3. Vorrichtung nach Anspruch 1 oder 2, dadurch gekennzeichnet, daß der Rohrgriff (12), das Einlaßrohr oder der Rohrschaft (11) mit mehreren Ausparungen (15) oder ähnlichem versehen sind. 5
4. Vorrichtung nach einem der vorhergehenden Ansprüche, dadurch gekennzeichnet, daß ein elektrisches Kabel (22) an dem Rohrschaft (11) fixiert ist, wobei das obere Ende des Kabels mit einem Stecker (25) für das Verbinden mit einer Buchse (19) versehen ist, die an dem Rohrgriff (12) oder an dem Einlaßrohr angeordnet ist. 10 15
5. Vorrichtung nach Anspruch 4, dadurch gekennzeichnet, daß das elektrische Kabel (22) mit einem spulenförmigen Teil (24) versehen ist. 20
6. Vorrichtung nach Anspruch 4 oder 5, dadurch gekennzeichnet, daß das obere Ende des elektrischen Kabels (22), wenn es nicht verwendet wird, in einem Halter (28) positioniert ist, der an dem Rohrschaft angeordnet ist. 25
7. Vorrichtung nach einem der Ansprüche 4 bis 6, dadurch gekennzeichnet, daß das elektrische Kabel (22) außerhalb des Rohrschaftes (11) positioniert ist. 30
8. Vorrichtung nach einem der Ansprüche 6 oder 7, dadurch gekennzeichnet, daß der Halter (26) mit einer Tasche versehen ist, in die der spulenförmige Teil (24) des elektrischen Kabels normalerweise gelagert ist. 35

Revendications

1. Dispositif destiné à un aspirateur comprenant un tuyau (13), une poignée tubulaire (12) et un corps de tube (11), ledit tuyau ayant une première extrémité connectée à un corps d'aspirateur et une seconde extrémité connectée directement à une première extrémité de ladite poignée tubulaire, ladite poignée tubulaire comportant une seconde extrémité connectée directement à une première extrémité dudit corps de tube (11), ledit corps de tube comportant une seconde extrémité qui est fixée à une buse d'aspiration (10), caractérisé en ce que la première extrémité du corps de tube (11) est connectée de manière mobile et télescopique à la seconde extrémité de la poignée tubulaire (12), et en ce que ladite poignée tubulaire (12) et ledit corps de tube (11) comportent des moyens (21, 15) destinés à bloquer le corps de tube dans plusieurs positions différentes par rapport à la poignée tubu- 40 45 50 55

laire.

2. Dispositif destiné à un aspirateur portable comprenant un corps d'aspirateur comportant un tube d'admission qui est connecté à une buse d'aspiration ou similaire au moyen d'un corps de tube, ledit tube d'admission étant connecté directement au dit corps de tube, caractérisé en ce que le corps de tube est mobile de manière télescopique par rapport au tube d'admission, et en ce que ledit tube d'admission et ledit corps de tube comportent des moyens destinés à bloquer le corps de tube dans plusieurs positions différentes par rapport au tube d'admission.
3. Dispositif selon la revendication 1 ou la revendication 2, caractérisé en ce que la poignée tubulaire (12), le tube d'admission ou le corps de tube (11) comportent plusieurs retraits (15) ou similaire.
4. Dispositif selon l'une quelconque des revendications précédentes, caractérisé en ce qu'un câble électrique (22) est fixé sur le corps de tube (11), l'extrémité supérieure du câble comportant une prise (25) destinée à être connectée à un socle de prise (19) disposé sur la poignée tubulaire ou sur le tube d'admission.
5. Dispositif selon la revendication 4, caractérisé en ce que le câble électrique (22) comporte une partie en forme de spirale (24).
6. Dispositif selon la revendication 4 ou la revendication 5, caractérisé en ce que l'extrémité supérieure du câble électrique (22), lorsqu'elle n'est pas utilisée, est remise dans un support (26) aménagé sur le corps de tube.
7. Dispositif selon l'une quelconque des revendications 4 à 6, caractérisé en ce que le câble électrique (22) est placé à l'extérieur du corps de tube (11).
8. Dispositif selon l'une quelconque des revendications 6 ou 7, caractérisé en ce que le support (26) comporte une poche dans laquelle est remise de manière normale la partie en forme de spirale (24) du câble électrique.

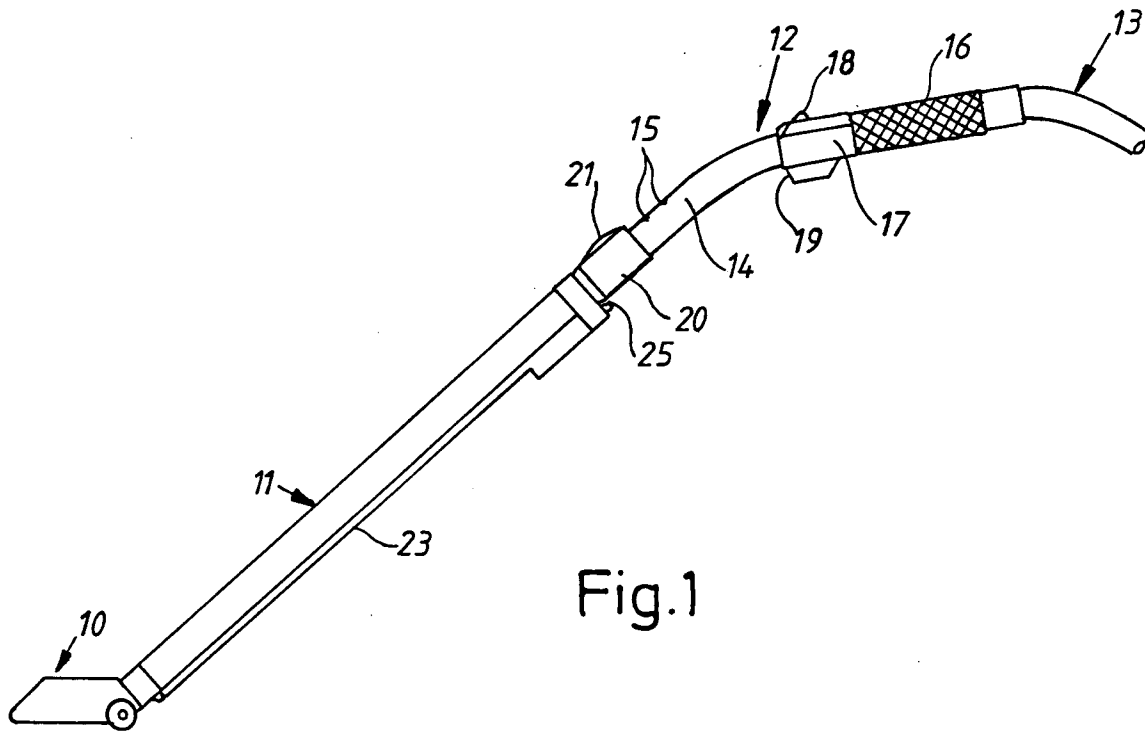

Fig. 1

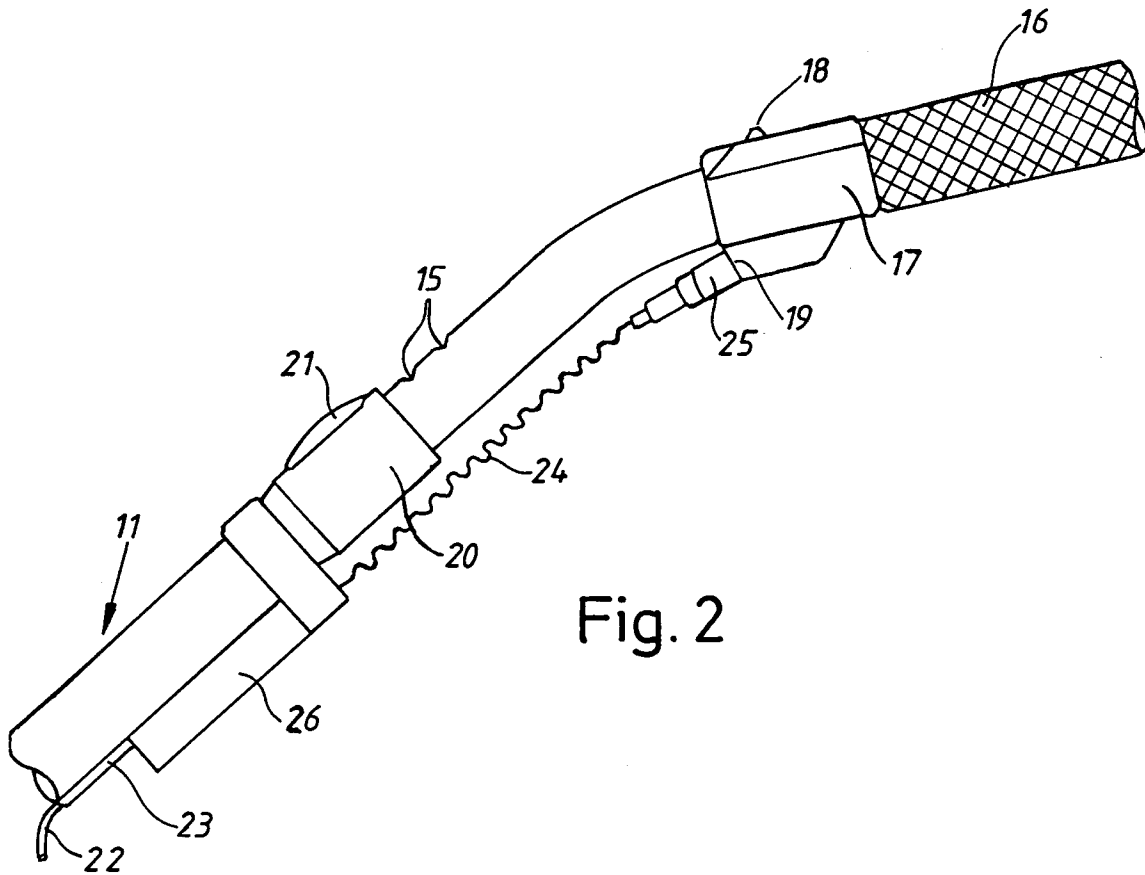

Fig. 2