

June 22, 1926.

1,589,974

J. L. LANE

FUSE

Filed May 19, 1924

Fig. 1.

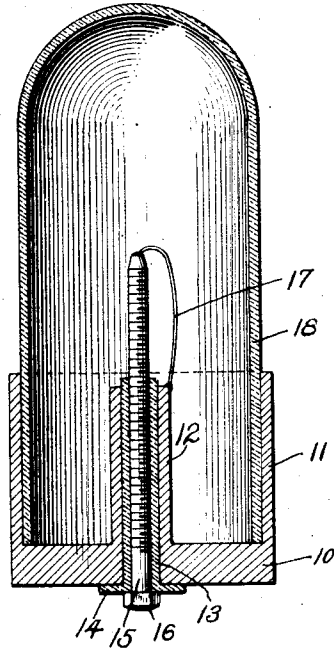

Fig. 2.

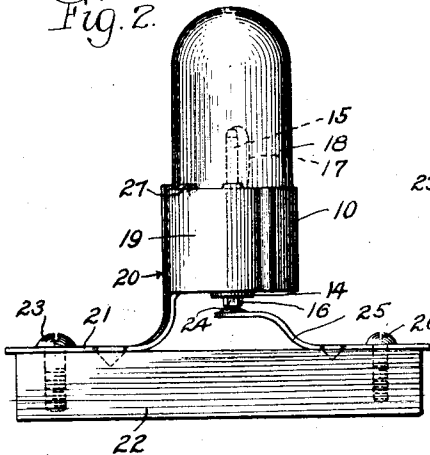
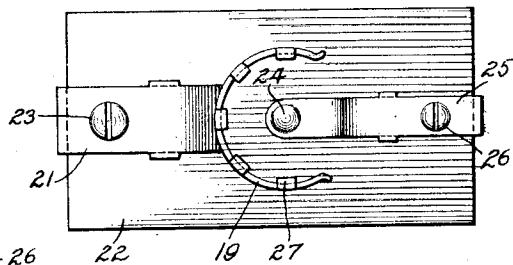

Fig. 3.



Inventor:

James Leslie Lane,

By *Clindahl, Parker & Carlson*  
Attys.

# UNITED STATES PATENT OFFICE.

JAMES LESLIE LANE, OF CHICAGO, ILLINOIS, ASSIGNOR TO CHICAGO FUSE MFG. COMPANY, OF CHICAGO, ILLINOIS, A CORPORATION OF ILLINOIS.

## FUSE.

Application filed May 19, 1924. Serial No. 714,217.

My invention relates to improvements in electrical fuses, and has for its main object the provision of a fuse adapted for small currents, such as are utilized in radio receiving sets.

Another object is to provide a fuse which is simple and artistic in construction, and which is provided with a transparent enclosing member such that a blow can be easily detected by casual inspection, thereby adapting the fuse to the protection of radio electron tubes and other delicate electrical devices.

A further object is to provide a fuse unit comprising a removable cartridge fuse, and a novel mounting having a special clip adapted to support the cartridge and retain it in good electrical contact.

Further objects and advantages will become apparent as the description proceeds.

In the drawings, Figure 1 is a vertical section of a cartridge fuse embodying the features of my invention.

Fig. 2 is a side view in elevation of the cartridge fuse and its mounting.

Fig. 3 is a plan view of the mounting.

In the exemplary embodiment illustrated in the drawings, 10 represents a metallic head preferably constructed of brass and having a long cylindrical flange 11. A sleeve 12 is formed integral with the head 10, and extends concentrically through the flange 11. Extending through the sleeve 12 is an insulating bushing 13 made of any suitable material, and having a peripheral flange 14 on its lower end abutting against the face of the head 10. A contact screw 15 having a head 16 fitting against the flange 14 is threaded completely through the insulating bushing 13. A fuse element 17 is electrically connected at its opposite ends to the sleeve 12 and the upper end of the screw 15. The head 10 and the head 16 thus constitute the two contacts of the cartridge fuse. To enclose and protect the fuse element 17, a transparent tube or globe 18 closed at its upper end is removably mounted in the flange 11 in telescoping relation. It will be seen that the construction thus far described is simple and inexpensive, and that the fuse element 17 can be easily and quickly replaced or renewed, and is wholly exposed to view. This last feature is advantageous where small currents are employed and the blow is light and unnotice-

able, since the condition of the fuse element 17 can be observed by a casual glance.

To support the fuse cartridge, the head 10 is adapted to be forced into yielding engagement with a pair of spaced spring arms 19 formed on a clip 20. This clip constitutes one contact of the fuse mounting, and is provided with a metallic strip 21 which is secured to a base board 22 by a screw 23, and is adapted to be connected with an electric lead wire (not shown) in any well known manner. Underlying the arms 19 is a contact 24 mounted on the free end of a spring leaf 25 to engage the head 16 when the cartridge is clamped in place. The leaf 25 is secured to the board 22 by a screw 26, and is also adapted to be connected with a lead wire (not shown). To prevent the head 16 from moving vertically out of engagement with the contact 24, the arms 19 are formed with a plurality of lugs 27 bent inwardly to fit over the upper edge of the sleeve 11.

While I have described the preferred embodiment of my invention with considerable particularity for purposes of illustration, it is to be understood that I do not thereby intend to limit the same but aim in the subjoined claims to cover all modifications and alternative constructions falling within its spirit and scope.

I claim as my invention:

1. A fuse comprising, in combination, a metallic head having a cylindrical flange and an integral sleeve extending concentrically into said flange, said head constituting one contact of the fuse, an insulating bushing extending through said sleeve and having a peripheral flange on one end fitting against the face of said head, a contact screw threaded through said sleeve and having a head fitting against said peripheral flange and constituting the other contact of the fuse, a fuse element connected to the inner end of said screw and to said cylindrical flange, and a glass tube closed at its outer end and fitting over said fuse element into telescoping relation with said cylindrical flange.

2. A fuse comprising, in combination, a cylindrical head having a concentric sleeve constituting one contact of the fuse, an insulating bushing in said sleeve, a contact member extending through said sleeve and having a head on one end constituting the

other contact of the fuse, a fuse element secured to the other end of said contact member and to said sleeve, and a transparent globe fitting over said fuse element and into said head.

3. A fuse comprising, in combination, a head having a cylindrical flange and a concentric sleeve, said head constituting one contact of the fuse, an insulating bushing in said sleeve, a contact member extending through said bushing and having a head on one end constituting the other contact of the fuse, a fuse element attached to the other end of said member and to said sleeve, and a globe engaging said cylindrical flange and enclosing said fuse element.

4. A fuse comprising, in combination, a transparent globe open at one end, a metallic head closing the end of said globe and having a cylindrical flange fitting around said open end to provide an outer peripheral contact, a pin insulated from and extending through said head into said globe, the outer end of said pin providing the other fuse contact, and a fuse element joining the inner end of said pin and said metallic head.

5. A fuse comprising, in combination, a base board, a metallic clip mounted on said board and having a pair of spaced spring arms, a metallic head clamped between said arms, an insulating bushing extending through said head, a metallic pin extending through said bushing, a fuse element secured to one end of said pin and to said head, a transparent globe enclosing said fuse element, a contact underlying said spring arms and engaging the other end of said pin, and a spring leaf mounted on said board and supporting said last mentioned contact.

6. A fuse comprising, in combination, a base board, a spring clip secured to said board and having a pair of spaced spring arms, a metallic head clamped between said arms, an insulating bushing extending through said head, a central contact member extending through said bushing, a fuse ele-

ment secured at its opposite ends to one end of said contact member and to said head, means for enclosing said fuse element, a contact mounted on said board below said arms in engagement with the other end of said member, and a plurality of lugs formed on the one edge of said arms and bent inwardly to fit over one edge of said head to hold the latter in place.

7. A mounting for fuses comprising, in combination, a base, a metallic clip secured to said base and having a pair of spaced spring arms adapted to receive the fuse, a central contact secured to said base and positioned centrally below said arms to engage one end of the fuse, and a plurality of lugs formed on the remote edge of said arms and bent inwardly to prevent longitudinal movement of the fuse away from said contact.

8. A mounting for fuses comprising, in combination, a base board, a metallic clip having a pair of spaced spring clamping members adapted to receive the contact head of the fuse, a spring leaf mounted on said board and having a contact on its free end, said contact being positioned beneath said arms to engage the central contact of the fuse, and a plurality of lugs formed on said arms and bent inwardly to engage one edge of the head to hold the latter against longitudinal movement away from said first mentioned contact.

9. An electrical fuse unit comprising, in combination, a base board, a pair of opposed spring arms supported above said base board, a contact member mounted on said base board and underlying said spring arms, and a fuse cartridge provided at one end with an outer peripheral contact and a central contact, said last mentioned contact being engaged by said contact member when said peripheral contact is clamped between said spring arms.

In testimony whereof, I have hereunto affixed my signature.

JAMES LESLIE LANE.