

(19)



(11)

**EP 1 055 878 B1**

(12)

**EUROPEAN PATENT SPECIFICATION**

(45) Date of publication and mention of the grant of the patent:  
**03.10.2007 Bulletin 2007/40**

(51) Int Cl.:  
**F23Q 7/00 (2006.01)**

(21) Application number: **00110503.0**

(22) Date of filing: **17.05.2000**

(54) **Glow plug and method for producing same**

Glühkerze und Verfahren zum Herstellung derselben

Bougie à incandescence et son procédé de fabrication

(84) Designated Contracting States:  
**DE FR GB**

(30) Priority: **27.05.1999 JP 14881099**  
**28.02.2000 JP 2000056057**

(43) Date of publication of application:  
**29.11.2000 Bulletin 2000/48**

(73) Proprietor: **DENSO CORPORATION**  
**Kariya-city,**  
**Aichi-pref. 448-8661 (JP)**

(72) Inventor: **Watanabe, Tetsuya,**  
**c/o Intellectual Property Dept.**  
**Kariya-city,**  
**Aichi-pref 448-8661 (JP)**

(74) Representative: **TBK-Patent**  
**Bavariaring 4-6**  
**80336 München (DE)**

(56) References cited:  
**EP-A- 0 602 745** **GB-A- 960 265**

**EP 1 055 878 B1**

Note: Within nine months from the publication of the mention of the grant of the European patent, any person may give notice to the European Patent Office of opposition to the European patent granted. Notice of opposition shall be filed in a written reasoned statement. It shall not be deemed to have been filed until the opposition fee has been paid. (Art. 99(1) European Patent Convention).

## Description

**[0001]** The present invention relates to a glow plug for improving the startability of a diesel engine, or other devices, and a method for producing the same.

### 2. Description of the Related Art

**[0002]** EP-A-0 602 745 discloses a glow plug for diesel engines comprising a tubular metal sheath, which contains a dual coil electric resistance embedded in a compacted electrically insulating and thermally conductive powder-material. The two coils of the resistance are made with wires of the same material.

**[0003]** Another glow plug is disclosed in Japanese Unexamined Patent Publication (Kokai) No. 9-217933. This glow plug comprises a tube (sheath) and a resistor embedded in an insulating powder contained in the interior of the tube, wherein the resistor is wound in a spiral shape on a winding axis corresponding to a longitudinal axis of the tube. The resistor is energized with a current to generate heat.

**[0004]** This glow plug is usually produced by placing the resistor in the tube and, after filling an insulating powder in the interior of the tube, swaging the tube to increase the filling density of the insulating powder.

**[0005]** During the swaging process, the resistor is subjected to a compressive force applied in the direction vertical to the axis on which the spiral is wound. Since the resistor is wound in a spiral shape about the longitudinal axis of the tube as described above, the resistor is compressed in the axial direction of resistor wire, whereby the resistor becomes thicker in diameter due to this compressive force to decrease its resistance. This is contradictory to the requirement in that the resistor must have a large resistance value to act as a heater.

**[0006]** The present inventors have tried to solve this problem from the view point that the increase in diameter of the resistor due to swaging could be minimized by tilting the resistor relative to the winding axis of the spiral so that the wire axis of the resistor wound in a spiral shape largely deviates from the direction of the compressive force generated due to the swaging.

**[0007]** In this regard, the spiral shape of the conventional resistor J is shown in Fig. 2(a). A distance between a first point t1 and a second point t2 measured in the direction of an axis M about which the resistor is wound defines a spiral pitch P. Note that the axis M is an imaginary line.

**[0008]** Also, a third point t3 is defined on the resistor J intermediate between the first and second points at a position apart half a length of the resistor between the first and second points from the first point. A distance Q between the third point and the first point measured in the winding direction is a so-called half spiral pitch which is 1/2 of the spiral pitch.

**[0009]** A compressive force is applied to the resistor J in the direction vertical to the winding direction, which is

generated due to the swaging, as shown in the arrowed direction R as shown in Fig. 2(a). Accordingly, the resistor J collapses in the wire-axial direction as shown in Fig. 2 (b) to result in an increase in the wire diameter.

**[0010]** To cause the wire axis of the resistor to largely deviate from the direction in which the compressive force is applied, it is believed effective to widen the spiral pitch. As described in the above-mentioned publication, when part of the resistor is arranged parallel to the winding axis, the compressive force even if it exists would not increase the wire diameter. However, such a parallel arrangement of part of the resistor to the winding axis lessens the number of windings of the resistor in a definite space to fail to allow achievement of the desired resistance value.

**[0011]** Contrary to this, as shown in Fig. 3, when the resistor 4, 5 is tilted to the imaginary winding axis M, the larger the tilting angle, the larger the deflection of the wire axis of the resistor from the direction in which the compressive force is applied to the resistor, without being accompanied with a reduction in the winding number. Such a tilting arrangement causes the distance Q between the third point t3 and the first point t1 as measured in the direction of winding axis M to be larger than 1/2 of the spiral pitch P.

**[0012]** The inventors have studied to find how spiral shape of the resistor should be tilted relative to the winding axis for purpose of properly restricting the variation in resistance of the resistor due to swaging. As a result, as shown in Fig. 6, it has been found that there is a certain inclination range of the resistor wherein the difference in resistance between before and after swaging is significantly minimized. The present invention is based on this knowledge.

### SUMMARY OF THE INVENTION

**[0013]** An object of the present invention is to provide a glow plug capable of restricting the resistance variation of a resistor caused by the swaging of a tube and a method of producing the same.

**[0014]** This object is solved by a glow plug according to claim 1.

**[0015]** According to one aspect of the present invention, provision is made of a glow plug, comprising a hollow tube (3) and a resistor (4, 5) retained in the tube while being wound in a spiral shape having a winding axis (M) coinciding with a longitudinal axis of the tube, the resistor being heated by being energized with a current, characterized in that a third point (t3) is defined at a position along the resistor between a first point (t1), and a second point (t2) defining a spiral pitch (P) of the resistor; the third point being distant from the first point and close to the second point (t2) at half the distance between the first point and the second point along the resistor; and in that the resistor is inclined relative to the winding axis so that a distance Q between the third point and the first point measured in the direction of the winding axis is 0.75

times the spiral pitch or more; the distance Q being the maximum value relative to the spiral pitch P as the resistor turns 180 degrees on the winding axis (when an imaginary plane K of the resistor rotates 180 degrees).

**[0016]** According to this aspect of the present invention, as shown in Fig. 6, it is possible to provide a glow plug capable of properly restricting the resistance variation of the resistor (4, 5) due to the swaging of the tube (3) wherein the distance Q between the third point (t3) and the first point (t1) measured in the direction of the winding axis (M) is 0.75 times the spiral pitch (P) or more; the distance Q being the maximum value relative to the spiral pitch (P) as the tube (3) turns 180 degrees on the winding axis.

**[0017]** Also, as is apparent from Fig. 2 showing the conventional spiral shape, the third point (t3) which defines half a pitch is alternatively defined as a point located in an imaginary plane (K) containing the first point (t1) and the winding axis (M) at a position opposite to the first point (t1) relative to the winding axis.

**[0018]** Another aspect of the present invention employs the latter definition of the third point (t3), and it is possible to provide a glow plug, capable of properly restricting the resistance variation of the resistor (4, 5) due to the swaging of the tube (3), wherein the distance Q between the third point and the first point (t1) measured in the direction of the winding axis (M) is 0.75 times the spiral pitch (P) or more; the distance Q being the maximum value relative to the spiral pitch P as the resistor turns 180 degrees on the winding axis.

**[0019]** If the distance Q between the third point (t3) and the first point (t1) measured in the direction of the winding axis (M) is equal to the spiral pitch (P) or more (that is, one turn of the spiral pitch or more), it is possible to provide a glow plug capable of properly restricting the resistance variation of the resistor due to the swaging of the tube (3) at a higher level.

**[0020]** The present invention also includes a method for producing a glow plug, mentioned in the preceding aspects, characterized in that the method comprises the steps of preparing a spiral body (100) of a wire material wound about a winding axis (M) to finally form the resistor (4, 5), supporting the circumference of the spiral body with a pair of split jigs (103, 104) arranged opposite to each other relative to the winding axis, pressing the spiral body by moving the pair of split jigs toward each other while translating the pair of split presser jigs in reverse to each other so that the spiral body is tilted relative to the winding axis, and after the spiral body is inserted into the tube (3), swaging the tube along the winding axis.

**[0021]** The present invention may be more fully understood from the description of the preferred embodiments of the invention set forth below, together with the accompanying drawings.

#### BRIEF DESCRIPTION OF THE DRAWINGS

**[0022]** In the drawings,

Fig. 1 is a side sectional view of an overall structure of a glow plug according to one embodiment of the present invention;

Fig. 2 is a schematic illustration of a spiral-shaped resistor of a conventional glow plug;

Figs. 3A and 3B are schematic illustrations, respectively, of a spiral-shaped resistor 4, 5 of the above-mentioned embodiment;

Fig. 4 illustrates a method for producing the glow plug of the above-mentioned embodiment;

Fig. 5 illustrates a modified method for producing the glow plug of the above-mentioned embodiment;

Fig. 6 is a graph illustrating the effect for restricting the resistance variation of the resistor;

Figs. 7A and 7B are schematic side sectional views, respectively, of a glow plug according to other embodiments of the present invention; and

Figs. 8A and 8B are schematic side sectional views, respectively, of a glow plug according to further embodiments of the present invention.

#### DESCRIPTION OF THE PREFERRED EMBODIMENTS

**[0023]** The present invention will be described in more detail below with reference to the embodiments illustrated in the attached drawings. A glow plug 1 shown in Fig. 1 according to the present invention is mounted to each of a plurality of (for example, four) cylinders (not shown) of a diesel engine for facilitating the ignition and combustion of fuel at a starting stage of the engine.

**[0024]** The glow plug 1 includes a hollow housing 2 made of iron type material having a threaded portion 21 for the detachable mounting of the glow plug 1 to the cylinder. An elongate bottomed heater tube (referred to as a tube in this text) 3 with a blocked end 3a and an open end 3b opposite thereto is press-fitted into the housing 2 from one end 2a thereof.

**[0025]** The heater tube 3 is made of electro-conductive material excellent in resistance to heat and oxidation (such as stainless steel) and is located so that the blocked end 3a is exposed from the one end 2a of the housing 2. The heater tube 3 has a smaller-diameter portion 31 on the one end side and a larger-diameter portion 32 on the other end side. The smaller-diameter portion 31 is formed by swaging the outer diameter of the tube.

**[0026]** Coil-shaped first and second resistors (referred to as a resistor in this text) 4 and 5 are provided within the interior of the heater tube 3 along the longitudinal axis thereof. The first resistor 4 is built-in within the heater tube 3 closer to the blocked end 3b and the second resistor 5 is closer to the open end 3b.

**[0027]** The first resistor 4 and the second resistor 5 are formed of a wire wound in a spiral shape about the longitudinal axis of the heater tube 3 while tilting relative to the winding axis, which spiral shape will be described in more detail later.

**[0028]** One end 41 of the first resistor 4 is electrically connected to the blocked end 3a of the heater tube 3,

while the other end 42 of the first resistor 4 is electrically connected to one end 51 of the second resistor 5. The other end 52 of the second resistor 5 is electrically connected by welding or others to one end 61 of an internal shaft 6 made of iron type material fixedly inserted into the housing 2.

**[0029]** A portion of the internal shaft 6 closer to the one end 61, the first resistor 4 and the second resistor 5 are embedded in an insulating powder 30 of a heat-resistant and insulating material (such as magnesia) filled within the heater tube 3. Thereby, the portion of the internal shaft 6 closer to the one end 61, the first resistor 4 and the second resistor 5 are insulated from the heater tube 3 except for the blocked end 3a thereof. Note that the insulating powder 30 is sealed at the open end 3b of the heater tube 3 with a seal 33.

**[0030]** The first resistor 4 is made of a first electro-conductive material (for example, iron-chromium alloy or nickel-chromium) having a small rate of change in resistivity (i.e., resistivity at 1000°C/resistivity at 20°C) between a normal temperature (20°C) and 1000°C (a temperature of the first resistor 4 of the glow plug 1 during preheating) such as approximately 1, while the second resistor 5 is made of a second electro-conductive material (for example, nickel, low-carbon steel or cobalt-iron alloy) having the rate of change defined above as large as 5 to 14. In other words, the second electro-conductive material has a larger positive temperature coefficient of resistivity than the first electro-conductive material, wherein the temperature coefficient of resistivity is defined by a tangent of a graph obtained while plotting the measured resistance on the coordinates of which horizontal axis represents the temperature and of which vertical axis represents the resistance.

**[0031]** A fused section 45 connecting the first resistor 4 with the second resistor 5 are formed between both the resistors 4 and 5 by a plasma arc-welding. The fused section 45 is formed by overlapping the other end 42 of the first resistor 4 with one end 51 of the second resistor 5 and applying a plasma arc to the overlapped portion.

**[0032]** A portion of the internal shaft 6 closer to the one end 61 is inserted into the heater tube 3 through the open end 3b, while another portion of the internal shaft 6 closer to the other end 62 is fixedly secured to the other end 2b of the housing 2 in an insulated manner via an O-ring 7 made of electro-insulating material such as fluorine type rubber and a bush 8 made of resin by tightening a nut 9.

**[0033]** According to this glow plug 1, it is possible to supply a large current to the first resistor 4 immediately after the initiation of power supply to heat the first resistor 4. When a predetermined time has lapsed, the resistance of the second resistor 5 increases due to the temperature rise thereof, which in turn causes the power supply to the first resistor 4 to decrease. Thus, the first resistor 4 is prevented from breaking due to the excessive temperature rise.

**[0034]** Next, details of the spiral structure of the first and second resistors 4, 5 used as a resistor of the present

invention will be described with reference to Figs. 2, 3A and 3B. Fig. 2 illustrates a spiral shape of a resistor J of a conventional glow plug of a general type, and Figs. 3A and 3B illustrate a spiral shape of a resistor 4, 5 according to one embodiment of the present invention. Note the first and second resistors 4 and 5 of this embodiment have substantially the same spiral shape.

**[0035]** As shown Fig. 2, the resistor J is of a spiral coil shape depicted on an orthogonal x, y, z coordinates wherein z axis corresponds to the imaginary winding axis M, so that every point on the coil shape or the resistor is represented by F (x, y, z). If represented by a polar coordinates, the following equations are satisfied:

$$x = r \cos \theta, y = r \sin \theta, \text{ and } z = b \theta$$

wherein b is equal to  $P/2\pi$  and r is equal to half a coil diameter (coil outer diameter-wire diameter).

**[0036]** As described before, in Fig. 2, a spiral pitch P is defined as a distance between a first point t1 on the spiral resistor 4, 5 and a second point t2 apart from the first point t1 along the resistor J at an angle  $\theta = 2\pi$  about the winding axis M.

**[0037]** A third point t3 is defined on the resistor J as a point ( $\theta = \pi$ ) which starts from the first point t1 toward the point t2 along the resistor J half an actual length thereof between both the points t1 and t2. In other words, the third point t3 on the resistor J is determined as a middle point of the length of the resistor J between the first point t1 and the second point t2, so that a measured length of the resistor J between the point t1 and the point t3 is equal to that between the point t2 and the point t3.

**[0038]** Also, as described before, the third point t3 may be defined as a point on an imaginary plane K (indicated by a broken line shown in Fig. 2) which starts from the first point t1 toward the point t2 along the resistor J to be positioned opposite to the first position relative to the winding axis M. In the conventional glow plug, the distance Q between the third point 3 and the first point t1 measured in the direction of the winding axis M is in a range from about 0.5 to about 0.74 times the spiral pitch P.

**[0039]** A compressive force generated by the swaging is applied to the resistor J in the direction vertical to the winding axis as shown by an arrow R in Fig. 2. This compressive force causes the resistor J to collapse in the axial direction of the resistor wire to increase the wire diameter. In this regard, the smaller the spiral pitch, the larger the tendency of increase in wire diameter because the orientation of the resistor wire is closer to the vertical to the winding axis.

**[0040]** Contrary to such a conventional resistor J, the resistor 4, 5 of the present invention is of a spiral shape as shown in Figs. 3A and 3B. The example of Fig. 3A is of a clockwise (right-directional) spiral shape as seen in the z-direction (directed from bottom to top in the drawing) in the x, y, z orthogonal coordinates, while that of Fig. 3B is of a counterclockwise (left-directional) spiral as seen

in the z-direction. In both of these spiral shapes, the points t1, t2 and t3, the spiral pitch P, the distance Q, the imaginary winding axis M and the compressive force-application direction R are also defined in the same manner as in Fig. 2.

**[0041]** In the resistor 4, 5 according to this embodiment, the spiral shape is tilted in one direction relative to the winding axis M so that the distance Q is 0.75 times the spiral pitch P or more at a position wherein the distance Q becomes maximum relative to the spiral pitch P as the resistor 4,5 turns 180 degrees on the winding axis M. Thus, the wire axis of the resistor 4, 5 is deflected from the direction R of the compressive force to a larger extent than in the prior art device.

**[0042]** In a state wherein the resistor 4, 5 is tilted in such a manner, as the resistor 4,5 turns 180 degrees about the winding axis M, that is, when the imaginary plane K of the resistor 4, 5 rotates 180 degrees from the state shown in Fig. 3A or 3B on the winding axis M, there is a position wherein the distance Q becomes maximum relative to the spiral pitch P (hereinafter referred to as a position of maximized distance Q). At the position of the maximized distance Q, the following equation is satisfied:

$$Q > 0.75P$$

**[0043]** In the illustrated embodiment, the resistor 4, 5 is tilted in the direction of the winding axis M to such an extent that the distance Q is larger than the spiral pitch P ( $Q > P$ ) at the position of maximized distance Q and the third point t3 is outside a range from the point t1 to the point t2.

**[0044]** The resistor 4, 5 of this embodiment is tilted relative to the winding axis M in one direction so that the distance Q is equal to 0.75 times the spiral pitch P or more. Thus, it is possible to deviate the direction R of the compressive force from the wire axis of the resistor 4, 5 to a larger extent than in the prior art device. In the illustrated embodiment, the resistor 4, 5 is tilted in the direction of the winding axis M to such an extent that the distance Q is larger than the spiral pitch P ( $Q > P$ ) and the third point t3 is outside a range from the point t1 to the point t2.

**[0045]** In this regard, if the distance Q is defined by using the imaginary plane K, it is possible to obtain a spiral shape of the resistor 4, 5 shown in Figs. 3A and 3B, for example, by tilting the spiral relative to the winding axis M so that the second point t2 is closer to the first point t1 and the third point t3 is away from the first point t1 in the direction of the winding axis M in the imaginary plane K shown in Fig. 2.

**[0046]** As described above, although it is preferable that the spiral pitch P is larger for the purpose of preventing the wire diameter of the resistor 4, 5 from increasing, the spiral pitch P is selected to be equal to the coil diameter (2r) of the resistor 4, 5 or less in this embodiment.

**[0047]** Next, a method for producing the glow plug according to the above embodiment will be described. Figs. 4(a) to 4(e) illustrate the steps of the method for the production. First, as shown in Fig. 4(a), a spiral body 100 finally to be a first resistor 4 and a second resistor 5 welded to each other in a fused section 45 is prepared. This spiral body 100 consists of a wire piece 101 (finally to be the first resistor 4) and a wire piece 102 (finally to be the second resistor 5), both made of the same materials as those of the prior art resistors, connected to each other in the fused section 45 by plasma arc welding as described above.

**[0048]** At a step shown in Fig. 4(b), a pair of split jigs 103, 104 are used, which define an interior space corresponding to the circumferential shape of the spiral body 100 when fitted to each other. The split jigs 103, 104 are of a symmetrical shape and arranged opposite to each other while interposing the winding axis M between the both so that the circumference of the spiral body 100 is encircled and held thereby. At that time, the internal shaft 6 has been welded to the spiral body 100.

**[0049]** The pair of split jigs 103, 104 holding the spiral body 100 between them are translated in reverse to each other along the winding axis M while being pressed in the mutual-approaching direction to tilt the spiral body 100 relative to the winding axis M. Thus, the resistor 4, 5 of the shape shown in Figs. 4(c), 3A and 3B is obtained.

**[0050]** As shown in Figs. 5(a) and 5(b), if the spiral body 100 has been prepared in advance to have an oval shape as seen in the direction of the winding axis M (the arrowed direction A in Fig. 5(a)) and is pressed by the pair of split jigs 103, 104 in the direction of the major diameter of the oval (the arrowed direction B in Fig. 5(b)), the oval shape is collapsed to nearly a circular shape as seen in the direction of the winding axis M as shown in Fig. 5(c). The resistor 4, 5 having such a shape is capable of generating heat generally uniformly around the same.

**[0051]** At the step shown in Fig. 4(d), the resistor 4, 5 and part of the internal shaft 6 are inserted into the heater tube 3. Then, a blocked end 3a is formed by fusing a tip end of the heater tube 3 together with the one end 41 of the first resistor 4 by a plasma arc, and the one end 41 of the first resistor 4 is electrically connected to the blocked end 3a. Thereafter, an insulating powder constituting the insulating powdery body 30 is filled in the heater tube 3 and sealed by the seal 33.

**[0052]** Subsequently, at the step shown in Fig. 4(e), the heater tube 3 is swaged in the direction of the winding axis M (the longitudinal direction of the heater tube 3) to increase the filling density of the powdery body 30 in the interior of the tube 3. Thus, the resistor 4, 5 held in the interior of the heater tube 3 is obtained.

**[0053]** Thereafter, a portion of the heater tube 3 closer to the open end 3b is press-fit into the housing 2 through the one end 2a thereof so that the heater tube 3 is fixedly secured to the housing 2. A portion of the internal shaft 6 closer to the other end 62 thereof is fastened the other end 2b of the housing 2 by tightening the nut 9 via the

O-ring 7 and the bush 8. Thus, the glow plug 1 shown in Fig. 1 is obtained.

**[0054]** In this regard, in the above-mentioned glow plug 1, the resistor 4, 5 is tilted in one direction relative to the winding axis M for the purpose of properly restricting the resistance variation caused by a compressive force of the swaging, so that the distance Q at a position of maximized distance Q is 0.75 times the spiral pitch P or more. The basis of such an arrangement will be described below.

**[0055]** Fig. 6 is a graph showing the effect of the present invention, wherein a horizontal axis represents the distance Q at a position of maximized distance Q (a value standardized by the spiral pitch P) and a vertical axis represents the rate of change in resistivity (resistance ( $\Omega$ ) after swaging/resistance ( $\Omega$ ) before swaging). While the swaging rate (rate of change in tube diameter) is 25% in this embodiment, within a range of the swaging rate suitable for glow plugs according to the present invention, substantially the same tendency is observed.

**[0056]** It will be apparent from Fig. 6 that the glow plug 1 according to the embodiment of the present invention wherein the distance Q at a position of maximized distance Q is 0.75 times the spiral pitch P or more is effective for restricting the rate of change in resistivity of the resistor 4, 5 caused by the swaging of the heater tube 3 as compared with the conventional glow plug having the distance Q at a position of maximized distance Q of less than 0.75 times the spiral pitch P. Particularly, if the distance Q at a position of maximized distance Q is equal to the spiral pitch P or more, it is possible to significantly restrict the rate of change in resistivity of the resistor.

**[0057]** As described above, according to the present invention, it is possible to prevent the wire diameter of the resistor 4, 5 from increasing even after the swaging of the heater tube 3, resulting in a glow plug capable of properly restricting the rate of change in resistivity.

**[0058]** Also, according to the present invention, the arrangement is simple in structure in that the resistor 4, 5 is merely tilted in one direction relative to the winding axis M without decreasing the number of spirals, and therefore is suitable for a glow plug necessitating a large resistance in the resistor 4, 5 (for example, to be used with 24V or 42V).

**[0059]** Although the two resistors are connected in series to each other in the above embodiment, the resistor may be one or three or more connected in series or parallel to each other. Also, although both of the resistors 4, 5 are tilted in one direction relative to the winding axis M in the above embodiment, one of them (for example, the first resistor 4) may solely be tilted or part thereof may be tilted so that the resistance in the tilted portion is prevented from decreasing.

**[0060]** Figs. 7A, 7B, 8A and 8B illustrate typical modifications described above.

**[0061]** The dimensional relationship will be described with reference to Figs. 7A, 7B, 8A and 8B. For example, in Fig. 7A, an outer diameter of the heater tube 3 is 5

mm, and there are no larger and smaller diameter portions. A wall thickness of the heater tube 3 is generally in a range from 0.3 mm to 1 mm, the wall thickness of glow plugs which have been produced since the 1960s.

**[0062]** In Figs. 7A, 7B, 8A and 8B, an outer diameter (coil diameter) of the resistor (coil heater) 4, 5 built-in within the heater tube 3 is selected so that a clearance between the resistor and the inner wall of the heater tube 3 (insulating clearance) of 0.1 mm or more is obtained to guarantee the insulation between the resistor 4, 5 and the heater tube 3. Therefore, the outer diameter of the resistor 4, 5 may be even a thinner diameter in a range from 2.5 mm to 4.8 mm as proposed in Japanese Unexamined Patent Publication No. 11-148647.

**[0063]** While the resistor 4 is a coil member made of one kind of material to have the same resistance value in the embodiment shown in Fig. 7A, a combination of several materials to have various resistance values may be adopted for the coil member, provided a tilting portion of two coils or more exists therein as defined in claims. In Fig. 7A, the resistor 4 of the coil member located below the lower end surface of the housing 2 constitutes the above tilting portion.

**[0064]** When two coil members or more are connected together, for example, when the resistor 4 is connected to the resistor 5 as shown in Fig. 1 or 7B, a large gap of one winding exists on the respective side of a position at which the coil members are connected together, for example, in a range from 0.25 mm to 5 mm.

**[0065]** In the resistor 4 shown in Fig. 7A, the diametrical cross-section of the coil wire is of an oval shape after the swaging because the formation of tilting portion. A major diameter of the oval shape is about 1.1 times an auxiliary diameter or more, for example, wherein the auxiliary diameter is in a range from 0.15 mm to 0.8 mm. An outer diameter of the resistor (coil diameter) may have a step difference of 0.05 mm or more provided an insulation clearance of 0.1 mm or more is guaranteed between the heater tube 3 and both the resistors 4, 5.

**[0066]** A projected length of the heater tube 3 from the one end 2a of the housing 2 is, for example, in a range from 10 mm to 60 mm. The one end 61 of the internal shaft 6 may be located at any positions unless it is in contact with the end surface of the open end 3b of the heater tube 3. For instance, the one end 61 may be inserted 4 mm or more into the interior of the heater tube 3 and embedded in the insulating powder.

**[0067]** A diameter of a portion of the internal shaft 6 closer to the one end 61 may be optional provided the insulating clearance of 0.1 mm or more is guaranteed from the inner wall of the heater tube 3; for example, the clearance might be in a range from 1 mm to 5.2 mm. A shape of the internal shaft 6 may be either stepless or multi-stepped as shown in Figs. 7B and 8A. The height difference between the steps is, for example, 0.05 mm or more.

**[0068]** A trend in glow plug heaters is a heater tube 3 having a larger diameter portion 32 and a smaller diam-

eter portion 31 as shown in Figs. 7B and 8A because thinner glow heaters are recently in demand. The larger diameter portion 31 and the smaller diameter portion 32 may be freely combined to each other; one example thereof is that the outer diameter of the smaller diameter portion 31 is in a range from 2.5 mm to 5.5 mm and that of the larger diameter portion 32 is in a range from 3 mm to 6 mm.

**[0069]** Even in such a heater tube 3 having a larger diameter portion 32 and a smaller diameter portion 31, a resistor 4, 5 housed therein may either a single coil member made of the same material having the same resistance value or a combination of coil members made of different materials having different resistance values, provided there is a tilting portion with two windings or more in part of the coil member.

**[0070]** The difference between the embodiments shown in Figs. 7B and 8A resides in that the one end 61 of the internal shaft 6 is positioned outside the housing 2 (Fig. 7B) or inside the same (Fig. 8A). Also, in Fig. 7B, the tilting portions are formed all over the first resistor 4 and part of the second resistor 5 closer to the other end 52 thereof, while remaining part of the second resistor 5 closer to the one end 51 thereof is not the tilting portion.

**[0071]** In the glow plug shown in Fig. 8B, the heater tube 3 is divided into two parts, one of which is housed in the housing 2 and other is projected out of the housing 2. The resistors 4, 5 are held in the respective parts while being embedded in the insulating powder 30. Both the resistors 4, 5 are electrically connected to each other via one part of the internal shaft 6 which is also divided into two parts. In the embodiment shown in Fig. 8B, the resistor 5 in the housing 2 constitutes the tilting portion, and the dimensional relationship between the respective parts is the same as Fig. 7A.

**[0072]** The above-mentioned dimensional relationship is also true of all glow plugs having resistors of a metallic wire (Fe, Cr, Ni, Co, Al, Pt or others) of a spiral shape in the heater tube. The present invention is also applicable to glow plugs which partly formed of ceramic material, provided metallic wires in a spiral shape exist.

**[0073]** While the invention has been described by reference to specific embodiments chosen for the purpose of illustration, it should be apparent that numerous modifications could be made thereto by those skilled in the art without departing from the basic concept and scope of the invention.

## Claims

1. A glow plug comprising a hollow tube (3) and a resistor (4, 5) retained in the tube (3) while being wound in a spiral shape having a winding axis (M) coinciding with a longitudinal axis of the tube (3), the resistor (4, 5) being heated by being energized with a current, wherein a first point (t1) and a second point (t2) are deter-

mined on the resistor (4, 5) so that a spiral pitch (P) of the resistor winding is defined between the both; a third point (t3) is defined at a position opposite to the first point (t1) along the resistor (4, 5) in an imaginary plane (K) including the first point (t1) and the winding axis (M) so that the third point (t3) is spaced from the first point (t1) toward the second point (t2) along the resistor (4, 5);

**characterized in that**

the resistor spiral (4, 5) is so inclined relative to the winding axis (M) that the distance Q between the third point (t3) and the first point (t1) measured in the direction of the winding axis (M) is 0.75 times the spiral pitch (P) or more; and the distance Q being the maximum value relative to the spiral pitch (P) as the resistor (4, 5) turns through 180 degrees on the winding axis (M).

2. A glow plug according to claim 1, **characterized in that** said third point (t3) is defined at a position along the resistor between the first point (t1) and the second point (t2) so that the third point (t3) is at half a length of the resistor wire (4, 5) between the first point (t1) and the second point (t2) along the resistor (4, 5).
3. A glow plug according to claim 1 or 2, **characterized in that** the resistor (4, 5) is inclined relative to the winding axis (M) so that a distance Q between the third point (t3) and the first point (t1) measured in the direction of the winding axis (M) is equal to the spiral pitch (P) or more.
4. A glow plug according to any of claims 1 to 3, **characterized in that** the spiral pitch (P) is selected equal to a coil diameter (2r) of the resistor (4, 5) or less.
5. A method for producing a glow plug according to any one of claims 1 to 4, **characterized in that** the method comprises the steps of:

preparing a spiral body (100) of a wire material wound about a winding axis (M) to finally form the resistor (4, 5);

supporting the circumference of the spiral body (100) with a pair of split jigs (103, 104) arranged opposite to each other relative to the winding axis (M); and

pressing the spiral body (100) by moving the pair of split jigs (103, 104) toward each other while translating the pair of split presser jigs (103, 104) in reverse to each other so that the spiral body (100) is tilted relative to the winding axis (M), after the spiral body (100) is inserted into the tube (3), swaging the tube (3) along the winding axis (M).

## Patentansprüche

1. Glühkerze mit einem Hohlrohr (3) und einem Widerstand (4, 5), der in dem Rohr (3) einbehalten ist, während der Widerstand (4,5) in einer Spiralf orm mit einer Windungsachse (M) gewickelt ist, die mit einer Längsachse des Rohrs (3) zusammenfällt, wobei der Widerstand (4, 5) durch Erregen mit einem Strom erwärmt wird, wobei ein erster Punkt (t1) und ein zweiter Punkt (t2) auf dem Widerstand (4, 5) so bestimmt sind, so dass eine Spiralteilung (P) der Widerstandswicklung zwischen den beiden festgelegt ist; ein dritter Punkt (t3) in einer Position festgelegt ist, die dem ersten Punkt (t1) entlang dem Widerstand (4, 5) in einer imaginären Ebene (K), die den ersten Punkt (t1) und die Windungsachse (M) aufweist, gegenüberliegt, so dass der dritte Punkt (t3) entlang dem Widerstand (4, 5) von dem ersten Punkt (t1) in Richtung des zweiten Punkts (t2) beabstandet ist; **dadurch gekennzeichnet, dass** die Widerstandsspirale (4, 5) relativ zu der Windungsachse (M) derart geneigt ist, dass der Abstand (Q) zwischen dem dritten Punkt (t3) und dem ersten Punkt (t1) in der Richtung der Windungsachse (M) gemessen das 0,75fache der Spiralteilung (P) oder mehr beträgt; und der Abstand (Q) mit Bezug auf die Spiralteilung (P) der Maximalwert ist, wenn sich der Widerstand (4, 5) über 180° um die Windungsachse (M) windet.
2. Glühkerze nach Anspruch 1, **dadurch gekennzeichnet, dass** der dritte Punkt (t3) in einer Position entlang dem Widerstand zwischen dem ersten Punkt (t1) und dem zweiten Punkt (t2) festgelegt ist, so dass sich der dritte Punkt (t3) entlang dem Widerstand (4, 5) auf halber Länge des Widerstanddrahts (4, 5) zwischen dem ersten Punkt (t1) und dem zweiten Punkt (t2) befindet.
3. Glühkerze nach Anspruch 1 oder 2, **dadurch gekennzeichnet, dass** der Widerstand (4, 5) relativ zu der Windungsachse (M) geneigt ist, so dass ein Abstand (Q) zwischen dem dritten Punkt (t3) und dem ersten Punkt (t1) in der Richtung der Windungsachse (M) gemessen gleich der Spiralteilung (P) oder mehr ist.
4. Glühkerze nach einem der Ansprüche 1 bis 3, **dadurch gekennzeichnet, dass** die Spiralteilung (P) gleich einem Spulendurchmesser (2r) des Widerstands (4, 5) oder kleiner gewählt ist.
5. Verfahren zum Herstellen einer Glühkerze gemäß einem der Ansprüche 1 bis 4, **dadurch gekennzeichnet, dass** das Verfahren die folgenden Schritte aufweist:

Vorbereiten eines Spiralkörpers (100) eines Drahtmaterials, das um eine Windungsachse (M) gewunden ist, um schließlich den Widerstand (4, 5) auszubilden;

Halten des Umfangs des Spiralkörpers (100) mit einem Paar von geteilten Vorrichtungen (103, 104), die bezüglich der Windungsachse (M) einander gegenüberliegend angeordnet sind; und Pressen des Spiralkörpers (100) indem das Paar von geteilten Vorrichtungen (103, 104) in einer Richtung aufeinander zu bewegt wird, während das Paar von geteilten Pressvorrichtungen (103, 104) gegenläufig verschoben wird, so dass der Spiralkörper (100) mit Bezug auf die Windungsachse (M) geneigt wird, wobei das Rohr (3) entlang der Windungsachse (M) kaltumgeformt wird, nachdem der Spiralkörper (100) in das Rohr (3) eingebracht wurde.

## Revendications

1. Bougie à incandescence comprenant un tube creux (3) et une résistance (4, 5) retenue dans le tube (3) tout en étant enroulée en forme de spirale ayant un axe d'enroulement (M) coïncidant avec un axe longitudinal du tube (3), la résistance (4, 5) étant chauffée en étant excitée par un courant, dans laquelle un premier point (t1) et un deuxième point (t2) sont déterminés sur la résistance (4, 5) de telle sorte qu'un pas de la spirale (P) de l'enroulement de la résistance soit défini entre eux deux ; un troisième point (t3) est défini au niveau d'une position opposée au premier point (t1) le long de la résistance (4, 5) dans un plan imaginaire (K) incluant le premier point (t1) et l'axe d'enroulement (M) de telle sorte que le troisième point (t3) soit espacé du premier point (t1) vers le deuxième point (t2) le long de la résistance (4, 5) ; **caractérisée en ce que** la spirale de la résistance (4, 5) est tellement inclinée par rapport à l'axe de l'enroulement (M) que la distance Q entre le troisième point (t3) et le premier point (t1) mesurée dans la direction de l'axe de l'enroulement (M) soit 0,75 fois le pas de la spirale (P) ou plus ; et la distance Q étant la valeur maximum par rapport au pas de la spirale (P) lorsque la résistance (4, 5) tourne de 180 degrés sur l'axe de l'enroulement (M).
2. Bougie à incandescence selon la revendication 1, **caractérisée en ce que** ledit troisième point (t3) est défini à une position le long de la résistance entre le premier point (t1) et le deuxième point (t2) de telle sorte que le troisième point (t3) est à la moitié d'une longueur du fil de la résistance (4, 5) entre le premier point (t1) et le deuxième point (t2) le long de la résistance (4, 5).

3. Bougie à incandescence selon la revendication 1 ou 2, **caractérisée en ce que** la résistance (4, 5) est inclinée par rapport à l'axe de l'enroulement (M) de telle sorte qu'une distance Q entre le troisième point (t3) et le premier point (t1) mesurée dans la direction de l'axe de l'enroulement (M) soit égale au pas de la spirale (P) ou plus. 5
4. Bougie à incandescence selon l'une quelconque des revendications 1 à 3, **caractérisée en ce que** le pas de la spirale (P) est sélectionné égal à un diamètre de bobine (2r) de la résistance (4, 5) ou moins. 10
5. Procédé pour produire une bougie à incandescence selon l'une quelconque des revendications 1 à 4, **caractérisé en ce que** le procédé comprend les étapes consistant à : 15
- préparer un corps de spirale (100) d'un matériau de fil enroulé autour d'un axe de l'enroulement (M) pour former finalement la résistance (4, 5) ; 20
- supporter la circonférence du corps de la spirale (100) avec une paire de gabarits séparés (103, 104) placés l'un en face de l'autre par rapport à l'axe de l'enroulement (M) ; et 25
- presser le corps de la spirale (100) en déplaçant la paire de gabarits séparés (103, 104) l'un vers l'autre tout en faisant subir une translation à la paire de gabarits presseurs séparés (103, 104) en sens inverse l'un par rapport à l'autre de telle sorte que le corps de la spirale (100) soit incliné par rapport à l'axe de l'enroulement (M), après que le corps de la spirale (100) est inséré dans le tube (3), en sertissant le tube (3) le long de l'axe de l'enroulement (M). 30 35

40

45

50

55



Fig.2

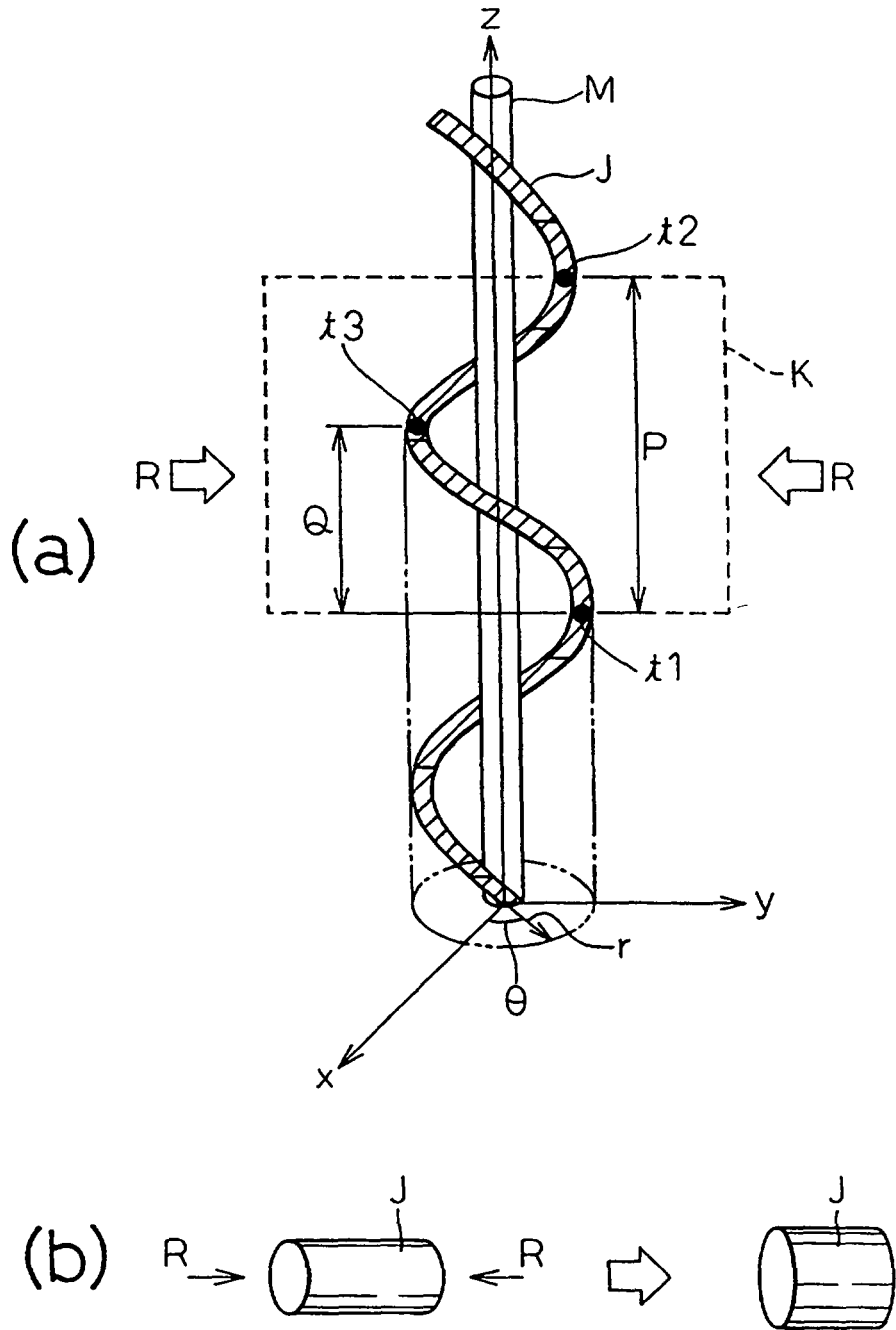

Fig.3B

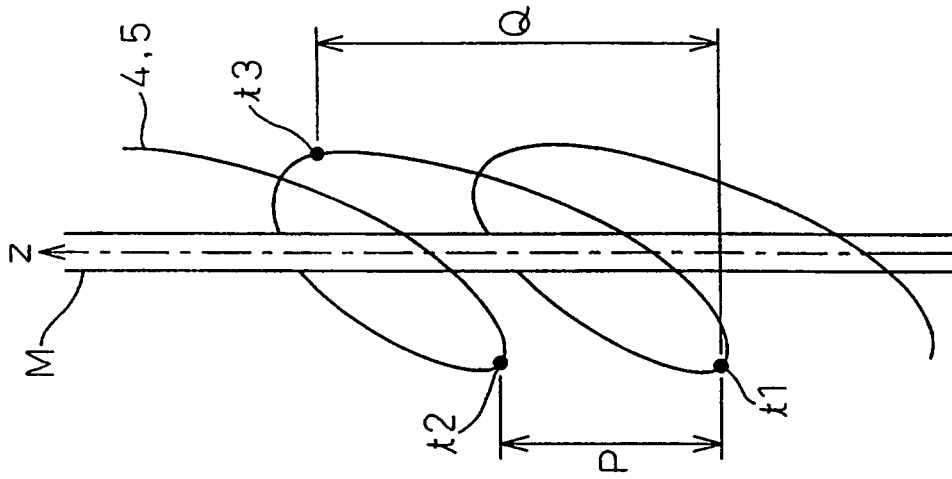

Fig.3A

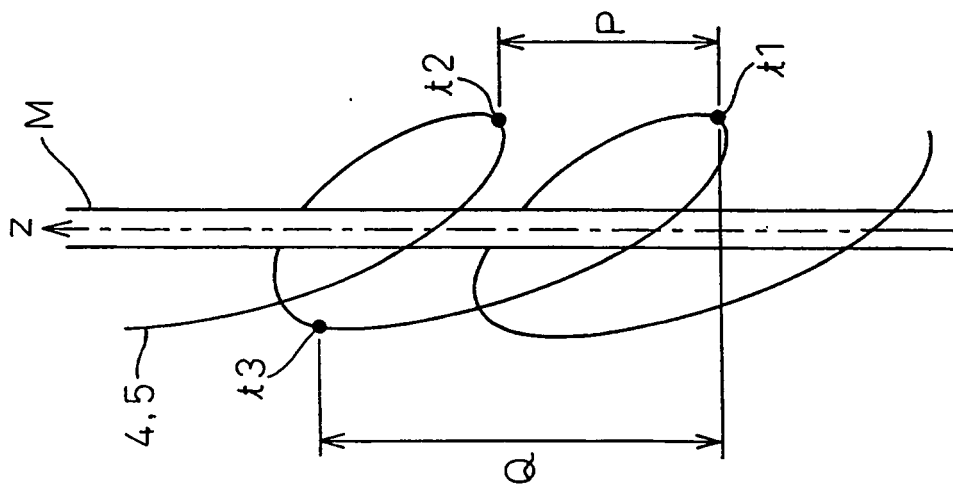

Fig.4

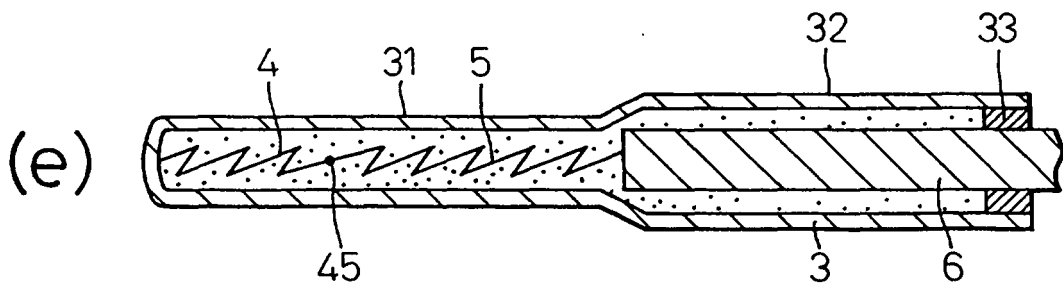
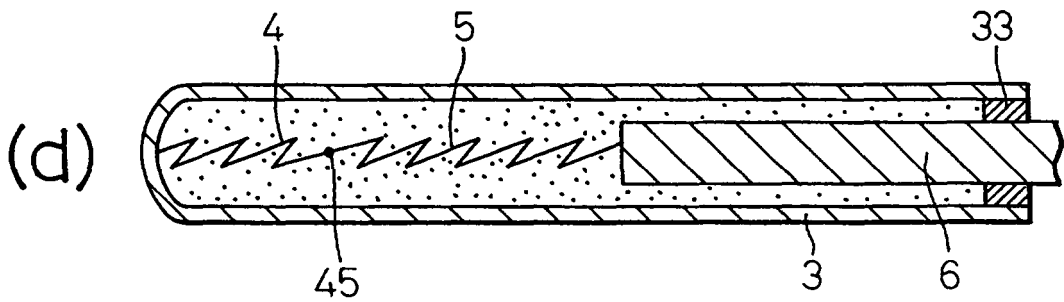
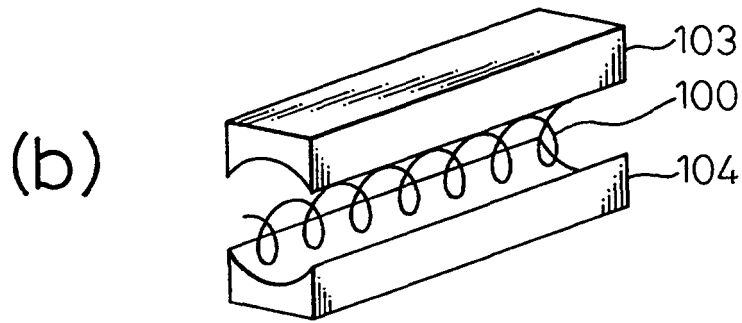
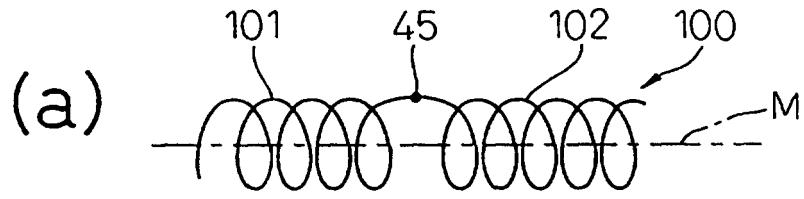

Fig.5

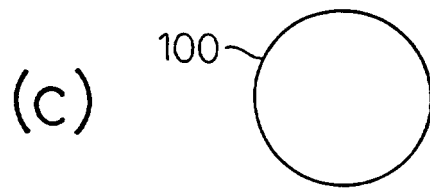
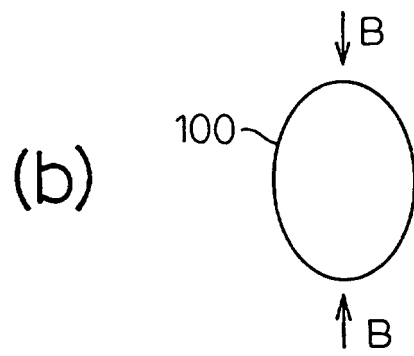
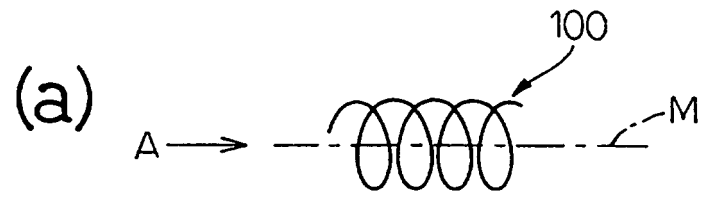

Fig.6

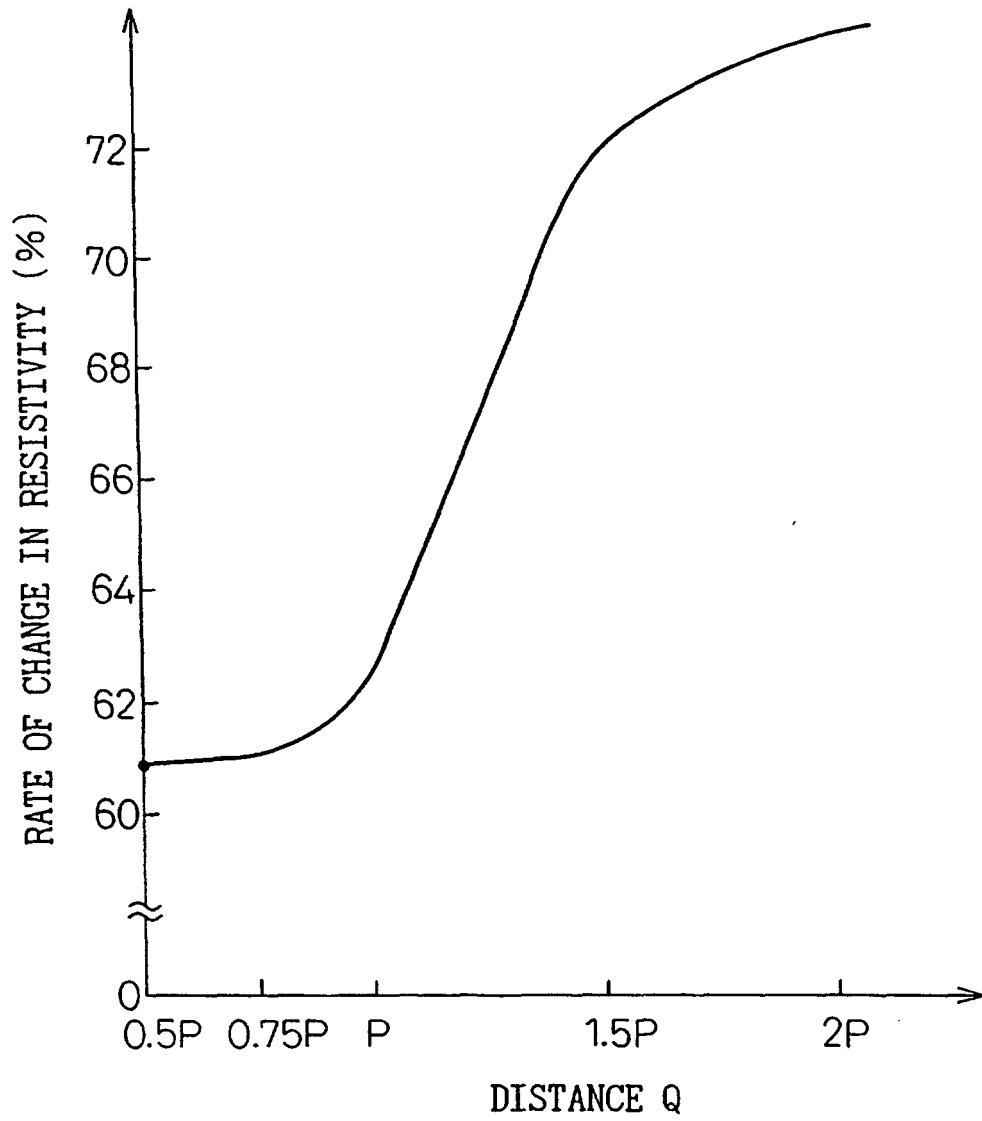

Fig.7A

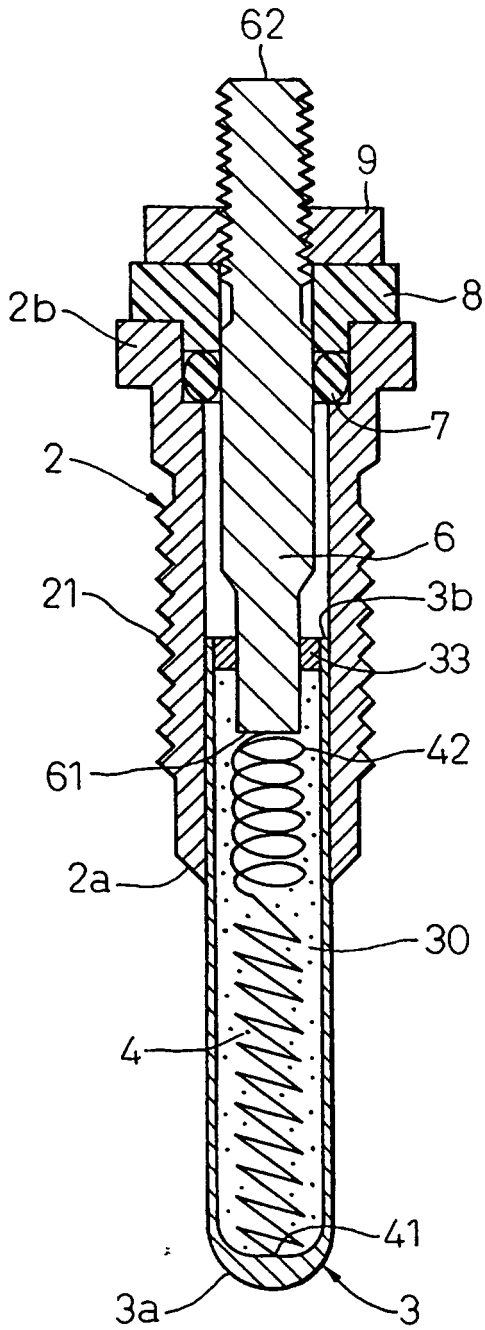

Fig.7B

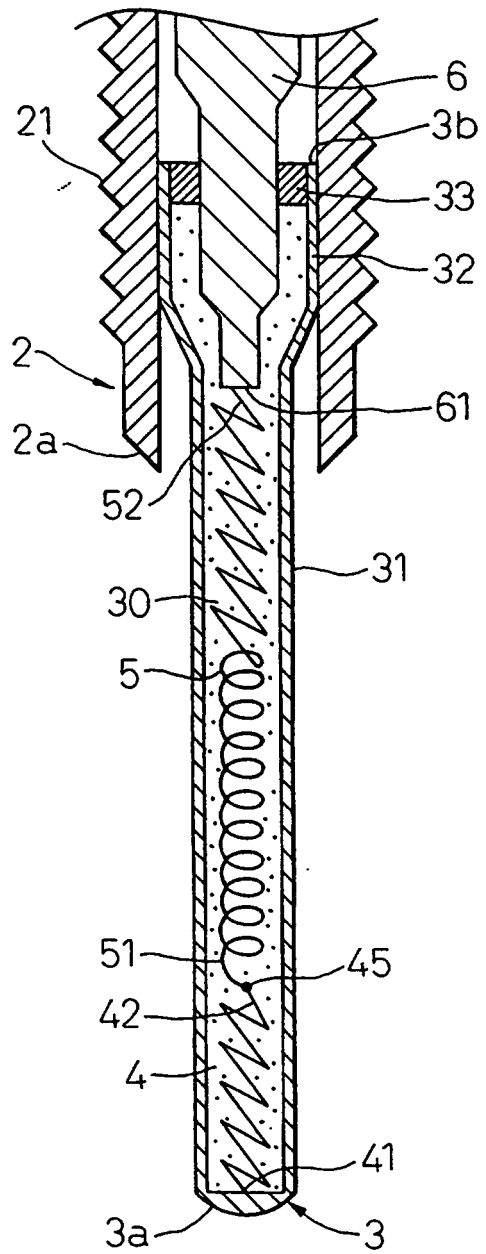

Fig.8A

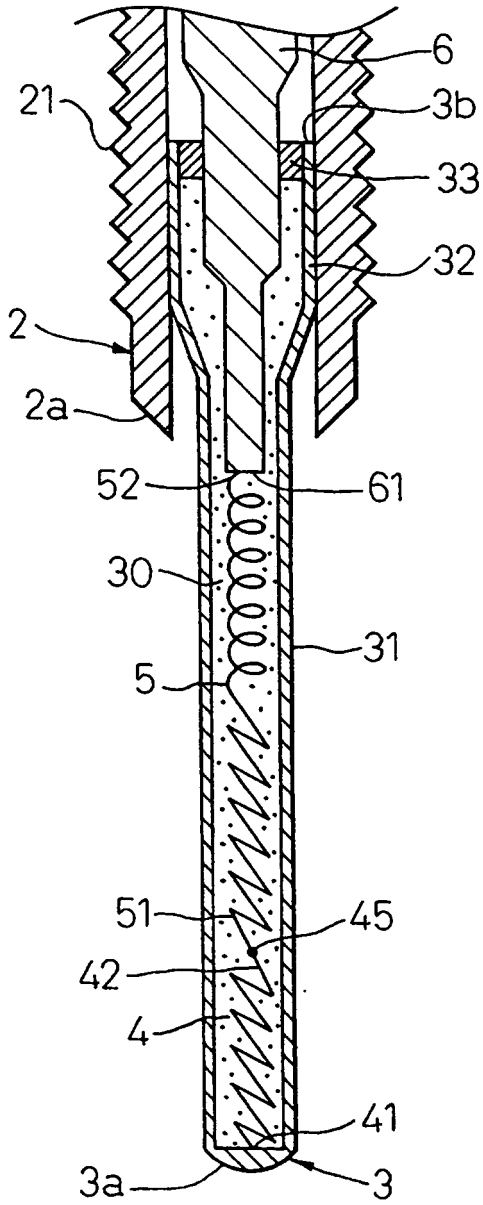
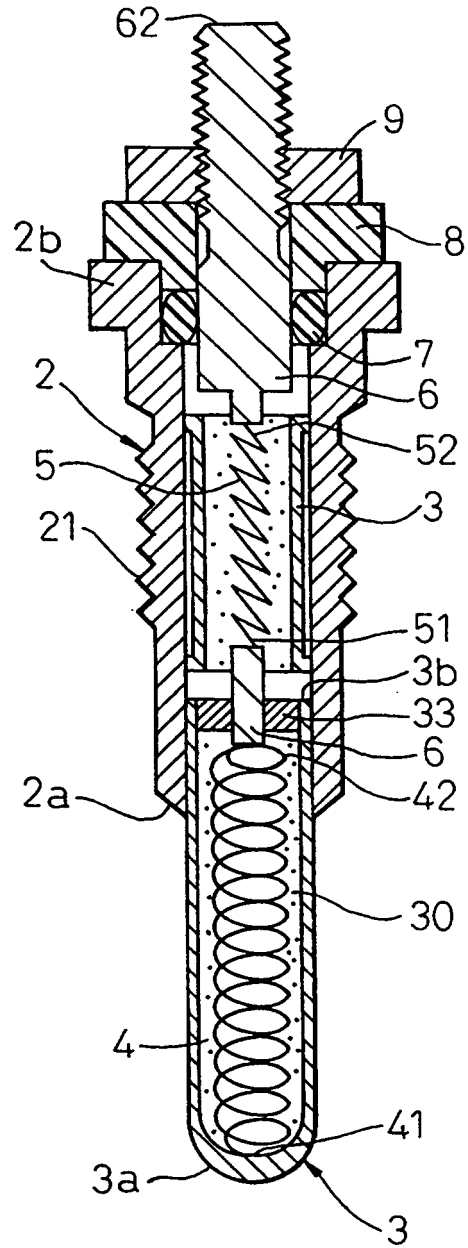

Fig.8B



**REFERENCES CITED IN THE DESCRIPTION**

*This list of references cited by the applicant is for the reader's convenience only. It does not form part of the European patent document. Even though great care has been taken in compiling the references, errors or omissions cannot be excluded and the EPO disclaims all liability in this regard.*

**Patent documents cited in the description**

- EP 0602745 A [0002]
- JP 9217933 A [0003]
- JP 11148647 A [0062]