



FR, GB, GR, HR, HU, IE, IS, IT, LT, LU, LV, MC, MT, NL,
NO, PL, PT, RO, SE, SI, SK, TR), OAPI (BF, BJ, CF, CG,
CI, CM, GA, GN, GQ, GW, ML, MR, NE, SN, TD, TG).

— *before the expiration of the time limit for amending the
claims and to be republished in the event of receipt of
amendments*

Published:

— *with international search report*

METHODS AND APPARATUS FOR DISPENSING SOLID PHARMACEUTICAL ARTICLES

Related Application(s)

[001] The present application claims the benefit of U.S. Provisional Patent Application No. 60/938,835, filed May 18, 2007, the disclosure of which is hereby incorporated herein by reference in its entirety.

Field of the Invention

[002] The present invention is directed generally to the dispensing of solid pharmaceutical articles and, more specifically, is directed to the automated dispensing of solid pharmaceutical articles.

Background of the Invention

[003] Pharmacy generally began with the compounding of medicines which entailed the actual mixing and preparing of medications. Heretofore, pharmacy has been, to a great extent, a profession of dispensing, that is, the pouring, counting, and labeling of a prescription, and subsequently transferring the dispensed medication to the patient. Because of the repetitiveness of many of the pharmacist's tasks, automation of these tasks has been desirable.

[004] Some attempts have been made to automate the pharmacy environment. For example, U.S. Patent No. 6,971,541 to Williams et al. describes an automated system for dispensing pharmaceuticals using dispensing bins. Each dispensing bin includes a hopper in which tablets are stored and a dispensing channel fluidly connecting the hopper to a dispensing outlet. Forward and reverse air flows are used to selectively convey the tablets through the dispensing channel in each of a dispensing direction (toward the outlet) and a reverse direction (toward the hopper). A counting sensor is positioned proximate the outlet of the dispensing channel and used to detect tablets passing the sensor in order to maintain a count of the tablets dispensed.

Summary of the Invention

[005] According to some embodiments of the present invention, a method is provided for dispensing solid pharmaceutical articles using an apparatus including a housing and a sensor system, the housing defining a dispensing passage having a dispensing inlet and a dispensing outlet downstream of the dispensing inlet, the sensor system including first and second sensors spaced apart along the dispensing channel such that the second sensor is located downstream of the first sensor. The method includes: forcing at least one article along a path through the dispensing passage; generating detection signals using the first and second sensors responsive to articles passing through the dispensing channel; and using the detection signals from the first and second sensors to monitor dispensing performance of the apparatus.

[006] According to some embodiments of the present invention, an apparatus for dispensing solid pharmaceutical articles includes a housing, a drive mechanism and a sensor system. The housing defines a dispensing passage having a dispensing inlet and a dispensing outlet downstream of the dispensing inlet. The drive mechanism serves to force the articles along a path through the dispensing passage between the dispensing inlet and the dispensing outlet. The sensor system includes first and second sensors operative to detect articles passing through the dispensing passage and a controller to receive and use detection signals from the first and second sensors to monitor dispensing performance of the apparatus. The first and second sensors are spaced apart along the dispensing channel such that the second sensor is located downstream of the first sensor.

[007] According to some embodiments of the present invention, a method is provided for dispensing solid pharmaceutical articles using an apparatus including a housing and a sensor system, the housing defining a dispensing channel having a dispensing inlet and a dispensing outlet downstream of the dispensing inlet, the sensor system including first and second sensors positioned along the dispensing channel. The method includes: forcing at least one article along a path through the dispensing channel; generating detection signals using the first and second sensors responsive to articles passing through the dispensing channel; and comparing the detection signals from the first and second sensors to determine whether a dispensing fault condition has occurred.

[008] According to some embodiments of the present invention, a method is provided for dispensing solid pharmaceutical articles using an apparatus including a housing and a sensor system, the housing defining a dispensing channel having a dispensing inlet and a dispensing outlet downstream of the dispensing inlet, the sensor system including at least one sensor positioned along the dispensing channel. The method includes: forcing at least one article along a path through the dispensing channel; generating detection signals using the at least one sensor responsive to articles passing through the dispensing channel; and using a duration of at least one of the detection signals from the at least one sensor to determine whether a dispensing fault condition has occurred.

[009] Further features, advantages and details of the present invention will be appreciated by those of ordinary skill in the art from a reading of the figures and the detailed description of the preferred embodiments that follow, such description being merely illustrative of the present invention.

Brief Description of the Drawings

[010] **Figure 1** is a flow chart illustrating methods according to embodiments of the present invention.

[011] **Figure 2** is a perspective view of a pharmaceutical tablet dispensing system including a sensor system according to embodiments of the present invention.

[012] **Figure 3** is a cutaway view of the tablet dispensing system of **Figure 2** illustrating a container dispensing station, a labeling carrier, a dispensing carrier, and a closure dispensing station thereof.

[013] **Figure 4** is a front perspective view of a dispensing bin according to embodiments of the present invention.

[014] **Figure 5** is a cross-sectional view of the bin of **Figure 4** filled with tablets at rest.

[015] **Figure 6** is a cross-sectional view of the bin of **Figure 4** wherein tablets contained therein are being agitated and dispensed in a forward or dispensing direction.

[016] **Figure 7** is a cross-sectional view of the bin of **Figure 4** wherein a tablet is being returned to a hopper of the bin in a reverse direction.

[017] **Figure 8** is a block diagram representing a sensor system and control valves of the pharmaceutical dispensing system of **Figure 1**.

[018] **Figures 9-13** are schematic diagrams representing detection pulse signals of an entrance sensor and an exit sensor of the sensor system of **Figure 8** over time.

Detailed Description of Embodiments of the Invention

[019] The present invention now will be described more fully hereinafter with reference to the accompanying drawings, in which illustrative embodiments of the invention are shown. In the drawings, the relative sizes of regions or features may be exaggerated for clarity. This invention may, however, be embodied in many different forms and should not be construed as limited to the embodiments set forth herein; rather, these embodiments are provided so that this disclosure will be thorough and complete, and will fully convey the scope of the invention to those skilled in the art.

[020] It will be understood that when an element is referred to as being "coupled" or "connected" to another element, it can be directly coupled or connected to the other element or intervening elements may also be present. In contrast, when an element is referred to as being "directly coupled" or "directly connected" to another element, there are no intervening elements present. Like numbers refer to like elements throughout.

[021] In addition, spatially relative terms, such as "under", "below", "lower", "over", "upper" and the like, may be used herein for ease of description to describe one element or feature's relationship to another element(s) or feature(s) as illustrated in the figures. It will be understood that the spatially relative terms are intended to encompass different orientations of the device in use or operation in addition to the orientation depicted in the figures. For example, if the device in the figures is turned over, elements described as "under" or "beneath" other elements or features would then be oriented "over" the other elements or features. Thus, the exemplary term "under" can encompass both an orientation of over and under. The device may be otherwise oriented (rotated 90 degrees or at other orientations) and the spatially relative descriptors used herein interpreted accordingly.

[022] The terminology used herein is for the purpose of describing particular embodiments only and is not intended to be limiting of the invention. As used herein, the singular forms "a", "an" and "the" are intended to include the plural forms as well, unless the context clearly indicates otherwise. It will be further understood that the

terms "comprises" and/or "comprising," when used in this specification, specify the presence of stated features, integers, steps, operations, elements, and/or components, but do not preclude the presence or addition of one or more other features, integers, steps, operations, elements, components, and/or groups thereof. As used herein the expression "and/or" includes any and all combinations of one or more of the associated listed items.

[023] Unless otherwise defined, all terms (including technical and scientific terms) used herein have the same meaning as commonly understood by one of ordinary skill in the art to which this invention belongs. It will be further understood that terms, such as those defined in commonly used dictionaries, should be interpreted as having a meaning that is consistent with their meaning in the context of the relevant art and will not be interpreted in an idealized or overly formal sense unless expressly so defined herein.

[024] In accordance with embodiments of the present invention apparatus and methods are provided for dispensing solid pharmaceutical articles. In particular, such methods and apparatus may be used to dispense pharmaceuticals. With reference to **Figure 1**, methods according to embodiments of the present invention may be executed using an apparatus including a housing, a flow generator, and a sensor system, the housing defining a dispensing channel having a dispensing inlet and a dispensing outlet downstream of the dispensing inlet, the sensor system including first and second sensors spaced apart along the dispensing channel such that the second sensor is located downstream of the first sensor. At least one drive gas flow is generated using the flow generator to force at least one article along a path through the dispensing channel (**Block 20**). The dispensing channel may or may not be fully enclosed. Responsive to articles passing through the dispensing channel, detection signals are generated using the first and second sensors (**Block 22**). The detection signals from the first and second sensors are used to monitor dispensing performance of the apparatus (**Block 24**). According to some embodiments, the articles are pharmaceutical tablets.

[025] A dispensing system according to embodiments of the present invention and that can carry out the foregoing methods is illustrated in **Figures 2-8** and designated broadly therein at **40** (**Figures 2 and 3**). The dispensing system **40** includes a sensor system **102** (**Figure 8**) according to embodiments of the present invention. The system **40** includes a support frame **44** for the mounting of its various components. Those skilled in

this art will recognize that the frame 44 illustrated herein is exemplary and can take many configurations that would be suitable for use with the present invention. The frame 44 provides a strong, rigid foundation to which other components can be attached at desired locations, and other frame forms able to serve this purpose may also be acceptable for use with this invention.

[026] The system 40 generally includes as operative stations a controller (represented herein by a graphical user interface 42), a container dispensing station 58, a labeling station 60, a tablet dispensing station 62, a closure dispensing station 64, and an offloading station 66. In the illustrated embodiment, containers, tablets and closures are moved between these stations with a dispensing carrier 70; however, in some embodiments, multiple carriers are employed. The dispensing carrier 70 has the capability of moving the container to designated locations within the cavity 45 of the frame 44. Except as discussed herein with regard to the dispensing station 62, each of the operative stations and the conveying devices may be of any suitable construction such as those described in detail in U.S. Patent No. 6,971,541 to Williams et al. and/or U.S. Patent Publication No. US-2006-0241807-A1, the disclosures of which are hereby incorporated herein in their entireties.

[027] The controller 42 controls the operation of the remainder of the system 40. In some embodiments, the controller 42 will be operatively connected with an external device, such as a personal or mainframe computer, that provides input information regarding prescriptions. In other embodiments, the controller 42 may be a stand-alone computer that directly receives manual input from a pharmacist or other operator. An exemplary controller is a conventional microprocessor-based personal computer.

[028] In operation, the controller 42 signals the container dispensing station 58 that a container of a specified size is desired. In response, the container dispensing station 58 delivers a container for retrieval by the carrier 70. From the container dispensing station 58, the container is moved to the labeling station 60 by the carrier 70. The labeling station 60 includes a printer that is controlled by the controller 42. The printer prints and presents an adhesive label that is affixed to the container.

[029] Filling of labeled containers with tablets is carried out by the tablet dispensing station 62. The tablet dispensing station 62 comprises a plurality of tablet dispensing bin assemblies or bins 100 (described in more detail below), each of which

holds a bulk supply of individual tablets (typically the bins **100** will hold different tablets). Referring to **Figures 4 and 5**, the dispensing bins **100**, which may be substantially identical in size and configuration, are organized in an array mounted on the rails of the frame **44**. Each dispensing bin **100** has a dispensing passage or channel **120** with an outlet **124** that faces generally in the same direction, to create an access region for the dispensing carrier **70**. The identity of the tablets in each bin is known by the controller **42**, which can direct the dispensing carrier **70** to transport the container to the proper bin **100** to fill the particular prescription. In some embodiments, the bins **100** may be labeled with a bar code or other indicia to allow the dispensing carrier **70** to confirm that it has arrived at the proper bin **100**.

[030] The dispensing bins **100** are configured to singulate, count, and dispense the tablets contained therein, with the operation of the bins **100** and the counting of the tablets being controlled by the controller **42**. Some embodiments may employ the controller **42** as the device which monitors the locations and contents of the bins **100**; others may employ the controller **42** to monitor the locations of the bins, with the bins **100** including indicia (such as a bar code or electronic transmitter) to identify the contents to the controller **42**. In still other embodiments, the bins **100** may generate and provide location and content information to the controller **42**, with the result that the bins **100** may be moved to different positions on the frame **42** without the need for manual modification of the controller **42** (*i.e.*, the bins **100** will update the controller **42** automatically).

[031] Any of a number of dispensing units that singulate and count discrete objects may be employed if suitably modified to include the inventive aspects disclosed herein. In particular, dispensing units that rely upon targeted air flow and a singulating nozzle assembly may be used, such as the devices described in U.S. Patent No. 6,631,826 to Pollard et al. and/or U.S. Patent Publication No. US-2006-0241807-A1, each of which is hereby incorporated herein by reference in its entirety. Bins of this variety may also include additional features, such as those described below.

[032] After the container is desirably filled by the tablet dispensing station **62**, the dispensing carrier **70** moves the filled container to the closure dispensing station **64**. The closure dispensing station **64** may house a bulk supply of closures and dispense and secure them onto a filled container. The dispensing carrier **70** then moves to the

closed container, grasps it, and moves it to the offloading station 66.

[033] Turning to the bins 100 in more detail, an exemplary bin 100 is shown in more detail in **Figures 4-8**. The bin 100 includes a housing 110 having a hopper portion 112 and a nozzle 114.

[034] Referring to **Figure 6**, the hopper portion 112 defines a hopper chamber 112A that can be filled with tablets T. A lower screen 130A is provided in the floor of the hopper portion 112 and an upper screen 130B is provided in the ceiling of the hopper portion 112. As discussed below, air or other suitable gas can be flowed through the screens 130A, 130B and the chamber 112A to agitate the tablets T contained therein.

[035] With reference to **Figure 5**, the nozzle 114 defines a dispensing channel 120 through which the tablets T can be dispensed one at a time. The dispensing channel 120 has an inlet 122 adjacent and fluidly connecting the channel 120 to the chamber 112A. The dispensing channel 120 has an outlet 124 downstream from and opposite the inlet 122 and through which tablets may exit the nozzle 114 to be dispensed into the container C (**Figure 7**).

[036] The housing 110 further includes a low pressure port 132 and a high pressure nozzle 134 (**Figures 4 and 6**). A door 132A is provided to selectively open and close the port 132 by operation of an associated solenoid 132B.

[037] With continued reference to **Figure 5**, a forward jet passage 140 is fluidly connected to the high pressure nozzle 134 and terminates in a forward jet aperture 140A at the dispensing channel 120. A forward control valve 142 is operable to control airflow to the jet aperture 140A. A rearward or reverse jet passage 144 is also fluidly connected to the high pressure nozzle 134 and terminates in a rearward or reverse jet aperture 144A at the dispensing channel 120. A reverse control valve 146 is operable to control airflow to the jet aperture 144A.

[038] According to some embodiments and as described in U.S. Patent Publication No. US-2006-0241807-A1, the tablet dispensing station 62 includes a low pressure manifold 74 fluidly connected to a low pressure source such as a vacuum motor (not shown), which provides low level (*i.e.*, about 2 psi) suction to draw air through (in succession) the screen 130A, the chamber 112A, the screen 130B and the port 132 to agitate tablets within the hopper chamber 112A (**Figure 6**). Also, a high

pressure (*i.e.*, about 30 psi) conduit 72 fluidly connected to a high pressure source (not shown) is fluidly connected to the high pressure nozzle 134 to supply high pressure air to the jet apertures 140A, 144A. Further, a connector circuit board 77 is mounted horizontally below the manifold 74. The circuit board 77 or other electrical connector provides an electrical connection between the controller 42 and a bin-controlling circuit board 78 (or other electronic component) of the bin 100 for power and data signals to/from the controller 42.

[039] The sensor system 102 includes a front or exit sensor 80 and a rear or entrance sensor 84 positioned along the channel 120. The exit sensor 80 is located downstream (*i.e.*, in the forward or dispensing direction of the tablet flow path through the dispensing channel 120) from the entrance sensor 84 along the dispensing channel 120. The exit sensor 80 is mounted in the nozzle 114 proximate the outlet 124 and distal from the inlet 122 and faces the channel 120. The entrance sensor 84 is mounted in the nozzle 114 proximate the inlet 122 and distal from the outlet 124 and also faces the channel 120. The sensors 80, 84 are tablet detecting sensors and are operably connected to associated sensor receiver/processor electronics. The sensors 80, 84 may be electrically connected to an associated controller by lead wires 80A, 84A. According to some embodiments, the associated controller is or includes the controller 42 and/or the circuit board 78. As further discussed below, the sensors 80, 84 are configured and positioned to detect the tablets T as they pass through the dispensing channel 120. The sensors 80, 84 and the associated controller 42 together comprise a sensor system 102 operative to monitor flow of tablets T through the channel 120 and, thereby, dispensing performance of the bin 100. According to some embodiments, the controller 42 uses detection signals from at least one of the sensors 80, 84 to count the dispensed tablets. According to some embodiments, at least the exit sensor 80 is used for this purpose. In some cases, the sensor system operates the valves 142, 146 or other devices in response to identified or determined conditions or performance in dispensing. While two sensors 80, 84 are described herein, apparatus and methods according to embodiments of the present invention may use sensor systems that use more than two tablet detection sensors along the flow path.

[040] According to some embodiments, the sensors 80, 84 are photoelectric sensors. According to some embodiments, the sensors 80, 84 are infrared (IR) sensors.

According to some embodiments, photoemitters **82** and **86** (e.g., IR emitters) are mounted in the nozzle opposite the sensors **80** and **84**, respectively, to emit photoemissions toward the respective sensors **80**, **84** across the channel **120**. The photoemitters **82**, **86** may be operatively connected to the controller **42** or circuit board **78** by wires **82A**, **86A**. According to some embodiments, all or some of the components **80**, **84** and **82**, **86** may include both a photoemitter and a photodetector, whereby the components **82**, **86** may also serve as sensors. For the purpose of explanation, the illustrated embodiment will be described with only the components **80**, **84** being sensors (*i.e.*, the sensors **80**, **84** receive photoemissions from the photoemitters **82**, **86**). Other types of sensors may be employed as well. Other suitable types of sensors may include, for example, UV, RF, capacitive and EMF sensors.

[041] The exit sensor **80** and the entrance sensor **84** are spaced apart along the channel **120** a distance **D** (**Figure 5**). The preferred or minimum distance **D** may be determined by the type of sensor and/or other parameters or arrangements or physical limitations of the components. According to some embodiments, the distance **D** should be large enough to prevent cross-talk between the components and to provide two distinct signals from the respective sensors **80**, **84**. The minimum distance **D** may also be limited or determined by the time needed to prevent an extra pill from exiting the channel **120** (*i.e.*, once the requested count is reached, the distance **D** should allow enough time to stop an extra pill from exiting).

[042] According to some embodiments, the entrance sensor **84** is positioned along the channel **120** at, in or immediately adjacent the inlet **122**. According to some embodiments, the exit sensor **80** is positioned along the channel **120** at, in or immediately adjacent the outlet **124**.

[043] Exemplary operation of the dispensing system **40** will now be described. The bin **100** is filled with tablets **T** to be dispensed. The tablets **T** may initially be at rest as shown in **Figure 5**. At this time, the valves **142**, **146** are closed so that no gas flow is provided through the jet outlets **140A**, **144A**.

[044] To fill the container **C**, the dispensing carrier **70**, directed by the controller **42**, moves the container **C** to the exit port of the selected dispensing bin **100**. The controller **42** signals the solenoid **132B** to open the door **132A**. This opening of the door **132A** draws low pressure air up through the hopper chamber **112A** to the

manifold 74, thereby agitating the tablets T contained in the hopper chamber 112B.

[045] Once agitation has commenced, the controller 42 signals the forward valve 142 to open (while the reverse valve 146 remains closed). The opened valve 142 permits the pressurized gas from the gas source 72 to flow through the passage 140 and out through the forward drive jet outlet 140A. The pressurized flow from the jet outlet 140A creates a high velocity gas jet that generates suction that causes a forward flow FF of high pressure, high velocity air to be drawn outwardly through the dispensing channel 120 in a dispensing direction (Figure 6). Tablets T are oriented into a preferred orientation by the shape of the inlet 122 to the dispensing channel 120 and dispensed into the container C through the dispensing channel 120 and the outlet 124 under the force of the forward flow FF.

[046] Once dispensing is complete (*i.e.*, a predetermined number of tablets have been counted by the controller 42 as dispensed), the controller 42 activates the forward valve 142 to close and the reverse valve 146 to open. The opened valve 146 permits the pressurized gas from the gas source 72 to flow through the passage 144 and out through the reverse drive jet outlet 144A. The pressurized flow from the jet outlet 144A creates a high velocity gas jet that generates suction that causes a reverse (*i.e.*, rearward) flow FR of high pressure air to be drawn inwardly through the dispensing channel 120 toward the chamber 112A in a reverse or return direction. In this manner, the airflow is reversed and any tablets T remaining in the channel 120 are returned to the chamber 112A under the force of the reverse flow (Figure 7).

[047] While, in the foregoing description, the controller 42 controls the valves 142, 146, the valves 142, 146 may alternatively be controlled by a local controller unique to each bin 100. The bin 100 can be filled or replenished with tablets via access from a pivoting door 127 (Figure 5) located at the upper rear portion of the bin 100, for example. As disclosed in U.S. Patent Publication No. US-2006-0241807-A1, the bin 100 may include components that permit the entry to the dispensing channel 120 to be adjusted in size to complement the size and configuration of the tablet to be dispensed.

[048] During the dispensing phase (*i.e.*, when the forward flow FF is being generated), a tablet jam may occur. A tablet jam is a condition wherein one or more tablets are caught up in the bin 100 such that tablets T will not feed into or through the dispensing channel 120 under the force of the forward flow FF. A jam is indicated if

the entrance sensor **84** has not detected a pill within a specified time period (*e.g.*, one second). When a tablet jam is identified by the controller **42**, the controller **42** will close the forward valve **142** and open the reverse valve **146** to generate the reverse flow **FR** to clear a perceived tablet jam. This action of the controller **42** may be referred to as issuing a "jam clear".

[049] According to some embodiments, the controller **42** will execute a calibration procedure between dispensing sessions (*i.e.*, between the end of a forward flow **FF** and the initiation of the next forward flow **FF**) in order to calibrate the sensors **80**, **84**. According to some embodiments, the calibration procedure includes opening the reverse valve **146** to generate the reverse flow **FR** while calibrating the sensors **80**, **84**. This may ensure that no tablets or tablet fragments occlude the sensors **80**, **84** and thereby corrupt the calibration. The controller **42** may conduct the calibration procedure automatically and/or shortly or immediately after a dispensing session and the bin **100** may remain idle (*i.e.*, with neither a forward flow **FF** nor a reverse flow **FR** being generated) during an idle period between the end of the calibration reverse flow **FR** and the initiation of the next dispensing session.

[050] Typically, an operator will request that a desired number of tablets be dispensed ("the requested count"). The sensors **80**, **84** detect the tablets **T** as they pass through predetermined points in the dispensing channel **120**, as discussed in more detail below. The controller **42** uses the detection signals from the sensors **80**, **84** to monitor and maintain a registered count of the tablets **T** dispensed ("the system count"). When the system count matches the requested count, the controller **42** will deem the dispensing complete and cease dispensing of the tablets **T**. If the controller miscounts the tablets actually dispensed, there may be a mismatch between the requested count and the final actual count.

[051] In practice and in the absence of the apparatus and methods of the present invention, the foregoing processes may suffer from various fault conditions or other dispensing concerns. In prior art systems of the type employing only a single counting sensor or set of counting sensors at one location along the dispensing channel (*e.g.*, at the exit end) to detect tablets in the dispensing channel (hereinafter referred to as "prior art single sensor systems"), these fault conditions may result in inaccurate counts such as counting a tablet that is not dispensed, failing to count a tablet that is

dispensed, or failing to recognize a partial tablet.

[052] The foregoing concerns may be addressed by the sensor system 102 of the bin 100 and methods in accordance with embodiments of the present invention. According to some embodiments, the entrance sensor 84 proximate the inlet 122 of the channel 120 performs the duty of detecting tablet jams and the exit sensor 80 proximate the exit or outlet 124 performs the duty of counting the dispensed tablets. By separating these two functions, the exit sensor 80 (*i.e.*, the count sensor) can be guarded by the entrance sensor 84 (*i.e.*, the jam sensor) to ensure that no tablets are in the dispensing channel 120 during a jam clear. The two sensors 80, 84 can also be cooperatively employed to detect and identify other modes of failure.

[053] Such failure modes are called "exception events" and arise when the sensor output does not follow the expected pulse width and travel times for a singulated pill in standard operation of the bin 100. Some exception events and corresponding operations of the bin 100 that may be encountered will be described hereinbelow. However, it will be appreciated that this description is not exhaustive of the advantageous uses of the apparatus in accordance with embodiments of the present invention.

[054] In some cases, two or more tablets T may be disposed or "preloaded" in the channel 120 in or closely adjacent the inlet 122 prior to actuation of the forward valve 142 to generate the forward flow FF. This condition may be referred to as a "preload dispensing fault condition". A preload dispensing fault condition may occur when tablets in the dispensing channel 120 are not fully returned to the hopper chamber 112A by a reverse flow or "jam clear" intended to clear the dispensing channel 120, for example. A preload dispensing fault condition may also occur when tablets unintentionally migrate into the dispensing channel 120 from the hopper. For example, during the idle period between a jam clear or other reverse flow FR and the initiation of the next forward flow FF, tablets may slide or vibrate out of the hopper chamber 112A and into the inlet 122 or the dispensing channel 120. In prior art single sensor systems, upon initiation of the forward flow FF, the two or more preloaded tablets may travel down the channel 120 in contact with or very closely adjacent one another so that the two or more tablets pass the counting sensor (which is typically located proximate the dispensing outlet) together. The counting sensor may generate only a single, extra long

detection pulse for the two or more tablets rather than two or more discrete pulses that are required to register a count of two or more tablets. As a result, two or more tablets are dispensed through the dispensing outlet but the system count of dispensed tablets is only incremented by one tablet.

[055] In accordance with embodiments of the present invention, a preload dispensing fault condition can be identified and corrected by monitoring the entrance sensor **84**. More particularly, the entrance sensor **84** is configured and located with respect to the dispensing channel **120** and the inlet **122** such that, in the case of a preload dispensing fault condition, one or more of the tablets will occlude the entrance sensor **84**. When this condition occurs prior to initiation of the forward flow **FF**, the entrance sensor **84** will provide a detection signal to the controller **42** indicating that the one or more tablets is/are at the entrance sensor **84**. In response to the detection signal from the entrance sensor **84** prior to initiating the forward flow **FF**, the controller **42** identifies the existence of the preload dispensing fault condition. Further in response, the controller **42** will thereafter open the reverse valve **146** to generate the reverse flow **FR** to force any tablets **T** lingering in the channel **120** back into the hopper chamber **112A**. In this manner, the channel **120** is cleared and the preload dispensing fault condition is removed prior to the onset of tablet dispensing.

[056] A preload dispensing fault may also occur wherein the preloaded tablet or tablets are disposed in the dispensing channel **120** between the entrance sensor **84** and the exit sensor **80** prior to actuation of the forward valve **142** to generate the forward flow **FF**. The preloaded tablets may not occlude the entrance sensor **84**. According to some embodiments of the present invention, preload dispensing fault conditions of this type are identified and corrected by continuously monitoring the entrance sensor **84** even when the bin **100** is idle. According to some embodiments, the entrance sensor **84** is continuously monitored at least from the end of the actuation of the reverse flow **FR** during calibration as discussed above to the start of the forward flow **FF** to begin a dispensing session (*i.e.*, the idle period). According to some embodiments, the entrance sensor **84** is also continuously monitored throughout the calibration period. According to some embodiments, the entrance sensor **84** is continuously monitored at all times. If a tablet is detected by the entrance sensor **84** during the idle period, the controller **42** identifies the existence of a preload dispensing

fault condition. The controller 42 may respond to the identified fault condition by generating the reverse flow FR to force any tablets lingering in the channel 120 back into the hopper chamber 112A. In this manner, the channel 120 is cleared and the preload dispensing fault condition is removed prior to the onset of tablet dispensing.

[057] The sensor system 102 may employ the following method to address a “tandem dispensing fault condition.” With reference to **Figure 9**, when a tandem dispensing fault condition is present, the controller 42 may generate the forward flow FF to dispense the tablets as discussed above with regard to the prior art single sensor systems. This may occur if the entrance sensor 84 is not relied upon to sense preloaded tablets or the tandem condition is not detectable because the configuration/locations of the tablets do not cause the sensor 84 to immediately start with a tablet detection. The outputs of the sensors 80, 84 are monitored by the controller 42 and compared. Each of the two tablets passes the entrance sensor 84 in immediate succession, which causes the entrance sensor to generate a single pulse P2 as represented by the signal pulse graph A) of **Figure 9**. The signal pulse P2 has a duration that is larger than that of a prescribed or average reference duration for a single tablet passing the sensor 84 during dispensing. Thereafter, the two tablets pass the exit sensor 80 in immediate succession, which causes the exit sensor 80 to generate one continuous, long duration signal pulse P4 as represented by the detector pulse graph B) of **Figure 9**. The signal pulse P4 has a duration that is larger than that of a prescribed or average reference duration for a single tablet passing the sensor 80 during dispensing. The controller 42 compares the durations of the signals P2, P4 with the corresponding expected or average signal pulse durations and also compares the time TBP between the pulses P2, P4 with the expected or average time between pulses for standard operation, and determines that a tandem dispensing fault condition has occurred. In response, the controller 42 may increment the system dispensed count by an appropriate amount and/or alert an operator. The expected or average signal pulse durations for the sensors 80, 84 and the expected or average time between the pulses of the sensors 80, 84 may be determined using average entrance, exit and nozzle velocities determined as described below.

[058] In some cases, a first tablet T lingers in the dispensing channel 120 during dispensing so that a second tablet T catches up to and collides with the first tablet before the first tablet is detected or completely detected by a counting sensor.

The second tablet travels down the channel **120** in contact with the first tablet so that the first and second tablets pass the counting sensor together, responsive to which the counting sensor generates a single, extended duration signal pulse. This condition may be referred to as a "collision dispensing fault condition". In prior art single sensor systems, the single, extended duration signal pulse may simply be counted as a single tablet. As a result, two tablets are actually dispensed from the outlet but the system tablet dispense count is only incremented by one tablet.

[059] In accordance with embodiments of the present invention, a collision dispensing fault condition can be identified and corrected by monitoring the exit sensor **80** and the entrance sensor **84**. More particularly, the outputs of the exit sensor **80** and the entrance sensor **84** are monitored by the controller **42** and compared. In the case of a collision dispensing fault condition, each of the two tablets passes the entrance sensor **84** in turn and with spacing between the tablets, which causes the entrance sensor **84** to generate two discrete signal pulses **P10**, **P12** in sequence over time, as represented by the signal pulse graph **A**) of **Figure 10**. These two pulses **P10**, **P12** have a duration corresponding to a typical single tablet. Thereafter, the two tablets pass the exit sensor **80** in immediate succession, which causes the exit sensor **80** to generate one long duration signal pulse **P14** as represented by the detector pulse graph **B**) of **Figure 10**. The controller **42** compares the signals **P10**, **P12**, **P14** from the sensors **80**, **84** and determines that a collision dispensing fault condition has occurred. In response, the controller **42** may increment the system dispensed count total by the appropriate amount (in this example, two). Alternatively, in response, the controller **42** may issue an alert to an operator or the like indicating that a tablet may have been dispensed but not counted.

[060] In some cases in prior art single sensor systems, a tablet that has been previously detected by a count sensor and counted by the sensor as dispensed is drawn back into or through the dispensing channel by a reverse drive gas flow **FR** (*i.e.*, the tablet is aspirated back into the dispensing channel or hopper chamber). This occurrence may be referred to as an "aspiration dispensing fault condition". In prior art single sensor systems, the system count will exceed the actual number of dispensed tablets.

[061] In accordance with embodiments of the present invention, an aspiration dispensing fault condition can be identified and corrected by monitoring the exit sensor

80 and the entrance sensor 84, and the direction of drive gas flow. More particularly, the outputs of the exit sensor 80 and the entrance sensor 84 are monitored by the controller 42 and compared. Each signal pulse from the exit sensor 80 will be accounted for if preceded by a corresponding signal pulse from the entrance sensor 84. Under normal (nonfault) conditions, each tablet drawn from the hopper 112A passes the entrance sensor 84 and then the exit sensor 80 and generates corresponding signal pulses in sequence. In the case of an aspiration dispensing fault condition, a tablet previously counted as dispensed passes the exit sensor 80, which causes the exit sensor 80 to generate a signal pulse P20 as represented by the detector pulse graph B) of Figure 11. Thereafter, the tablet passes the entrance sensor 84, which causes the entrance sensor 84 to generate a signal pulse P22 as represented by the detector pulse graph A) of Figure 11. The controller 42 determines that the drive gas flow was in the reverse direction when the pulses P20, P22 were generated and compares the signals P20, P22 from the sensors 80, 84. The controller determines that the exit signal pulse P20 did not have a corresponding preceding entrance sensor pulse and the exit sensor detection pulse P20 was triggered or generated prior to the entrance sensor detection pulse P22. From this, the controller 42 determines that an aspiration dispensing fault condition has occurred. In response, the controller 42 may decrement the system dispensing count total by one. Alternatively, in response, the controller 42 may issue an alert to an operator indicating that a tablet may have been counted and thereafter aspirated.

[062] In some cases in prior art single sensor systems, jams are detected using the single sensor, which is typically positioned proximate the outlet of the dispensing channel. If, when the forward drive gas flow is being generated, some prescribed length of time (*e.g.*, 1.0 second) passes without a tablet being detected by the single sensor, the system will issue a reverse drive gas flow in order to clear an upstream jam in the dispensing channel (*i.e.*, the presumed cause of the failure to detect a tablet at the sensor). However, because of the length of time required for a tablet to travel from the entrance, the reverse drive gas jet flow may be initiated while a tablet is in fact en route to the exit count sensor such that the tablet occludes the count sensor, reverses direction in the dispensing channel, and returns back to the hopper chamber. This occurrence may be referred to as a "tablet reversal dispensing fault condition". In prior art single

sensor systems, the tablet may be counted as dispensed and the reversal may not be registered so that the system count is increased over the actual number of tablets dispensed by one. Moreover, in some cases, the reversed tablet may be counted twice (once when passing the count sensor in the dispensing direction and once when passing the count sensor in the reverse direction).

[063] In accordance with embodiments of the present invention, a tablet reversal dispensing fault condition is prevented by triggering the reverse drive gas flow (jam clear) off of the entrance sensor **84** instead of the counting sensor **80**. More particularly, the controller **42** monitors the entrance sensor **84**. If a tablet is not detected by the entrance sensor **84** within a prescribed length of time (wait time) while the forward drive gas flow (*i.e.*, the dispensing flow) is being generated, the controller **42** will identify a tablet jam condition. Responsive to the tablet jam condition, the controller **42** will issue a jam clear (*i.e.*, open the reverse valve **146** to generate a burst or sustained reverse flow **FR**). In this manner, the entrance sensor **84** "guards" the exit sensor **80**.

[064] The sensor system **102** may additionally or alternatively employ the following method to identify and correct a tablet reversal dispensing fault condition by monitoring the exit sensor **80**, the entrance sensor **84**, and the direction of drive gas flow. The outputs of the exit sensor **80** and the entrance sensor **84** are monitored by the controller **42** and compared. In the case of a tablet reversal dispensing fault condition, a tablet passes the entrance sensor **84** (which causes the entrance sensor **84** to generate a typical duration signal pulse **P30** as represented by the detector pulse graph **A**) of **Figure 12**), thereafter passes the exit sensor **80** (which causes the exit sensor **80** to generate an extra long duration signal pulse (or two signal pulses as shown by the dotted line) **P32** as represented by the detector pulse graph **B**) of **Figure 12**), and thereafter again passes the entrance sensor **84** (which causes the entrance sensor **84** to generate a typical duration signal pulse **P34**). The controller **42** determines that the drive gas flow was in the forward direction during the pulse **P30** and in the reverse direction during the pulse **P34**, compares the signals **P30**, **P32**, **P34** from the sensors **80**, **84**, and determines that a tablet reversal dispensing fault condition has occurred. In response, the controller **42** may decrement the dispensing count total by one. Alternatively, in response, the controller **42** may issue an alert to an operator indicating

that a tablet may have been counted and thereafter reversed.

[065] While events such as those described above may be characterized by specific sequences of events, the sensor system **102** may also derive information about the events themselves or the dispensing system operation from the information embodied in the sensor signals (*e.g.*, in the sensor signal pulse trains), comparison between the outputs of the sensors **80**, **84**, and externally determined or known information about the tablets and tablet flow direction.

[066] The sensor system **102** may allow for measurement of speed and time related to tablet dispensing. According to some embodiments, the length of a complete prescribed tablet (hereinafter, "Tablet Length") is known. With reference to **Figure 13**, for each tablet dispensed through the channel **120**, the controller **42** will receive a detection signal pulse **JP** from the entrance sensor **84** and a detection signal pulse **CP** from the exit sensor **80**. The pulse **JP** has a duration or width **JPW** corresponding to the duration of occlusion of the sensor **84** by the tablet. Likewise, the pulse **CP** has a duration or width **CPW** corresponding to the duration of occlusion of the sensor **80** by the tablet. The controller **42** determines the velocity of each tablet through the outlet **124** (its "exit velocity") and the velocity of the tablet through the inlet **122** (its "entrance velocity") using the pulse widths **JPW**, **CPW** and the known Tablet Length. More particularly, the exit velocity can be calculated as:

$$\text{Tablet Length} / \text{Pulse width CPW} = \text{exit velocity}$$

[067] The entrance velocity can be calculated as:

$$\text{Tablet Length} / \text{Pulse width JPW} = \text{entrance velocity}$$

[068] Additionally, the controller can determine the velocity at which the tablet travels through the channel **120** (nozzle velocity) using the known distance ("sensor distance"; *e.g.*, the distance **D** (**Figure 5**)) between the operative trailing edge of the signal from the sensor **84** and the operative trailing edge of the signal from the sensor **80**, and the measured time between pulses (**TBP**) (*i.e.*, the duration between the end times **CP End** and **JP End** of the pulses **CP** and **JP** (*i.e.*, the trailing edges of the

pulses **CP** and **JP**), respectively). Using the trailing edges (**CP End** and **JP End**) may assist in determining when an event is over; however, the start times of the pulses **CP**, **JP** can be used instead. More particularly, the nozzle velocity can be calculated as:

$$\text{sensor distance} / (\text{CP End} - \text{JP End}) = \text{nozzle velocity}$$

[069] From these measurements and prescribed values, the controller **42** can "learn" or determine the average exit velocity, the average entrance velocity, and the average nozzle velocity for tablets dispensed through the channel **120**. These average values can be applied to specific events (*i.e.*, dispensed tablets) to identify or evaluate additional characteristics of the events.

[070] According to some embodiments, when the pulses **CP**, **JP** for a given tablet indicate that the tablet has passed through the channel **120** at the average nozzle velocity but one or both of the pulses **CP**, **JP** has a duration that is less than the average by more than a prescribed amount (*e.g.*, one or two standard deviations), the controller **42** will identify the tablet as a partial tablet (*i.e.*, a tablet having a length less than the prescribed or standard length for the tablets). Using the pulse duration or width measurements, the known tablet length, and the typical time between signal pulses, the sensor system **102** can determine the number of whole tablets and partial tablets that are dispensed, and even the sizes of the partial tablet fragments.

[071] According to some embodiments, when a detection signal pulse **CP**, **JP** from a sensor **80**, **84** has a duration that exceeds the average pulse for that sensor by more than a prescribed amount (*e.g.*, one or two standard deviations), the controller **42** will identify an exception event. The controller **42** may further evaluate and catalog the exception event using this and additional available performance information. The controller **42** may assess the measured data and compare the measured data to the expected data for known specific events to identify a specific event corresponding to the measured data. Once the event or event type is identified, the controller may perform appropriate corrective action to the count, if any exists. The controller **42** may incorporate the states of the valves **142**, **146** and/or the sequence in which the pulses from the sensors **80**, **84** occurred in determining and cataloging the exception event.

[072] The sensor system **102** can also provide real time statistics of dispensing

performance for the bin 100, as well as a record of the performance of the bin 100.

[073] While the sensor system has been described hereinabove with regard to the bin 100 and the dispensing system 40, sensor systems according to embodiments of the present invention may be used with bins and/or systems of other types and configurations. Sensor systems according to embodiments of the present invention may include sensors differently configured than the sensors 80, 84.

[074] While embodiments employing forced gas drive mechanisms are described herein, other embodiments of the present invention may employ other drive mechanisms in place of or in addition to forced gas. For example, the pharmaceutical articles may be forced in the forward and/or reverse direction by vibration and/or gravity.

[075] While various methods are described herein to identify dispensing fault conditions, these methods may also serve to confirm proper count conditions. More particularly, the lack of identification of a dispensing fault condition may be registered or affirm a valid count or count session. Accordingly, sensor systems as disclosed herein may provide improvements in count confidence.

[076] The foregoing is illustrative of the present invention and is not to be construed as limiting thereof. Although a few exemplary embodiments of this invention have been described, those skilled in the art will readily appreciate that many modifications are possible in the exemplary embodiments without materially departing from the novel teachings and advantages of this invention. Accordingly, all such modifications are intended to be included within the scope of this invention. Therefore, it is to be understood that the foregoing is illustrative of the present invention and is not to be construed as limited to the specific embodiments disclosed, and that modifications to the disclosed embodiments, as well as other embodiments, are intended to be included within the scope of the invention.

That which is claimed is:

1. A method for dispensing solid pharmaceutical articles using an apparatus including a housing and a sensor system, the housing defining a dispensing channel having a dispensing inlet and a dispensing outlet downstream of the dispensing inlet, the sensor system including first and second sensors spaced apart along the dispensing channel such that the second sensor is located downstream of the first sensor, the method comprising:
 - forcing at least one article along a path through the dispensing channel;
 - generating detection signals using the first and second sensors responsive to articles passing through the dispensing channel; and
 - using the detection signals from the first and second sensors to monitor dispensing performance of the apparatus.
2. The method of Claim 1 wherein the first sensor is located proximate the dispensing inlet and the second sensor is located proximate the dispensing outlet.
3. The method of Claim 1 including counting the articles passing through the dispensing channel using at least one of the first and second sensors.
4. The method of Claim 3 including:
 - counting the articles passing through the dispensing channel using the second sensor; and
 - detecting jams of the articles using the first sensor.
5. The method of Claim 1 including:
 - forcing articles through the dispensing channel in a forward direction toward the dispensing outlet; and
 - identifying a preload dispensing fault condition responsive to detecting the presence of an article at the dispensing inlet using the first sensor prior to forcing the articles through the dispensing channel in the forward direction.

6. The method of Claim 5 including, responsive to identifying the preload dispensing fault condition, forcing the article in the dispensing channel out of the dispensing channel in a reverse direction through the dispensing inlet.

7. The method of Claim 1 including:
forcing articles through the dispensing channel in a forward direction toward the dispensing outlet; and thereafter
identifying a tandem dispensing fault condition responsive to receiving a continuous detection signal from the second sensor having a duration that is larger than a reference signal duration.

8. The method of Claim 1 wherein using the detection signals from the first and second sensors includes comparing the detection signals from the first and second sensors to determine whether a dispensing fault condition has occurred.

9. The method of Claim 8 including:
forcing articles through the dispensing channel in a forward direction toward the dispensing outlet; and thereafter
identifying a collision dispensing fault condition responsive to detecting two apparent articles passing the first sensor and only a single corresponding apparent article thereafter passing the second sensor.

10. The method of Claim 8 including:
forcing articles through the dispensing channel in a forward direction toward the dispensing outlet; thereafter
forcing articles in the dispensing channel in a reverse direction toward the inlet; and
identifying an aspiration dispensing fault condition responsive to detecting an article passing the second sensor while forcing the article through the dispensing channel in the reverse direction.

11. The method of Claim 10 including subtracting the article from an article count responsive to identifying the aspiration dispensing fault condition.

12. The method of Claim 8 including:
 - forcing articles through the dispensing channel in a forward direction toward the dispensing outlet; thereafter
 - forcing articles in the dispensing channel in a reverse direction toward the inlet; and
 - identifying an article reversal dispensing fault condition responsive to:
 - detecting an article passing the first sensor while forcing the articles through the dispensing channel in the forward direction; thereafter
 - detecting the article at least partially passing the second sensor; and thereafter
 - detecting the article passing the first sensor while forcing the articles through the dispensing channel in the reverse direction.
13. The method of Claim 1 including using the detection signals from the first and second sensors to determine an average travel velocity for articles dispensed through the dispensing channel.
14. The method of Claim 13 including using the determined average travel velocity and detection signals from at least one of the first and second sensors to identify a partial article dispensed through the dispensing channel.
15. The method of Claim 13 including using the determined average travel velocity and detection signals from at least one of the first and second sensors to identify an exception event corresponding to a longer than average detection signal pulse.
16. The method of Claim 1 wherein forcing at least one article along the path through the dispensing channel includes generating at least one drive gas flow using a flow generator to force the at least one article along the path through the dispensing channel.

17. The method of Claim 16 including forcing the articles through the dispensing channel using a drive gas jet.
18. The method of Claim 16 including positively controlling a positive pressure source to provide the at least one drive gas flow.
19. The method of Claim 1 including dispensing the articles from a hopper chamber of the housing into the dispensing channel.
20. An apparatus for dispensing solid pharmaceutical articles, the apparatus comprising:
 - a) a housing defining a dispensing channel having a dispensing inlet and a dispensing outlet downstream of the dispensing inlet;
 - b) a drive mechanism to force the articles along a path through the dispensing channel between the dispensing inlet and the dispensing outlet; and
 - c) a sensor system including:
 - first and second sensors operative to detect articles passing through the dispensing channel; and
 - a controller to receive and use detection signals from the first and second sensors to monitor dispensing performance of the apparatus;wherein the first and second sensors are spaced apart along the dispensing channel such that the second sensor is located downstream of the first sensor.
21. The apparatus of Claim 20 wherein the first sensor is located proximate the dispensing inlet and the second sensor is located proximate the dispensing outlet.
22. The apparatus of Claim 20 wherein at least one of the first and second sensors is a counting sensor.
23. The apparatus of Claim 22 wherein:
 - the second sensor is the counting sensor; and

the first sensor is a jam detection sensor.

24. The apparatus of Claim 20 wherein the controller is configured to:
signal the drive mechanism to force articles through the dispensing channel in a forward direction toward the dispensing outlet; and
identify a preload dispensing fault condition responsive to detecting the presence of an article at the dispensing inlet using the first sensor prior to forcing the articles through the dispensing channel in the forward direction.
25. The apparatus of Claim 24 wherein the controller is configured to signal the drive mechanism to force an article in the dispensing channel out of the dispensing channel in a reverse direction through the dispensing inlet responsive to identifying the preload dispensing fault condition.
26. The apparatus of Claim 20 wherein the controller is configured to:
signal the drive mechanism to force articles through the dispensing channel in a forward direction toward the dispensing outlet; and thereafter
identify a tandem dispensing fault condition responsive to receiving a continuous detection signal from the second sensor having a duration that is larger than a reference signal duration.
27. The apparatus of Claim 20 wherein the controller is configured to compare the detection signals from the first and second sensors to determine whether a dispensing fault condition has occurred.
28. The apparatus of Claim 27 wherein the controller is configured to:
signal the drive mechanism to force articles through the dispensing channel in a forward direction toward the dispensing outlet; and thereafter
identify a collision dispensing fault condition responsive to detecting two apparent articles passing the first sensor and only a single corresponding apparent article thereafter passing the second sensor.
29. The apparatus of Claim 27 wherein the controller is configured to:

signal the drive mechanism to force articles through the dispensing channel in a forward direction toward the dispensing outlet; thereafter
signal the drive mechanism to force articles in the dispensing channel in a reverse direction toward the inlet; and
identify an aspiration dispensing fault condition responsive to detecting an article passing the second sensor while forcing the articles through the dispensing channel in the reverse direction.

30. The apparatus of Claim 29 wherein the controller is configured to subtract the article from an article count responsive to identifying the aspiration dispensing fault condition.

31. The apparatus of Claim 27 wherein the controller is configured to:
signal the drive mechanism to force articles through the dispensing channel in a forward direction toward the dispensing outlet; thereafter
signal the drive mechanism to force articles in the dispensing channel in a reverse direction toward the inlet; and
identify an article reversal dispensing fault condition responsive to:
detecting an article passing the first sensor while forcing the articles through the dispensing channel in the forward direction;
thereafter
detecting the article at least partially passing the second sensor;
and thereafter
detecting the article passing the first sensor while forcing the articles through the dispensing channel in the reverse direction.

32. The apparatus of Claim 20 wherein the controller is configured to compare the detection signals from the first and second sensors to determine an average travel velocity for articles dispensed through the dispensing channel.

33. The apparatus of Claim 32 wherein the controller is configured to use the determined average travel velocity and detection signals from at least one of the first and second sensors to identify a partial article dispensed through the dispensing

channel.

34. The apparatus of Claim 32 wherein the controller is configured to use the determined average travel velocity and detection signals from at least one of the first and second sensors to identify an exception event corresponding to a longer than average detection signal pulse.

35. The apparatus of Claim 20 wherein the first and second sensors are mounted on the housing.

36. The apparatus of Claim 20 wherein the drive mechanism includes a flow generator operable to generate at least one drive gas flow to force the articles along the path through the dispensing channel.

37. The apparatus of Claim 36 wherein the flow generator includes:
a jet aperture in fluid communication with the dispensing channel; and
a positive pressure source fluidly connected to the jet aperture to provide a drive gas jet to force the articles through the dispensing channel.

38. The apparatus of Claim 36 wherein the controller is operative to selectively control the at least one drive gas flow.

39. The apparatus of Claim 36 wherein the housing includes a hopper chamber in fluid communication with the dispensing channel and configured to hold the articles.

40. A method for dispensing solid pharmaceutical articles using an apparatus including a housing and a sensor system, the housing defining a dispensing channel having a dispensing inlet and a dispensing outlet downstream of the dispensing inlet, the sensor system including first and second sensors positioned along the dispensing channel, the method comprising:

forcing at least one article along a path through the dispensing channel;
generating detection signals using the first and second sensors

responsive to articles passing through the dispensing channel; and
comparing the detection signals from the first and second sensors to
determine whether a dispensing fault condition has occurred.

41. A method for dispensing solid pharmaceutical articles using an apparatus including a housing and a sensor system, the housing defining a dispensing channel having a dispensing inlet and a dispensing outlet downstream of the dispensing inlet, the sensor system including at least one sensor positioned along the dispensing channel, the method comprising:

forcing at least one article along a path through the dispensing channel;
generating detection signals using the at least one sensor responsive to
articles passing through the dispensing channel; and
using a duration of at least one of the detection signals from the at least
one sensor to determine whether a dispensing fault condition has occurred.

1/11

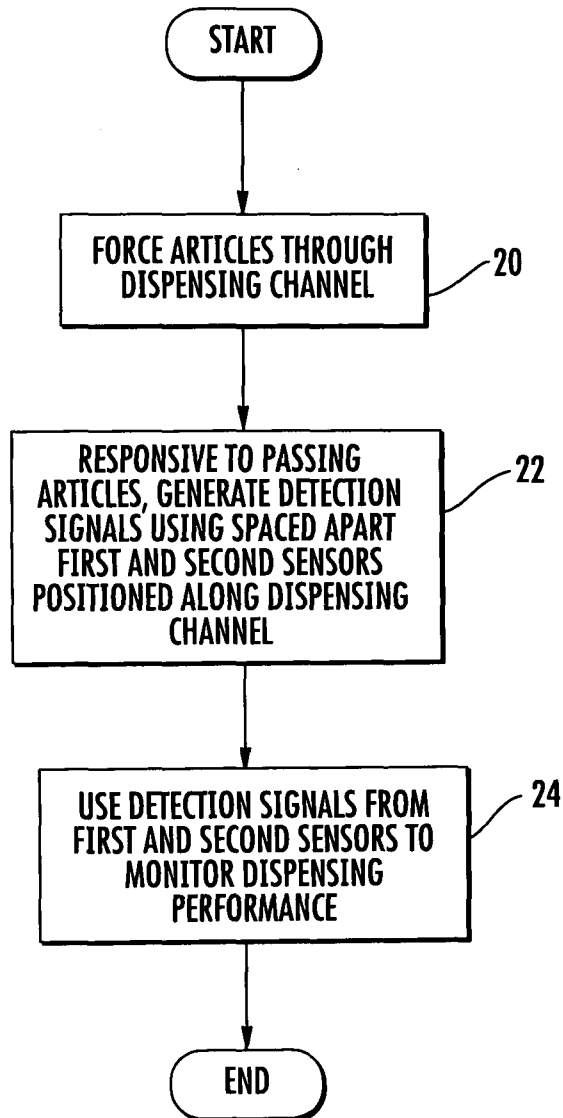

FIG. 1

2/11

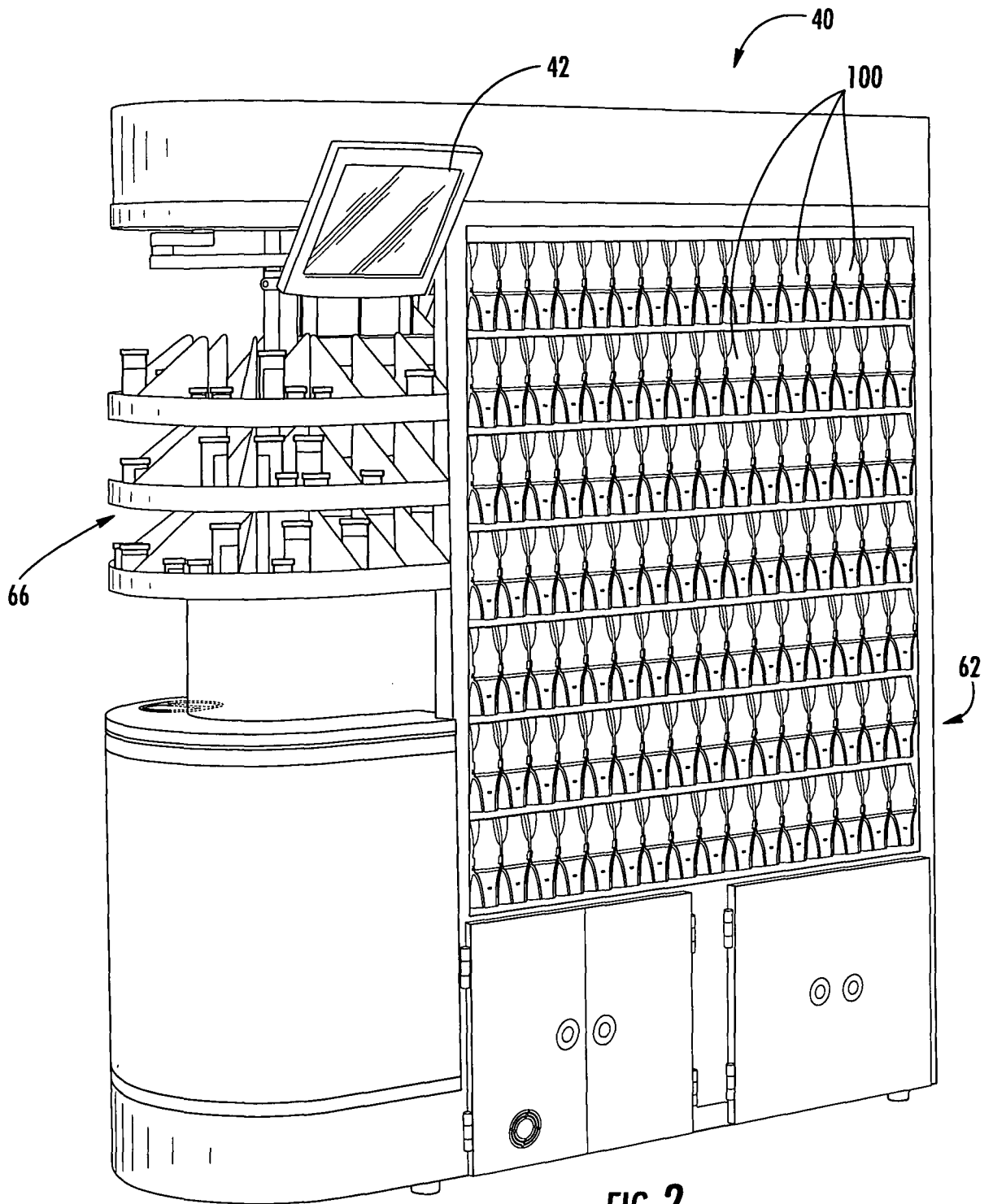

FIG. 2

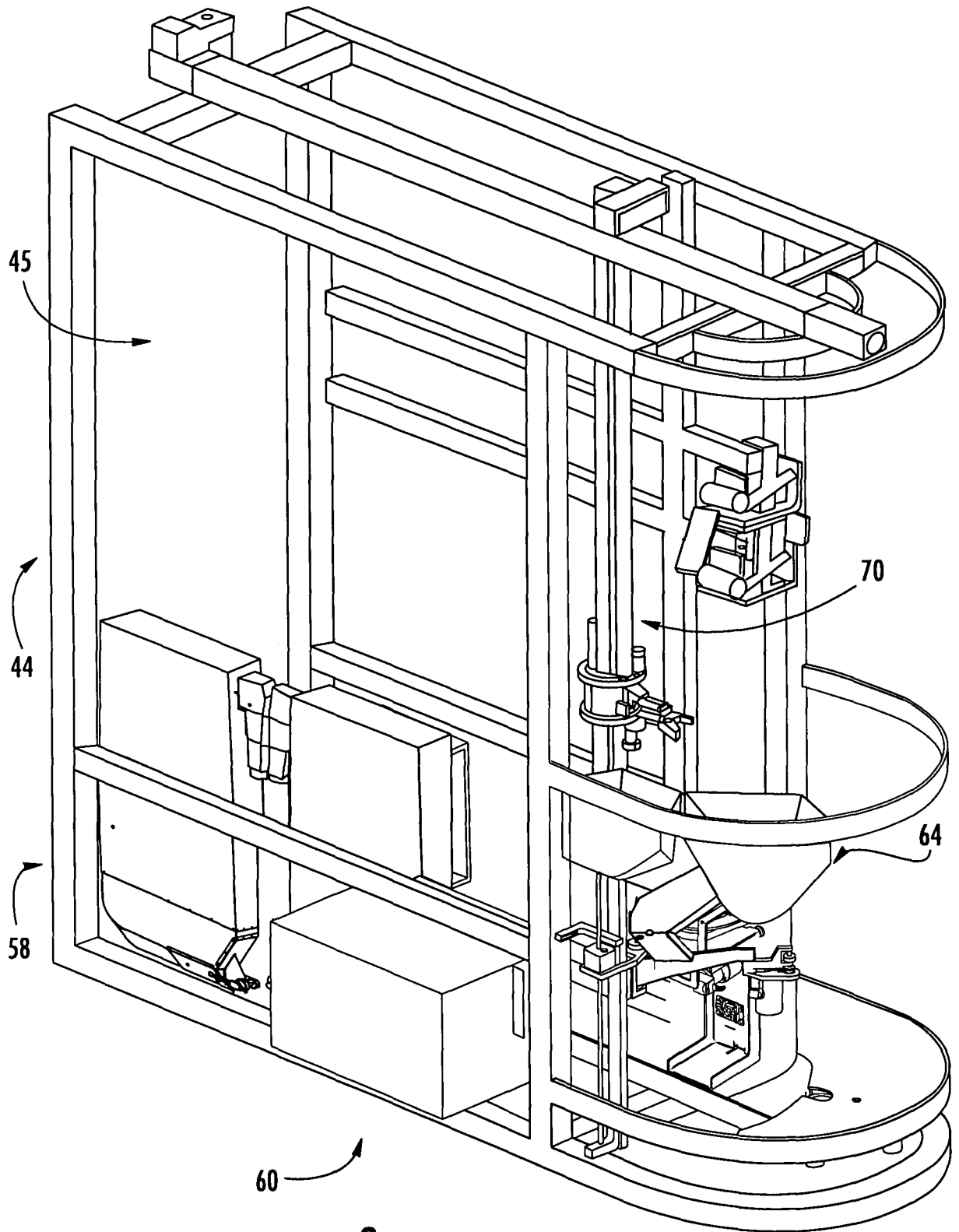

FIG. 3

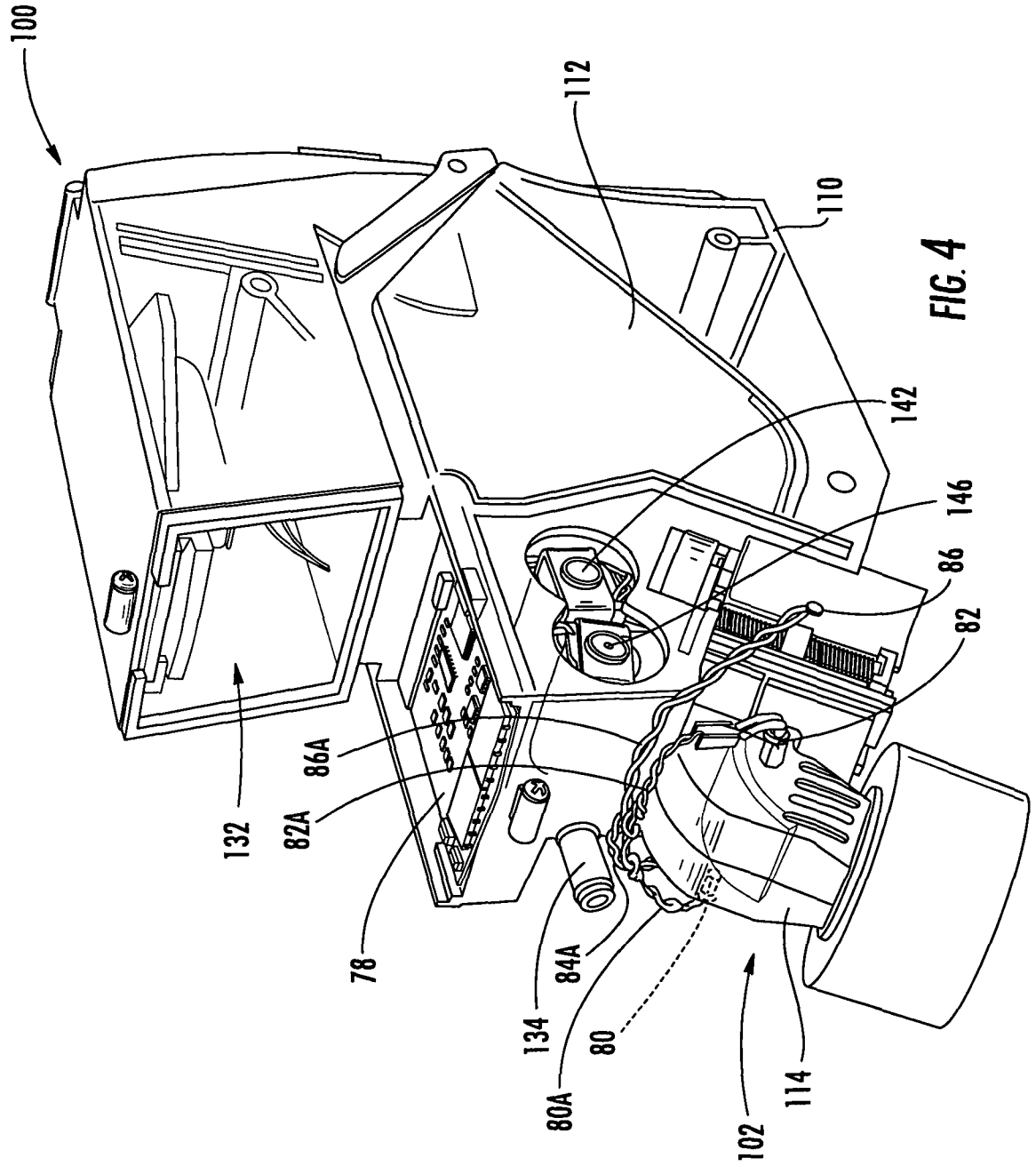
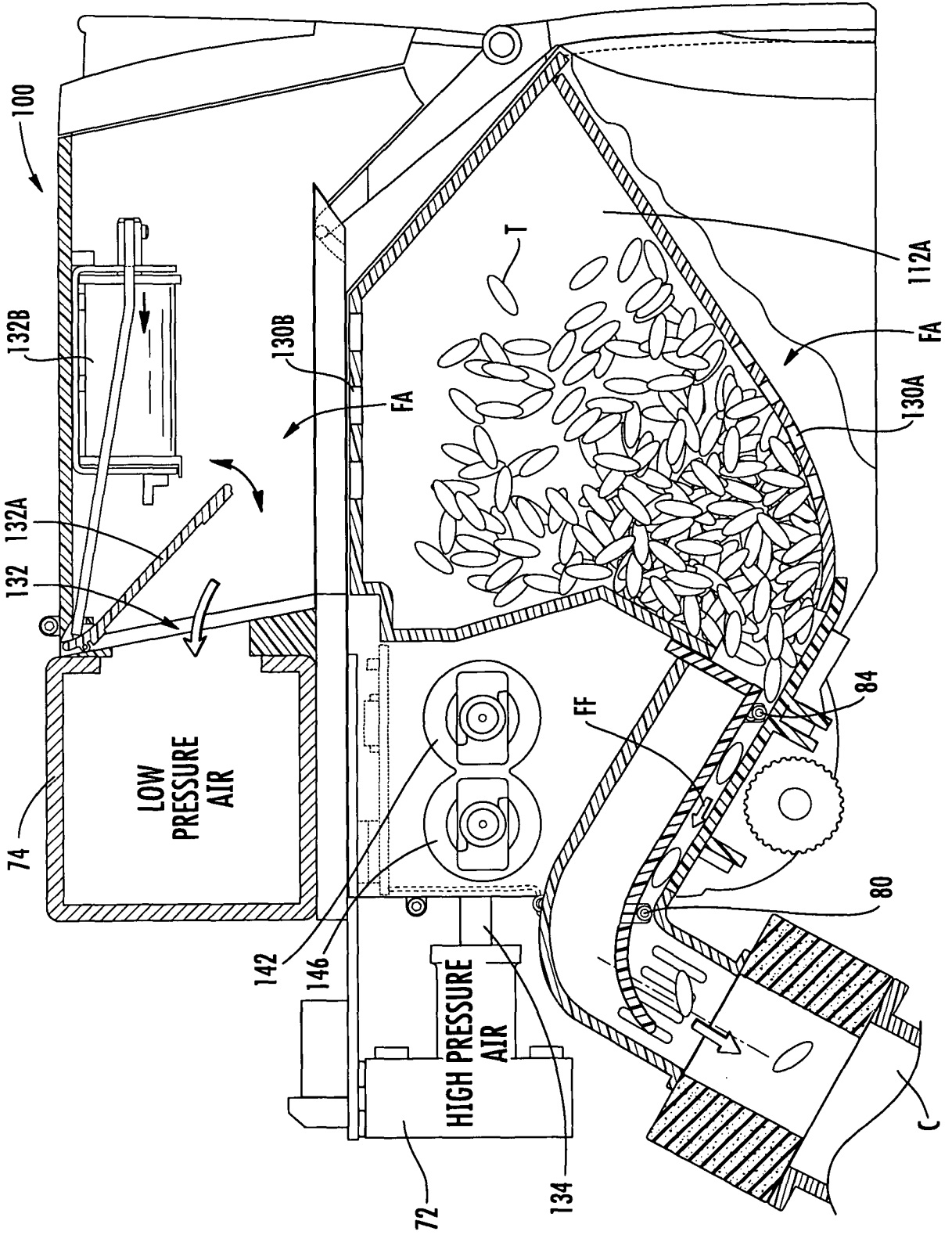
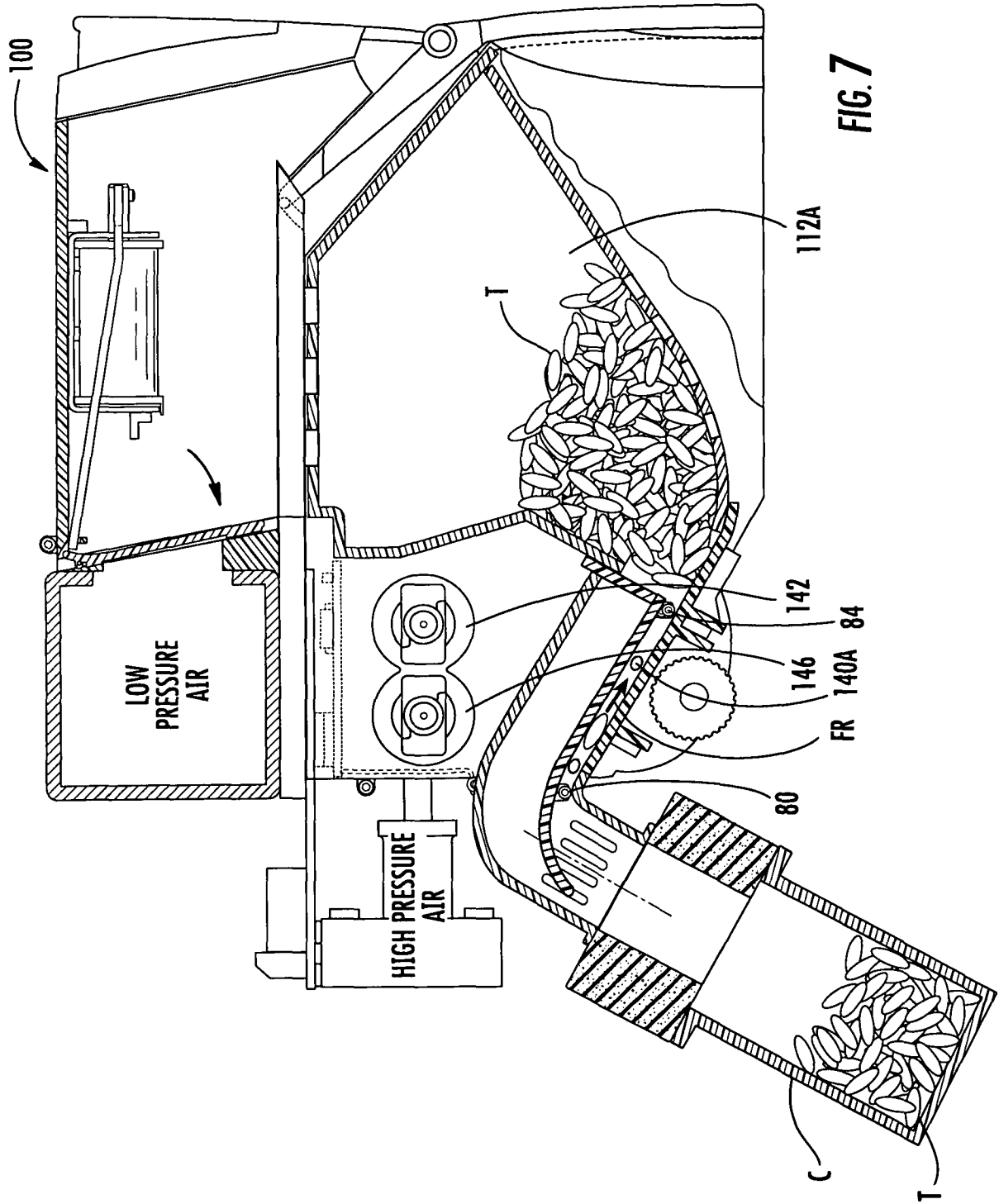

FIG. 6





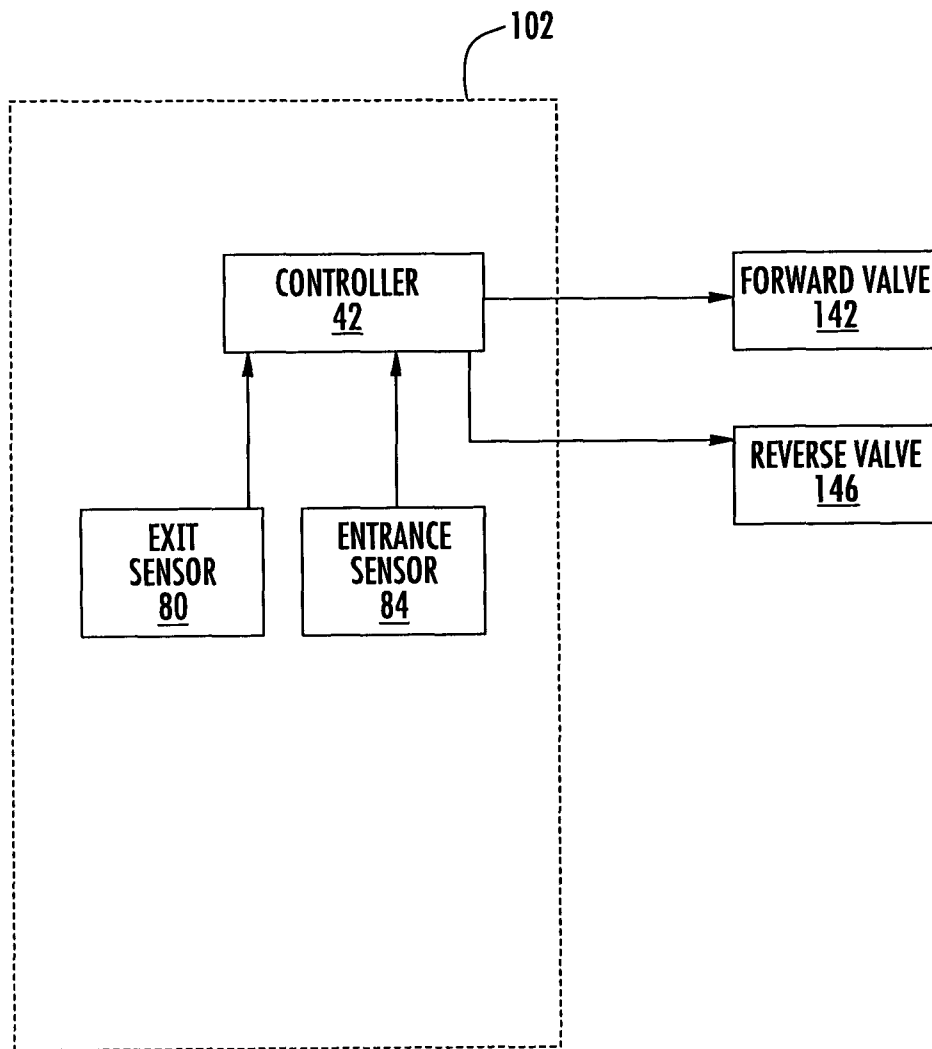

FIG. 8

9/11

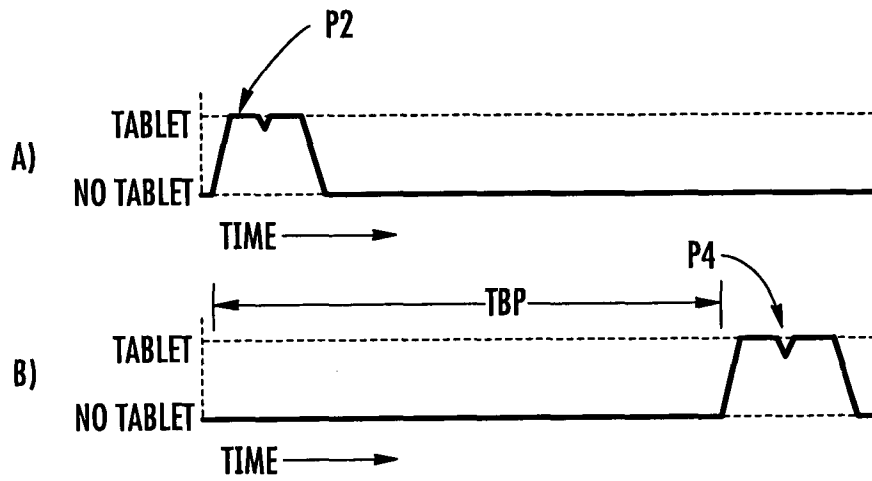

FIG. 9

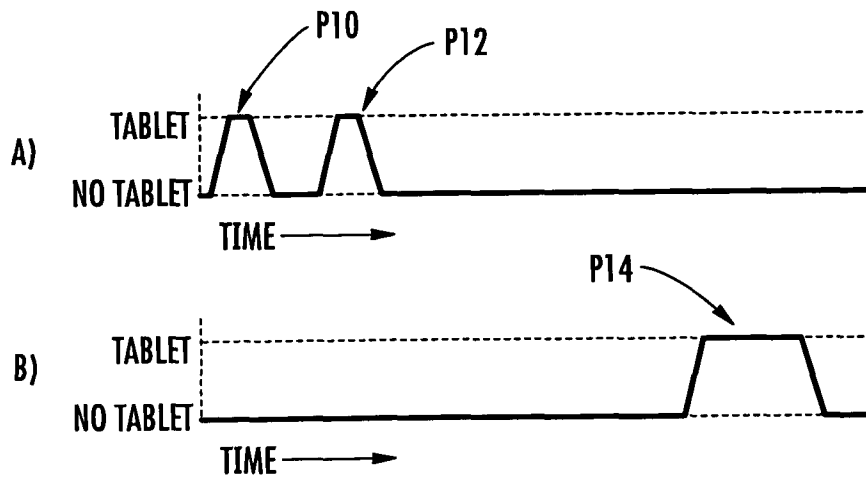

FIG. 10

10/11

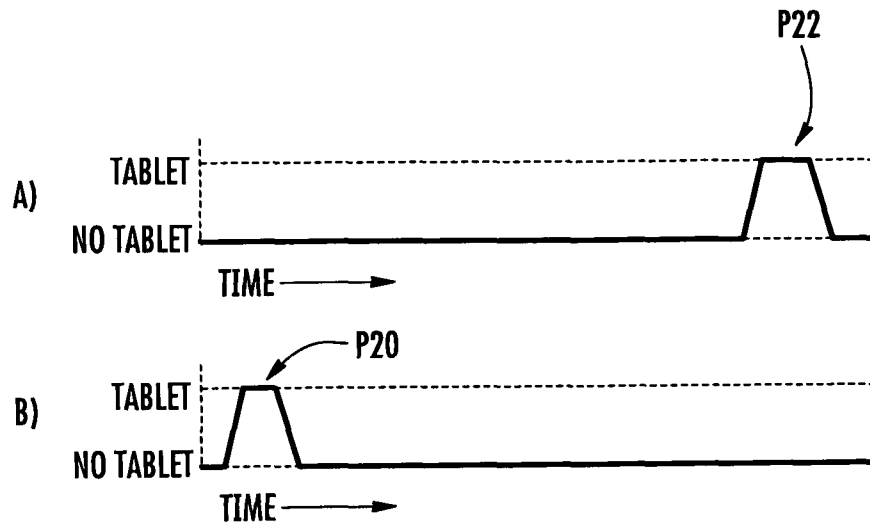

FIG. 11

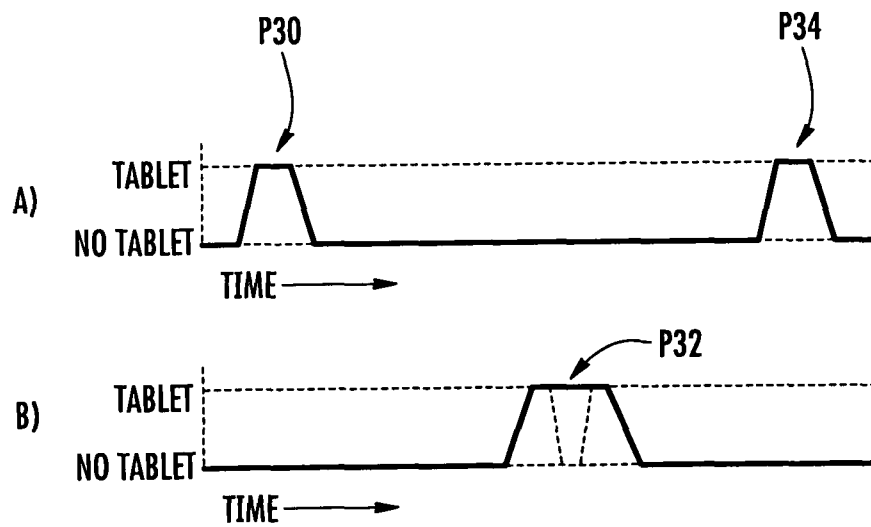

FIG. 12

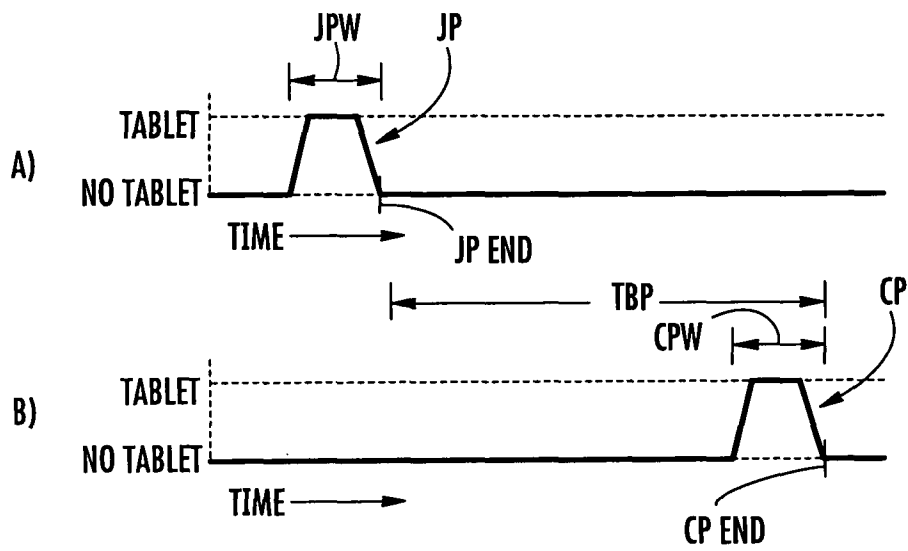

FIG. 13

INTERNATIONAL SEARCH REPORT

International application No
PCT/US2008/005297

A. CLASSIFICATION OF SUBJECT MATTER
INV. G07F11/44 G07F9/02

According to International Patent Classification (IPC) or to both national classification and IPC

B. FIELDS SEARCHED

Minimum documentation searched (classification system followed by classification symbols)
G07F

Documentation searched other than minimum documentation to the extent that such documents are included in the fields searched

Electronic data base consulted during the international search (name of data base and, where practical, search terms used)

EPO-Internal, WPI Data

C. DOCUMENTS CONSIDERED TO BE RELEVANT

Category*	Citation of document, with indication, where appropriate, of the relevant passages	Relevant to claim No.
X	US 2004/004085 A1 (WILLIAMS JEFFREY P [US] ET AL) 8 January 2004 (2004-01-08) abstract paragraph [0006] paragraph [0072] figure 28	1-41
X	----- US 5 671 262 A (BOYER JOSEPH H [US] ET AL) 23 September 1997 (1997-09-23) abstract column 3 - column 9; figures 1a-31	1-41
X	----- WO 03/008308 A (PARATA SYSTEMS LLC [US]; POLLARD JASPER [US]; MICHELLI RICHARD D [US];) 30 January 2003 (2003-01-30) page 4, line 21 - page 10, line 35 ----- -/--	1-41

Further documents are listed in the continuation of Box C.

See patent family annex.

* Special categories of cited documents :

- *A* document defining the general state of the art which is not considered to be of particular relevance
- *E* earlier document but published on or after the international filing date
- *L* document which may throw doubts on priority claim(s) or which is cited to establish the publication date of another citation or other special reason (as specified)
- *O* document referring to an oral disclosure, use, exhibition or other means
- *P* document published prior to the international filing date but later than the priority date claimed

- *T* later document published after the international filing date or priority date and not in conflict with the application but cited to understand the principle or theory underlying the invention
- *X* document of particular relevance; the claimed invention cannot be considered novel or cannot be considered to involve an inventive step when the document is taken alone
- *Y* document of particular relevance; the claimed invention cannot be considered to involve an inventive step when the document is combined with one or more other such documents, such combination being obvious to a person skilled in the art.
- *G* document member of the same patent family

Date of the actual completion of the international search

8 September 2008

Date of mailing of the international search report

15/09/2008

Name and mailing address of the ISA/
European Patent Office, P.B. 5818 Patentlaan 2
NL - 2280 HV Rijswijk
Tel. (+31-70) 340-2040, Tx. 31 651 epo nl,
Fax: (+31-70) 340-3016

Authorized officer

Lavin Liermo, Jesus

INTERNATIONAL SEARCH REPORT

International application No
PCT/US2008/005297

C(Continuation). DOCUMENTS CONSIDERED TO BE RELEVANT		
Category*	Citation of document, with indication, where appropriate, of the relevant passages.	Relevant to claim No.
X	US 2006/241807 A1 (DANIELS MATT [US] ET AL DANIELS MATTHEW P [US] ET AL) 26 October 2006 (2006-10-26) the whole document -----	1-41
A	US 5 768 327 A (PINTO ITZHAK [US] ET AL) 16 June 1998 (1998-06-16) column 4, line 54 - column 6, line 66 -----	1-41
A	US 5 884 806 A (BOYER JOSEPH H [US] ET AL) 23 March 1999 (1999-03-23) column 5 - column 12 -----	1-41
A	WO 99/61324 A (NEXTRX CORP [US]) 2 December 1999 (1999-12-02) abstract -----	1-41

INTERNATIONAL SEARCH REPORT

Information on patent family members

International application No

PCT/US2008/005297

Patent document cited in search report	Publication date	Patent family member(s)	Publication date	
US 2004004085	A1	08-01-2004	US 2005098569 A1	12-05-2005
			US 2005113968 A1	26-05-2005
			US 2005098570 A1	12-05-2005
			US 2005098571 A1	12-05-2005
			US 2005098572 A1	12-05-2005
			US 2005145640 A1	07-07-2005
			US 2005098573 A1	12-05-2005
US 5671262	A	23-09-1997	NONE	
WO 03008308	A	30-01-2003	AT 328823 T	15-06-2006
			BR 0211294 A	03-08-2004
			CA 2453404 A1	30-01-2003
			DE 60212139 T2	05-04-2007
			EP 1409381 A1	21-04-2004
			JP 4027891 B2	26-12-2007
			JP 2004535344 T	25-11-2004
			US 2004159669 A1	19-08-2004
			US 2003015555 A1	23-01-2003
US 2006241807	A1	26-10-2006	US 2008061075 A1	13-03-2008
			US 2008061077 A1	13-03-2008
			US 2008067190 A1	20-03-2008
			US 2008061078 A1	13-03-2008
US 5768327	A	16-06-1998	NONE	
US 5884806	A	23-03-1999	NONE	
WO 9961324	A	02-12-1999	AU 768321 B2	11-12-2003
			AU 4207699 A	13-12-1999
			CA 2333395 A1	02-12-1999
			EP 1121296 A2	08-08-2001
			JP 2002516165 T	04-06-2002
			NZ 508461 A	30-06-2003
			US 6219587 B1	17-04-2001
			US 2001002448 A1	31-05-2001
			US 2002095238 A1	18-07-2002