



(12) **EUROPEAN PATENT APPLICATION**

(88) Date of publication A3:
31.10.2001 Bulletin 2001/44

(51) Int Cl.7: **B28B 13/02, B28B 17/02,
B28B 3/02**

(43) Date of publication A2:
08.12.1999 Bulletin 1999/49

(21) Application number: **99201572.7**

(22) Date of filing: **20.05.1999**

(84) Designated Contracting States:
**AT BE CH CY DE DK ES FI FR GB GR IE IT LI LU
MC NL PT SE**
Designated Extension States:
AL LT LV MK RO SI

• **IRIS CERAMICA - SOCIETA' PER AZIONI**
41042 Fiorano Modenese (MO) (IT)

(30) Priority: **02.06.1998 IT RE980062**

(72) Inventor: **Cavazzoni, Gianpaolo,**
c/o Ariostea S.p.A.
42014 Castellarano (Reggio Emilia) (IT)

(71) Applicants:
• **Ariostea S.p.A.**
42014 Castellarano (Reggio Emilia) (IT)

(74) Representative: **Corradini, Corrado et al**
Studio Ing. C. CORRADINI & C. S.r.l.
4, Via Dante Alighieri
42100 Reggio Emilia (IT)

(54) **Device for feeding powders to a ceramic tile forming press**

(57) Device for feeding powders to a ceramic tile forming press, comprising a small feed hopper (7) positioned to overlie a loading carriage (5) provided with a loading compartment (51,52,53) containing a grid, and traversing between a position in which the compartment (51,52,53) lies below the small hopper (7) and a position in which the compartment lies above the mould impres-

sion (31,32,33), a powder distributor (21) moving with reciprocating movement above the mouth of the small hopper (7), and one or more large vessels or silos positioned upstream of the distributor to feed it with one or more types of powder, comprises upstream of the distributor tube (21) and downstream of the powder feed silos a rotary mixer (23) which receives powders from one or more of said silos.

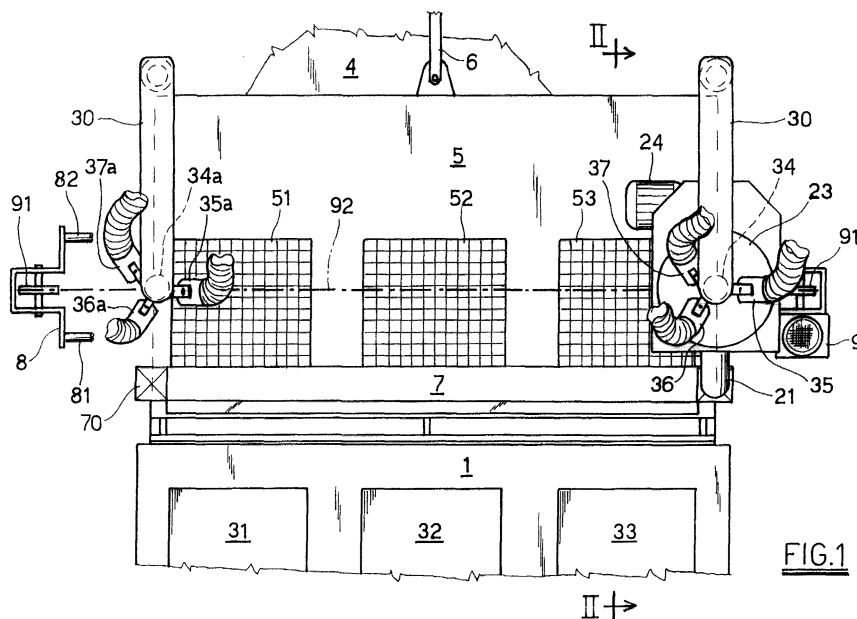

FIG.1



European Patent
Office

EUROPEAN SEARCH REPORT

Application Number
EP 99 20 1572

DOCUMENTS CONSIDERED TO BE RELEVANT			
Category	Citation of document with indication, where appropriate, of relevant passages	Relevant to claim	CLASSIFICATION OF THE APPLICATION (Int.Cl.6)
E	ES 2 133 066 A (EMILCERAMICA S P A) 16 August 1999 (1999-08-16) * the whole document *	1	B28B13/02 B28B17/02 B28B3/02
X	EP 0 605 930 A (MIRAGE CERAMICA SPA) 13 July 1994 (1994-07-13) * page 1, line 1 - line 17 * * page 6, line 31 - line 38; claims 32,33; figure 1 *	1-5,7,8, 10	
X	EP 0 822 044 A (IRIS CERAMICA SPA ;CERAMICHE DUAL S R L (IT)) 4 February 1998 (1998-02-04) * column 1, line 1 - line 23 * * column 5, line 28 - line 45; figure 1 *	1,7,8,11	
A	GB 2 216 839 A (TREND SET IND INTERNATIONAL IN) 18 October 1989 (1989-10-18) * page 1, paragraph 1 - paragraph 2 * * page 21, paragraph 4 - page 22, paragraph 1; figure 6 *	2,10	
A	US 2 097 613 A (CLEMETS BATCHELLER) 2 November 1937 (1937-11-02) * page 2, column 1, line 38 - page 2, column 2, line 37; figure 13 *	10	B28B B28C B01F
The present search report has been drawn up for all claims			TECHNICAL FIELDS SEARCHED (Int.Cl.6)
Place of search		Date of completion of the search	Examiner
THE HAGUE		5 September 2001	Ingelg rd, T.
CATEGORY OF CITED DOCUMENTS		T : theory or principle underlying the invention E : earlier patent document, but published on, or after the filing date D : document cited in the application L : document cited for other reasons & : member of the same patent family, corresponding document	
X : particularly relevant if taken alone Y : particularly relevant if combined with another document of the same category A : technological background O : non-written disclosure P : intermediate document			

EPO FORM 1503 03 92 (P04C01)

**ANNEX TO THE EUROPEAN SEARCH REPORT
ON EUROPEAN PATENT APPLICATION NO.**

EP 99 20 1572

This annex lists the patent family members relating to the patent documents cited in the above-mentioned European search report. The members are as contained in the European Patent Office EDP file on
The European Patent Office is in no way liable for these particulars which are merely given for the purpose of information.

05-09-2001

Patent document cited in search report		Publication date	Patent family member(s)	Publication date
ES 2133066	A	16-08-1999	IT RE950041 A	20-01-1997
EP 0605930	A	13-07-1994	IT 1262577 B	04-07-1996
			IT 1262578 B	04-07-1996
			AT 122278 T	15-05-1995
			DE 69300148 D	14-06-1995
			DE 69300148 T	02-11-1995
			ES 2072169 T	01-07-1995
EP 0822044	A	04-02-1998	IT RE960061 A	30-01-1998
GB 2216839	A	18-10-1989	AU 2889389 A	03-08-1989
US 2097613	A	02-11-1937	NONE	