



(72) NEELY, R. ALAN, US

(71) NEELY, R. ALAN, US

(51) Int.Cl.⁷ G06F 17/60

(30) 1997/09/09 (08/925,344) US

(54) **SYSTEME ELECTRONIQUE DE FACTURATION ET DE
PAIEMENT**

(54) **ELECTRONIC INVOICING AND PAYMENT SYSTEM**

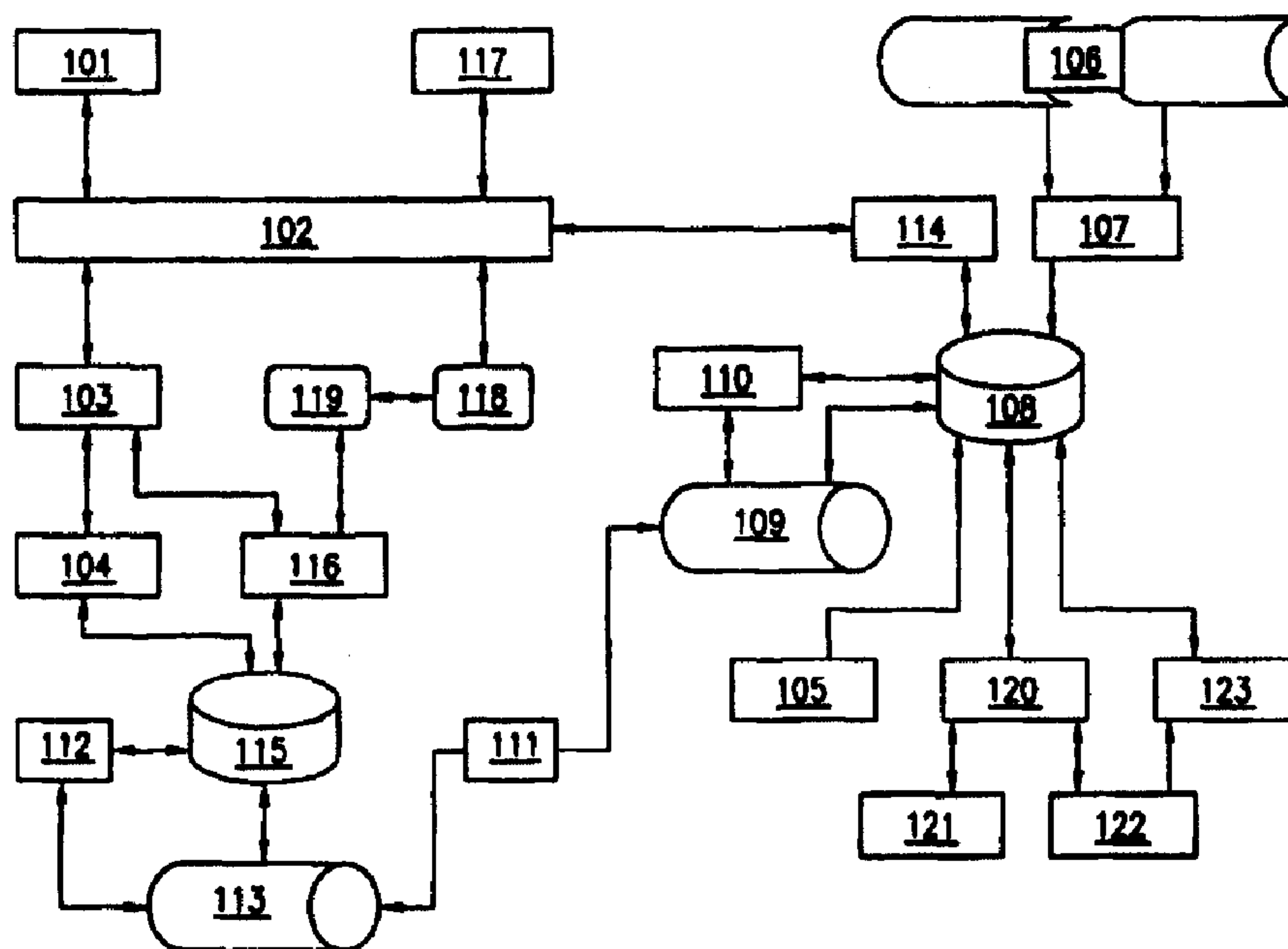

(57) L'invention concerne un système automatisé de facturation et de paiement, qui permet à un client de voir la facturation automatisée envoyée par un facturier. Le système comprend un dispositif électronique de présentation de facture, qui comporte un système de commande et un premier dispositif (101) électronique de communication. Il comprend également au moins un terminal d'autorisation à distance, qui comporte une interface client et un second dispositif (110) électronique de communication conçu pour communiquer fonctionnellement avec le premier dispositif (101) électronique de communication. Le système de

(57) A system for automated electronic invoicing and payment system for providing remote customer review of automated billing from an invoicer. The system includes invoice presentment electronics having a control system and first communication electronics (101). The system also includes at least one remote authorization terminal having a customer interface, the terminal having second communication electronics (110) adapted to operatively communicate with the first communication electronics (101). The control system of the invoice presentment electronics is adapted to provide billing data, regarding a customer invoice preauthorized



(21) (A1) **2,302,577**
(86) 1998/08/19
(87) 1999/03/18

commande du dispositif électronique de présentation de facture est conçu pour fournir au premier dispositif électronique de communication des données de facturation concernant la facture d'un client pour laquelle il y a une autorisation préalable de facturation automatisée, afin que ledit premier dispositif (101) transmette lesdites données au second dispositif (110) électronique de communication. L'interface client du terminal d'autorisation à distance est conçue pour présenter les données de facturation à un client et pour recevoir de celui-ci une réponse concernant lesdites données. La réponse indique soit l'acceptation des données de facturation, autorisant la facturation automatisée, soit la modification desdites données, demandant la modification de ladite facturation. L'acceptation peut être soit une réponse active donnée par le client, soit une réponse passive.

for automated billing, to the first communication electronics (101) for transmission to the second communication electronics (110). The customer interface of the remote authorization terminal is adapted to present the billing data to a customer and to receive a response relating to the billing data from the customer, the response indicating one of acceptance of the billing data or modification thereto.

PCTWORLD INTELLECTUAL PROPERTY ORGANIZATION
International Bureau

INTERNATIONAL APPLICATION PUBLISHED UNDER THE PATENT COOPERATION TREATY (PCT)

(51) International Patent Classification ⁶: G06F 17/60	A1	(11) International Publication Number: WO 99/13422 (43) International Publication Date: 18 March 1999 (18.03.99)
(21) International Application Number: PCT/US98/17154 (22) International Filing Date: 19 August 1998 (19.08.98) (30) Priority Data: 08/925,344 9 September 1997 (09.09.97) US (71)(72) Applicant and Inventor: NEELY, R., Alan [US/US]; 5618 Faye Drive, Greensboro, NC 27410 (US). (74) Agent: RILEE, Edward, W.; Rhodes Coats & Bennett, L.L.P., P.O. Box 2974, Greensboro, NC 27402 (US).		(81) Designated States: AL, AM, AT, AU, AZ, BA, BB, BG, BR, BY, CA, CH, CN, CU, CZ, DE, DK, EE, ES, FI, GB, GE, GH, GM, HR, HU, ID, IL, IS, JP, KE, KG, KP, KR, KZ, LC, LK, LR, LS, LT, LU, LV, MD, MG, MK, MN, MW, MX, NO, NZ, PL, PT, RO, RU, SD, SE, SG, SI, SK, SL, TJ, TM, TR, TT, UA, UG, UZ, VN, YU, ZW, ARIPO patent (GH, GM, KE, LS, MW, SD, SZ, UG, ZW), Eurasian patent (AM, AZ, BY, KG, KZ, MD, RU, TJ, TM), European patent (AT, BE, CH, CY, DE, DK, ES, FI, FR, GB, GR, IE, IT, LU, MC, NL, PT, SE), OAPI patent (BF, BJ, CF, CG, CI, CM, GA, GN, GW, ML, MR, NE, SN, TD, TG). Published <i>With international search report. Before the expiration of the time limit for amending the claims and to be republished in the event of the receipt of amendments.</i>

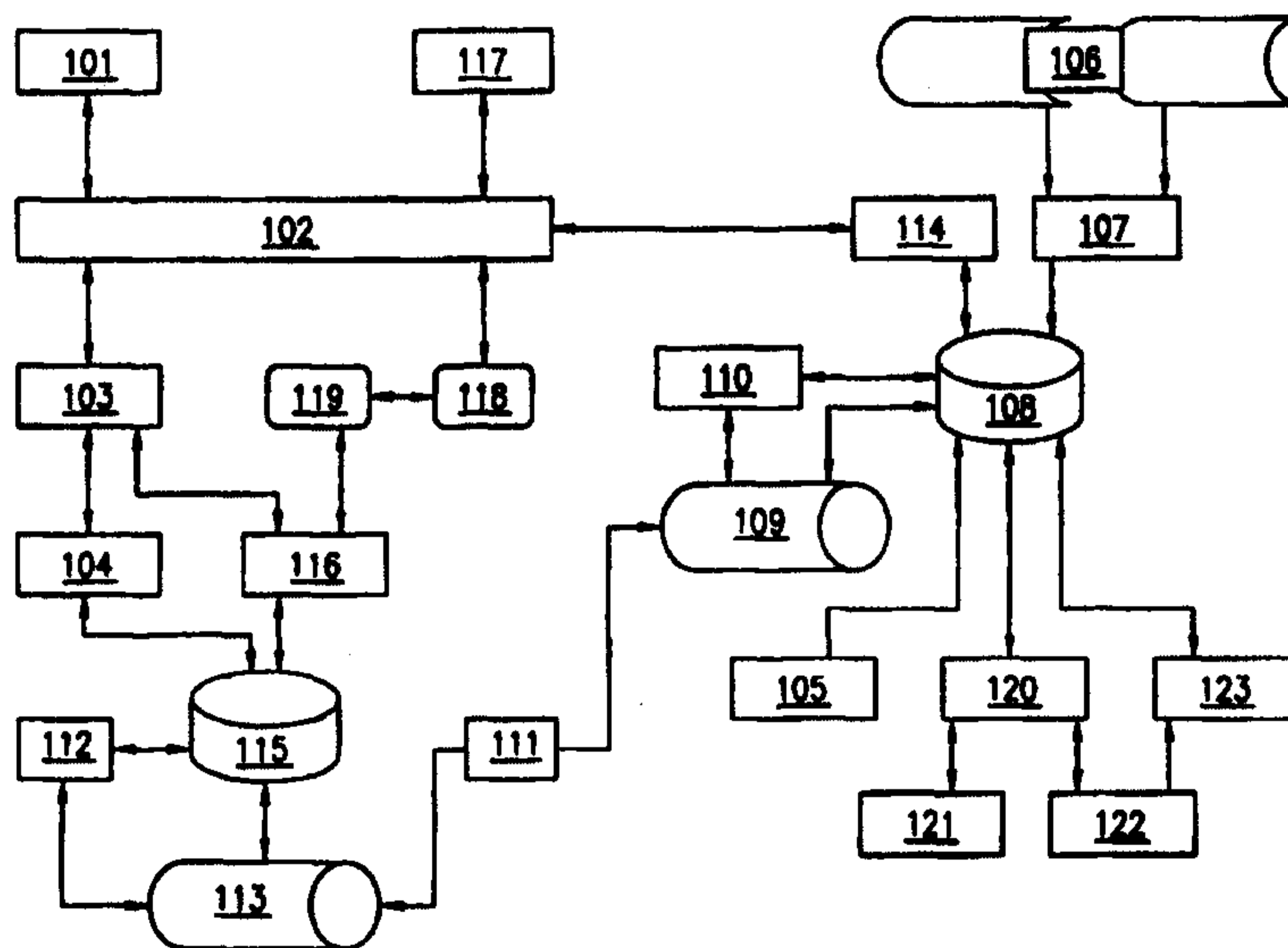
(54) Title: ELECTRONIC INVOICING AND PAYMENT SYSTEM**(57) Abstract**

A system for automated electronic invoicing and payment system for providing remote customer review of automated billing from an invoicer. The system includes invoice presentment electronics having a control system and first communication electronics (101). The system also includes at least one remote authorization terminal having a customer interface, the terminal having second communication electronics (110) adapted to operatively communicate with the first communication electronics (101). The control system of the invoice presentment electronics is adapted to provide billing data, regarding a customer invoice preauthorized for automated billing, to the first communication electronics (101) for transmission to the second communication electronics (110). The customer interface of the remote authorization terminal is adapted to present the billing data to a customer and to receive a response relating to the billing data from the customer, the response indicating one of acceptance of the billing data or modification thereto.

ELECTRONIC INVOICING AND PAYMENT SYSTEM

Background of the Invention

(1) Field of the Invention

5 The present invention relates generally to automated billing systems and, more particularly, to an automated payment system for presenting an electronic invoice to a customer for remote review and payment.

(2) Description of the Prior Art

10 Invoicing and payment collection has always been a very labor intensive and paper intensive process. Typically the process has involved an invoicer, usually a business, who prepares an invoice detailing the goods and services provided and the charges therefor. The invoice
15 is mailed to a customer who verifies the correctness of the invoice and returns a payment coupon of some type along with a paper check to the invoicer. The invoicer then submits the paper check to its bank for payment through, for example, the Automated Clearing House (ACH)
20 network. Other similar payment systems include writing a credit card number and endorsing and preauthorization to draft an account on a monthly basis up to preset limits, such as regularly paying utility bills from a checking account.

25 Attempts have been made to automate this process through the use of third party service providers who receive and transmit between the invoicer and the banks involved electronic information relating to payments due from a customer. Although these systems appear to
30 streamline the process, they, in fact, may add a great deal of complexity and no small amount of expense to the process. Such electronic systems are described in U.S. Patent Nos. 5,383,113, issued to Kight et al.; 5,283,829, issued to Anderson et al.; 5,220,501, issued to Lawlor et
35 al.; and 5,465,206, issued to Hilt et al., the disclosures of which are hereby incorporated by reference in their entireties.

 However, paper systems require that the invoice be

presented to the customer and, in addition, require that either that the customer present the paper check to the invoicer's bank either directly to the invoicer or indirectly to a lock box before payment is made from the customer's bank to the invoicer's bank.

Moreover, electronic systems require that the invoice be presented to a third party service provider and then to the customer or to the customer's bank and then to the customer and, in addition, require that the customer present the electronic payment back to the third party service provider before payment is made from the customer's bank to the invoicer's bank.

Thus, there exists a need for a simple, straight forward system and method of automated electronic invoicing and payment that directly involves the invoicer and the customer while, at the same time, does not require a third party service provider and can be customized to include pre-approved payments for invoices of a certain type or under a certain dollar threshold.

Summary of the Invention

The present invention is directed to an electronic invoicing and payment system for providing customers an opportunity to review and modify payment instructions carried out by the invoicer. The system includes invoice presentment electronics having a control system and first communication electronics. The system also includes at least one remote authorization terminal having a customer interface, the terminal having second communication electronics adapted to operatively communicate with the first communication electronics.

The control system of the invoice presentment electronics is adapted to provide billing data, regarding a customer invoice preauthorized for automated billing, to the first communication electronics for transmission to the second communication electronics.

The customer interface of the remote authorization terminal is adapted to present the billing data to a

customer and to receive a response relating to the
billing data from the customer, the response indicating
one of acceptance of the billing data for automated
billing or modification of the billing data for modifying
5 automated billing.

Accordingly, one aspect of the present invention is
to provide an automated electronic invoicing and payment
system for providing remote customer review of automated
billing from an invoicer. The system includes: (a)
10 invoice presentation electronics adapted to present
customer billing data and to request payment instructions
relating to automated billing to the customer; and (b) a
remote electronic customer authorization interface
adapted to: (i) receive the customer billing data and the
15 request for payment instructions from the invoice
presentation electronics; (ii) provide the customer
billing data and the request for payment instructions to
the customer; (iii) receive customer payment instructions
from the customer in response to the request for payment
20 instructions; and (iv) transmit the customer payment
instructions from the customer to the invoicer, the
payment instructions including at least an invoice
account number and an associated customer payment
account.

25 Another aspect of the present invention is to
provide a remote electronic customer authorization
interface for an automated electronic invoicing and
payment system for providing remote customer review of
automated billing from an invoicer. The system
30 including: (a) means for receiving customer billing data
and a request for payment instructions from the invoicer;
(b) means for receiving customer payment instructions
from the customer in response to the request for payment
instructions from the invoicer; and (c) means for
35 transmitting the customer payment instructions from the
customer to the invoicer, the payment instructions
including at least an invoice account number and an

associated customer payment account.

Still another aspect of the present invention is to provide an automated electronic invoicing and payment system for providing remote customer review of automated billing from an invoicer. The system includes: (a) invoice presentation electronics adapted to present customer billing data and to request payment instructions relating to automated billing to the customer; (b) a remote electronic customer authorization interface, said customer interface including: means for receiving customer billing data and a request for payment instructions from the invoicer; means for receiving customer payment instructions from the customer in response to the request for payment instructions from the invoicer; and means for transmitting the customer payment instructions from the customer to the invoicer, the interface adapted to: (i) receive the customer billing data and the request for payment instructions from the invoice presentation electronics; (ii) provide the customer billing data and the request for payment instructions to the customer; (iii) receive customer payment instructions from the customer in response to the request for payment instructions; and (iv) transmit the customer payment instructions from the customer to the invoicer, the payment instructions including at least a customer invoice account number and an associated customer payment account; and (c) a payment source, the invoice presentment electronics adapted to transmit the payment instructions to the payment source after customer review.

These and other aspects of the present invention will become apparent to those skilled in the art after a reading of the following description of the preferred embodiment when considered with the drawings.

Brief Description of the Drawings

FIGURE 1 is a schematic representation of various prior art invoicing systems;

5 FIGURE 2 is a schematic representation of a method for electronic invoicing and paying performed according to present invention; and

FIGURES 3A and 3B are schematic representations of an electronic invoicing and payment system constructed according to the present invention.

10 Description of the Preferred Embodiments

In the following description, like reference characters designate like or corresponding parts throughout the several views. Also in the following description, it is to be understood that such terms as
15 "forward", "rearward", "left", "right", "upwardly", "downwardly", and the like are words of convenience and are not to be construed as limiting terms.

Referring now to the drawings in general and Figure 1 in particular, it will be understood that the
20 illustrations are for the purpose of describing a preferred embodiment of the invention and are not intended to limit the invention thereto. Turning to Fig. 1, there is illustrated the current process used for paper invoice payment and automated invoice payment using a third party
25 service provider.

In the case of the paper invoice process, an invoicer 10 prepares a paper invoice 12 which is sent via mail to customer 20. After verifying that the invoice is correct customer 20 prepares a paper check 22 and returns
30 the paper check 22 to invoicer 10. Invoicer 10 then credits the account of customer 20 and submits check 22 with its other business receipts to invoicer bank 30. Invoicer bank 30 then interacts with customer bank 40 via the well-known ACH network to demand the funds from
35 customer's checking account and deposit those funds into the invoicer's checking account. This interaction follows a conventional, well known process represented by

PCT/US 98/17154
IPEA/US 95 OCT 1999

32, 42.

As discussed above, some period may elapse before
invoicer 10 receives check 22 from customer 20. This
process can be expedited somewhat if the check is sent
5 directly from customer 20 to invoicer bank 30. This
"lock box" process takes place through the use of a post
office box address on the invoice which sends the check
22 to invoicer bank 30 even though the address on the
invoice 12 may show the name of invoicer 10. In this
10 modified process, after receiving check 22, invoicer bank
30 will still go through the ACH network 32,42 before
funds are credited to invoicer's account.

In an attempt to automate this process, third party
service providers 54 have entered the scene. Here
15 invoicer 10 transmits an electronic data stream 14 to
service provider 54 containing all of the information
that normally is contained in a paper invoice. There is
then an electronic communication 50 between service
provider 54 and customer 20 for the purpose of notifying
20 customer 20 of the pending charge and, in some cases,
allowing the customer to approve of the charge against
its accounts. Service provider 54 then transmits payment
authorization 52 to customer bank 40. At the same time
service provider 54 may also transmit a message 56 to
25 invoicer 10 with notification of the payment
authorization 52.

After receiving authorization 52, customer bank 40
then sends payment to invoicer bank 30 through
conventional channels.

30 The non-bank service provider 54 may also be granted
access to the ACH network to direct draft via PPD
customer bank 40 on behalf of customer 20. In this case,
service provider 54 may receive funds from the customer
into the service provider checking account and then
35 disperse those funds to invoicer 10.

As can be seen from the complexity of Fig. 1, both
the conventional paper invoice process and the third

party service provider process are cumbersome, and time/labor intensive.

As best seen in Fig. 2, a method for electronic invoicing and paying is shown constructed according to the present invention. The method starts with the electronic presentment 50 of an invoice to customer 20. It should be understood that the term "presentment" as used herein does not include the specialized definition normally associated with commercial paper, i.e., the production of a negotiable instrument to a drawee. Rather, the term refers to providing via electronic means an "invoice" containing at least the same customer billing data typically included on a paper invoice. This electronic presentment may take place through the use of an Internet website, a bank ATM machine or through the use of a stand alone kiosk.

In a preferred embodiment, the invoice would also include, in addition to normal billing data, a request for payment instructions. This request provides the customer the opportunity to select either the bank account from which the invoice will be paid, or it provides the customer with the option to pay via a debit card, credit card, ATM, stored value card or some source of funds.

The invoice would include billing data such as the customer name, address, account number and e-mail address. The invoice may further include bill data typically included with a paper invoice to include the period covered by the invoice, a detail of the goods/services covered by the invoice, a total amount due and a payment due date.

In addition to the typical invoice information, the electronic invoice presentment may also include customer notices relating to changes in credit terms and the like.

Invoicer 10 may also include sales and promotional materials informing customer 20 of new products or sales on existing products.

After electronic invoice presentment 50, the customer provides an electronic authorization 52 to the invoicer 10 permitting customer's account to be charged.

5 This step eliminates the time and expense of preparing and mailing a paper check. Thus, invoicer 10 could be in a position to debit customer's bank account in as little as one day as opposed to the period required to receive a paper check 22.

10 The information included in this electronic authorization could include the customer invoice account number and an associated customer payment account. In a preferred embodiment, both these items of information are submitted simultaneously with the authorization. When pre-arranged instructions are made this information does
15 not need to be resubmitted each time.

Prior to providing the authorization for payment, customer 20 is provided with a number of options for changing the payment instructions to create modified payment instruction 52a. These modifications can range
20 from no modification at all in accepting all the payment terms contained in the presentment. Alternatively, customer 20 may be provided with any combination of the following options:

- 25 1) The customer may pay less than the amount due on the invoice for either unspecified reasons or for a specific reason such a dispute concerning a line item contained on the invoice.
- 30 2) The customer may elect to pay more than the amount due on the invoice.
- 3) The customer may elect to make a special payment, for example, an extra principal payment on a loan.
- 35 4) The customer may elect to change the date that the payment, via electronic transfer, will take place, provided that such date has not already

passed.

- 5) The customer may change the source of funds for the payment, i.e., from a primary checking account to a pre-authorized credit card.

5

Making any of these changes discussed above requires that the customer be authorized to do so by the invoicer.

The method described above may be carried out by an automated billing system depicted schematically in Fig. 3A which provides remote customer review of automated billing from an invoicer to include: (a) invoice presentation electronics 60 adapted to present customer billing data in request for payment instructions related to automated billing, and (b) an electronic customer authorization interface 84.

10
15

The customer interface receives customer billing data and request for payment instructions from the invoicer presentation electronics and provides those items to the customer. The interface also receives customer payment instructions in response to the request for payment instructions and transmits those instructions from the customer to the invoicer.

20

The invoice presentment electronics 60 may further include a control system 62 and first communication electronics 64. These components typically are located in an invoicer controlled facility.

25

At a customer facility, the system includes a remote authorization terminal 80 having second communication electronics 82 adapted to communicate with first electronic communications 64. Control system 62 coordinates the generation of the electronic invoice 50 containing at least all the billing information normally included on a traditional paper invoice along with a request for payment instructions. Control system then oversees the submission of that information from the first communication electronics 64 to the second communication electronics 82 for review by the customer.

30

35

Remote authorization terminal 80 is adapted to present the billing data to a customer and to an appropriate response relating to the billing data from the customer. The response indicates acceptance of the billing data without change for automated payment or modification of the billing data as described above. The customer interface 84 is further adapted to transmit this information to invoice presentment electronics 60.

The components of this system may be configured in a number of ways. For example, the customer accessible site may reside in an Internet website provided by invoicer for receiving the billing data and payment instructions from the customer. The website will be accessible from the customer electronic authorization interface 84. In this instance, the customer authorization interface 84 would include an Internet browser for accessing the customer accessible site.

Other alternatives for the electronic customer authorization interface include an automated teller machine (ATM), a remote kiosk, a personal computer, an interactive television device, or a telephone.

In the case of a telephone, the electronic customer authorization interface 84 could include either a well-known touch-tone telephone or a screen-based telephone.

In another embodiment, the electronic consumer authorization interface 84 is a digital computer with the billing data and the payment request instructions presented by e-mail to the customer with an e-mail reply for relaying customer payment instructions 52 to the invoice presentation electronics 60. The electronic customer authorization interface 84 could also include a display for presenting billing data and the request for payment instructions along with a customer actuatable input for receiving customer payment instructions.

In addition to the visual display, the electronic customer authorization interface 84 could further include audio electronics 85 and a speaker 86 for presenting

billing data and request for payment instructions to the customer. In this embodiment, the customer actuable input for receiving customer payment instructions may also feature a customer-spoken input.

5 The electronic customer authorization interface 84 may also be adapted to allow a customer to poll the invoice presentment electronics 60 to receive billing data and payment request instructions.

10 The automated billing system of the present invention includes submitting billing data from an invoicer to a customer for remote customer review and acceptance/modification and the transmission of those items to the invoicer. The billing information 50 that may be submitted to the customer includes any combination
15 of the following items:

- payment due date
- amount due
- detail of goods/services provided during a
20 billing period
- late charges
- account information
- customer information to include customer name, customer address, and customer account
25 identifier (the account identifier could include a customer number and/or an account number)
- invoice identifier, e.g., invoice number

30 The invoice presentment electronics 60 may include a memory device to store invoice information relating to customer bills and account information relating to financial institutions associated with the customer. That is, the customer may have the option of selecting
35 from a number of accounts a specific account from which funds are drafted to pay the invoice.

The memory device and the invoice presentment electronics 60 may also include information relating to a pre-authorized payment instruction for automated payment of the billing amount set out in the billing information from an account set out in the account information. If pre-authorized payment instructions are used, the request for payment instructions 50 originating in the invoice presentment electronics 60 may query the customer for acceptance of those instructions with or without modification. To accomplish such a modification, the customer authorization interface 84 may further include an editor for modifying the pre-authorized payment instructions.

The overall operation of the present invention can best be understood by referring to Figure 3B. The invoicer's customer can access the system through any remotely attached computing device 101 and communicates with the invoicer systems through a public or private network 102. A webserver or communications processor of some kind 103 manages on-line communications between the customer and application systems that allow the customer to begin the provisioning process. The customer is presented electronically data input forms to complete by a provisioning application program 104 which also may validate whether the data input by the customer is valid according to the invoicer's records as contained in the Legacy systems. After determining whether customer and financial account records are accurate, the invoicer activates the customer for electronic invoice presentment and remittance.

An electronic mail message or traditional letter may be sent to the customer with information that allows the customer to access the system, such as an account number and/or password.

During the next invoicing cycle for this customer, appropriate data, such as Legacy print data and Legacy automatic payment 106 is acquired. Legacy print data is

data that would normally be sent to a printer to prepare customers' invoices on paper. Legacy automatic payment data are records that are typically created by the invoicer that allow the invoicer to initiate payment based on pre-authorized arrangements with the customer. Payment records would include those formatted for automatic funds transfer from checking or savings accounts (ACH format data), debit transactions to credit cards, debit cards, or stored value cards. Files intended for transfer to ATM networks are also anticipated.

In acquiring the data for the product, Legacy data is sorted, parsed, extracted by an application program 107 and appropriate control data is maintained for reporting on operations. An application program 108 loads data into a relational database 109 for monthly processing. In the preferred embodiment, two separate computers may be used for additional security over sensitive financial data such as account numbers or authorization codes. As a further security measure, the invoicer may choose to configure the product using a computer 110 located behind the invoicer's firewall security device and connected by a secured network 111 to the webserver hosting computer 112.

Invoice presentment data and subsets of data on financial arrangements are made available for presentment by transfer of data using immediate transfer, for example by way of an encrypted, remote stored procedure within the database 109 or by a batch transfer.

Once data to be made available electronically has been accurately loaded to the webserver database 113, an application program 114 sends an electronic mail message to the customer announcing the availability of the monthly invoice and providing some summary of data. Since electronic mail account data may be invalid or services might be otherwise inoperative, the application program 114 is adapted to prepare data to be sent by the

US Postal Service, fax or other means. A front-end processor 115 contains a template necessary to present the invoice and default payment arrangements 116 in the manner that the invoicer desires. The webserver 103
5 hosts an interactive session in which the customer accesses their invoice. The customer may choose to modify pre-arranged payment arrangements. As an example, the customer may change the amount to pay, the date for payment and changing the source of funds for the payment,
10 from a personal checking account to another invoicer-approved source, such as a credit card. These arrangements 114 are stored on the webserver database 113.

In the preferred embodiment, the customer could also
15 use a telephone 117 connected to a network 102 and a PBX telephone processing switch 118 to pass data to and from a voice response unit 119. The customer could call into hear information about his invoice and signal changes to pre-existing arrangements, either through touch-tone
20 entry or speech recognition. These changes are processed by the front end processor 115 and recorded in the data base just like remote-computer-based entries.

On each day that the invoicer transfers payment data to banks or financial transaction processing services, an
25 application program 120 is executed to identify customers in the webserver database 113 that have payments scheduled. Data from the webserver is transferred for processing on the second computer 110 and combined with the data containing the pre-authorized, payment
30 arrangements which was initially stored in the relational database 109. Based on the customer's instructions, records are modified or might be deleted and recreated if a change in funding source is requested. Data is then formatted to interface back the invoicer's Legacy systems
35 121, for example, simulating the normal file format for the invoicer's lockbox processing.

Data 122 is transferred to the invoicer's bank or to

a third party that processes financial transactions. An application program 123 records those instances when a customer's data within a processing batch is returned for insufficient funds or incorrect account data so that the correct payment history for a customer can be maintained.

The security provisions of the product allow an exclusively invoicer-focused delivery of electronic invoice presentment and payment arrangements. Although the preferred embodiment anticipates that an invoicer may choose to outsource webserver hosting or webserver and remittance processing to an outside company on behalf of the invoicer, the service to customers would be provided so that the customer would not normally be aware that the invoicer was not actually operating the product directly.

Certain modifications and improvements will occur to those skilled in the art upon a reading of the foregoing description. It should be understood that all such modifications and improvements have been deleted herein for the sake of conciseness and readability but are properly within the scope of the following claims.

We Claim:

1. An automated electronic invoicing and payment system for providing remote customer review of automated billing from an invoicer, said system comprising:
 - 5 (a) invoice presentation electronics adapted to present customer billing data for customer review and to request payment instructions relating to automated billing to said customer; and
 - 10 (b) a remote electronic customer authorization interface adapted to:
 - 15 (i) receive the customer billing data for customer review and the request for payment instructions from said invoice presentation electronics; (ii) provide the customer billing data for customer review and the request for payment instructions to the
 - 20 customer; (iii) receive customer payment instructions from the customer in response to the request for payment instructions; and (iv) transmit the customer payment instructions from the customer directly to said invoicer, said payment instructions including at least a customer invoice
 - 25 account number and an associated customer payment account.
2. The system according to Claim 1 further including a payment source, said invoice presentment
30 electronics adapted to transmit the payment instructions to the payment source after customer review.
3. The system according to Claim 2, wherein said
35 payment source is a clearing house.
4. The system according to Claim 3, wherein said clearing house is a courier.
5. The system according to Claim 3, wherein said

clearing house is a payment network.

6. The system according to Claim 2, wherein said payment instructions include transmission date.

5

7. The system according to Claim 2, wherein said payment instructions include amount to draft from customer associated financial institution.

10

8. The system according to Claim 2, wherein said payment instructions include account information associated with the customer from which to draft payment.

15

9. The system according to Claim 2, wherein said payment instructions include account information associated with the invoicer from which to deposit payment.

20

10. The system according to Claim 1, wherein said billing data includes invoicer billing information.

11. The system according to Claim 10, wherein said billing information includes a due date.

25

12. The system according to Claim 10, wherein said billing information includes an amount due.

30

13. The system according to Claim 10, wherein said billing information includes a list of goods or services provided during a billing period.

14. The system according to Claim 10, wherein said billing information includes a late charge.

35

15. The system according to Claim 10, wherein said billing information includes account information.

16. The system according to Claim 1, wherein said billing data includes customer information.

5 17. The system according to Claim 16, wherein said customer information includes customer name.

18. The system according to Claim 16, wherein said customer information includes customer address.

10 19. The system according to Claim 16, wherein said customer information includes account information for the customer.

15 20. The system according to Claim 1, wherein said billing data includes a customer account identifier.

21. The system according to Claim 1, wherein said billing data includes an invoice identifier.

20 22. The system according to Claim 1, wherein said invoice presentment electronics includes invoice information relating to customer bills and account information relating to financial institutions associated with the customer from which payments may be drafted.

25 23. The system according to Claim 22, wherein said invoice presentment electronics further includes preauthorized payment instructions for automated payment of a billing amount set out in said billing information from an account set out in said account information.

30

24. The system according to Claim 23, wherein the request for payment instructions from said invoice presentment electronics query the customer if the preauthorized payment instructions are desired for the billing data presented.

35

25. The system according to Claim 23, wherein the request for payment instructions from said invoice presentment electronics query the customer if the preauthorized payment instructions need modification for the billing data presented.

26. The system according to Claim 23, wherein said customer authorization interface includes an editor for modifying the preauthorized payment instructions.

27. The system according to Claim 22, wherein the account information includes account information from a plurality of financial institutions and the request for payment instructions query the customer to select the financial institution from which to draft payment for an associated customer bill.

28. The system according to Claim 27, wherein said invoice presentment electronics includes a preauthorized default identifying the financial institution from which to draft payment for said associated customer bill.

29. The system according to Claim 28, wherein said electronic customer authorization interface is adapted to receive a customer input to accept the preauthorized default.

30. The system according to Claim 28, wherein said electronic customer authorization interface is adapted to receive a customer input to modify the preauthorized default.

31. The system according to Claim 1, wherein said request for payment instructions include billing information selected from the group consisting of amount due, time of payment, account from which to draft payment.

32. The system according to Claim 31, wherein said customer authorization interface is adapted to modify the billing information to change one or more of the group consisting of amount due, time of payment and account from which to draft payment.

33. The system according to Claim 1, wherein said billing data include notices for the customer.

34. The system according to Claim 1, wherein said billing data include advertising information directed towards the customer.

35. The system according to Claim 1, wherein said billing data include control information.

36. A remote electronic customer authorization interface for an automated electronic invoicing and payment system for providing remote customer review of automated billing from an invoicer, said system comprising:

- (a) means for receiving customer billing data for customer review and a request for payment instructions from said invoicer;
- (b) means for receiving customer payment instructions from the customer in response to said request for payment instructions from said invoicer; and
- (c) means for transmitting the customer payment instructions from the customer directly to said invoicer, said payment instructions including at least a customer invoice account number and an associated customer payment account.

37. The system according to Claim 36, wherein said

payment instructions include a date to draft payment.

38. The system according to Claim 36, wherein said payment instructions include a amount of invoice.

5

39. The system according to Claim 36, wherein said invoicer provides a customer accessible site for receiving said billing data and said request for payment instructions, said site accessible from said electronic customer authorization interface.

10

40. The system according to Claim 39, wherein said customer accessible site is an Internet site and said electronic customer authorization interface includes a browser for accessing said customer accessible site.

15

41. The system according to Claim 39, wherein said electronic customer authorization interface is an automated teller machine.

20

42. The system according to Claim 39, wherein said electronic customer authorization interface is a remote kiosk.

25

43. The system according to Claim 39, wherein said electronic customer authorization interface is a personal computer.

30

44. The system according to Claim 39, wherein said electronic customer authorization interface is an interactive television.

35

45. The system according to Claim 39, wherein said electronic customer authorization interface is a telephone.

46. The system according to Claim 39, wherein said

5 electronic customer authorization interface is a
computer, said billing data and said request for payment
instructions are presented by e-mail to the customer and
the customer payment instructions are provided by a
customer e-mail.

10 47. The system according to Claim 39, wherein said
electronic customer authorization interface includes a
display for presenting said billing data and said request
for payment instructions and a customer actuatable input
for receiving customer payment instructions.

15 48. The system according to Claim 39, wherein said
electronic customer authorization interface includes
audio electronics and a speaker for presenting said
billing data and said request for payment instructions
and a customer actuatable input for receiving customer
payment instructions.

20 49. The system according to Claim 39, wherein said
electronic customer authorization interface is adapted to
allow a customer to poll said invoice presentment
electronics to receive said billing data and said request
for payment instructions.

25 50. An automated electronic invoicing and payment
system for providing remote customer review of automated
billing from an invoicer, said system comprising:

- 30 (a) invoice presentation electronics adapted
to present customer billing data for
customer review and to request payment
instructions relating to automated billing
to said customer;
- 35 (b) a remote electronic customer authorization
interface, said customer interface
including: means for receiving customer
billing data for customer review and a
request for payment instructions from said

invoicer; means for receiving customer
payment instructions from the customer in
response to said request for payment
instructions from said invoicer; and means
5 for transmitting the customer payment
instructions from the customer to said
invoicer, said interface adapted to: (i)
receive the customer billing data for
customer review and the request for
10 payment instructions from said invoice
presentation electronics; (ii) provide the
customer billing data for customer review
and the request for payment instructions
to the customer; (iii) receive customer
15 payment instructions from the customer in
response to the request for payment
instructions; and (iv) transmit the
customer payment instructions from the
customer directly to said invoicer, said
20 payment instructions including at least a
customer invoice account number and an
associated customer payment account; and
(c) a payment source, said invoice presentment
electronics adapted to transmit the
25 payment instructions to the payment source
after customer review.

51. The system according to Claim 50, wherein said
payment source is a clearing house.
30

52. The system according to Claim 51, wherein said
clearing house is a courier.

53. The system according to Claim 51, wherein said
clearing house is a payment network.
35

54. The system according to Claim 50, wherein said
payment instructions include transmission date.

55. The system according to Claim 50, wherein said payment instructions include amount to draft from customer associated financial institution.

5

56. The system according to Claim 50, wherein said payment instructions include account information associated with the customer from which to draft payment.

10

57. The system according to Claim 50, wherein said payment instructions include account information associated with the invoicer from which to deposit payment.

15

58. The system according to Claim 50, wherein said billing data includes invoicer billing information.

59. The system according to Claim 58, wherein said billing information includes a due date.

20

60. The system according to Claim 58, wherein said billing information includes an amount due.

61. The system according to Claim 58, wherein said billing information includes a list of goods or services provided during a billing period.

25

62. The system according to Claim 58, wherein said billing information includes a late charge.

30

63. The system according to Claim 58, wherein said billing information includes account information.

64. The system according to Claim 50, wherein said billing data includes customer information.

35

65. The system according to Claim 64, wherein said

customer information includes customer name.

66. The system according to Claim 64, wherein said customer information includes customer address.

5

67. The system according to Claim 64, wherein said customer information includes account information for the customer.

10

68. The system according to Claim 50, wherein said billing data includes a customer account identifier.

69. The system according to Claim 50, wherein said billing data includes an invoice identifier.

15

70. The system according to Claim 50, wherein said invoice presentment electronics includes invoice information relating to customer bills and account information relating to financial institutions associated with the customer from which payments may be drafted.

20

71. The system according to Claim 70, wherein said invoice presentment electronics further includes preauthorized payment instructions for automated payment of a billing amount set out in said billing information from an account set out in said account information.

25

72. The system according to Claim 71, wherein the request for payment instructions from said invoice presentment electronics query the customer if the preauthorized payment instructions are desired for the billing data presented.

30

73. The system according to Claim 71, wherein the request for payment instructions from said invoice presentment electronics query the customer if the preauthorized payment instructions need modification for

35

the billing data presented.

74. The system according to Claim 71, wherein said customer authorization interface includes an editor for
5 modifying the preauthorized payment instructions.

75. The system according to Claim 70, wherein the account information includes account information from a plurality of financial institutions and the request for
10 payment instructions query the customer to select the financial institution from which to draft payment for an associated customer bill.

76. The system according to Claim 75, wherein said invoice presentment electronics includes a preauthorized
15 default identifying the financial institution from which to draft payment for said associated customer bill.

77. The system according to Claim 76, wherein said electronic customer authorization interface is adapted to
20 receive a customer input to accept the preauthorized default.

78. The system according to Claim 76, wherein said electronic customer authorization interface is adapted to
25 receive a customer input to modify the preauthorized default.

79. The system according to Claim 50, wherein said request for payment instructions include billing
30 information selected from the group consisting of amount due, time of payment, account from which to draft payment.

80. The system according to Claim 79, wherein said customer authorization interface is adapted to modify the
35 billing information to change one or more of the group

consisting of amount due, time of payment and account
from which to draft payment.

5 81. The system according to Claim 50, wherein said
billing data include notices for the customer.

10 82. The system according to Claim 50, wherein said
billing data include advertising information directed
towards the customer.

83. The system according to Claim 50, wherein said
billing data include control information.

15 84. The system according to Claim 50, wherein said
payment instructions include a date to draft payment.

85. The system according to Claim 50, wherein said
payment instructions include a amount of invoice.

20 86. The system according to Claim 50, wherein said
invoicer provides a customer accessible site for
receiving said billing data and said request for payment
instructions, said site accessible from said electronic
customer authorization interface.

25 87. The system according to Claim 86, wherein said
customer accessible site is an Internet site and said
electronic customer authorization interface includes a
browser for accessing said customer accessible site.

30 88. The system according to Claim 86, wherein said
electronic customer authorization interface is an
automated teller machine.

35 89. The system according to Claim 86, wherein said
electronic customer authorization interface is a remote
kiosk.

90. The system according to Claim 86, wherein said electronic customer authorization interface is a personal computer.

5 91. The system according to Claim 86, wherein said electronic customer authorization interface is an interactive television.

10 92. The system according to Claim 86, wherein said electronic customer authorization interface is a telephone.

15 93. The system according to Claim 86, wherein said electronic customer authorization interface is a computer, said billing data and said request for payment instructions are presented by e-mail to the customer and the customer payment instructions are provided by a customer e-mail.

20 94. The system according to Claim 86, wherein said electronic customer authorization interface includes a display for presenting said billing data and said request for payment instructions and a customer actuatable input for receiving customer payment instructions.

25 95. The system according to Claim 86, wherein said electronic customer authorization interface includes audio electronics and a speaker for presenting said billing data and said request for payment instructions and a customer actuatable input for receiving customer payment instructions.

30 96. The system according to Claim 86, wherein said electronic customer authorization interface is adapted to allow a customer to poll said invoice presentment electronics to receive said billing data and said request

for payment instructions.

5 97. A computerized method for automated electronic invoicing and payment system for providing remote customer review of automated billing from an invoicer, said method comprising the steps of:

- 10 (a) presenting customer billing data for customer review and requesting payment instructions relating to automated billing to said customer using an invoice presentation electronics; and
- 15 (b) receiving the customer billing data for customer review and the request for payment instructions from said invoice presentation electronics to said customer using a remote electronic customer authorization interface; and
- 20 (c) providing customer payment instructions from the customer in response to the request for payment instructions directly to said invoicer, said payment instructions including at least a customer invoice account number and an associated customer payment account.

25

98. A computerized method for automated electronic invoicing and payment system for providing remote customer review of automated billing from an invoicer using a remote electronic customer authorization interface, said method comprising the steps of:

- 30 (a) receiving customer billing data for customer review and a request for payment instructions from said invoicer;
- 35 (b) receiving customer payment instructions from the customer in response to said request for payment instructions from said invoicer; and

5 (c) transmitting the customer payment instructions from the customer directly to said invoicer, said payment instructions including at least a customer invoice account number and an associated customer payment account.

10 99. A computerized method for automated electronic invoicing and payment system for providing remote customer review of automated billing from an invoicer, said method comprising the steps of:

- 15 (a) presenting customer billing data for customer review and requesting payment instructions relating to automated billing to said customer using an invoice presentation electronics;
- 20 (b) authorizing payment using a remote electronic customer authorization interface, said customer interface including: means for receiving customer billing data for customer review and a request for payment instructions from said invoicer; means for receiving customer payment instructions from the customer in response to said request for payment
- 25 instructions from said invoicer; and means for transmitting the customer payment instructions from the customer to said invoicer, said interface adapted to: (i) receive the customer billing data for customer review and the request for payment instructions from said invoice presentation electronics; (ii) provide the customer billing data for customer review
- 30 and the request for payment instructions to the customer; (iii) receive customer payment instructions from the customer in response to the request for payment
- 35

PCT/US 98/17154
IPEA/US 25 OCT 1999

5 instructions; and (iv) transmit the
customer payment instructions from the
customer directly to said invoicer, said
payment instructions including at least a
customer invoice account number and an
associated customer payment account; and
(c) transmitting the payment instructions to a
payment source after customer review using
said invoice presentment electronics.

10

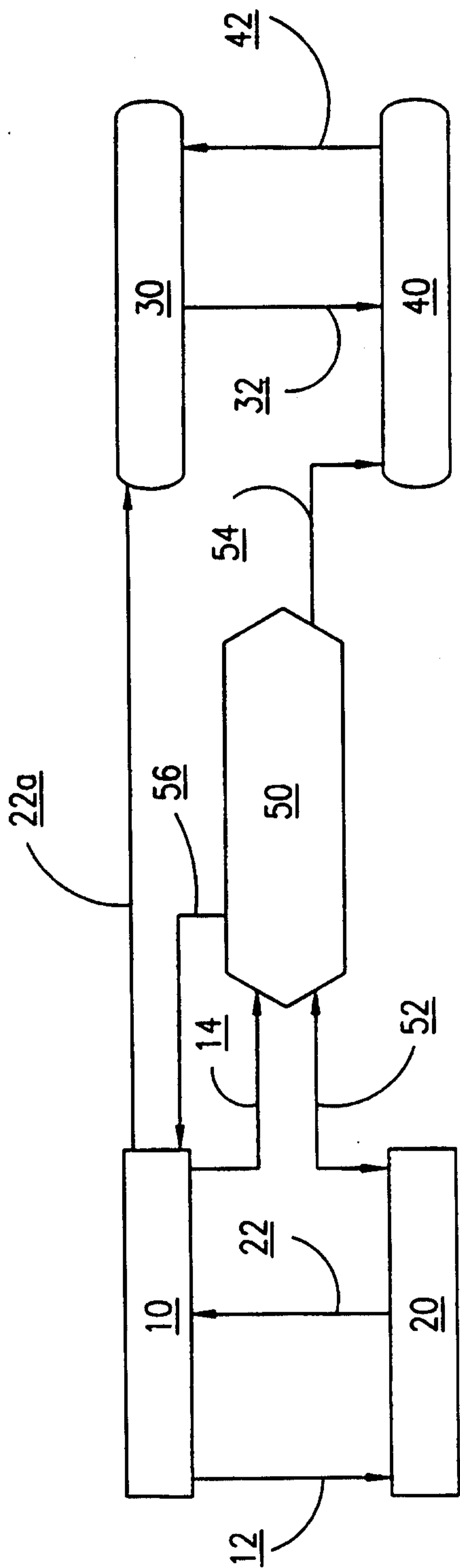

FIG. 1

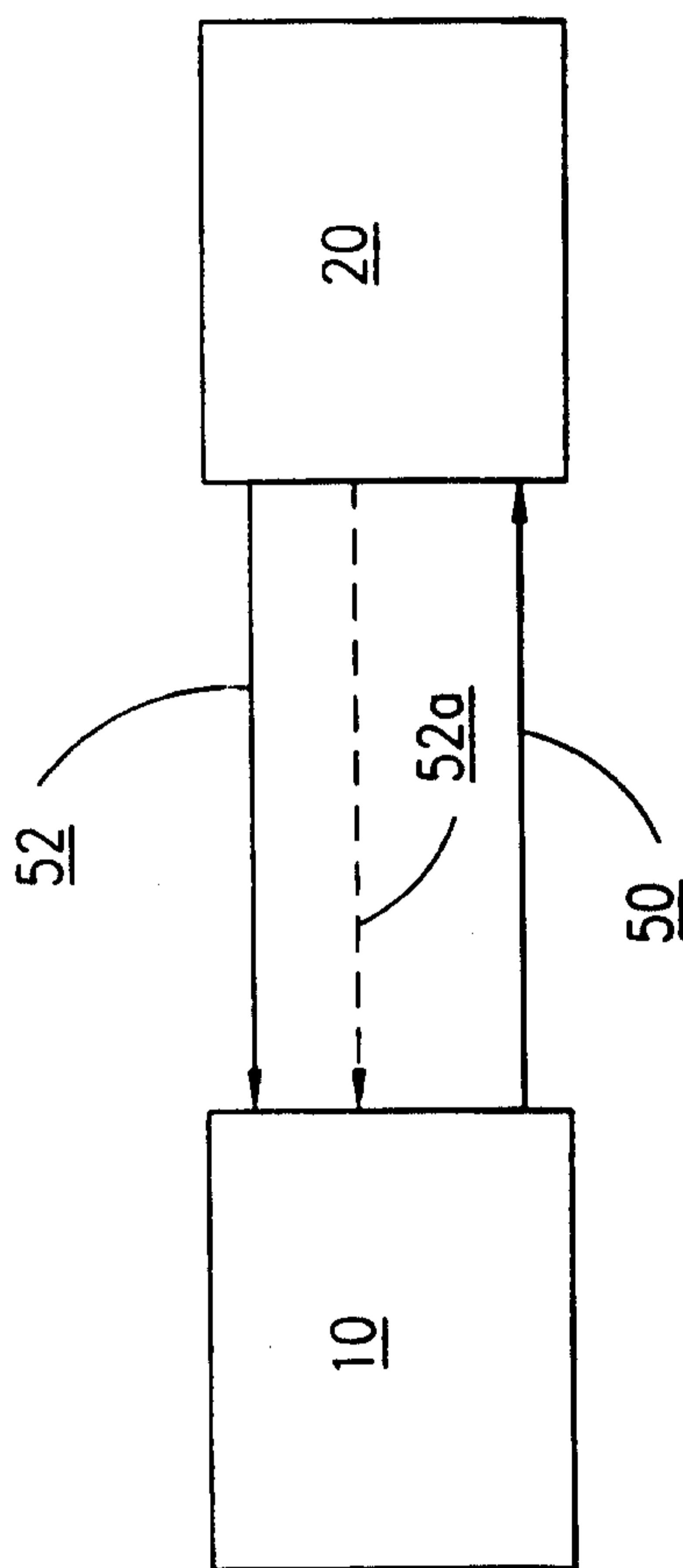

FIG. 2

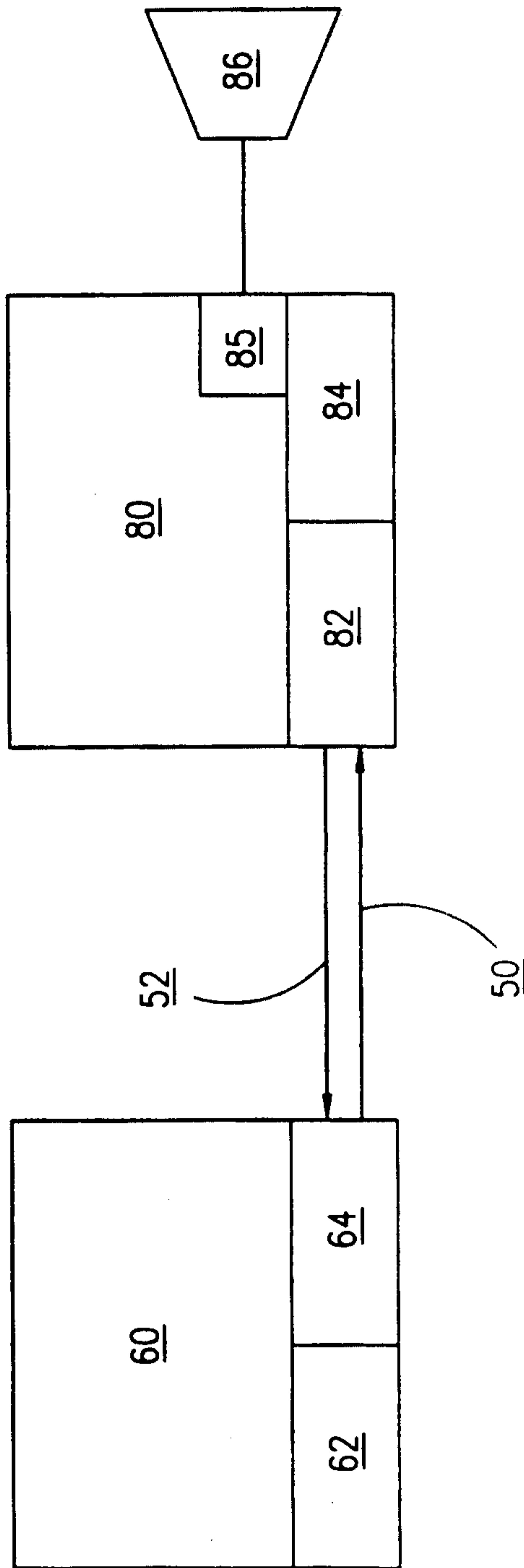

FIG. 3A

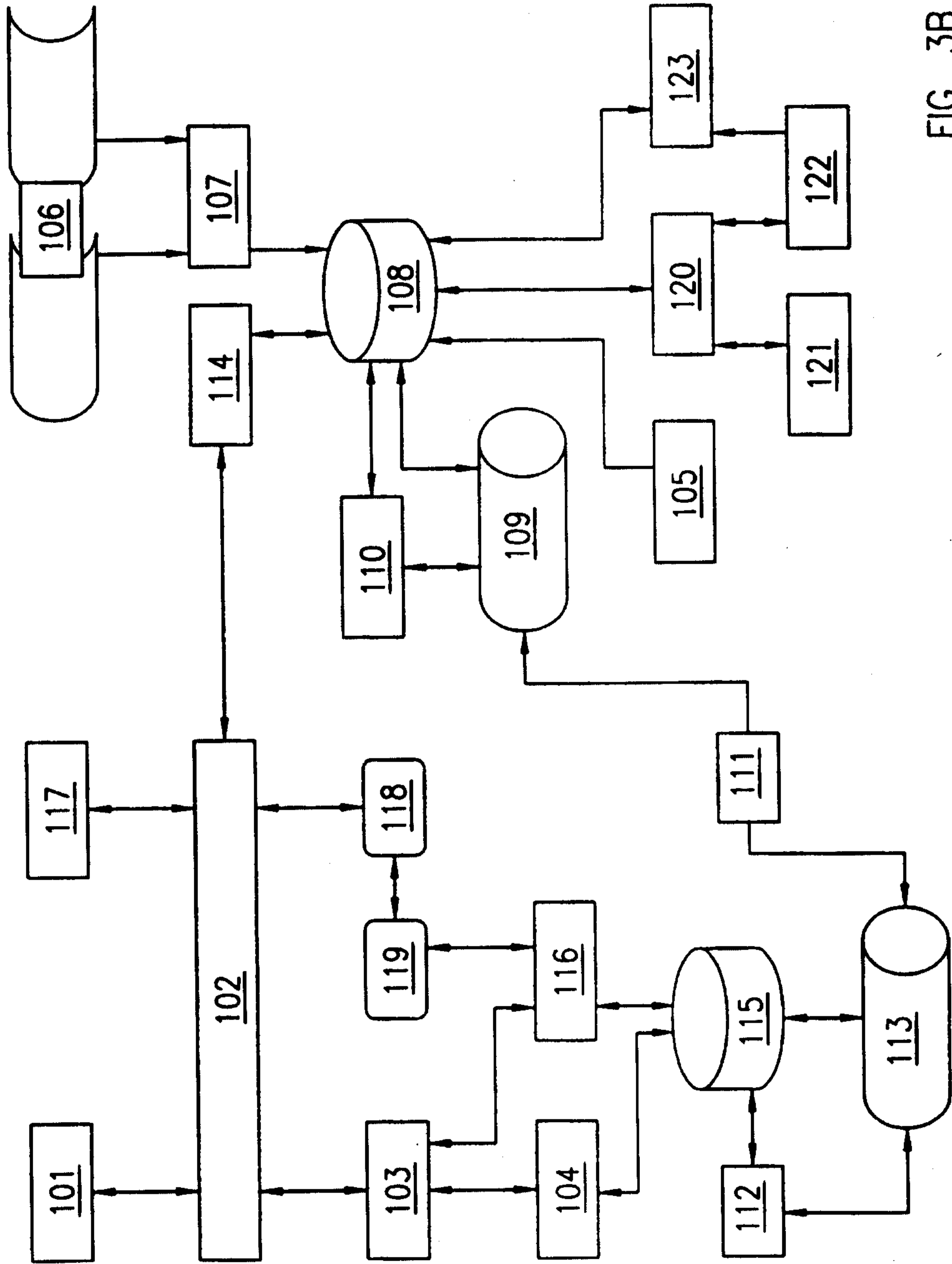

FIG. 3B