

INTERNATIONAL APPLICATION PUBLISHED UNDER THE PATENT COOPERATION TREATY (PCT)

<p>(51) International Patent Classification ⁶ : H02J 7/00, H01M 10/48</p>	<p>A1</p>	<p>(11) International Publication Number: WO 99/22433</p> <p>(43) International Publication Date: 6 May 1999 (06.05.99)</p>
<p>(21) International Application Number: PCT/SE98/01942</p> <p>(22) International Filing Date: 27 October 1998 (27.10.98)</p> <p>(30) Priority Data: 9703931-7 28 October 1997 (28.10.97) SE</p> <p>(71) Applicant: TELEFONAKTIEBOLAGET LM ERICSSON (publ) [SE/SE]; S-126 25 Stockholm (SE).</p> <p>(72) Inventor: OLSSON, Jan, Evert, Torbjörn; Syrénstigen 8, S-247 32 Södra Sandby (SE).</p> <p>(74) Agent: ERICSSON MOBILE COMMUNICATIONS; IPR Dept., S-221 83 LUND (SE).</p>	<p>(81) Designated States: AL, AM, AT, AU, AZ, BA, BB, BG, BR, BY, CA, CH, CN, CU, CZ, DE, DK, EE, ES, FI, GB, GD, GE, GH, GM, HR, HU, ID, IL, IS, JP, KE, KG, KP, KR, KZ, LC, LK, LR, LS, LT, LU, LV, MD, MG, MK, MN, MW, MX, NO, NZ, PL, PT, RO, RU, SD, SE, SG, SI, SK, SL, TJ, TM, TR, TT, UA, UG, UZ, VN, YU, ZW, ARIPO patent (GH, GM, KE, LS, MW, SD, SZ, UG, ZW), Eurasian patent (AM, AZ, BY, KG, KZ, MD, RU, TJ, TM), European patent (AT, BE, CH, CY, DE, DK, ES, FI, FR, GB, GR, IE, IT, LU, MC, NL, PT, SE), OAPI patent (BF, BJ, CF, CG, CI, CM, GA, GN, GW, ML, MR, NE, SN, TD, TG).</p> <p>Published With international search report.</p>	

(54) Title: AN IDENTIFICATION ARRANGEMENT AND METHOD

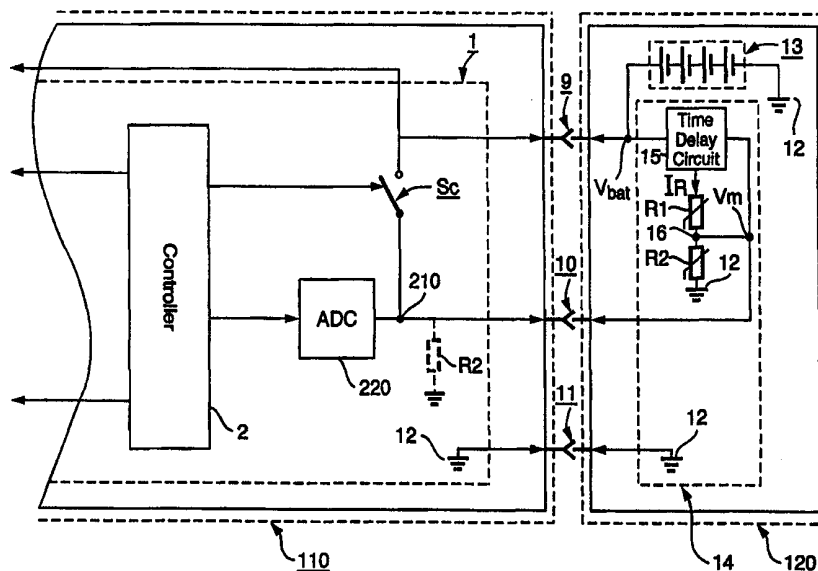

(57) Abstract

The invention provides a battery identification arrangement, a battery equipment (120) suitable for identification and a battery identification method for implementation in an electronic equipment (110) such as a mobile station or a charger with a battery (13). The present invention also relates to a method to measure the temperature of a battery (13) connected to an electronic equipment (110). The battery identification arrangement includes both a measurement circuit (1) of the electronic equipment (110) and a battery circuit (14) of a battery equipment (120). On identifying, means in the measurement circuit (1) measure at least one identification voltage (V_{id}) which is generated by dividing a battery voltage (V_{bat}) into a division ratio by means of in series connected resistors (R_1 , R_2) connected to ground (12). The resistors (R_1 , R_2) are connected to the battery (13) only during measurement of the identification voltage (V_{id}) and the battery voltage (V_{bat}).

FOR THE PURPOSES OF INFORMATION ONLY

Codes used to identify States party to the PCT on the front pages of pamphlets publishing international applications under the PCT.

AL	Albania	ES	Spain	LS	Lesotho	SI	Slovenia
AM	Armenia	FI	Finland	LT	Lithuania	SK	Slovakia
AT	Austria	FR	France	LU	Luxembourg	SN	Senegal
AU	Australia	GA	Gabon	LV	Latvia	SZ	Swaziland
AZ	Azerbaijan	GB	United Kingdom	MC	Monaco	TD	Chad
BA	Bosnia and Herzegovina	GE	Georgia	MD	Republic of Moldova	TG	Togo
BB	Barbados	GH	Ghana	MG	Madagascar	TJ	Tajikistan
BE	Belgium	GN	Guinea	MK	The former Yugoslav Republic of Macedonia	TM	Turkmenistan
BF	Burkina Faso	GR	Greece			TR	Turkey
BG	Bulgaria	HU	Hungary	ML	Mali	TT	Trinidad and Tobago
BJ	Benin	IE	Ireland	MN	Mongolia	UA	Ukraine
BR	Brazil	IL	Israel	MR	Mauritania	UG	Uganda
BY	Belarus	IS	Iceland	MW	Malawi	US	United States of America
CA	Canada	IT	Italy	MX	Mexico	UZ	Uzbekistan
CF	Central African Republic	JP	Japan	NE	Niger	VN	Viet Nam
CG	Congo	KE	Kenya	NL	Netherlands	YU	Yugoslavia
CH	Switzerland	KG	Kyrgyzstan	NO	Norway	ZW	Zimbabwe
CI	Côte d'Ivoire	KP	Democratic People's Republic of Korea	NZ	New Zealand		
CM	Cameroon			PL	Poland		
CN	China	KR	Republic of Korea	PT	Portugal		
CU	Cuba	KZ	Kazakstan	RO	Romania		
CZ	Czech Republic	LC	Saint Lucia	RU	Russian Federation		
DE	Germany	LI	Liechtenstein	SD	Sudan		
DK	Denmark	LK	Sri Lanka	SE	Sweden		
EE	Estonia	LR	Liberia	SG	Singapore		

AN IDENTIFICATION ARRANGEMENT AND METHOD**TECHNICAL FIELD OF THE INVENTION**

5 The present invention relates to a battery identification arrangement of an electronic equipment with a battery and a battery equipment suitable for identification. The present invention also relates to a battery identification method for implementation in an electronic equipment with a
10 battery. The present invention also relates to a method to measure the temperature of a battery connected to an electronic equipment.

DESCRIPTION OF RELATED ART

15

Some portable radio communication equipments use a detachable rechargeable battery as a power supply.

20 A portable radio communication equipment, which herein after is referred to as a mobile station, includes all portable radio communication equipment such as mobile stations, pagers, communicators, so called electronic organizers, or the like.

25 Numerous different types of detachable battery types are available in view of the portability and power supply efficiency of the mobile station. A standard battery, i.e. a battery with a standard capacity, is used for standard use and a battery which has a large capacity is used for
30 prolonged high power use. The batteries can be of different types such as nickel-cadmium batteries, nickel metal hydride batteries, alkaline batteries, manganese batteries or lithium-ion batteries. Each battery has different battery parameters such as voltage or current capacities, number of
35 cells and temperature. It is necessary to know some of these

parameters in order to verify that a battery which is attached to a mobile station is of the correct type. Otherwise the battery might for instance leak chemical substances or output the wrong voltage or be charged in a wrong way.

A mobile station which uses a battery may have a function of automatically discriminating the battery connected to the mobile station if the battery does not match the mobile station. Also chargers for rechargeable batteries may have this function.

Different types of battery keying methods used for determining which type of battery that is connected to the electronic equipment are known such as mechanical keying, magnetic keying, optical keying and electrical keying. Electrical keying can be realised by means of a key resistor in the battery. Other known methods for determining which type of battery that is connected to the electronic equipment are to include a memory or a number of diodes in the battery.

U.S. 5,200,686 describes a method and an apparatus for distinguishing between different types of batteries that are connected to a battery power equipment. In U.S. 5,200,686 determination of battery type is accomplished by measuring the value of a resistance of a resistor internal to the battery. According to an embodiment of U.S. 5,200,686 the resistor with the resistance that is to be measured is placed in a voltage divider network to which a known voltage is applied. The voltage divider network is placed internal to the battery and comprises one or more known resistances besides the resistor with the resistance that is to be measured. One disadvantage with the method and apparatus described in U.S. 5,200,686 is that the absolute tolerance of the resistor with the resistance that is to be measured

is limiting the number of different types of batteries which it is possible to distinguish.

U.S. 5,489,834 describes a circuit for determining the
5 temperature and type of battery selected from a plurality of
battery types. The temperature is detected by measuring the
voltage drop across a temperature dependant first resistor
in the battery. The measured voltage is scaled to different
levels by a second resistor in order to determine the type
10 of battery. One disadvantage with the circuit described in
U.S. 5,489,834 is that the absolute tolerance of the first
and second resistor is limiting the number of different
types of batteries which it is possible to distinguish.

15 EP 642,202 describes an electronic device and a battery. The
electronic device switches its operation mode in accordance
with the type of installed battery. The battery has a
regulator, a specification-discriminating terminal, and a
resistor, connected between the regulator and the
20 specification-discriminating terminal. The resistor has a
resistance corresponding to the specification of the
incorporated battery. The electronic device has a monitor
resistor connected between a terminal connected to the
specification-discriminating terminal of the battery and
25 ground, a discriminating circuit for detecting a monitor
voltage generated across this monitor resistor to
discriminate the specification of the battery, and a switch
controller for switching the operation mode in accordance
with the specification discriminated by the discriminating
30 circuit.

One disadvantage with the technique described in EP 642,202
is that both the resistor connected between the regulator
and the specification-discriminating terminal and the
35 monitor resistor connected between the terminal connected to
the specification-discriminating terminal of the battery and

ground, consume power also when the determination of type of battery already has been made.

U.S. 5,237,257 and U.S. 5,164,652 describe a method and an
5 apparatus to detect the type of battery connected to a
circuit of a battery operated equipment. A first resistor is
disposed within the battery operated equipment. A second
resistor having a resistance selected in accordance with the
particular battery is disposed within the battery. A battery
10 type detector measures a sense input signal which is
generated from a regulated voltage reduced in proportion to
the ratio of the first resistor and the second resistor. One
disadvantage with the method and apparatus described in U.S.
5,237,257 and U.S. 5,164,652 is that the resistors internal
15 to the battery and the battery operated equipment that are
used for determination of the battery type consume power
also when the determination of battery type already has been
made. Yet another disadvantage with the method and apparatus
described in U.S. 5,237,257 and U.S. 5,164,652 is that the
20 absolute tolerance of the first and second resistor is
limiting the number of different types of batteries which it
is possible to distinguish.

SUMMARY OF THE INVENTION

25
The general problem dealt with by the present invention is
to provide a battery equipment suitable for identification
and a battery identification arrangement. The problem also
includes a method for implementation in an electronic
30 equipment with a battery. The term battery herein after
refers to the battery cells of a unit, and the unit
comprising those battery cells herein after is referred to
as a battery equipment. The electronic equipment can be a
charger or any kind of portable radio communication
35 equipment such as mobile stations, pagers, communicators, so
called electronic organizers, or the like.

A more specific problem dealt with by the present invention is to provide a battery identification arrangement and a method for implementation in an electronic equipment with a battery which distinguishes many different types of batteries that are coupled to an electronic equipment from each other and which consumes no power in stand-by mode.

A further more specific problem dealt with by the present invention is to measure the temperature of a battery connected to an electronic equipment.

The problem is solved essentially by a battery equipment and also by a battery identification arrangement in which at least one identification voltage is generated by dividing a battery voltage into a division ratio by means of in series connected resistors connected to ground. The resistors are connected to the battery only during the measurement of the identification voltage and the battery voltage.

More specifically, the battery identification arrangement includes both a measurement circuit of the electronic equipment and a battery circuit of the battery equipment. Means in the measurement circuit measure the identification voltage and the battery voltage. The value of the identification voltage distinguishes different batteries from each other. A controller of the measurement circuit controls a control switch of the measurement circuit and a time delay switch of a time delay circuit of the battery circuit. During measurement, first both the control switch and the time delay switch are closed when the battery voltage is measured. Secondly, the control switch is opened and the time delay switch is closed when the identification voltage is measured. When the measurement has been made, both the control switch and the time delay switch are opened, which prevents that the battery identification

arrangement consumes power when the determination of the type of battery has been made, i.e. in stand-by mode.

The invention makes it also possible to measure the
5 temperature of the battery. The in series connected resistors can be selected to have well defined temperature coefficients and a current generator is generating a predetermined current through one of the in series connected resistors. The voltage over one of the in series connected
10 resistors to ground is measured.

More precisely, the present invention also relates to a battery identification method for implementation in an electronic equipment with a battery. The battery
15 identification method is used for determining which type of battery that is connected to the electronic equipment.

A general object of the present invention is to provide a battery equipment suitable for identification and a battery
20 identification arrangement. The object is also to provide a method for implementation in an electronic equipment with a battery for determination of which type of battery that is connected to the electronic equipment.

25 It is another object of the present invention to select and modify parameters of the battery equipment and the battery identification arrangement according to the type of battery that is to be identified. These parameters are the values of the resistances of the in series connected resistors.
30

A further object of the present invention is to provide a battery identification arrangement and a method for
35 implementation in an electronic equipment that consumes no power in stand-by mode.

A further object of the present invention is to distinguish many different types of batteries, that are coupled to an electronic equipment, from each other.

5 A further object of the present invention is to measure the temperature of a battery connected to an electronic equipment.

10 A further object of the present invention is to provide a battery identification arrangement and a method for implementation in an electronic equipment that is temperature stable.

15 A general advantage afforded by the present invention is that a safe battery identification arrangement and a method for implementation in an electronic equipment with a battery are provided.

20 A more specific advantage afforded by the present invention is that a method and an arrangement that consumes no power when the determination of the type of battery already has been made, i.e. in stand-by mode, are provided.

25 A more specific advantage afforded by the present invention is that a method and an arrangement which distinguishes many different types of batteries that are coupled to an electronic equipment from each other are provided. This is easily obtained by matching the in series connected resistors to each other.

30

Another more specific advantage afforded by the present invention is that many different types of batteries can be identified since parameters of the battery identification arrangement can be selected and modified according to the
35 type of battery which is to be identified.

Another more specific advantage afforded by the present invention is that it is possible to measure the temperature of the battery.

5 Another more specific advantage afforded by the present invention is that the battery identification method is temperature stable. This is because the identification voltage which is generated by dividing the battery voltage into a division ratio does not change with temperature.

10

Yet another more specific advantage afforded by the present invention is that the implementation of the hardware of the controller is simple.

15 The invention will now be described more in detail below with reference to the appended drawings which illustrate various aspects of the invention by means of embodiments. The invention is not limited to these embodiments.

20

BRIEF DESCRIPTION OF THE DRAWINGS

Figure 1 is a schematic view of blocks in a mobile station and a battery equipment;

25

Figure 2 illustrates a block scheme of an inventive arrangement with a battery circuit;

30

Figure 3 is a schematic view of a time delay circuit of the battery circuit;

Figure 4 illustrates in a scheme an embodiment of the time delay circuit of the battery circuit;

35

Figure 5 illustrates in a scheme an embodiment of the time delay circuit of the battery circuit;

Figure 6 illustrates in a scheme an embodiment of a measurement circuit of the mobile station;

5 Figure 7a illustrates in a time diagram the status open/closed of a switch in the measurement circuit;

Figure 7b illustrates in a time diagram the status open/closed of a switch in the time delay circuit;

10

Figure 7c illustrates in a time diagram the potential at a measurement and control connection between the measurement circuit and the battery circuit according to an embodiment of the present invention;

15

Figure 7d illustrates in a time diagram the potential at a measurement and control connection between the measurement circuit and the battery circuit according to an embodiment of the present invention;

20

Figure 7e illustrates in a time diagram the total current consumption of the measurement circuit and the battery circuit;

25 Figure 8 illustrates examples of how the division ratio between the resistance of different in series connected resistors R1, R2 of the battery circuit can vary in different embodiments of the present invention;

30 Figure 9 illustrates in a scheme an embodiment of the battery circuit of the present invention;

Figure 10 illustrates in a scheme an embodiment of the battery circuit of the present invention;

35

Figure 11a illustrates in a flowchart a method for identifying a predetermined type of battery;

Figure 11b illustrates in a flowchart a method for measuring the temperature of the battery circuit of the present invention.

DETAILED DESCRIPTION OF EMBODIMENTS

Figure 1 illustrates a block view of an electronic equipment 110 and a battery equipment 120.

The electronic equipment 110 is a mobile station that comprises a measurement circuit 1 which comprises a controller 2. The controller 2 controls a transceiver 3, a baseband modulator/demodulator 4 and a driver/amplifier 5 of the mobile station 110. The transceiver 3 is coupled to an antenna 6 of the mobile station 110. The driver/amplifier 5 is coupled to a microphone 8 and a speaker 7 of the mobile station 110. The transceiver 3 and the baseband modulator/demodulator 4 are coupled to each other and also the baseband modulator/demodulator 4 and the driver/amplifier 5 are coupled to each other. The measurement circuit 1 is connected to a battery voltage connection 9, to a measurement and control connection 10 and to a ground connection 11 which is connected to ground 12. Hence, the measurement circuit 1 is connected to ground 12.

The battery equipment 120 comprises a battery 13 and a battery circuit 14. The battery 13 is connected to ground 12 and to the battery voltage connection 9. The battery circuit 14 is connected to the battery voltage connection 9, to the measurement and control connection 10 and to the ground connection 11. Hence, the battery circuit is connected to ground 12.

The mobile station 110 and the battery equipment 120 are connected to each other at the battery voltage connection 9, at the measurement and control connection 10 and at the ground connection 11 when connecting the mobile station to the battery equipment.

Figure 2 illustrates a block view of a battery identification arrangement of the present invention illustrated in Figure 1.

10

The battery identification arrangement comprises the measurement circuit 1, the battery circuit 14 and the battery 13 which all are connected to ground 12. The measurement circuit 1 is comprised in the electronic equipment which is the mobile station 110.

15

The measurement circuit 1 comprises a controller 2. The controller 2 controls those functions of the mobile station 110 which are not comprised in the measurement circuit 1 (see Figure 1). The controller 2 also controls an analogue-to-digital converter 220 and a control switch S_c of the measurement circuit 1. The measurement circuit 1 is connected to the battery voltage connection 9, to the measurement and control connection 10 and to the ground connection 11 which is connected to ground 12. The measurement circuit 1 is also connected to functions of the mobile station 110 which are not comprised in the measurement circuit 1. The control switch S_c , which is controlled by the controller 2, is connected between the battery voltage connection 9 and the measurement and control connection 10.

20

25

30

There is a dividing connection 210 between the control switch S_c and the measurement and control connection 10. The analogue-to-digital converter 220, which also is controlled by the controller 2, is connected to the dividing connection

35

210 between the control switch Sc and the measurement and control connection 10.

The battery circuit 14 comprises a time delay circuit 15 and
5 a first and a second in series connected resistors R1, R2.
The first resistor R1 of the in series connected resistors
is connected to the time delay circuit 15. The second
resistor R2 is connected to ground 12. There is a dividing
10 connection 16 between the in series connected resistors R1,
R2 at which there is a potential which is a measurement
voltage Vm. The time delay circuit 15 is connected to the
battery voltage connection 9, to the measurement and control
connection 10 and to the dividing connection 16 between the
in series connected resistors R1, R2.

15
In a preferred embodiment of the present invention, the two
in series connected resistors R1, R2 have common well
defined temperature coefficients, i.e. the resistance of the
resistors R1, R2 vary equally with the temperature. This
20 embodiment of the present invention is further described in
Figure 6.

The battery 13 has poles which are connected between the
battery voltage connection 9 and ground 12, respectively.
25 There is a potential at the battery voltage connection 9
which is the battery voltage Vbat.

The mobile station 110 and the battery equipment 120, and
hence the measurement circuit 1 and the battery circuit 14,
30 are connected to each other at the battery voltage
connection 9, at the measurement and control connection 10
and at the ground connection 11 when connecting the battery
equipment to the mobile station.

35 The battery identification arrangement is used for
determining which type of battery 13 that is connected to the

mobile station 110. During measurement, the mobile station 110 and the battery equipment 120 are connected to each other wherein the controller 2 controls the control switch Sc, the time delay circuit 15 and the analogue-to-digital converter 220.

The analogue-to-digital converter 220 measure battery circuit characteristics which are the battery voltage Vbat and a battery identification voltage Vid (see Figures 7a-7d). Both the battery voltage Vbat and the battery identification voltage Vid are measured at the measurement and control connection 10. The value of the identification voltage Vid distinguishes different batteries from each other which is further described in Figure 8.

It shall be noted that the inventive arrangement requires only the three connections 9, 10, 11 between the mobile station and the battery equipment. This is of importance since such connections are of high quality and rather expensive.

The operation of the battery identification arrangement will here be described in an embodiment as shown in Figure 3. This Figure is a schematic view of a time delay circuit of the present invention illustrated in Figure 2. The time delay circuit 15 comprises a time delay switch St and a time delay controller 310. The time delay switch St is connected between the battery voltage connection 9 shown in dashed lines (compare Figure 2) and the resistor R1 shown in dashed lines (compare Figure 2). The time delay controller 310 which controls the time delay switch St is connected to the measurement and control connection 10 shown in dashed lines (compare Figure 2). There is a control input 320 of the time delay switch St. The control input 320 is connected to the time delay controller 310. The time delay controller 310 is controlled via a signal transmitted from the measurement and

control connection 10 (see Figure 2). The time delay switch St can be of different types of switches such as a mechanical switch or a transistor.

5 The controller 2 of the measurement circuit 1 initiates measurement of the identification voltage V_{id} and the battery voltage V_{bat} wherein the control switch Sc and the time delay switch St are closed when the battery voltage V_{bat} is measured by the analogue-to-digital converter ADC.
10 Secondly, the control switch Sc is opened and the time delay switch St is closed when the identification voltage V_{id} is measured by the analogue-to-digital converter ADC. When the measurement has been made, both the control switch and the time delay switch are open, which prevents that the battery
15 identification arrangement consumes power when the determination of the type of battery 13 has been made, .i.e. in stand-by mode.

The time delay switch St is closed when the identification
20 voltage V_{id} , which can not be generated by the battery circuit 14, is above a certain level (see Figure 8). The time delay controller 310 holds the voltage at the dividing connection 16 between the in series connected resistors $R1$, $R2$ at the level of the battery identification voltage V_{id}
25 until the analogue-to-digital converter has finished the voltage detection. Hereby the time delay switch St prevents that the battery identification arrangement consumes power in stand-by-mode. The battery identification voltage V_{id} is generated by dividing the battery voltage V_{id} into a
30 division ratio by means of the in series connected resistors $R1$, $R2$ connected to ground 12. The resistors $R1$, $R2$ are connected to the battery 13 only during the measurement of the identification voltage V_{id} and the battery voltage V_{bat} . A current I_r passes the resistor $R1$ during the
35 identification.

It shall be mentioned that in an alternative embodiment of the present invention the resistor R2 of the in series connected resistors R1, R2 that is connected to ground 12 is arranged in the measurement circuit 1 instead of in the battery circuit 14. This is shown in dashed lines in Figure 2. In this embodiment, the resistors R1, R2 are connected in series when the mobile station 110 and the battery equipment 120 are connected to each other.

It shall also be mentioned that the present invention can be accomplished without any time delay circuit 15. In this embodiment the battery voltage V_{bat} and the identification voltage V_{id} are measured without switching on and off any time delay switch (see Figures 7a-7e). However, in this embodiment the total current consumption I_C of the measurement circuit will not be zero after the time period T_{St} (see Figure 7e).

Figure 4 illustrates in a scheme an embodiment of the time delay circuit of the present invention illustrated in Figure 3. The time delay circuit comprises the time delay switch and the time delay controller.

The time delay switch S_t consists of a CMOS-transistor 410 having a gate G, a drain D and a source S. The gate G is connected to the time delay controller 310, the drain D is connected to the resistor R1 shown in dashed lines (compare Figure 2) and the source S is connected to the battery voltage connection 9 shown in dashed lines (compare Figure 2).

The time delay controller 310 consists of a capacitor 19, a resistor 20, an inverter 420 and a diode 21 having a cathode 22 and an anode 23. The inverter 420 is connected between the measurement and control connection 10 and the cathode 22. The anode 23 is connected to the gate G of the CMOS-

transistor 410. The capacitor 19 and the resistor 20 are each connected between the anode 23 and the battery voltage connection 9. The time delay controller 310 is controlled via a signal transmitted from the measurement and control
5 connection 10.

The operation of the battery identification arrangement in Figure 4 is in accordance with the operation of the battery identification arrangement described in Figure 3.
10

The time delay switch St can be of different types of switches such as a mechanical switch or a transistor. The time delay switch St is connected between the battery voltage connection 9 shown in dashed lines and the resistor R1 shown in dashed lines (compare Figure 2). The time delay
15 switch St is controlled via a signal transmitted from the measurement and control connection 10 (see Figure 2), i.e. there is a control input which in Figure 4 is the gate G of the time delay switch St. The control input is connected to
20 the measurement and control connection 10 shown in dashed lines (compare Figure 2).

Figure 5 illustrates in a scheme an embodiment of the time delay circuit 15 of the present invention illustrated in
25 Figure 3.

The time delay controller 310 consists of a capacitor 24 which is connected in parallel with the time delay switch St.
30

There is a control input 320 of the time delay switch St. The control input 320 is connected to the measurement and control connection 10 shown in dashed lines (compare Figure
2).
35

The operation of the battery identification arrangement in Figure 5 is in accordance with the operation of the battery identification arrangement described in Figure 2.

5 Figure 6 illustrates in a scheme an embodiment of the measurement circuit 1 of the present invention. The embodiment is identical with the embodiment of the present invention illustrated in Figure 2, except of that the measurement circuit 1 in Figure 6 also comprises a
10 current generator 25 and that the in series connected resistors R1, R2 shall have a common well defined temperature coefficients, i.e. the resistance of the resistors R1, R2 shall vary equally with the temperature. The current generator 25, which is controlled via the
15 controller 2, is connected between the battery voltage connection 9 and the measurement and control connection 10.

The current generator 25 is arranged for delivering a predetermined current I through the in series connected
20 resistor R2 (see Figure 2) for measuring the temperature of the battery circuit 14. The temperature of the battery circuit 14 is measured by measuring the measurement voltage V_m without switching on any of the control switch S_c or time delay switch S_t . Consequently, since the measurement voltage
25 V_m is measured, the current $I_R=I$ (see Figure 2) is known and the temperature coefficients of the in series connected resistors R1, R2 are known it is then possible to calculate the temperature of the battery circuit 14. The temperature of the battery circuit 14 is in practice the same as the
30 temperature of the battery 13.

Figures 7a-7e show time diagrams of the function of the described battery identification arrangement. Time is denoted by t in the diagrams. In those Figures, the values
35 of the identification voltage V_{id} and the battery voltage

Vbat are the values of the measurement voltage V_m during a time period T_{Sc} and a time period T_{Vid} , respectively.

Figure 7a illustrates in a time diagram the status
5 open/closed of the control switch S_c of the measurement circuit 1 described in Figure 2.

During measurement of the battery voltage V_{bat} , which is initiated at a start time t_0 , the control switch S_c is
10 closed for the time delay period T_{Sc} beginning at the start time t_0 . The time delay period T_{Sc} which is a constant of the time delay circuit 15 (see Figure 2) is defined by means of the time delay controller (see Figures 3-5).

15 Figure 7b illustrates in a time diagram the status open/closed of the time delay switch S_t of the time delay circuit 15 described in Figure 3.

During measurement of the battery voltage V_{bat} and the
20 identification voltage V_{id} , which is initiated at the start time t_0 , the time delay switch S_t is closed for a time period T_{St} beginning at the start time t_0 .

Figure 7c illustrates in a time diagram the potential at the
25 dividing connection 16 between the in series connected resistors R_1 , R_2 , i.e. the measurement voltage V_m , according to an embodiment of the present invention where the time delay switch S_t consists of a CMOS-transistor (see Figure 4).

30 During measurement of the battery voltage V_{bat} , which is initiated at the start time t_0 , the control switch S_c and the time delay switch S_t are closed for a time period T_{Sc} beginning at the start time t_0 (see Figure 7a and Figure
35 7b). Likewise, the identification voltage V_{id} is measured during the time period T_{Vid} while the control switch S_c is

open and the time delay switch St is closed (see Figures 7a and 7b).

Figure 7d illustrates in a time diagram the potential at the dividing connection 16 between the in series connected resistors $R1$, $R2$, i.e. the measurement voltage Vm , according to an embodiment of the present invention where the time delay controller 310 consists of the capacitor 24 (see Figure 5).

10

Just like in Figure 7c, during measurement of the battery voltage $Vbat$, which is initiated at the start time $t0$, both the control switch Sc and the time delay switch St are closed for a time period TSc beginning at the start time $t0$ (see Figures 7a and 7b). Likewise, the identification voltage Vid is measured during the time period $TVid$ while the control switch Sc is open and the time delay switch St is closed (see Figures 7a and 7b). However, in contrast with the measurement of the identification voltage Vid described in Figure 7c, the identification voltage Vid is slightly decreasing during and after measurement of the identification voltage Vid .

15

20

Figure 7e illustrates in a time diagram a total current consumption IC of the measurement circuit 1 and the battery circuit 14.

25

The total current consumption IC of the measurement circuit has a value $I1$ during measurement of the battery voltage $Vbat$ and a value $I2$ during measurement of the identification voltage Vid (see Figures 7c and 7d).

30

As mentioned the mobile station 110 requires only three connections to the battery equipment 120 namely the battery voltage connection 9, the measurement and control connection 10 and the ground connection 11. The measurements described

35

in connection with Figure 7 are performed with only these three connections.

Figure 8 illustrates in a diagram examples of how the division ratio between the resistance of different in series connected resistors R1, R2 of the battery circuit 14 illustrated in Figure 2 can vary in different embodiments of the present invention.

In order to distinguish different battery types from each other, the battery identification voltage Vid vary between different intervals for different types of batteries, i.e. the value of the identification voltage Vid is different for different types of batteries. As can be seen in the diagram in Figure 8, the identification voltage Vid can for instance be

$(0.6-0.7) \cdot V_{bat}$ for a first battery type 1,

$(0.7-0.8) \cdot V_{bat}$ for a second battery type 2, and

$(0.8-0.9) \cdot V_{bat}$ for a third battery type 3.

The interval $(0.9-1.0) \cdot V_{bat}$ is reserved for closing the time delay switch St, i.e. the inverter 420 has a voltage threshold of $0,9 \cdot V_{bat}$ (see Figure 2).

In the diagram in Figure 8, the battery identification voltage Vid is a division ratio $Z \cdot V_{bat}$ of the battery voltage Vbat. A resistor R1 of the in series connected resistors R1, R2 which is connected to the battery voltage connection 9 has a predetermined first resistance X1. The second resistor R2 of the in series connected resistors R1, R2 which is connected to ground 12 has a predetermined second resistance X2.

In Figure 8 the division ratio $Z \cdot V_{bat}$ is calculated as $(X_2 / (X_1 + X_2)) \cdot V_{bat}$, i.e. $V_{id} = (X_2 / (X_1 + X_2)) \cdot V_{bat}$.

Figure 9 illustrates in a scheme an embodiment of the
5 battery circuit 14 of the present invention.

In Figure 9 there is a second time delay circuit 15B besides
the first time delay circuit 15 (see Figure 3). The first
time delay circuit 15 is connected to the first and second
10 in series connected resistors R1, R2. The second time delay
circuit 15B is connected to the battery voltage connection
9, to the measurement and control connection 10 and to two
in series connected resistors. The two resistors connected
to the second time delay circuit 15B are a third resistor R3
15 in series connected with the second resistor R2 being
connected to ground 12. There is a dividing connection 16
between the first and second in series connected resistors
R1, R2 (see Figure 2). The current I_r passes the first in
series connected resistor R1 on identifying and a current I_{r3}
20 passes the third in series connected resistor R3 on
identifying.

Each of the resistors in Figure 9 has a predetermined
resistance. As described in Figure 8 the first resistor R1
25 has the first resistance X_1 and the second resistor R2 has
the second resistance X_2 . Accordingly, the third resistor R3
has a third resistance X_3 .

In Figure 9, the measurement circuit 1 is initiating
30 measurement of two identification voltages V_{id} ; first a
first identification voltage and then a second
identification voltage. The values of the measured
identification voltages differ from each other, and for
instance can the intervals for the different values of the
35 identification voltages be $(0,7-0,8) \cdot V_{bat}$ and $(0,8-$
 $0,9) \cdot V_{bat}$.

Also in Figure 9, as described in Figure 8, the battery identification voltage V_{id} is a division ratio $Z \cdot V_{bat}$ of the battery voltage V_{bat} . In Figure 9 the division ratio $Z \cdot V_{bat}$ is calculated as $(X_2 / (X_1 + X_2)) \cdot V_{bat}$ for the first
5 identification voltage when the first time delay circuit 15 is used for the measurement. The division ratio $Z \cdot V_{bat}$ is calculated as $(X_2 / (X_2 + X_3)) \cdot V_{bat}$ for the second identification voltage when the second time delay circuit 15B is used for
10 the measurement.

It is to be understood that it is within the scope of the present invention to implement at least a third time delay circuit in the same way as the second time delay circuit 15B is implemented in Figure 9.
15

Figure 10 illustrates in a scheme an embodiment of the battery circuit 14 of the present invention.

20 In Figure 10 there are three resistors R_1 , R_2 , R_5 connected between the battery voltage connection 9 (see Figure 2) and ground 12 on identifying, i.e. during measurement of the identification voltage V_{id} and the battery voltage V_{bat} which are the values of the measurement voltage V_m during
25 the time periods T_{Sc} and T_{Vid} , respectively (see Figures 7a-7d). Two of these resistors R_1 , R_5 , which are connected to the battery voltage connection 9 on identifying, are connected in parallel with each other. The advantage with this embodiment is that the interval for the value of the
30 identification voltage V_{id} can be adjusted more easily since resistors can be added in parallel with each other.

In other embodiments of the measurement circuit 1, more than one resistor is connected in parallel with the first
35 resistor R_1 connected to the battery voltage connection on identifying.

In the same way as at least another resistor can be connected in parallel with the first resistor R1 connected to the battery voltage connection 9 on identifying, at least
5 another resistor can as well be connected in parallel with the second resistor R2 connected to ground.

In further embodiments of the present invention at least another resistor can be connected in parallel and/or in
10 series with the first resistor R1 connected to the battery voltage connection 9 on identifying, and also at least another resistor can be connected in parallel and/or in series with the second resistor R2 connected to ground 12.

15 Figure 11a illustrates in a flowchart a method for identifying a predetermined type of battery according to the present invention. The reference signs referred to in the following text are found in Figure 2.

20 The method in Figure 11a starts at a start position 130. In a next step 131 measurement of the battery voltage V_{bat} is initiated by means of closing the control switch S_c and the time delay switch S_t . In a next step 132 the battery voltage V_{bat} is measured by means of the analogue-to-digital
25 converter ADC comprised in the measurement circuit 1. In a next step 133 measurement of the identification voltage V_{id} is initiated by means of opening the control switch S_c . Thereafter in a step 134 the identification voltage V_{id} is generated by means of the in series connected resistors R1,
30 R2. In a next step 135 the identification voltage V_{id} is measured by means of the analogue-to-digital converter ADC. Thereafter the time delay switch is opened in a step 136. Finally, the method ends in an end position 137.

Figure 11b illustrates in a flowchart a method for measuring the temperature of the battery circuit according to the present invention. The temperature of the battery circuit is in practice the same as the temperature of the battery. The reference signs referred to in the following text are found in Figure 2 and Figure 6.

The method in Figure 11b starts at a start position 140. In a next step 141 a predetermined current I is delivered from the current generator 25 through the in series connected resistor $R2$ wherein the in series connected resistors $R1$, $R2$ have a common well defined temperature coefficient. In a next step 142 the temperature of the battery circuit 14 is measured by measuring the measurement voltage V_m and calculating the temperature; since the measurement voltage V_m is measured, the current $I_R=I$ is known and the temperature coefficients of the in series connected resistors $R1$, $R2$ are known it is possible to calculate the temperature of the battery circuit. The method in Figure 11b ends at an end position 143.

CLAIMS

1. A battery identification arrangement including a measurement circuit (1), a battery circuit (14) and a battery (13) having a battery voltage (Vbat), which battery identification arrangement is arranged for identifying a predetermined type of battery (13), wherein the measurement circuit (1) measures predetermined battery circuit characteristics, the battery identification arrangement being provided with a ground connection (11), a measurement and control connection (10) and a battery voltage connection (9), the battery (13) having poles being connected to the battery voltage connection (9) and to ground (12) respectively, and the battery circuit (14) and the measurement circuit (1) being connected to the ground connection (11), to the measurement and control connection (10) and to the battery voltage connection (9), characterized in that at least a first and a second resistor (R1, R2) are arranged in series connection and on identifying are connected between the ground (12) and the battery voltage connection (9), the first resistor (R1) being connected to the battery voltage connection (9), wherein at least one of the resistors (R1, R2) is included in the battery circuit (14) and wherein at least one identification voltage (Vid) is generated by means of the resistors (R1, R2), and that means in the measurement circuit (1) is arranged for measuring the battery voltage (Vbat) and measuring said at least one identification voltage (Vid).

30

2. A battery identification arrangement according to claim 1, characterized in that said at least first and second resistors (R1, R2) are included in the in the battery circuit (14).

35

3. A battery identification arrangement according to anyone
of claims 1 or 2,
c h a r a c t e r i s e d i n t h a t a t i m e d e l a y c i r c u i t
(15) is connected between the battery voltage connection (9)
5 and said at least first and second series connected
resistors (R1, R2), wherein the time delay circuit (15) has
a control input (320; G) which is connected to the
measurement and control connection (10) which is connected
to a dividing connection (16) between two of said at least
10 first and second series connected resistors (R1, R2).

4. A battery identification arrangement according to anyone
of claims 1 or 2,
c h a r a c t e r i s e d i n t h a t a t l e a s t t w o t i m e d e l a y
15 circuits (15, 15B) are connected between the battery voltage
connection (9) and at least each of the first respective a
third resistor (R1, R3), said first and third resistors (R1,
R3) being connected in series with at least the second
resistor (R2), wherein each of the at least two time delay
20 circuits (15, 15B) have each a control input (320; G) which
are connected to the measurement and control connection (10)
which is connected to a dividing connection (16) between two
of said at least first and second series connected resistors
(R1, R2) and between the third and second series connected
25 resistors (R3, R2).

5. A battery identification arrangement according to anyone
of claims 3 or 4,
c h a r a c t e r i s e d i n t h a t t h e t i m e d e l a y c i r c u i t
30 (15) comprises a time delay switch (St) and a time delay
controller (310), wherein the time delay switch (St) is
connected between the battery voltage connection (9) and at
least the first resistor (R1), and wherein the time delay
controller (310) is connected to the control input (320; G)
35 of the time delay switch (St) and to the measurement and
control connection (10).

6. A battery identification arrangement according to claim 5,
c h a r a c t e r i s e d i n that the time delay switch
5 (St) comprises a transistor (410) and that the time delay
controller (310) comprises an inverter (420) and a diode
(21) having a cathode (22) and an anode (23), and that the
time delay controller (310) further comprises a resistor
(20) and a capacitor (19) respectively connected between the
10 anode (23) of the diode (21) and the battery voltage
connection (9), wherein the anode (23) of the diode (21) is
connected to the control input (G) of the transistor (410)
and wherein the inverter (420) is connected between the
cathode (22) of the diode (21) and the measurement and
15 control connection (10).

7. A battery identification arrangement according to anyone
of claims 3 or 4,
c h a r a c t e r i s e d i n that the time delay circuit
20 (15) comprises a time delay switch (St) and a time delay
controller (310), wherein the time delay switch (St) is
connected between the battery voltage connection (9) and at
least the first resistor (R1), wherein the control input
(320) of the time delay switch (St) is connected to the
25 measurement and control connection (10) and wherein the time
delay controller (310) is connected in parallel to the time
delay switch (St).

8. A battery identification arrangement according to
30 claim 7,
c h a r a c t e r i s e d i n that the time delay
controller (310) consists of a capacitor (24).

9. A battery identification arrangement according to anyone
35 of claims 5-8,

characterised in that a time delay period (TSc) of the time delay circuit (15) is defined by means of the time delay controller (310).

5 10. A battery identification arrangement according to anyone of claims 5-9,

characterised in that the measurement circuit (1) comprises an analogue-to-digital converter (ADC), a control switch (Sc) and a controller (2) which is arranged
10 for controlling the analogue-to-digital converter (ADC) and the control switch (Sc), wherein the control switch (Sc) is connected to the battery voltage connection (9) and to the measurement and control connection (10), and the analogue-to-digital converter (ADC) is connected to the measurement
15 and control connection (10).

11. A battery identification arrangement according to claim 10,

characterised in that the measurement circuit
20 (1) is arranged for initiating measurement of said at least one identification voltage (Vid) and the battery voltage (Vbat), wherein the control switch (Sc) and the time delay switch (St) are closed.

25 12. A battery identification arrangement according to anyone of claims 1-11,

characterised in that at least three resistors (R1, R2, R3) on identifying are connected between the ground
(12) and the battery voltage connection (9).

30 13. A battery identification arrangement according to claim 12,

characterised in that at least two of the resistors (R1, R3) are connected in parallel with each
35 other.

14. A battery identification arrangement according to claim 12,
characterised in that said at least three resistors are connected in series with each other.

5

15. A battery identification arrangement according to anyone of claims 1-14,
characterised in that the resistance of the in series connected resistors (R1, R2) vary with the
10 temperature.

16. A battery identification arrangement according to claim 15,
characterised in that the measurement circuit
15 (1) also comprises a current generator (25) connected to the battery voltage connection (9) and to the measurement and control connection (10), wherein the current generator (25) is arranged for delivering a predetermined current (I) through one of the in series connected resistors (R2) for
20 measuring the temperature of the battery circuit (14).

17. A battery identification arrangement according to anyone of claims 1-3 or 5-16,
characterised in that said first resistor (R1)
25 has a predetermined first resistance (X₁) and said second resistor has a predetermined second resistance (X₂), wherein the identification voltage (V_{id}) is a division ratio (Z*V_{bat}) of the battery voltage (V_{bat}), the identification voltage (V_{id}) being generated by the first and second
30 resistors (R1, R2), wherein the value of the identification voltage (V_{id}) is different for different types of batteries (13).

18. A battery identification arrangement according to anyone
35 of claims 4-16,

characterised in that said first and third resistors (R1, R3) have each a predetermined resistance (X_1 , X_3) and that said second resistor (R2) also has a predetermined resistance (X_2), wherein each of said at least two identification voltages (V_{id}) is a division ratio ($Z \cdot V_{bat}$) of the battery voltage (V_{bat}), the identification voltages (V_{id}) being generated by the first and second (R1, R2) respective third and second resistors (R3, R2), wherein the values of the identification voltages (V_{id}) are different for different types of batteries (13) and wherein the measurement circuit (1) is initiating measurement of at least two identification voltages (V_{id}).

19. A battery identification arrangement according to any one of claims 17 or 18, characterised in that said at least one identification voltage (V_{id}) is within different intervals for different types of batteries (13).

20. A battery identification arrangement according to any one of claims 17 or 19, characterised in that the intervals for the values of the identification voltage (V_{id}) are $(0,6-0,7) \cdot V_{bat}$ for a first battery type (13), $(0,7-0,8) \cdot V_{bat}$ for a second battery type (13) and $(0,8-0,9) \cdot V_{bat}$ for a third battery type (13).

21. A battery identification arrangement according to any one of claims 18 or 19, characterised in that the measurement circuit (1) is initiating measurement of two identification voltages (V_{id}), wherein the intervals for the values of the identification voltages (V_{id}) are $(0,7-0,8) \cdot V_{bat}$ and $(0,8-0,9) \cdot V_{bat}$, respectively.

35

22. A battery identification arrangement according to anyone of claims 1-21,
c h a r a c t e r i s e d i n t h a t t h e m e a s u r e m e n t c i r c u i t
(1) is comprised in an electronic equipment (110).

5

23. A battery identification arrangement according to claim 22,
c h a r a c t e r i s e d i n t h a t t h e e l e c t r o n i c e q u i p m e n t
(110) is a mobile station (110).

10

24. A battery identification arrangement according to claim 22,
c h a r a c t e r i s e d i n t h a t t h e e l e c t r o n i c e q u i p m e n t
(110) is a charger.

15

25. A battery identification arrangement according to anyone of claims 1-24,
c h a r a c t e r i s e d i n t h a t t h e b a t t e r y (13) and the
battery circuit (14) are comprised in a battery equipment
(120).

20

26. A method for identifying a predetermined type of battery (13) using a battery identification arrangement including a measurement circuit (1), a battery circuit (14) and the
battery (13) having a battery voltage (Vbat), the battery identification arrangement being provided with a ground connection (11), a measurement and control connection (10) and a battery voltage connection (9), the battery (13) having poles being connected to the battery voltage
connection (9) and to ground (12) respectively, and the
battery circuit (14) and the measurement circuit (1) being connected to the ground connection (11), to the measurement and control connection (10) and to the battery voltage connection (9), the method comprising the steps of:

35

- measuring predetermined battery circuit characteristics by means of the measurement circuit (1);

c h a r a c t e r i s e d b y

5

- generating at least one identification voltage (Vid) by means of at least a first and a second resistor (R1, R2) connected in series and on identifying being connected between the ground (12) and the battery voltage connection (9), the first resistor (R1) being connected to the battery voltage connection (9) wherein at least one of the resistors (R1, R2) is included in the battery circuit (14); and

- measuring the battery voltage (Vbat) and measuring said at least one identification voltage (Vid) by means of the measurement circuit (1).

27. A method according to claim 26,
c h a r a c t e r i s e d b y generating said at least one identification voltage (Vid), wherein said at least first and a second resistors (R1, R2) are included in the battery circuit (14).

28. A method according to anyone of claims 26 or 27,
c h a r a c t e r i s e d b y generating said at least one identification voltage (Vid), wherein a time delay circuit (15) is connected between the battery voltage connection (9) and said at least first and second series connected resistors (R1, R2), wherein the time delay circuit (15) has a control input (320; G) which is also connected to the measurement and control connection (10) which is connected to a dividing connection (16) between two of said at least first and second series connected resistors (R1, R2).

29. A method according to anyone of claims 26-28,

c h a r a c t e r i s e d b y

- generating at least two identification voltages (Vid),
wherein each of at least two time delay circuits (15, 15B)
5 are connected between the battery voltage connection (9) and
at least each of the first respective a third resistor (R1,
R3), said first and third resistors (R1, R3) being connected
in series with at least the second resistor (R2), wherein
each of the at least two time delay circuits (15, 15B) have
10 each a control input (320; G) which are connected to the
measurement and control connection (10) which is connected
to the dividing connection (16) between two of said at least
first and second series connected resistors (R1, R2) and
between the third and second series connected resistors (R3,
15 R2); and

- measuring said at least two identification voltages (Vid)
after each other.

20 30. A method according to anyone of claims 28 or 29,
c h a r a c t e r i s e d b y controlling a time delay
switch (St) by means of a time delay controller (310),
wherein the time delay circuit (15) comprises the time delay
switch (St) and the time delay controller (310), wherein the
25 time delay switch (St) is connected between the battery
voltage connection (9) and at least the first resistor (R1),
and wherein the time delay controller (310) is connected to
the control input (320; G) of the time delay switch (St) and
to the measurement and control connection (10).

30 31. A method according to claim 30,
c h a r a c t e r i s e d b y controlling the time delay
switch (St) by means of the time delay controller (310),
wherein the time delay switch (St) comprises a transistor
35 (410) and that the time delay controller (310) comprises an
inverter (420) and a diode (21) having a cathode (22) and an

anode (23), and that the time delay controller (310) further comprises a resistor (20) and a capacitor (19) respectively connected between the anode (23) of the diode (21) and the battery voltage connection (9), wherein the anode (23) of
5 the diode (21) is connected to the control input (G) of the transistor (410) and wherein the inverter (420) is connected between the cathode (22) of the diode (21) and the measurement and control connection (10).

10 32. A method according to anyone of claims 28 or 29, characterised by controlling a time delay switch (St) by means of a time delay controller (310), wherein the time delay circuit (15) comprises the time delay
15 time delay switch (St) and the time delay controller (310), wherein the time delay switch (St) is connected between the battery voltage connection (9) and at least the first resistor (R1), wherein the control input (320) of the time delay switch (St) is connected to the measurement and control connection (10) and wherein the time delay controller (310) is
20 connected in parallel to the time delay switch (St).

33. A method according to claim 32, characterised by controlling the time delay switch (St) by means of the time delay controller (310),
25 wherein the time delay controller (310) consists of a capacitor (24).

34. A method according to anyone of claims 30-33, characterised by defining a time delay period
30 (TSc) of the time delay circuit (15) by means of the time delay controller (310).

35 35. A method according to anyone of claims 30-34, characterised by

- 5 - initiating measurement of the battery voltage (Vbat) by means of closing the time delay switch (St) and a control switch (Sc) which is comprised in the measurement circuit (1) and is connected to the battery voltage connection (9) and the measurement and control connection (10);
- 10 - measuring the battery voltage (Vbat) by means of an analogue-to-digital converter (ADC) which is comprised in the measurement circuit (1) and is connected to the measurement and control connection (10);
- initiating measurement of the identification voltage (Vid) by means of opening the control switch (Sc);
- 15 - measuring the identification voltage (Vid) by means of the analogue-to-digital converter (ADC); and
- opening the time delay switch (St).
- 20 36. A method according to claim 35, characterised by controlling the analogue-to-digital converter (ADC) and the control switch (Sc) by means of a controller (2) comprised in the measurement circuit(1).
- 25 37. A method according to anyone of claims 26-36, characterised by generating said at least one identification voltage (Vid), including connecting at least three resistors (R1, R2, R3) on identifying between the ground (12) and the battery voltage connection (9).
- 30 38. A method according to claim 37, characterised by generating said at least one identification voltage (Vid), including connecting at least two of the resistors (R1, R3) in parallel with each other.
- 35 39. A method according to claim 37,

c h a r a c t e r i s e d b y generating said at least one identification voltage (Vid), including connecting said at least three resistors in series with each other.

5 40. A method according to anyone of claims 26-39,

c h a r a c t e r i s e d b y

- delivering a predetermined current (I) through one of the
10 in series connected resistors (R2) by means of a current generator (25) connected to the battery voltage connection (9) and to the measurement and control connection 10, the generator (25) comprised in the measurement circuit (1), wherein the resistance of the in series connected resistors
15 (R1, R2) vary with the temperature; and

- measuring the temperature of the battery circuit (14) by measuring the voltage over said one series connected resistor (R2).

20

41. A method according to anyone of claims 26-28 or 30-40,
c h a r a c t e r i s e d b y generating said at least one identification voltage (Vid), wherein said first resistor (R1) has a predetermined first resistance (X₁) and said
25 second resistor has a predetermined second resistance (X₂), wherein the identification voltage (Vid) is a division ratio (Z*Vbat) of the battery voltage (Vbat), the identification voltage (Vid) being generated by the first and second resistors (R1, R2), wherein the value of the identification
30 voltage (Vid) is different for different types of batteries (13).

42. A method according to anyone of claims 29-40,
c h a r a c t e r i s e d b y generating said at least two
35 identification voltages (Vid), wherein said first and third resistors (R1, R3) have each a predetermined resistance (X₁,

X₃) and that said second resistor (R₂) also has a predetermined resistance (X₂), wherein each of said at least two identification voltages (V_{id}) is a division ratio ($Z \cdot V_{bat}$) of the battery voltage (V_{bat}), the identification voltage (V_{id}) being generated by the first and second (R₁, R₂) respective third and second resistors (R₃, R₂), wherein the values of the identification voltages (V_{id}) are different for different types of batteries (13) and wherein the measurement circuit (1) is initiating measurement of at least two identification voltages (V_{id}).

43. A method according to anyone of claims 41 or 42, characterised by generating said at least one identification voltage (V_{id}), wherein said at least one identification voltage (V_{id}) is within different intervals for different types of batteries (13).

44. A method according to anyone of claims 41 or 43, characterised by generating said at least one identification voltage (V_{id}), wherein the intervals for the values of the identification voltage (V_{id}) are $(0,6-0,7) \cdot V_{bat}$ for a first battery type, $(0,7-0,8) \cdot V_{bat}$ for a second battery type (13) and $(0,8-0,9) \cdot V_{bat}$ for a third battery type (13).

45. A method according to anyone of claims 42 or 43, characterised by generating said at least one identification voltage (V_{id}), wherein the measurement circuit (1) is initiating measurement of two identification voltages (V_{id}), wherein the intervals for the values of the identification voltages (V_{id}) are $(0,7-0,8) \cdot V_{bat}$ and $(0,8-0,9) \cdot V_{bat}$, respectively.

46. A battery equipment (120) including a battery circuit (14) and a battery (13) having a battery voltage (V_{bat}), which battery equipment (120) is arranged for identifying a

predetermined type of battery (13), the battery equipment (120) being provided with a ground connection (11), a measurement and control connection (10) and a battery voltage connection (9), the battery (13) having poles being
5 connected to the battery voltage connection (9) and to ground (12) respectively, the battery circuit (14) being connected to the ground connection (11), to the measurement and control connection (10) and to the battery voltage connection (9),

10 c h a r a c t e r i s e d i n that at least a first and a second resistor (R1, R2) are arranged in series connection and on identifying are connected between the ground (12) and the battery voltage connection (9), the first resistor (R1) being connected to the battery voltage connection (9),
15 wherein at least one of the resistors (R1, R2) is included in the battery circuit (14) and wherein at least one identification voltage (Vid) is generated by means of the resistors (R1, R2).

20 47. A battery equipment (120) according to claim 46, c h a r a c t e r i s e d i n that said at least first and second resistors (R1, R2) are included in the in the battery circuit (14).

25 48. A battery equipment (120) according to anyone of claims 46 or 47, c h a r a c t e r i s e d i n that a time delay circuit (15) is connected between the battery voltage connection (9) and said at least first and second series connected
30 resistors (R1, R2), wherein the time delay circuit (15) has a control input (320; G) which is connected to the measurement and control connection (10) which is connected to a dividing connection (16) between two of said at least first and second series connected resistors (R1, R2).

35

49. A battery equipment (120) according to anyone of claims 46 or 47,

characterised in that at least two time delay circuits (15, 15B) are connected between the battery voltage connection (9) and at least each of the first respective a
5 third resistor (R1, R3), said first and third resistors (R1, R3) being connected in series with at least the second resistor (R2), wherein each of the at least two time delay circuits (15, 15B) have each a control input (320; G) which
10 are connected to the measurement and control connection (10) which is connected to a dividing connection (16) between two of said at least first and second series connected resistors (R1, R2) and between the third and second series connected resistors (R3, R2).

15

50. A battery equipment (120) according to anyone of claims 48 or 49,

characterised in that the time delay circuit (15) comprises a time delay switch (St) and a time delay
20 controller (310), wherein the time delay switch (St) is connected between the battery voltage connection (9) and at least the first resistor (R1), and wherein the time delay controller (310) is connected to the control input (320; G) of the time delay switch (St) and to the measurement and
25 control connection (10).

51. A battery equipment (120) according to claim 50,

characterised in that the time delay switch (St) comprises a transistor (410) and that the time delay
30 controller (310) comprises an inverter (420) and a diode (21) having a cathode (22) and an anode (23), and that the time delay controller (310) further comprises a resistor (20) and a capacitor (19) respectively connected between the anode (23) of the diode (21) and the battery voltage
35 connection (9), wherein the anode (23) of the diode (21) is connected to the control input (G) of the transistor (410)

and wherein the inverter (420) is connected between the cathode (22) of the diode (21) and the measurement and control connection (10).

5 52. A battery equipment (120) according to anyone of claims 48 or 49,
c h a r a c t e r i s e d i n that the time delay circuit (15) comprises a time delay switch (St) and a time delay controller (310), wherein the time delay switch (St) is
10 connected between the battery voltage connection (9) and at least the first resistor (R1), wherein the control input (320) of the time delay switch (St) is connected to the measurement and control connection (10) and wherein the time
15 delay controller (310) is connected in parallel to the time delay switch (St).

53. A battery equipment (120) according to claim 52,
c h a r a c t e r i s e d i n that the time delay controller (310) consists of a capacitor (24).

20

54. A battery equipment (120) according to anyone of claims 50-53,
c h a r a c t e r i s e d i n that a time delay period (TSc) of the time delay circuit (15) is defined by means of
25 the time delay controller (310).

55. A battery equipment (120) according to anyone of claims 46-54,
c h a r a c t e r i s e d i n that at least three resistors
30 (R1, R2, R3) on identifying are connected between the ground (12) and the battery voltage connection (9).

56. A battery equipment (120) according to claim 55,
c h a r a c t e r i s e d i n that at least two of the
35 resistors (R1, R3) are connected in parallel with each other.

57. A battery equipment (120) according to claim 55,
characterised in that said at least three
resistors are connected in series with each other.

5

58. A battery equipment (120) according to anyone of
claims 46-57,
characterised in that the resistance of the in
series connected resistors (R1, R2) vary with the
10 temperature.

59. A battery equipment (120) according to anyone of
claims 46-48 or 50-58,
characterised in that said first resistor (R1)
15 has a predetermined first resistance (X_1) and said second
resistor has a predetermined second resistance (X_2), wherein
the identification voltage (Vid) is a division ratio
($Z \cdot V_{bat}$) of the battery voltage (V_{bat}), the identification
voltage (Vid) being generated by the first and second
20 resistors (R1, R2), wherein the value of the identification
voltage (Vid) is different for different types of batteries
(13).

60. A battery equipment (120) according to anyone of
25 claims 49-58,
characterised in that said first and third
resistors (R1, R3) have each a predetermined resistance (X_1 ,
 X_3) and that said second resistor (R2) also has a
predetermined resistance (X_2), wherein each of said at least
30 two identification voltages (Vid) is a division ratio
($Z \cdot V_{bat}$) of the battery voltage (V_{bat}), the identification
voltages (Vid) being generated by the first and second (R1,
R2) respective third and second resistors (R3, R2), wherein
the values of the identification voltages (Vid) are
35 different for different types of batteries (13) and wherein

the measurement circuit (1) is initiating measurement of at least two identification voltages (Vid).

5 61. A battery equipment (120) according to any one of claims 59 or 60, characterized in that said at least one identification voltage (Vid) is within different intervals for different types of batteries (13).

10 62. A battery equipment (120) according to any one of claims 59 or 61, characterized in that the intervals for the values of the identification voltage (Vid) are $(0,6-0,7)*V_{bat}$ for a first battery type (13), $(0,7-0,8)*V_{bat}$ for a
15 second battery type (13) and $(0,8-0,9)*V_{bat}$ for a third battery type (13).

63. A battery equipment (120) according to any one of claims 60 or 61,
20 characterized in that the measurement circuit (1) is initiating measurement of two identification voltages (Vid), wherein the intervals for the values of the identification voltages (Vid) are $(0,7-0,8)*V_{bat}$ and $(0,8-0,9)*V_{bat}$, respectively.

25

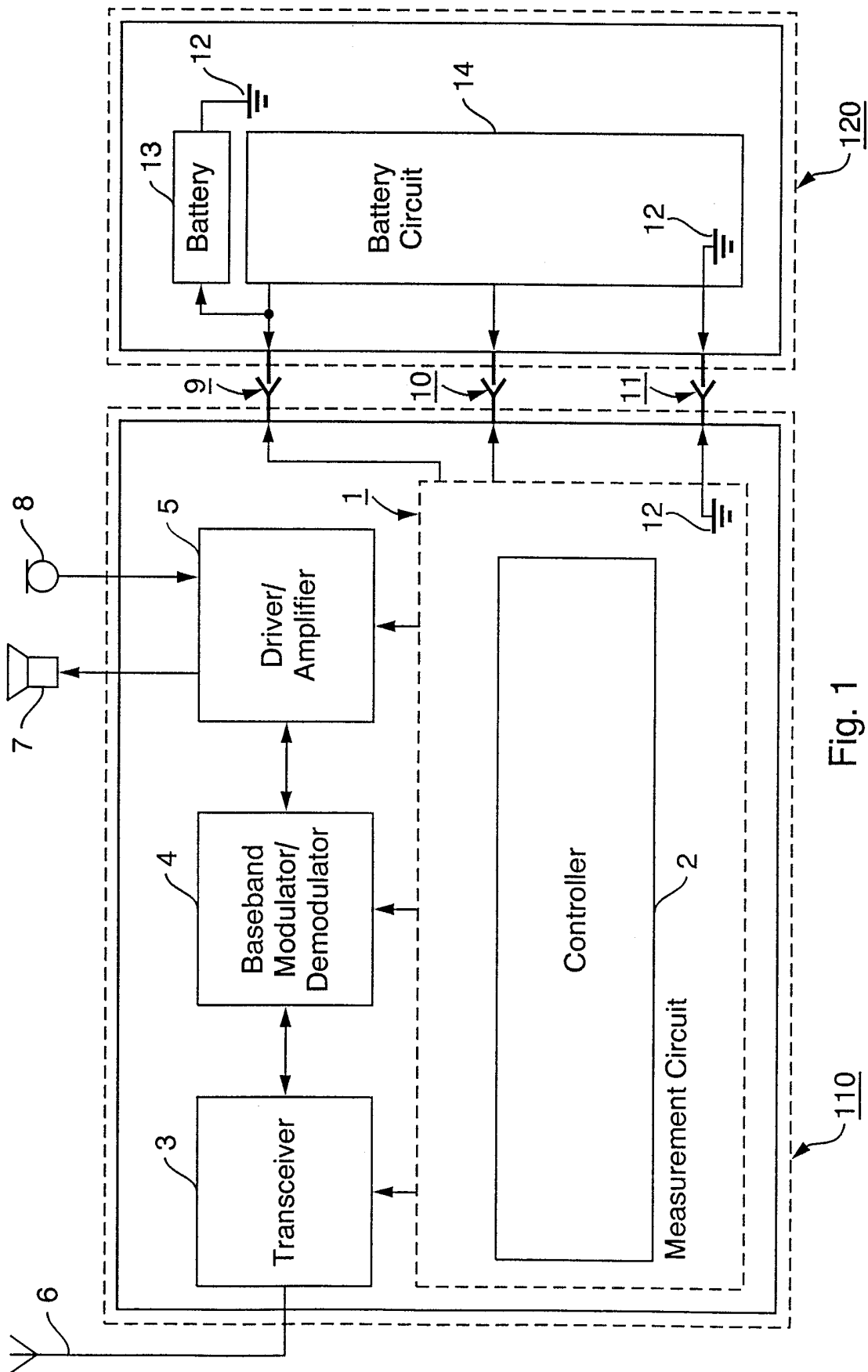

Fig. 1

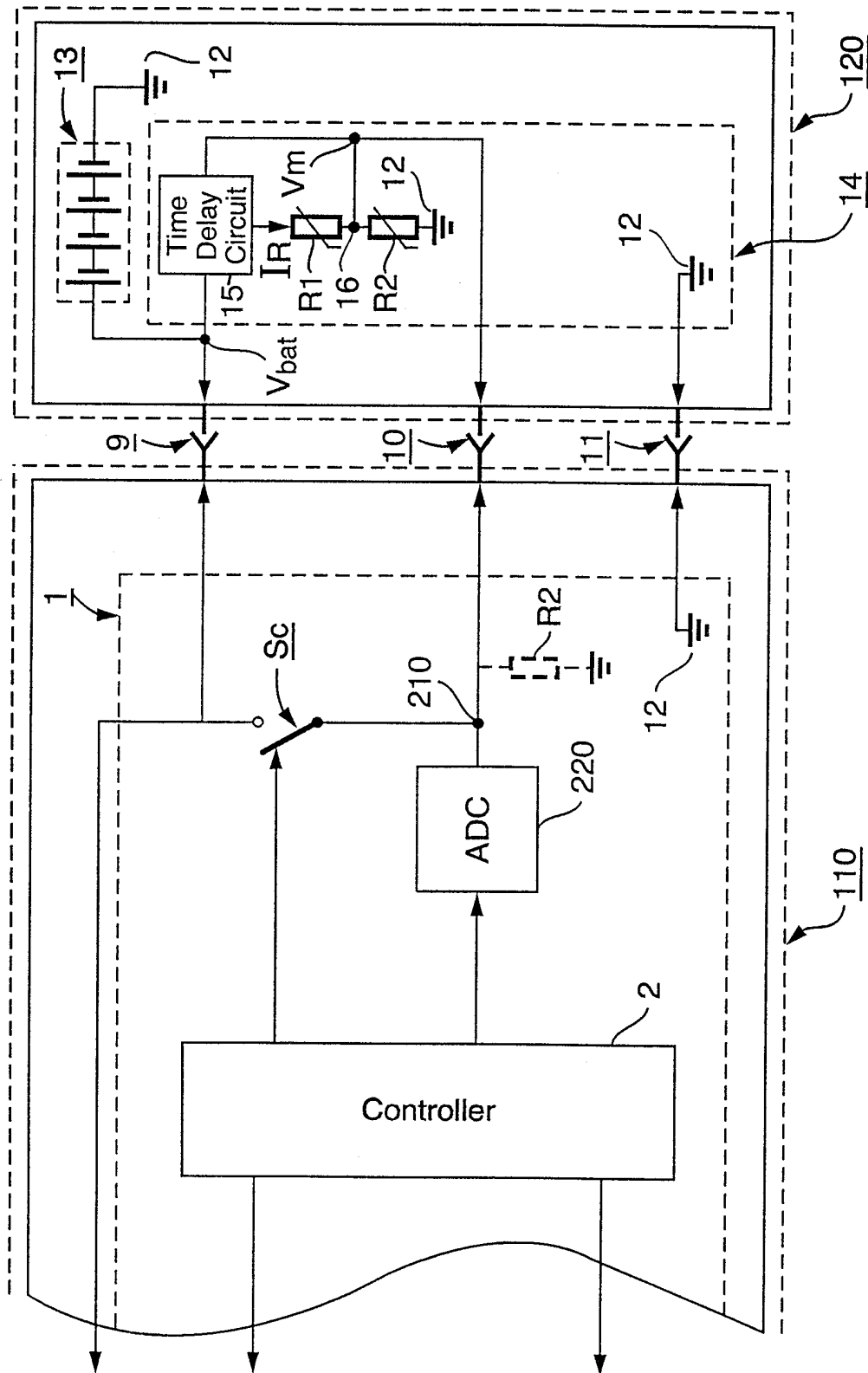

Fig. 2

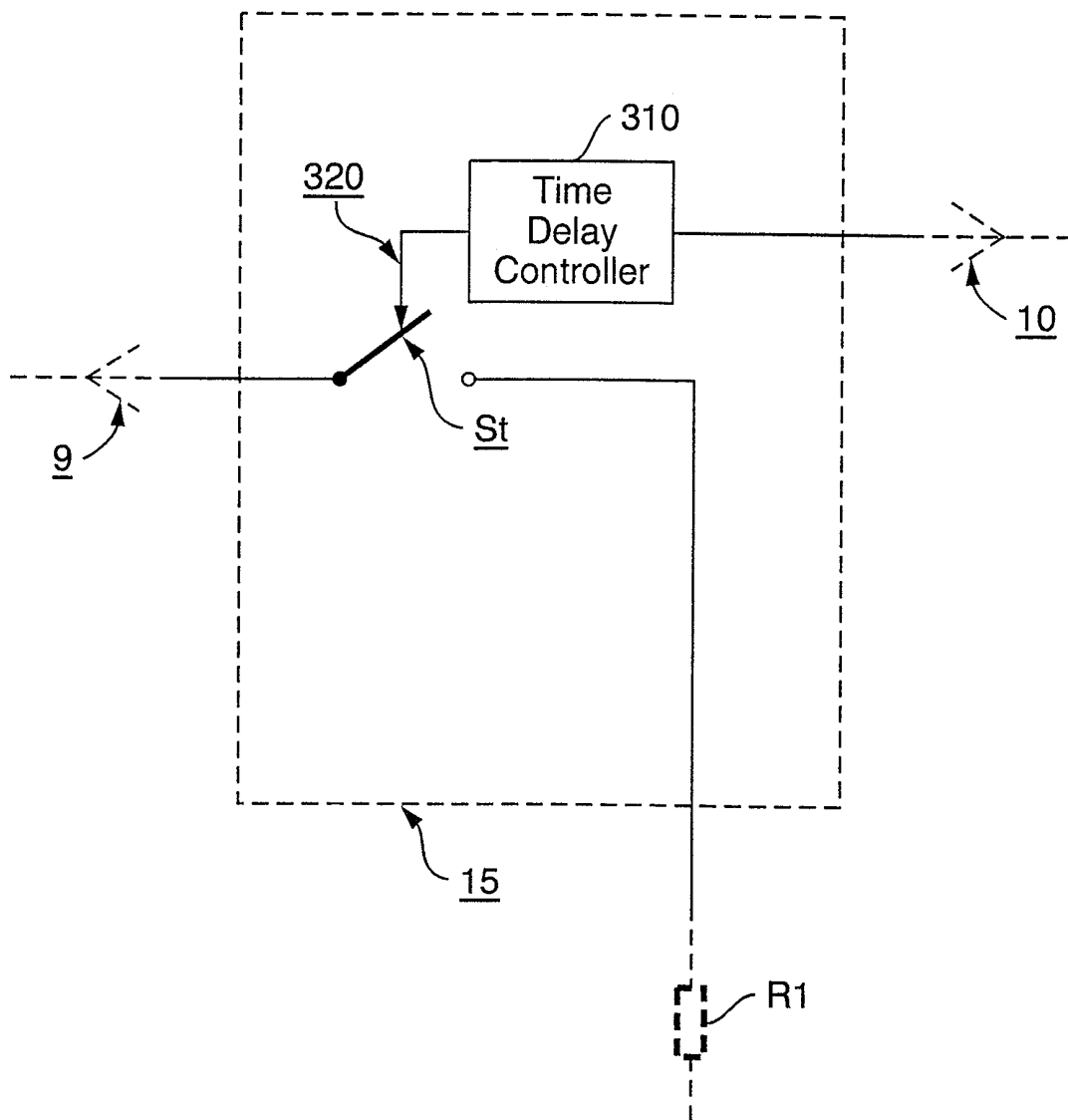

Fig. 3

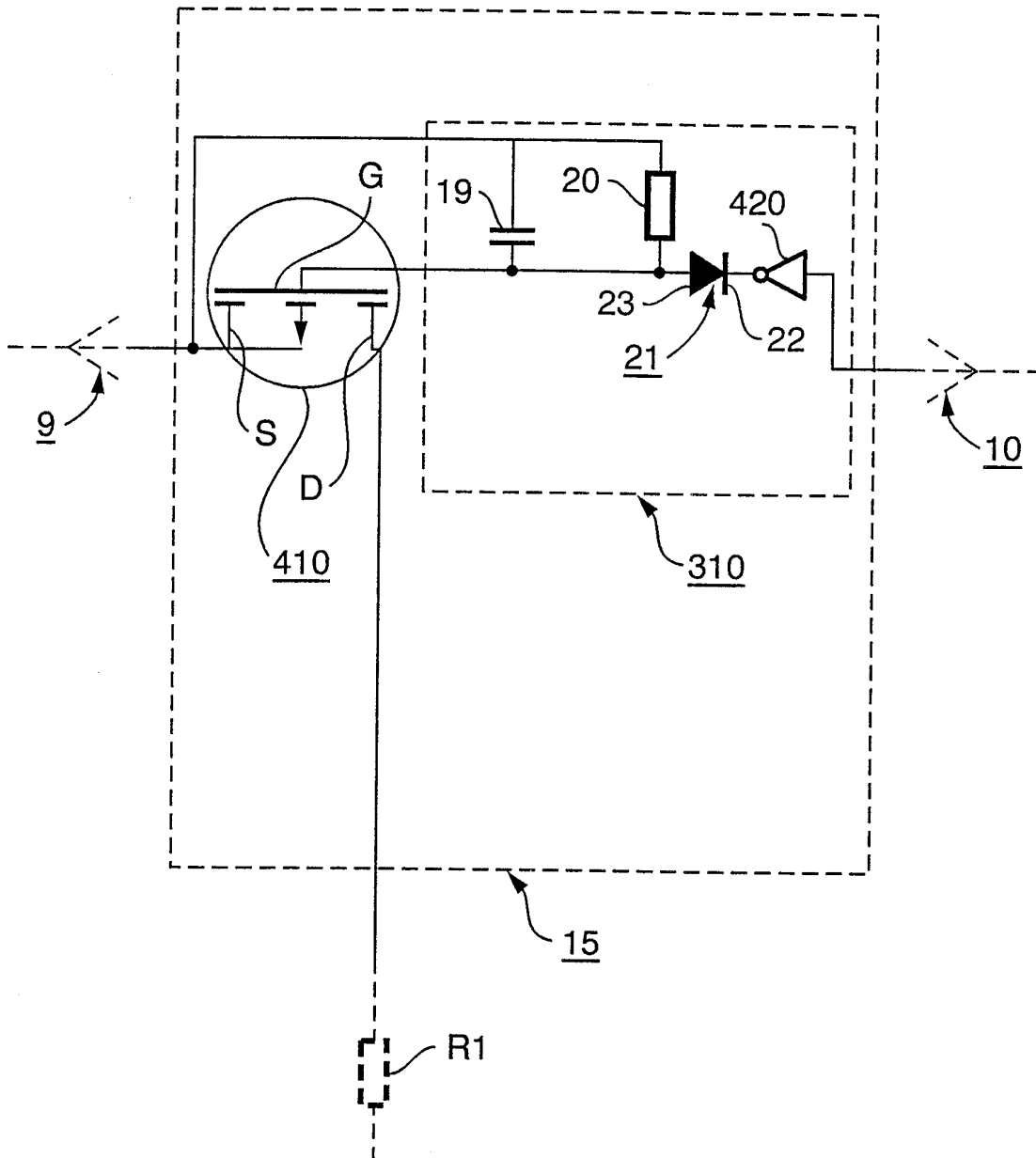

Fig. 4

5/11

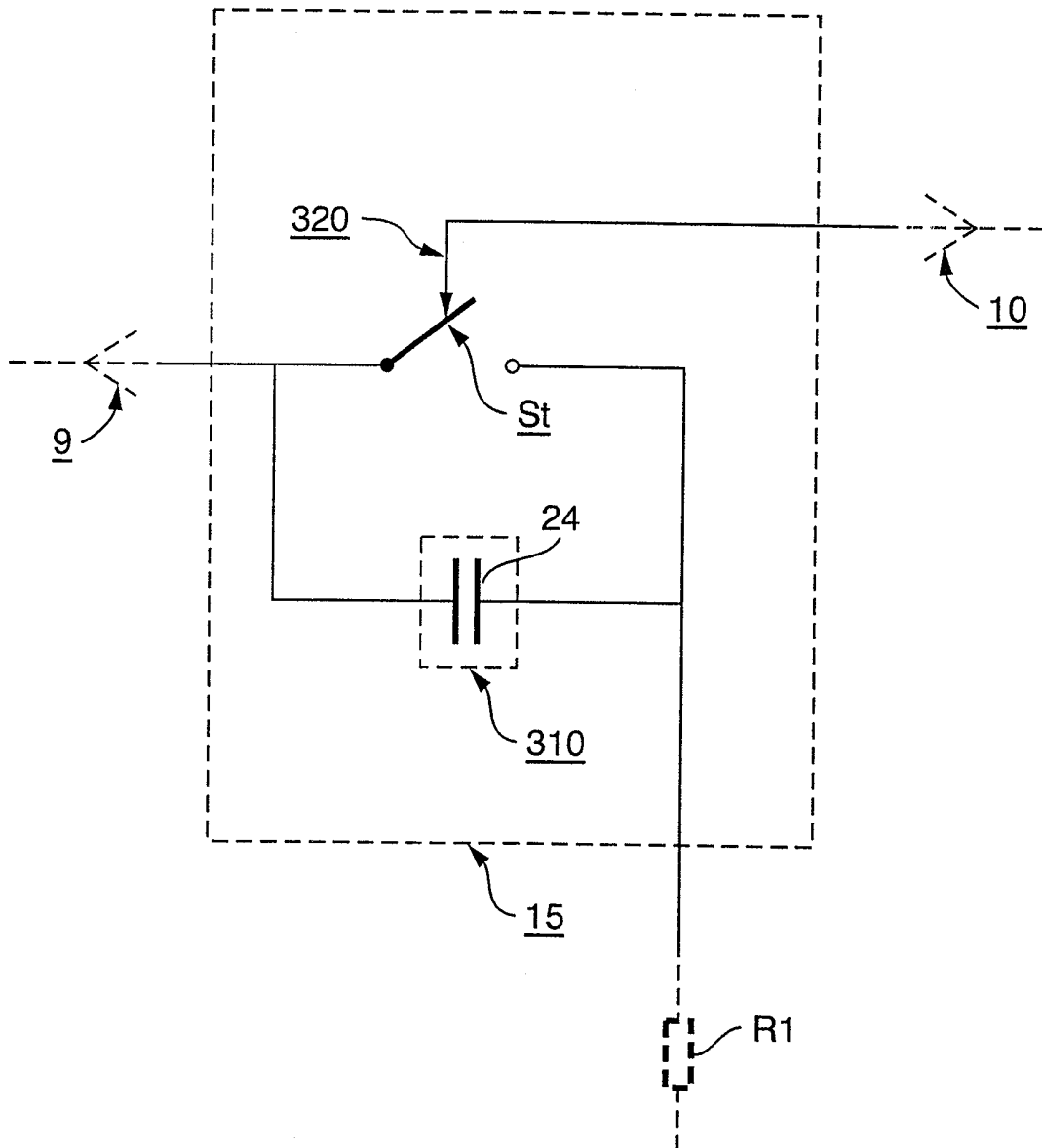

Fig. 5

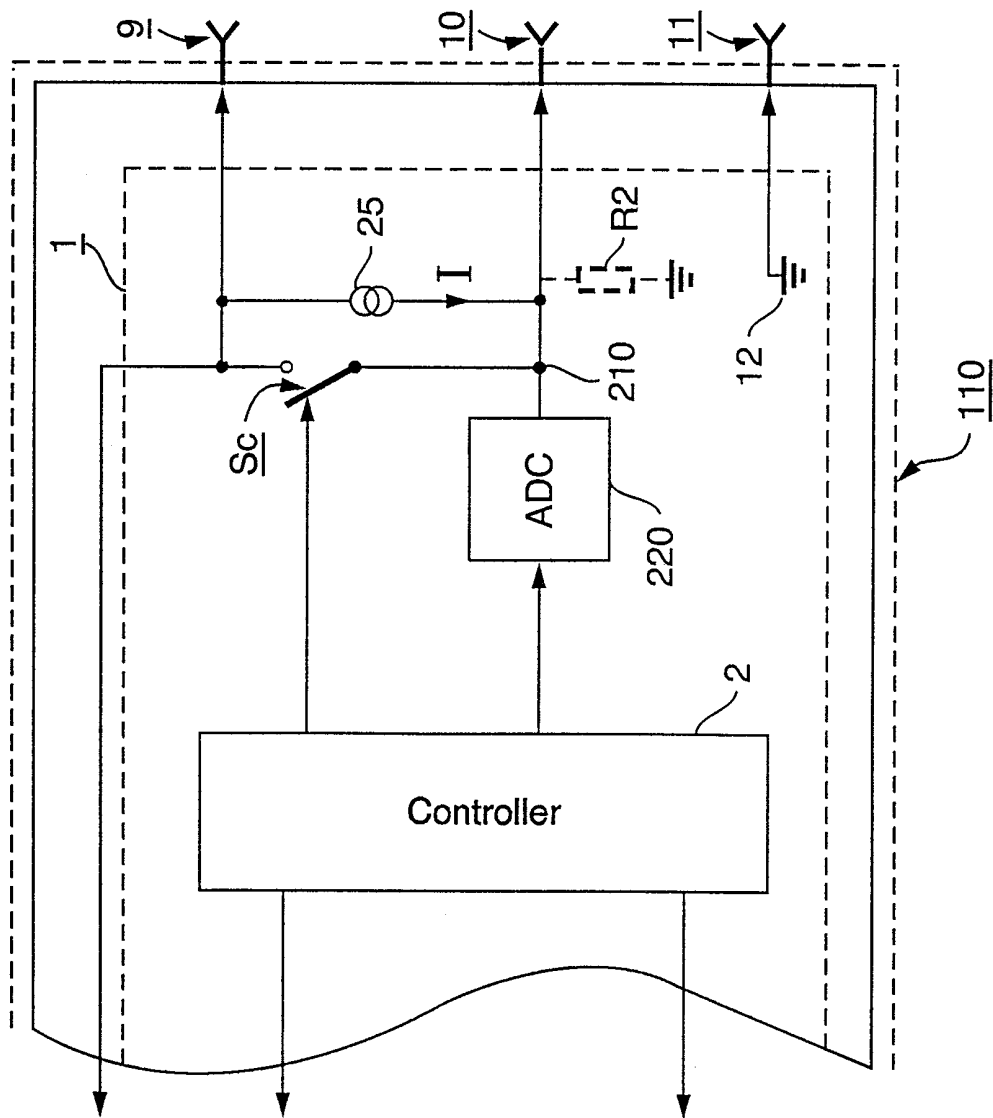
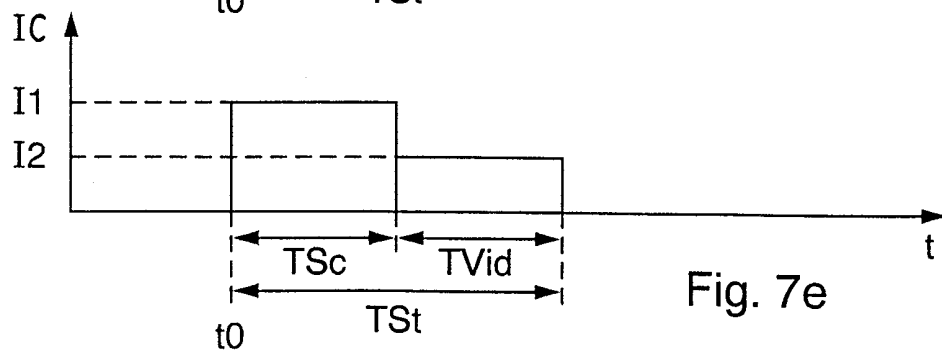
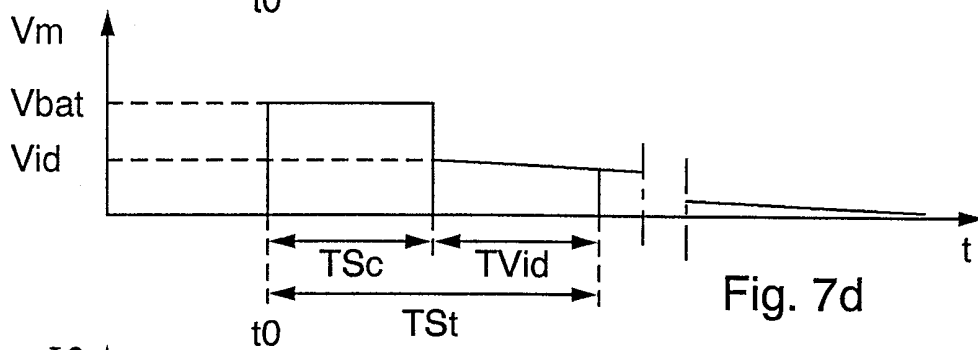
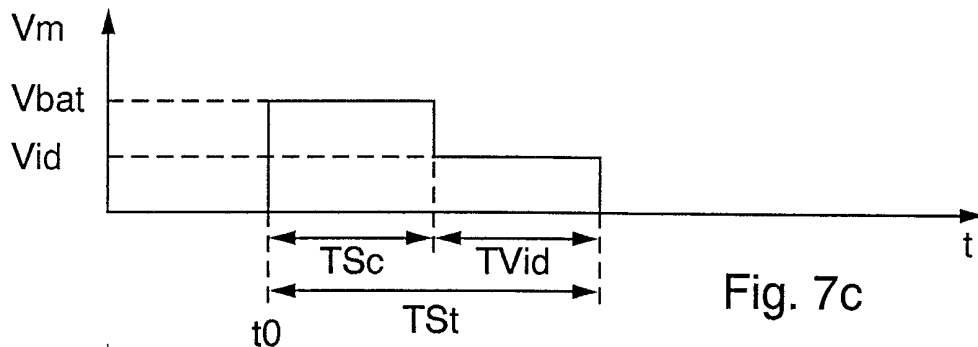
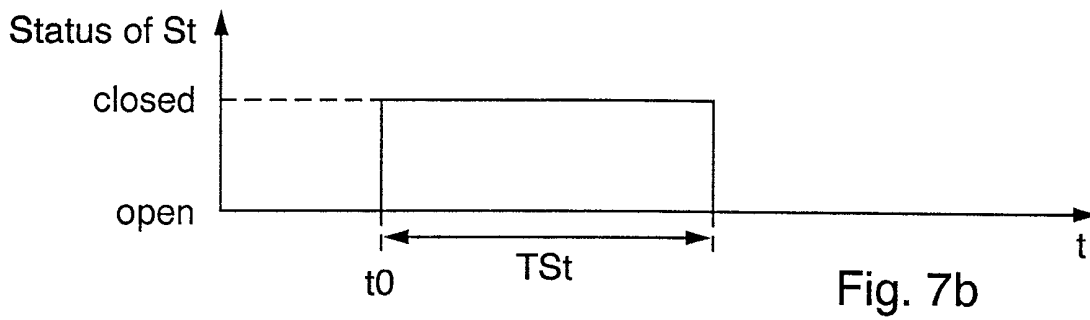
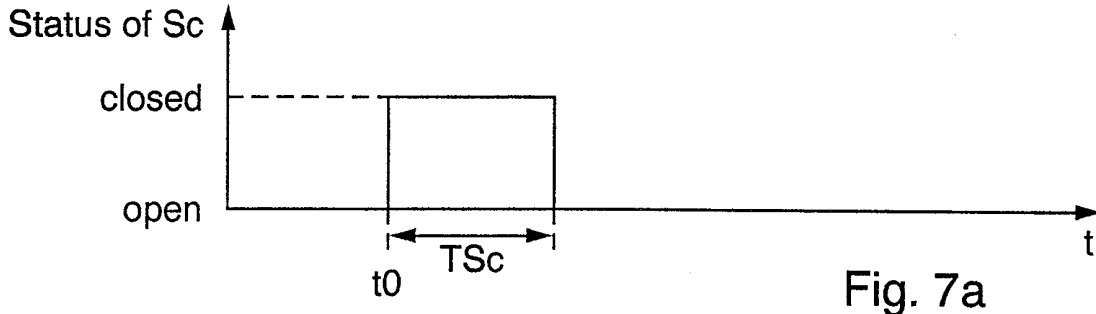

Fig. 6



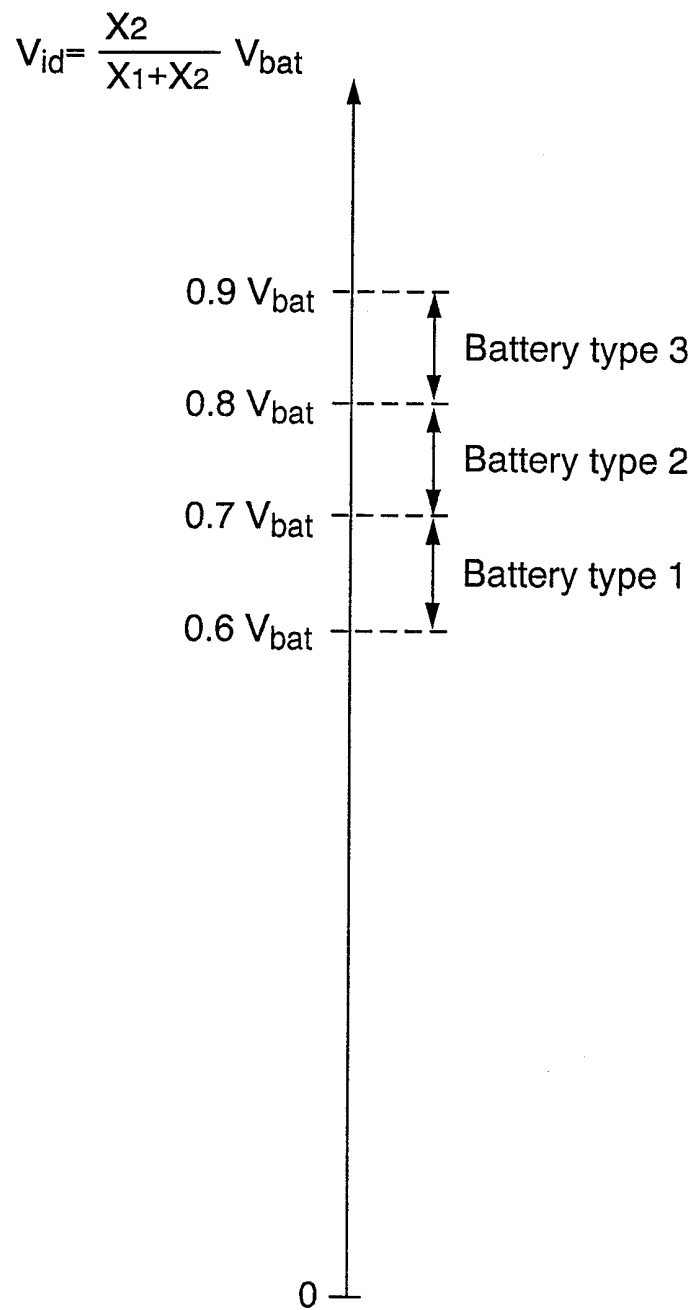

Fig. 8

9/11

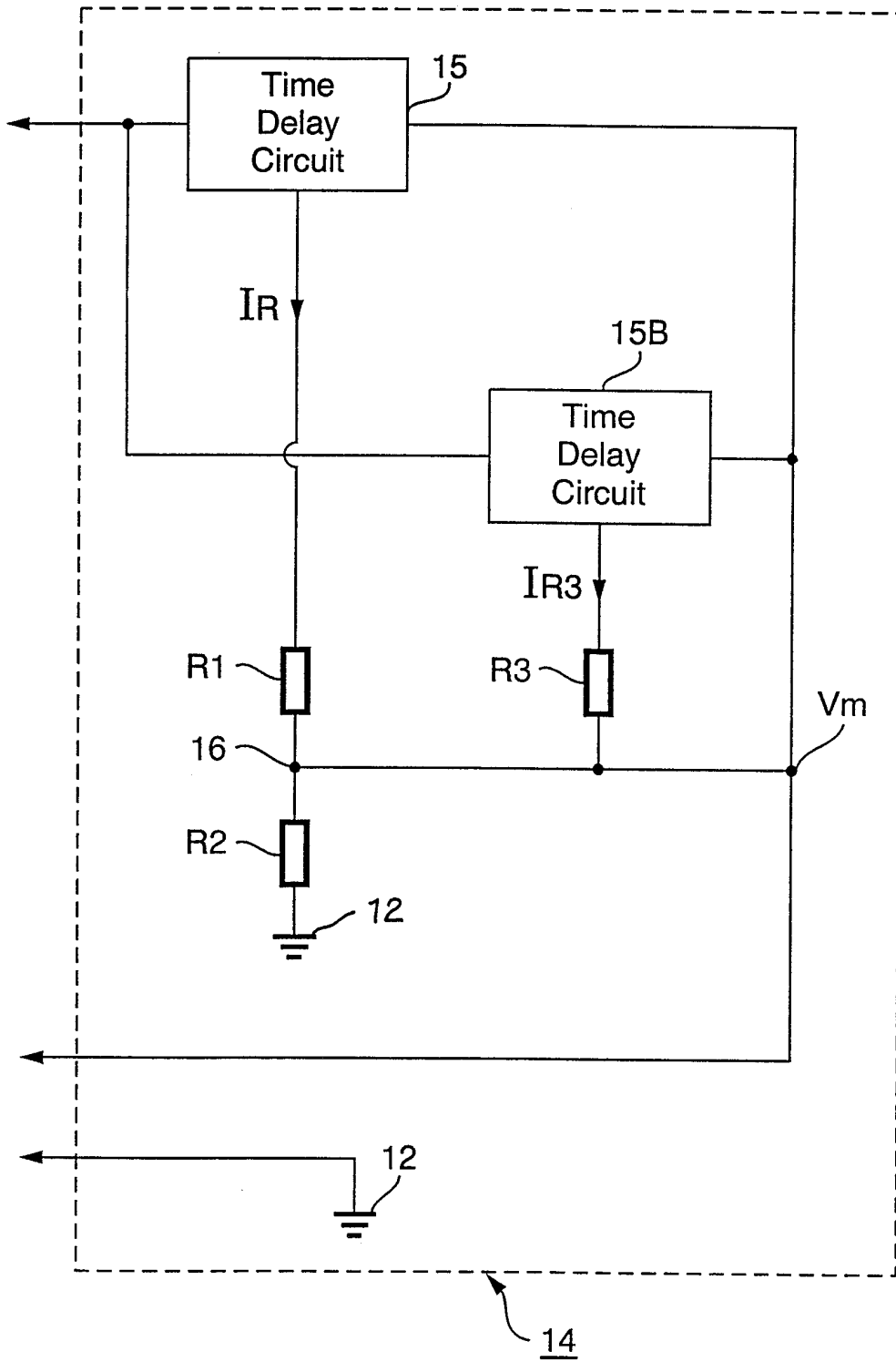

Fig. 9

10/11

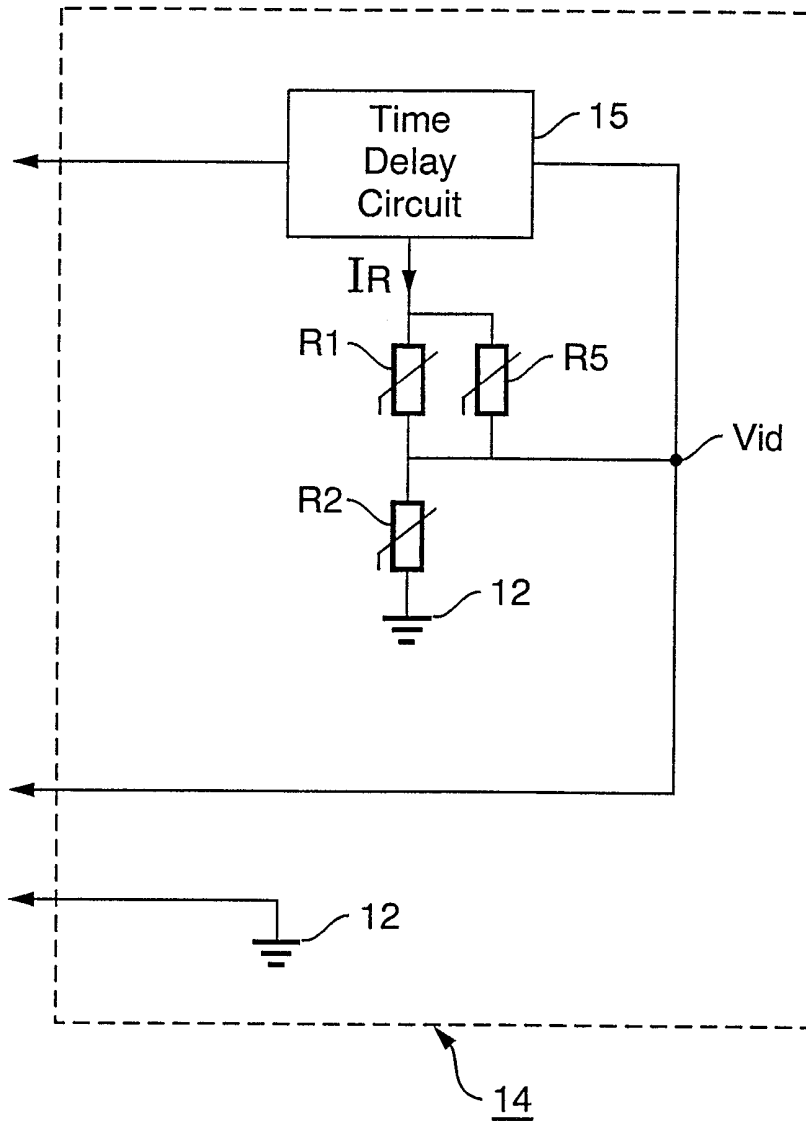

Fig. 10

11/11

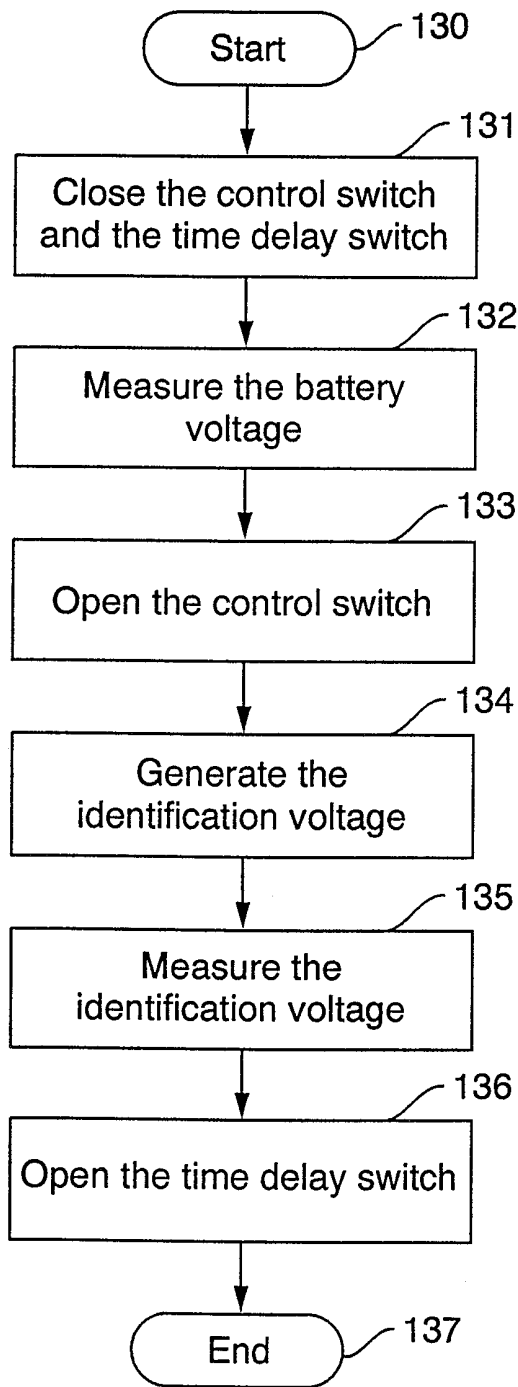

Fig. 11a

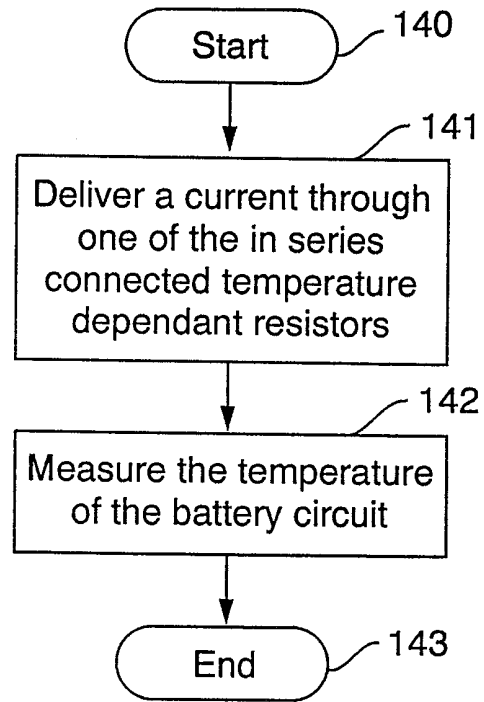

Fig. 11b

INTERNATIONAL SEARCH REPORT

International application No.

PCT/SE 98/01942

A. CLASSIFICATION OF SUBJECT MATTER		
IPC6: H02J 7/00, H01M 10/48 According to International Patent Classification (IPC) or to both national classification and IPC		
B. FIELDS SEARCHED		
Minimum documentation searched (classification system followed by classification symbols)		
IPC6: H02J, H01M		
Documentation searched other than minimum documentation to the extent that such documents are included in the fields searched		
SE,DK,FI,NO classes as above		
Electronic data base consulted during the international search (name of data base and, where practicable, search terms used)		
WPI		
C. DOCUMENTS CONSIDERED TO BE RELEVANT		
Category*	Citation of document, with indication, where appropriate, of the relevant passages	Relevant to claim No.
A	EP 0762592 A2 (ROBERT BOSCH GMBH), 12 March 1997 (12.03.97), column 2, line 5 - column 3, line 7 --	1-63
A	US 5460901 A (SYRJÄLÄ; MARKKU), 24 October 1995 (24.10.95), abstract --	1-63
A	US 5489834 A (PITKANEN), 6 February 1996 (06.02.96), abstract --	1-63
A	US 5200686 A (LEE), 6 April 1993 (06.04.93), column 3, line 27 - column 4, line 66 -- -----	1-63
<input type="checkbox"/> Further documents are listed in the continuation of Box C. <input checked="" type="checkbox"/> See patent family annex.		
* Special categories of cited documents: "A" document defining the general state of the art which is not considered to be of particular relevance "E" earlier document but published on or after the international filing date "L" document which may throw doubts on priority claim(s) or which is cited to establish the publication date of another citation or other special reason (as specified) "O" document referring to an oral disclosure, use, exhibition or other means "P" document published prior to the international filing date but later than the priority date claimed "T" later document published after the international filing date or priority date and not in conflict with the application but cited to understand the principle or theory underlying the invention "X" document of particular relevance: the claimed invention cannot be considered novel or cannot be considered to involve an inventive step when the document is taken alone "Y" document of particular relevance: the claimed invention cannot be considered to involve an inventive step when the document is combined with one or more other such documents, such combination being obvious to a person skilled in the art "&" document member of the same patent family		
Date of the actual completion of the international search		Date of mailing of the international search report
15 February 1999		19 -02- 1999
Name and mailing address of the ISA / Swedish Patent Office Box 5055, S-102 42 STOCKHOLM Facsimile No. +46 8 666 02 86		Authorized officer Håkan Sandh Telephone No. +46 8 782 25 00

INTERNATIONAL SEARCH REPORT
Information on patent family members

02/02/99

International application No.
PCT/SE 98/01942

Patent document cited in search report	Publication date	Patent family member(s)	Publication date
EP 0762592 A2	12/03/97	DE 19532013 A	06/03/97
US 5460901 A	24/10/95	GB 2270983 A,B	30/03/94
US 5489834 A	06/02/96	EP 0572152 A	01/12/93
		FI 90929 B,C	31/12/93
		FI 922386 D	00/00/00
		JP 6094811 A	08/04/94
US 5200686 A	06/04/93	NONE	