

Jan. 6. 1925

1,522,429

A. A. FERLE

FILING DEVICE

Filed April 23, 1924

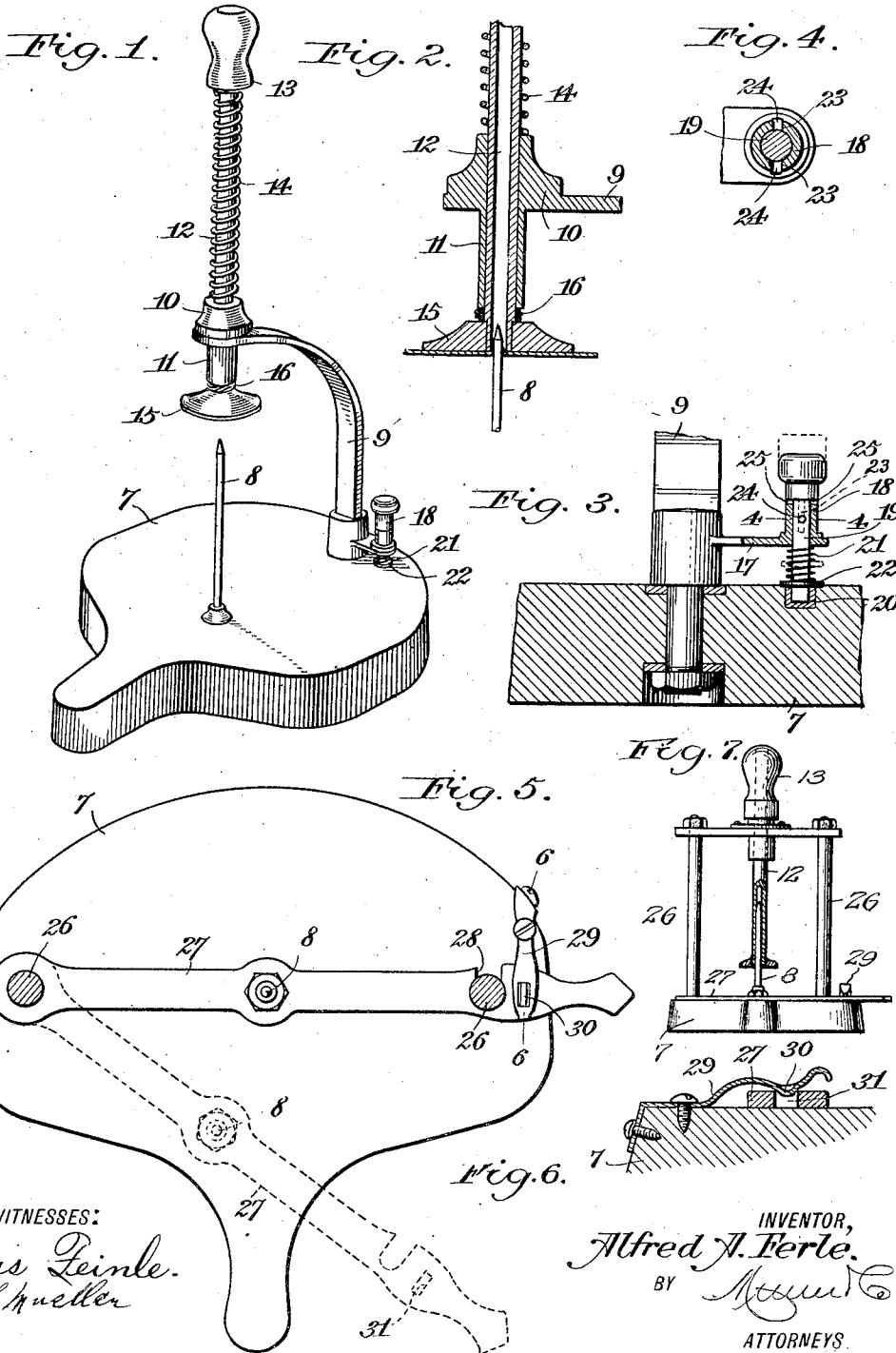

WITNESSES:
Chris Leinle.
E. L. Mueller

INVENTOR,
Alfred A. Ferle.
BY *Attorneys*
ATTORNEYS.

UNITED STATES PATENT OFFICE.

ALFRED A. FERLE, OF NEW YORK, N. Y.

FILING DEVICE.

Application filed April 23, 1924. Serial No. 703,587.

To all whom it may concern:

Be it known that I, ALFRED A. FERLE, a citizen of the United States, and a resident of the city of New York, borough of Manhattan, in the county of New York and State of New York, have invented a new and Improved Filing Device, of which the following is a full, clear, and exact description.

10 This invention relates to improvements in filing devices, and has particular reference to a device for filing papers and the like.

An object of the invention is to provide an improved device of simple and inexpensive construction wherein cooperating means are utilized to facilitate the attachment of papers to the base of the device and wherein one of said means is adjustable relative to the other to permit of ready detachment of the papers from said base.

20 Another object is to accurately position the cooperating means relative to each other and maintain the same in such position so that when said means are operated the papers will always be properly filed upon the base of the device.

25 The above and other objects will appear more clearly from the following detailed description, when taken in connection with the accompanying drawing, which illustrates preferred embodiments of the inventive idea.

In the drawing—

35 Figure 1 is a perspective view of one form of the invention;

Figure 2 is a fragmentary vertical longitudinal section through the cooperating means utilized to file papers upon the base of the device;

40 Figure 3 is a sectional view of the latching means employed for maintaining the cooperating filing means in proper relationship;

45 Figure 4 is a section on the line 4—4 of Figure 3;

Figure 5 is a horizontal sectional view illustrating a different form of the invention;

50 Figure 6 is a section on the line 6—6 of Figure 5; and

Figure 7 is a front elevation, partly broken away and shown in section, of the form of the invention shown in Figure 5.

55 Adjacent the rear edge of the base the same has rotatably mounted therein in any suitable manner the lower end of a support-

ing arm 9, the upper end of which is curved forwardly to a point directly overhanging the rod 8. A boss 10 with a depending sleeve 11 is formed upon the upper end of the arm 9 and these parts provide a bearing in which is slidably mounted the hollow plunger 12, the upper end of which has a handle 13. Interposed between the boss 10 and the handle 13 is a coil spring 14 which normally maintains the plunger in an elevated position and against the tension of which spring said plunger is forced downwardly when filing papers on the rod 8. The lower end of the plunger 12 below the sleeve 11 carries a paper engaging head 15 between which and the lower end of said sleeve there is interposed a small coil spring 16 forming a cushion for the head 15 when the same is forced downwardly into engagement with a pile of papers on the rod 8. Thus when it is desired to file a paper upon the rod 8 the paper is interposed between the upper end of said rod and the head 15 and said plunger 12 is then depressed to force the paper downwardly so that the pointed end of the rod 8 will penetrate said paper and project into the hollow plunger, as shown in Figure 2.

85 In the operation of this device it is essential that when the cooperating means for filing the papers consisting of the rod 8 and the plunger 12 are in operative position the opening through said plunger must be in direct vertical alignment with the rod so that a depression of the plunger will always cause said rod to project into the opening in the plunger and not strike the head 15. To this end the invention provides a latching member carried by the lower end of the supporting arm and consisting of a bracket 17 extending laterally from the arm and having a bushing 18 formed upon its free end. Slidably mounted in said bushing for vertical movement therein is a plunger 19, the lower end of which is engageable in a socket 20 formed in the base 7 when the rod 8 and plunger 12 are in cooperating position. The plunger is yieldably maintained in its operative position by the interposition of a coil spring 21 between the bracket 17 and a flange 22 formed upon the plunger adjacent its lower end and engageable with the base. The bushing 18 is provided with opposed vertical slots 23 into which the pins 24 carried by the plunger project when the plunger is in its operative position. Should

it be desired to rotate the arm 9 with respect to the base 7 and rod 8 in order to swing the plunger out of direct alignment with said rod so as to facilitate the removal of papers from the rod, the plunger 19 is first lifted to withdraw the lower end thereof from the socket 20 and then given a slight rotation to engage the pins 24 in notches 25 formed in the upper end of the bushing 18. When thus engaged the plunger will be maintained in its inoperative position until such time when it is desired to again bring the filing means into cooperative relation, at which time the plunger may again be rotated to engage the pins 24 in the slots 23 and thus enable the spring 21 to force said plunger downwardly into the socket 20.

In the form of the invention shown in Figures 5-7 the base 7 has extending therefrom the standards 26 which are utilized to support the plunger 12 and its cooperating parts above the base, the plunger in this instance being held stationary against any transverse movement relative to the base. In the embodiment now being described, the rod 8 is moved relative to the plunger instead of as in Figure 1 and for this purpose the lower end of said rod is mounted upon the intermediate portion of a swinging arm 27 pivotally mounted upon one of the standards 26 and provided adjacent its opposite end with a notch 28 for receiving the other standard 26 when the rod 8 is in its operative position in direct alignment with the plunger 12. To yieldably maintain the arm 27 in its operative position a spring latch 29 is provided one end of which is secured to the base. The latch 29 extends transversely with respect to the free end of the arm 27 and is formed with a projection 30 engageable in a notch 31 in the arm, which projection snaps into the notch when the arm is moved to the full line position shown in Figure 5. The engagement of the latch with the arm and the standard 26 in the notch 28 will insure the proper alignment of the rod 8 and plunger 12 so that said rod will always project into the plunger when the latter is depressed. When it is desired to remove papers from the rod 8 the free end of the arm 27 may be swung to the dotted line position shown in Figure 5, in which position said papers may be removed from the rod without contacting the head 15.

What is claimed is:

1. A filing device including a base, paper-receiving means extending upwardly from said base, and means suspended above and movable toward said paper-receiving means to attach a paper thereto, one of the last two means being rotatably movable in a

lateral direction with respect to the other and to said said base to permit of the removal of a paper from said receiving means.

2. A filing device including a base, paper-receiving means extending upwardly from said base, means suspended above and movable toward said paper-receiving means to attach a paper thereto, one of the last two means being rotatably movable in a lateral direction with respect to the other and to said base to permit of the removal of a paper from said receiving means, and a latching device for retaining said two means in cooperative relation.

3. A filing device including a base, a rod extending upwardly from said base, and hollow means suspended above said base in direct alignment with said rod and movable relative to said rod to bring it down upon the same and thereby mount a paper on said rod, one of the last two means being rotatable with respect to the other and to said base in a plane parallel with said base.

4. A filing device including a base, a rod extending upwardly from said base, hollow means suspended above said base in direct alignment with said rod and movable relative to said rod to bring it down upon the same and thereby mount a paper on said rod, one of the last two means being rotatable with respect to the other and to said base, in a plane parallel with said base and a latching device for retaining said rod and means in cooperative relation.

5. A filing device including a base, a paper-receiving member mounted upon said base, a supporting arm rotatably mounted upon said base, a plunger carried by said arm and positioned in direct alignment with said receiving member when said elements are in cooperative relation, said plunger being operable to attach a paper to said rod, and a latching device carried by said arm and engageable with said base to retain said rod and plunger in direct alignment with each other.

6. A filing device including a base, a paper-receiving member mounted upon said base, a supporting arm rotatably mounted upon said base, a plunger carried by said arm and positioned in direct alignment with said receiving member when said elements are in cooperative relation, said plunger being operable to attach a paper to said rod, a latching device including a spring-pressed plunger supported by said arm, and means for yieldably maintaining said plunger in engagement with said base to prevent rotation of said arm when said plunger and rod are in alignment with each other.

ALFRED A. FERLE.