



- (51) International Patent Classification:
A61B 18/14 (2006.01) A61M 25/10 (2013.01)
- (21) International Application Number:
PCT/US2014/047654
- (22) International Filing Date:
22 July 2014 (22.07.2014)
- (25) Filing Language: English
- (26) Publication Language: English
- (30) Priority Data:
61/857,067 22 July 2013 (22.07.2013) US
- (71) Applicant: BOSTON SCIENTIFIC SCIMED, INC.
[US/US]; One Scimed Place, Maple Grove, Minnesota 55311 (US).
- (72) Inventors: GROFF, Joel, N.; 300 2nd St. N, Delano, Minnesota 55328 (US). HAVERKOST, Patrick, A.; 6730 Toledo Avenue N, Brooklyn Center, Minnesota 55429 (US). WILLARD, Martin, R.; 1514 Raleigh Drive, Burnsville, Minnesota 55337 (US). CAO, Hong; 17733 62nd Ct N, Maple Grove, Minnesota 55311 (US). HORN, Daniel, J.; 291 Poplar Drive, Shoreview, Minnesota 55126 (US). LARSON, Kenneth, R.; 524 8th Avenue NE, Grand Rapids, Minnesota 55744 (US). CHEN, John, Jianhua; 4725 Terraceview Lane North, Plymouth, Minnesota 55446 (US).

(74) Agent: WICKHEM, J. Scot; Seager, Tuffe & Wickhem, LLC, 1221 Nicollet Avenue, Suite 800, Minneapolis, MN 55403 (US).

(81) Designated States (unless otherwise indicated, for every kind of national protection available): AE, AG, AL, AM, AO, AT, AU, AZ, BA, BB, BG, BH, BN, BR, BW, BY, BZ, CA, CH, CL, CN, CO, CR, CU, CZ, DE, DK, DM, DO, DZ, EC, EE, EG, ES, FI, GB, GD, GE, GH, GM, GT, HN, HR, HU, ID, IL, IN, IR, IS, JP, KE, KG, KN, KP, KR, KZ, LA, LC, LK, LR, LS, LT, LU, LY, MA, MD, ME, MG, MK, MN, MW, MX, MY, MZ, NA, NG, NI, NO, NZ, OM, PA, PE, PG, PH, PL, PT, QA, RO, RS, RU, RW, SA, SC, SD, SE, SG, SK, SL, SM, ST, SV, SY, TH, TJ, TM, TN, TR, TT, TZ, UA, UG, US, UZ, VC, VN, ZA, ZM, ZW.

(84) Designated States (unless otherwise indicated, for every kind of regional protection available): ARIPO (BW, GH, GM, KE, LR, LS, MW, MZ, NA, RW, SD, SL, SZ, TZ, UG, ZM, ZW), Eurasian (AM, AZ, BY, KG, KZ, RU, TJ, TM), European (AL, AT, BE, BG, CH, CY, CZ, DE, DK, EE, ES, FI, FR, GB, GR, HR, HU, IE, IS, IT, LT, LU, LV, MC, MK, MT, NL, NO, PL, PT, RO, RS, SE, SI, SK, SM, TR), OAPI (BF, BJ, CF, CG, CI, CM, GA, GN, GQ, GW, KM, ML, MR, NE, SN, TD, TG).

Published:
— with international search report (Art. 21(3))

WO 2015/013301 A1

(54) Title: RENAL NERVE ABLATION CATHETER HAVING TWIST BALLOON

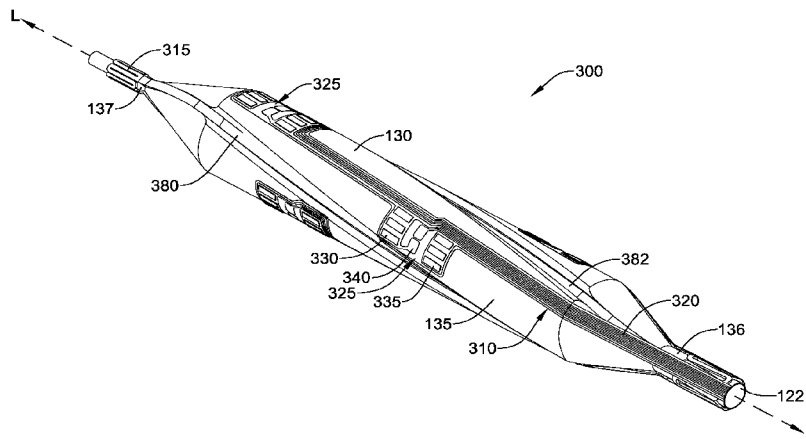

FIG. 7

(57) Abstract: Medical devices and methods for making and using medical devices are disclosed. An example medical device may include a catheter shaft. An expandable balloon may be coupled to the catheter shaft. The balloon may be capable of shifting between a folded configuration and an expanded configuration. A support structure may be coupled to the balloon. The support structure may be capable of shifting the balloon toward the folded configuration. A plurality of elongate flexible electrode assemblies may be disposed on the balloon. The elongate flexible electrode assemblies may be oriented at an angle relative to a longitudinal axis of the balloon.

RENAL NERVE ABLATION CATHETER HAVING TWIST BALLOON

Cross-Reference to Related Applications

5 This application claims priority under 35 U.S.C. §119 to U.S. Provisional Application Serial No. 61/857,067, filed July 22, 2013, the entirety of which is incorporated herein by reference.

Technical Field

10 The present disclosure pertains to medical devices, and methods for manufacturing medical devices. More particularly, the present disclosure pertains to medical devices for renal nerve ablation.

Background

15 A wide variety of intracorporeal medical devices have been developed for medical use, for example, intravascular use. Some of these devices include guidewires, catheters, and the like. These devices are manufactured by any one of a variety of different manufacturing methods and may be used according to any one of a variety of methods. Of the known medical devices and methods, each has certain
20 advantages and disadvantages. There is an ongoing need to provide alternative medical devices as well as alternative methods for manufacturing and using medical devices.

Brief Summary

This disclosure provides design, material, manufacturing method, and use
25 alternatives for medical devices. An example medical device includes a medical device for renal nerve ablation. The medical device may include a catheter shaft. An expandable balloon may be coupled to the catheter shaft. The balloon may be capable of shifting between a folded configuration and an expanded configuration. A support structure may be coupled to the balloon. The support structure may be capable of
30 shifting the balloon toward the folded configuration. A plurality of elongate flexible electrode assemblies may be disposed on the balloon. The elongate flexible electrode assemblies may be oriented at an angle relative to a longitudinal axis of the balloon.

Another example medical device for renal nerve ablation may include a catheter shaft. An expandable balloon may be coupled to the catheter shaft. The

balloon may have a proximal end, a distal end, and a length extending therebetween. A support structure may be coupled to the balloon. The support structure may be capable of causing the balloon to fold in a pre-determined manner upon retraction of the balloon into a guide catheter. A plurality of flexible electrode assemblies may be
5 coupled to the support structure.

An example method for ablating renal nerves is also disclosed. The method may include providing a medical device. The medical device may include a catheter shaft. An expandable balloon may be coupled to the catheter shaft. The balloon may be capable of shifting between a folded configuration and an expanded configuration.
10 A support structure may be coupled to the balloon. The support structure may be capable of shifting the balloon toward the folded configuration. A plurality of elongate flexible electrode assemblies may be disposed on the balloon. The elongate flexible electrode assemblies may be oriented at an angle relative to a longitudinal axis of the balloon. The method may also include advancing the medical device
15 through a guide catheter and into a blood vessel to a position within a renal artery, expanding the balloon, activating at least some of the elongate flexible electrode assemblies, and retracting the balloon into the guide catheter. The interaction between the support structure and the guide catheter shifts the balloon to the folded configuration.

20 The above summary of some embodiments is not intended to describe each disclosed embodiment or every implementation of the present disclosure. The Figures, and Detailed Description, which follow, more particularly exemplify these embodiments.

Brief Description of the Drawings

25 The disclosure may be more completely understood in consideration of the following detailed description in connection with the accompanying drawings, in which:

FIG. 1 is a schematic view of an example renal nerve ablation device;

FIG. 2 is a perspective view of an example expandable member of a renal
30 nerve ablation device;

FIG. 3 is a partial top view of the expandable member of Figure 2 in an unrolled or flat configuration;

FIG. 4 is a top view of a portion of an example electrode assembly;

FIG. 5 is a partial cross-sectional view A-A of Figure 4;

FIG. 6 is a partial cross-sectional view B-B of Figure 4;

FIG. 7 is a side elevation view of an example expandable member of a renal nerve ablation device;

FIG. 8 is a perspective view of an example expandable member;

5 FIG. 9 is a perspective view of an example support structure;

FIG. 10 is a perspective view of the expandable member of FIG. 8 with the support structure of FIG. 9;

FIG. 11 is a side view of an example expandable member of a renal nerve ablation device;

10 FIG. 12A is a partial top view of the expandable member of FIG. 11 in an unrolled or flat configuration;

FIG. 12B is a partial top view of an alternative expandable member in an unrolled or flat configuration;

15 FIG. 12C is a partial top view of an alternative expandable member in an unrolled or flat configuration; and

FIG. 12D is a partial top view of an alternative expandable member in an unrolled or flat configuration.

20 While the disclosure is amenable to various modifications and alternative forms, specifics thereof have been shown by way of example in the drawings and will be described in detail. It should be understood, however, that the intention is not to limit the invention to the particular embodiments described. On the contrary, the intention is to cover all modifications, equivalents, and alternatives falling within the spirit and scope of the disclosure.

25 Detailed Description

The following description should be read with reference to the drawings, which are not necessarily to scale, wherein like reference numerals indicate like elements throughout the several views. The detailed description and drawings are intended to illustrate but not limit the claimed invention. Those skilled in the art will
30 recognize that the various elements described and/or shown may be arranged in various combinations and configurations without departing from the scope of the disclosure. The detailed description and drawings illustrate example embodiments of the claimed invention.

For the following defined terms, these definitions shall be applied, unless a different definition is given in the claims or elsewhere in this specification.

All numeric values are herein assumed to be modified by the term “about,” whether or not explicitly indicated. The term “about”, in the context of numeric values, generally refers to a range of numbers that one of skill in the art would consider equivalent to the recited value (i.e., having the same function or result). In many instances, the term “about” may include numbers that are rounded to the nearest significant figure. Other uses of the term “about” (i.e., in a context other than numeric values) may be assumed to have their ordinary and customary definition(s), as understood from and consistent with the context of the specification, unless otherwise specified.

The recitation of numerical ranges by endpoints includes all numbers within that range, including the endpoints (e.g. 1 to 5 includes 1, 1.5, 2, 2.75, 3, 3.80, 4, and 5).

As used in this specification and the appended claims, the singular forms “a”, “an”, and “the” include plural referents unless the content clearly dictates otherwise. As used in this specification and the appended claims, the term “or” is generally employed in its sense including “and/or” unless the content clearly dictates otherwise.

It is noted that references in the specification to “an embodiment”, “some embodiments”, “other embodiments”, etc., indicate that the embodiment(s) described may include a particular feature, structure, or characteristic, but every embodiment may not necessarily include the particular feature, structure, or characteristic. Moreover, such phrases are not necessarily referring to the same embodiment. Further, when a particular feature, structure, or characteristic is described in connection with an embodiment, it would be within the knowledge of one skilled in the art to effect such feature, structure, or characteristic in connection with other embodiments, whether or not explicitly described, unless clearly stated to the contrary. That is, the various individual elements described below, even if not explicitly shown in a particular combination, are nevertheless contemplated as being combinable or arrangeable with each other to form other additional embodiments or to complement and/or enrich the described embodiment(s), as would be understood by one of ordinary skill in the art.

Certain treatments are aimed at the temporary or permanent interruption or modification of select nerve function. One example treatment is renal nerve ablation,

which is sometimes used to treat conditions such as or related to hypertension, congestive heart failure, diabetes, or other conditions impacted by high blood pressure or salt retention. The kidneys produce a sympathetic response, which may increase the undesired retention of water and/or sodium. The result of the sympathetic
5 response, for example, may be an increase in blood pressure. Ablating some of the nerves running to the kidneys (e.g., disposed adjacent to or otherwise along the renal arteries) may reduce or eliminate this sympathetic response, which may provide a corresponding reduction in the associated undesired symptoms (e.g., a reduction in blood pressure).

10 Some embodiments of the present disclosure relate to a power generating and control apparatus, often for the treatment of targeted tissue in order to achieve a therapeutic effect. In some embodiments, the target tissue is tissue containing or proximate to nerves, including renal arteries and associated renal nerves. In other embodiments the target tissue is luminal tissue, which may further comprise diseased
15 tissue such as that found in arterial disease.

In some embodiments of the present disclosure, the ability to deliver energy in a targeted dosage may be used for nerve tissue in order to achieve beneficial biologic responses. For example, chronic pain, urologic dysfunction, hypertension, and a wide variety of other persistent conditions are known to be affected through the operation
20 of nervous tissue. For example, it is known that chronic hypertension that may not be responsive to medication may be improved or eliminated by disabling excessive nerve activity proximate to the renal arteries. It is also known that nervous tissue does not naturally possess regenerative characteristics. Therefore it may be possible to beneficially affect excessive nerve activity by disrupting the conductive pathway of
25 the nervous tissue. When disrupting nerve conductive pathways, it is particularly advantageous to avoid damage to neighboring nerves or organ tissue. The ability to direct and control energy dosage is well-suited to the treatment of nerve tissue. Whether in a heating or ablating energy dosage, the precise control of energy delivery as described and disclosed herein may be directed to the nerve tissue. Moreover,
30 directed application of energy may suffice to target a nerve without the need to be in exact contact, as would be required when using a typical ablation probe. For example, eccentric heating may be applied at a temperature high enough to denature nerve tissue without causing ablation and without requiring the piercing of luminal tissue. However, it may also be desirable to configure the energy delivery surface of

the present disclosure to pierce tissue and deliver ablating energy similar to an ablation probe with the exact energy dosage being controlled by a power control and generation apparatus.

Electrical energy dissipation may rely on electrode impedance or on the
5 impedance of the electrode-tissue interface rather than dissipation from the impedance of tissue between active and ground electrodes. Illustratively, whereas typical RF ablation therapies may use medical devices with conductive electrodes, the disclosed concept may include resistive flexible electrode assemblies including one or more of resistive electrodes, a resistive material coated on conductive electrodes,
10 microheaters, and/or other resistors. The use of resistive flexible electrode assemblies, may allow for low voltage ablation devices, where the electrical energy may be provided via direct current or alternating current (e.g., low voltage direct current, low frequency (less than 200 KHz) alternating current, or other energy).

In some embodiments, efficacy of the denervation treatment can be assessed
15 by measurement before, during, and/or after the treatment to tailor one or more parameters of the treatment to the particular patient or to identify the need for additional treatments. For instance, a denervation system may include functionality for assessing whether a treatment has caused or is causing a reduction in neural activity in a target or proximate tissue, which may provide feedback for adjusting
20 parameters of the treatment or indicate the necessity for additional treatments.

While the devices and methods described herein are discussed relative to renal nerve ablation and/or modulation, it is contemplated that the devices and methods may be used in other treatment locations and/or applications where nerve modulation and/or other tissue modulation including heating, activation, blocking, disrupting, or
25 ablation are desired, such as, but not limited to: blood vessels, urinary vessels, or in other tissues via trocar and cannula access. For example, the devices and methods described herein can be applied to hyperplastic tissue ablation, cardiac ablation, pulmonary vein isolation, pulmonary vein ablation, tumor ablation, benign prostatic hyperplasia therapy, nerve excitation or blocking or ablation, modulation of muscle
30 activity, hyperthermia or other warming of tissues, etc.

Figure 1 is a schematic view of an example renal nerve ablation system 100. System 100 may include a renal nerve ablation device 120. Renal nerve ablation device 120 may be used to ablate nerves (e.g., renal nerves) disposed adjacent to the kidney K (e.g., renal nerves disposed about a renal artery RA). In use, renal nerve

ablation device 120 may be advanced through a blood vessel such as the aorta A to a position within the renal artery RA. This may include advancing renal nerve ablation device 120 through a guide sheath or catheter 14. When positioned as desired, renal nerve ablation device 120 may be activated to activate one or more electrodes (not shown). This may include operatively coupling renal nerve ablation device 120 to a control unit 110, which may include an RF generator, so as to supply the desired activation energy to the electrodes. For example, renal nerve ablation device 120 may include a wire or conductive member 18 with a connector 20 that can be connected to a connector 22 on the control unit 110 and/or a wire 24 coupled to the control unit 110. In at least some embodiments, the control unit 110 may also be utilized to supply/receive the appropriate electrical energy and/or signal to activate one or more sensors disposed at or near a distal end of renal nerve ablation device 120. When suitably activated, the electrodes may be capable of ablating tissue (e.g., renal nerves) as described below and the sensors may be used to detect desired physical and/or biological parameters.

In some embodiments, the renal nerve ablation device 120 may include an elongate tubular member or catheter shaft 122, as shown in FIG. 2. In some embodiments, the elongate tubular member or catheter shaft 122 may be configured to be slidably advanced over a guidewire or other elongate medical device to a target site. In some embodiments, the elongate tubular member or catheter shaft 122 may be configured to be slidably advanced within a guide sheath or catheter 14 to a target site. In some embodiments, the elongate tubular member or catheter shaft 122 may be configured to be advanced to a target site over a guidewire, within a guide sheath or catheter 14, or a combination thereof. An expandable member 130 may be disposed at, on, about, or near a distal region of the elongate tubular member or catheter shaft 122.

For example, as shown in FIG. 2, in some embodiments, the electrode assemblies may be arranged on the expandable member 130, shown here in an expanded state, according to a plurality of generally cylindrical treatment zones A-D. In other embodiments, the expandable member 130 or other components of the treatment system may include additional electrode assemblies that are not in a treatment zone or are otherwise not used or configured to deliver a treatment energy.

The treatment zones A-D and associated electrode assemblies 140a-d are further illustrated in FIG. 3, which is an “unrolled” depiction of a portion of the

expandable member 130 of FIG. 2. The treatment zones A-D may be longitudinally adjacent to one another along longitudinal axis L-L, and may be configured such that energy applied by the electrode assemblies create treatments that do not overlap. Treatments applied by the longitudinally adjacent bipolar electrode assemblies 140a-d
5 may be circumferentially non-continuous along longitudinal axis L-L. For example, with reference to FIG. 3, lesions created in treatment zone A may in some embodiments minimize overlap about a circumference (laterally with respect to L-L in this view) with lesions created in treatment zone B. In other embodiments, however, the energy applied by the electrode assemblies, such as the electrode assemblies
10 shown in FIG. 3, may overlap, longitudinally, circumferentially, and/or in other ways, to at least some extent. Each electrode pad assembly may include four elements, which are a distal electrode pad 150a-d, intermediate tail 160a-d, proximal electrode pad 170a-d, and proximal tail 180b,d (not shown for electrode pad assemblies 140b and 140c).

15 FIG. 4 shows a top view of electrode assembly 200, which is identified in FIG. 3 as electrode assembly 140. The electrode assembly 200 may be constructed as a flexible circuit having a plurality of layers. Such layers may be continuous or non-contiguous, i.e., made up of discrete portions. Shown in FIGS. 5 and 6, a base layer 202 of insulation may provide a foundation for the electrode assembly 200. The base layer 202 may be constructed from a flexible polymer such as polyimide, although
20 other materials are contemplated. A conductive layer 204 made up of a plurality of discrete traces may be layered on top of the base layer 202. The conductive layer 204 may be, for example, a layer of electrodeposited copper. Other materials are also contemplated. An insulating layer 206 may be discretely or continuously layered on
25 top of the conductive layer 204, such that the conductive layer 204 may be fluidly sealed between the base layer 202 and the insulating layer 206. Like the base layer 202, the insulating layer 206 may be constructed from a flexible polymer such as polyimide, although other materials are contemplated. In some embodiments, the insulating layer 206 may be from about 0.01 mm thick to about 0.02 mm thick. In
30 other embodiments, the insulating layer 206 may be a complete or partial polymer coating, such as PTFE or silicone. Other materials are also contemplated.

The electrode assembly 200 shown in FIG. 4 may include a distal electrode pad 208. In this region, the base layer 202 may form a rectangular shape. This is not intended to be limiting. Other shapes are contemplated. As shown, the electrode

assembly 200 may include a plurality of openings to provide for added flexibility, and the pads and other portions of the assemblies may include rounded or curved corners, transitions and other portions. In some instances, the openings and rounded / curved features may enhance the assembly's resistance to delamination from its expandable device, as may occur, in some instances, when the expandable device is repeatedly expanded and collapsed (which may also entail deployment from and withdrawal into a protective sheath), such as may be needed when multiple sites are treated during a procedure.

The distal electrode pad 208 may include a plurality of discrete traces layered on top of the base layer 202. These traces may include a ground trace 210, an active electrode trace 212, and a sensor trace 214. The ground trace 210 may include an elongated electrode support 216 laterally offset from a sensor ground pad 218. The sensor ground pad 218 may be electrically coupled to the elongated electrode support 216 of the ground trace 210 and may be centrally located on the distal electrode pad 208. A bridge 220 may connect a distal most portion of the sensor ground pad 218 to a distal portion of the elongated electrode support 216 of the ground trace 210. The bridge 220 may taper down in width as it travels to the sensor ground pad 218. In some embodiments, the bridge 220 may have a relatively uniform and thin width to enable a desired amount of flexibility. The elongated electrode support 216 may taper down in width at its proximal end, however, this is not required. In some embodiments, the elongated electrode support 216 may abruptly transition to a much thinner trace at its proximal portion, to enable a desired amount of flexibility. Generally, the curvature of the traces where necking is shown may be optimized to reduce balloon recapture forces and the potential for any snagging that sharper contours may present. The shape and position of the traces may also be optimized to provide dimensional stability to the electrode assembly 200 as a whole, so as to prevent distortion during deployment and use.

FIG. 5 shows a partial cross-section A-A of the distal electrode pad 208. An electrode 222 is shown layered over a portion of the insulating layer 206, which may have a plurality of passages (e.g., holes) to enable the electrode 222 to couple to the elongated electrode support 216 of the ground trace 210 (of conductive layer 204).

As shown in FIG. 4, the ground electrode trace 210 and active electrode trace 212 may include a plurality of electrodes. Three electrodes 222 may be provided for each electrode trace, however, more or less may be used. Additionally, each electrode

222 may have radiused corners to reduce tendency to snag on other devices and/or tissue. Although the above description of the electrodes 222 and the traces associated with them has been described in the context of a bi-polar electrode assembly, those of skill in the art will recognize that the same electrode assembly may function in a monopolar mode as well. For instance, as one non-limiting example, the electrodes associated with active electrode traces 212 and 242 may be used as monopolar electrodes, with ground trace 210 disconnected during energization of those electrodes.

The sensor trace 214 may be centrally located on the distal electrode pad 208 and may include a sensor power pad 224 facing the sensor ground pad 218. These pads may connect to power and ground poles of a temperature sensor 226, such as a thermocouple (for example, Type T configuration: Copper/Constantan) or thermistor, as shown in the partial cross-section depicted in FIG. 6.

The sensor trace 214 may be centrally located on the distal electrode pad 208 and may include a sensor power pad 224 facing the sensor ground pad 218. These pads may connect to power and ground poles of a temperature sensor 226, such as a thermocouple (for example, Type T configuration: Copper/Constantan) or thermistor, as shown in the partial cross-section depicted in FIG. 6.

The temperature sensor 226 may be proximately connected to the sensor power pad 224 and may be distally connected to the sensor ground pad 218. To help reduce overall thickness, the temperature sensor 226 may be positioned within an opening within the base layer 202. In some embodiments, the temperature sensor 226 may be a thermistor. As shown, the temperature sensor 226 may be on a non-tissue contacting side of the distal electrode pad 208. Accordingly, the temperature sensor 226 may be captured between the electrode structure and a balloon when incorporated into a final device, such as ablation device 120. This may be advantageous since surface-mounted electrical components, like thermistors, typically have sharp edges and corners, which may get caught on tissue and possibly cause problems in balloon deployment and/or retraction. This arrangement may also keep soldered connections from making contact with blood, since solder is typically non-biocompatible. Further, due to the placement of the temperature sensor, it may measure temperature representative of tissue and the electrodes 222.

From the distal electrode pad 208, the combined base layer 202, conductive layer 204, and insulating layer 206 may reduce in lateral width to an intermediate tail

228. Here, the conductive layer 204 may be formed to include an intermediate ground line 230, intermediate active electrode line 232, and intermediate sensor line 234, which may be respectively coextensive traces of the ground trace 210, active electrode trace 212, and sensor trace 214 of the distal electrode pad 208.

5 From the intermediate tail 228, the combined base layer 202, conductive layer 204, and insulating layer 206 may increase in lateral width to form a proximal electrode pad 236. The proximal electrode pad 236 may be constructed similarly to the distal electrode pad 208, with the electrode geometry and temperature sensor arrangement being essentially identical, although various differences may be present.
10 However, as shown, the proximal electrode pad 236 may be laterally offset from the distal electrode pad 208 with respect to a central axis G-G extending along the intermediate ground line 230. The intermediate active electrode line 232 and intermediate sensor line 234 may be laterally coextensive with the proximal electrode pad 236 on parallel respective axes with respect to central axis G-G.

15 From the proximal electrode pad 236, the combined base layer 202, conductive layer 204, and insulating layer 206 may reduce in lateral width to form a proximal tail 238. The proximal tail 238 may include a proximal ground line 240, proximal active electrode line 242, and proximal sensor line 244, as well the intermediate active electrode line 232 and intermediate sensor line 234. The proximal
20 tail 238 may include connectors (not shown) to enable coupling to one or more sub-wiring harnesses and/or connectors and ultimately to control unit 110. Each of these lines may be extended along parallel respective axes with respect to central axis G-G.

As shown, the electrode assembly 200 may have an asymmetric arrangement of the distal electrode pad 208 and proximal electrode pad 236, about axis G-G.
25 Further, the ground electrodes of both electrode pads may be substantially aligned along axis G-G, along with the intermediate and proximal ground lines 230/240. It has been found that this arrangement may present certain advantages. For example, by essentially sharing the same ground trace, the width of the proximal tail may be only about one and a half times that of the intermediate tail 228, rather than being
30 approximately twice as wide if each electrode pad had independent ground lines. Thus, the proximal tail 238 may be narrower than two of the intermediate tails 228.

The system 100 may be used to perform a method of treatment in accordance with one non-limiting embodiment of the disclosure. For example, the control unit 110 may be operationally coupled to the ablation device 120, which may be inserted

into a body passageway such that an expandable member 130 (having a plurality of electrode assemblies) may be placed adjacent to a first section of the body passageway where therapy is required. Placement of the ablation device 120 at the first section of the body passageway where therapy is required may be performed according to conventional methods, e.g., over a guidewire under fluoroscopic guidance. Once inserted, the expandable member 130 may be made to expand from a collapsed delivery configuration to an expanded configuration, for example by pressurizing fluid from about 2-10 atm in the case of a balloon. This may cause the electrodes and/or electrode assemblies of the expandable member 130 to come into contact with the first section of the body passageway.

The use of medical devices that include a balloon with a flex circuit coupled thereto, for example as described herein, may be desirable. In some instances, however, the flex circuits may include relatively stiff materials. Accordingly, if the balloon is deflated, the flex circuit may tend to flatten and/or widen out. When so configured, the flex circuit, or edges thereof, could catch on the edge of a guide catheter when proximally retracting the medical device (e.g., including the flex circuit) into the guide catheter. Disclosed herein are medical devices that include structural features that may reduce the likelihood of a flex circuit or other structures of the medical device “catching” on the end of a guide catheter (or other device) when being retracted, for example, into the guide catheter.

Turning now to FIG. 7, a renal nerve ablation device 300 may include an expandable member 130 that may be disposed at, on, about, or near a distal region of the elongate tubular member or catheter shaft 122, as discussed above. In at least some embodiments, expandable member 130 takes the form of a balloon. In some embodiments, the proximal waist 136 of the balloon 130 may be attached to the elongate tubular member or catheter shaft 122.

In some embodiments, the renal nerve ablation device 300 includes one or more flexible elongate members 310. The flexible elongate members 310 may be similar in form and function to the electrode assemblies and/or flex circuits disclosed herein (e.g., electrode assembly 200). In at least some embodiments, the flexible elongate members 310 may be attached to the expandable member 130. In some embodiments, each elongate member 310 may contain one or more electrode assemblies 325. In some embodiments, each electrode assembly 325 may include one or more ground electrodes 330, one or more active electrodes 335, and a temperature

sensor 340. In some embodiments, each elongate member 310 may have electrode assemblies 325 that extend from alternating sides, as shown in FIGS. 7 and 12A-12D. In some embodiments, the electrodes and sensors of each electrode assembly 325 may be arranged as shown in FIG. 4.

5 Balloon 130 may be expandable or otherwise inflatable. Balloon 130 may also be capable of deflating. The general, the form or profile of balloon 130 may be reduced when expandable member 130 is deflated. However, in instances where elongate members 310 and/or electrode assemblies 325 includes relatively stiff materials, elongate members 310 and/or electrode assemblies 325 may have a
10 tendency to cause balloon 130 to widen when deflated. This widening could lead to elongate members 310 and/or electrode assemblies 325 catching on the end of a guide catheter when retracting balloon 130 into the guide catheter.

The ablation device 300 may also include a support structure 380. In general, support structure 380 is capable of shifting the balloon 130 toward the folded
15 configuration. In at least some embodiments, support structure 380 may include a plurality of support elements 382. For example, as shown in FIG. 7, support elements 382 may take the form of support tines that extend along expandable member 130. Support elements 382 may be positioned between adjacent elongate members 310. Thus, in at least some embodiments, support elements 382 and elongate members 310
20 may alternate circumferentially about balloon 130. In some embodiments, support elements 382 are joined at their distal ends 315 and/or their proximal ends. However, this is not required as embodiments are contemplated where support elements 382 are merely tines extending along balloon 130.

In at least some embodiments, support elements 382 may be capable of or
25 otherwise configured to aid in shifting balloon 130 toward a folded configuration. For example, support elements 382 may form or otherwise define regions along balloon 130 where folding may occur. This may cause balloon 130 to begin to fold upon deflation or otherwise aid in the folding of balloon 130. Furthermore, when balloon 130 is deflated and then retracted into, for example, a guide catheter, support elements
30 382 may engage the distal end of the guide catheter. As further retraction forces are applied to device 300 (to retract balloon 130 into the guide catheter), the interaction between support elements 382 and the guide catheter may cause balloon 130 to rotate. For example, because support elements 382 may be angled along balloon 130, the proximal retraction of device 300 into the guide catheter will have a tendency to cause

balloon 130 to rotate as it enters the guide catheter. The rotation may help to further reduce the profile of balloon 130 or otherwise aid in refolding.

In some of these and in other embodiments, device 300 may include other features that may aid in the folding of balloon 130. For example, portions or all of
5 catheter shaft 122 may include torque-transmitting structures. Such structures may include solid tubes, support structures (e.g., braids, etc.), high-torque sleeves (e.g., tubular members with slots formed therein), or the like.

In some embodiments, a plurality of elongate members 310 may be twisted or
10 canted at an angle from the longitudinal axis L-L of the elongate member 310, as shown in FIGS. 7 and 11-12D. The angled elongate members 310 may be disposed along or otherwise define pre-determined fold lines along which the expandable member 130 may fold after deflation. In some embodiments, angled elongate members 310 aid in twisting and re-folding of the expandable member 130.

The electrode assemblies 325 on adjacent elongate members 310 may be
15 offset, as illustrated in FIG. 7. In other embodiments, the electrode assemblies 325 may have a helical orientation along the length of the expandable member 130 that forms at least one complete (360 degree) circumferential loop within the lumen or vessel that the expandable member 130 is positioned. The electrode assemblies 325 may provide heating at a location within the tissue surrounding the body passageway
20 without damaging the wall of the body passageway in order to disrupt the nerves located in the tissue surrounding the body passageway wall. A helical orientation is desirable to help avoid an increased risk of stenosis that may be present when electrodes are disposed within a single plane normal to a longitudinal axis of the body passageway (i.e., a circular electrode or group of electrodes).

In some embodiments, the expandable member 130 has one or more channels
25 134 extending along a length of the expandable member 130 as shown FIG. 8. The channels 134 are configured to remain when the expandable member 130 is expanded. When the expandable member 130 is placed within a body lumen such as a blood vessel, and expanded, the channels may 134 allow partial fluid flow across the
30 expandable member 130. The channels 134 may be helically arranged about the expandable member 130. In the illustrated embodiments, the expandable member 130 has three channels 134 extending helically along the expandable member 130. This is not intended to be limiting. Any number of channels 134 may be included in the expandable member 130 including one, two, three, four, five, six, or more. The

channels 134 may be spaced apart in a manner that allows for the flexible elongate members 310 to be disposed between channels 134. In some embodiments, the elongate members 310 extend helically at a matching the angle of the channels 134. The channels 134 may provide pre-determined fold lines along which the expandable member 130 folds after deflation. In some embodiments, angled channels 134 aid in twisting and re-folding of the expandable member 130. In some embodiments, the flexible elongate members 310 are mounted within the channels 134. The width of the channels 134 may be adjusted to accommodate the elongate members 310 and the electrode assemblies 325. In some embodiments, channels 134 may be open/unfilled and remain open/unfilled during use. In other embodiments, support elements 382 may be disposed within channels 134.

As shown in FIG. 9, the renal nerve ablation device 300 may include a support structure 380. The support structure 380 may include a plurality of support elements 382. In some embodiments, the support elements 382 may be connected to each other at their proximal ends 384 and at their distal ends 386. In some embodiments, the support elements 382 may be connected to a connection member or ring (not shown). In some embodiments, the distal ends 386 of the support elements 382 may be attached to the distal waist 137 of the expandable member 130 and the proximal ends 384 of the support elements 382 may be attached to proximal waist 136 of the expandable member 130. In other embodiments, the distal 386 and proximal 384 ends of the support elements 382 may be attached to the catheter shaft 122. The distal ends 386 may be connected to each other, but remain free of attachment to the catheter shaft 122 and the expandable member 130. The distal ends 386 may be slidingly disposed around the distal waist 137 of the expandable member 130.

In some embodiments, the support elements 382 may extend substantially parallel to the longitudinal axis of the expandable member 130. In some embodiments, the support elements 382 may extend along the body 135 of the expandable member at an angle to the longitudinal axis. See FIGS. 9-10. In embodiments where the expandable member 130 has channels 134, the support elements 382 may be disposed in the channels. See FIG. 10. In some embodiments, the support structure 380 may be made of a nickel titanium alloy such as nitinol. In other embodiments, the support structure 380 may be made of a polymer.

In some embodiments, the expandable member 130 is a molded balloon, and the support structure 380 may be integrated into the balloon during manufacturing.

For example, the support structure 380 may be inserted into a balloon mold, balloon tubing may be inserted into the support element in the mold. The balloon may then be blown out using conventional processes, integrating the support structure 380 and expandable member 130 into a single enhanced balloon component. In some
5 embodiments, the support structure 380 may be attached to the expandable member 130 after the expandable member 130 is formed.

The support structure 380 may provide enhanced deflation and re-folding characteristics to the expandable member 130. When the expandable member 130 is deflated and/or withdrawn into a guide catheter 14, the support structure 380 may
10 provide pre-determined lines along which the expandable member 130 re-folds. The support structure 380 may allow the expandable member 130 to re-fold in a pre-determined manner and may allow for consistent and complete re-folding of the expandable member 130. The support structure 380 may assist in re-folding the expandable member 130 in a manner that avoids or reduces delamination of the
15 elongate members 310. The pre-determined folding and lack of delamination may allow withdrawal of the device 300 into a guide catheter 14 for re-deployment at a second location. In some embodiments, the flexible elongate members 310 may be mounted on the support elements 382.

In some embodiments, the support structure 380 may be electrically
20 conductive. In some embodiments, the support elements 382 may be separated and function as electrodes, with some support elements being positive and some being negative. In such embodiments, the electrode assemblies 325 may be replaced with conductive support elements 382. For example, electrode assemblies 325 may be electrically coupled to support elements 382. This may allow for fewer components
25 to be utilized in the manufacturing of device 300. In still other embodiments, electrode assemblies 325 may be mounted directly within channels 134 of balloon 130. These are just examples. Other embodiments are contemplated.

Turning now to FIGS. 11-12D, flexible elongate members 310-310h may be attached to the body of the expandable member 130 in a variety of orientations
30 relative to the longitudinal axis L-L. FIG. 11 shows an example set of angled elongate members 310a-310c on an expandable member 130. FIG. 12A shows the expandable member 130 of FIG. 11 in a flat, unrolled configuration. In some embodiments, one or more of the elongate members 310a-310c may have a bend 322 where they transition from parallel to the longitudinal axis L-L at proximal region 320, to an

angled orientation 310a, 310b, 310c. In some embodiments, each of the angled elongate members 310a-310c may have a different length of proximal region 320. In some embodiments, two or more electrode assemblies 325 may extend transverse to the elongate member 310 on opposite sides. For example, FIGS. 12A and 12B show a group of angled elongate members 310a-310f each having two electrode assemblies 325, where the electrode assemblies 325 extend in opposite directions from the elongate member 310a-310f. In some embodiments, such as that shown in FIG. 12C, one or more elongate member 310 may be substantially linear along its length, extending at an angle from the longitudinal axis along its entire length. In some embodiments, an expandable member 130 may have a mixture of substantially linear elongate members 310 and angled elongate members 310g, 310h. In some embodiments, such as that shown in FIGS. 7 and 12D, all of the elongate members 310 may be substantially linear along their length, extending at an angle from the longitudinal axis along the entire length of the expandable member 130.

The angled elongate members 310a-310h may cause the balloon to rotate and fold along the lines of the angled elongate members 310a-310h, reducing the withdrawal force needed to withdraw the ablation device 300 into a guide sheath or catheter 14, and allowing the use of a smaller diameter guide sheath. For example, a 6Fr guide catheter 14 may be used, providing advantages in renal procedures, rather than 8Fr guide catheters which have been previously used. The angled elongate members 310a-310h may reduce shear force, thereby reducing delamination of the elongate members from the expandable member 130. In some embodiments, a transition between the elongate member 310a-310f and a proximal edge 336 of the electrode assembly 325 is gradual, as shown in FIGS. 11, 12A and 8B. A gradual transition may reduce the chance of the proximal edge 336 being caught on the guide catheter 14, and causing delamination, as the ablation device 300 is withdrawn into the guide catheter 14.

In some embodiments, the renal nerve ablation device 300 may include a bipolar electrode pair. When the renal nerve ablation device 300 is energized, such as in the manner(s) described above, RF energy or other suitable energy may pass from the active electrode 335, through the vessel wall and the target tissue (e.g., renal nerves), to the ground electrode 330 thereby creating a corresponding lesion or lesions along a body passageway within which the expandable member 130 has been positioned. The sensor element 340 may be positioned between the ground electrode

330 and the active electrode 335. The sensor element 340 may include at least one temperature sensor, such as a thermistor or thermocouple, positioned on the outer surface of the expandable member 130. The at least one temperature sensor 340 may be positioned between the ground electrode 330 and the active electrode 335, and may
5 be configured to monitor the temperature of the target tissue, the active and ground electrodes, or both, as discussed above. In some embodiments, the at least one temperature sensor 340 may include a plurality of temperature sensors configured to monitor the temperature of the target tissue, the active electrodes, the ground electrodes, or any combination thereof, at a plurality of locations along the length of
10 the expandable member 130.

In use, the ablation device 300 may be advanced through a blood vessel to a position adjacent to a target tissue (e.g., within a renal artery). In some embodiments, the target tissue may be one or more renal nerves disposed about the renal artery. When suitably positioned, expandable member 130 may be expanded from a
15 collapsed delivery configuration to an expanded configuration. This may place the active electrodes 335 against the wall of the blood vessel. The active electrodes 335 may be activated. Ablation energy may be transmitted from the active electrodes 335 through the target tissue (where renal nerves may be ablated, modulated, or otherwise impacted), and back through the ground electrodes 330, in a bipolar configuration, or
20 back through the common ground electrode, in a monopolar configuration.

The materials that can be used for the various components of the ablation device 300 (and/or other devices disclosed herein) may include those commonly associated with medical devices. For simplicity purposes, the following discussion makes reference to the ablation device 300. However, this is not intended to limit the
25 devices and methods described herein, as the discussion may be applied to other similar tubular members and/or expandable members and/or components of tubular members and/or expandable members disclosed herein.

The ablation device 300 and the various components thereof may be made from a metal, metal alloy, polymer (some examples of which are disclosed below), a
30 metal-polymer composite, ceramics, combinations thereof, and the like, or other suitable material. Some examples of suitable polymers may include polytetrafluoroethylene (PTFE), ethylene tetrafluoroethylene (ETFE), fluorinated ethylene propylene (FEP), polyoxymethylene (POM, for example, DELRIN® available from DuPont), polyether block ester, polyurethane (for example,

Polyurethane 85A), polypropylene (PP), polyvinylchloride (PVC), polyether-ester (for example, ARNITEL® available from DSM Engineering Plastics), ether or ester based copolymers (for example, butylene/poly(alkylene ether) phthalate and/or other polyester elastomers such as HYTREL® available from DuPont), polyamide (for example, DURETHAN® available from Bayer or CRISTAMID® available from Elf Atochem), elastomeric polyamides, block polyamide/ethers, polyether block amide (PEBA, for example available under the trade name PEBAX®), ethylene vinyl acetate copolymers (EVA), silicones, polyethylene (PE), Marlex high-density polyethylene, Marlex low-density polyethylene, linear low density polyethylene (for example REXELL®), polyester, polybutylene terephthalate (PBT), polyethylene terephthalate (PET), polytrimethylene terephthalate, polyethylene naphthalate (PEN), polyetheretherketone (PEEK), polyimide (PI), polyetherimide (PEI), polyphenylene sulfide (PPS), polyphenylene oxide (PPO), poly paraphenylene terephthalamide (for example, KEVLAR®), polysulfone, nylon, nylon-12 (such as GRILAMID® available from EMS American Grilon), perfluoro(propyl vinyl ether) (PFA), ethylene vinyl alcohol, polyolefin, polystyrene, epoxy, polyvinylidene chloride (PVdC), poly(styrene-*b*-isobutylene-*b*-styrene) (for example, SIBS and/or SIBS 50A), polycarbonates, ionomers, biocompatible polymers, other suitable materials, or mixtures, combinations, copolymers thereof, polymer/metal composites, and the like.

20 In some embodiments the sheath can be blended with a liquid crystal polymer (LCP). For example, the mixture can contain up to about 6 percent LCP.

Some examples of suitable metals and metal alloys include stainless steel, such as 304V, 304L, and 316LV stainless steel; mild steel; nickel-titanium alloy such as linear-elastic and/or super-elastic nitinol; other nickel alloys such as nickel-chromium-molybdenum alloys (e.g., UNS: N06625 such as INCONEL® 625, UNS: N06022 such as HASTELLOY® C-22®, UNS: N10276 such as HASTELLOY® C276®, other HASTELLOY® alloys, and the like), nickel-copper alloys (e.g., UNS: N04400 such as MONEL® 400, NICKELVAC® 400, NICORROS® 400, and the like), nickel-cobalt-chromium-molybdenum alloys (e.g., UNS: R30035 such as MP35-N® and the like), nickel-molybdenum alloys (e.g., UNS: N10665 such as HASTELLOY® ALLOY B2®), other nickel-chromium alloys, other nickel-molybdenum alloys, other nickel-cobalt alloys, other nickel-iron alloys, other nickel-copper alloys, other nickel-tungsten or tungsten alloys, and the like; cobalt-chromium alloys; cobalt-chromium-molybdenum alloys (e.g., UNS: R30003 such as

ELGILOY®, PHYNOX®, and the like); platinum enriched stainless steel; titanium; combinations thereof; and the like; or any other suitable material.

As alluded to herein, within the family of commercially available nickel-titanium or nitinol alloys, is a category designated "linear elastic" or "non-super-elastic" which, although may be similar in chemistry to conventional shape memory and super elastic varieties, may exhibit distinct and useful mechanical properties. Linear elastic and/or non-super-elastic nitinol may be distinguished from super elastic nitinol in that the linear elastic and/or non-super-elastic nitinol does not display a substantial "superelastic plateau" or "flag region" in its stress/strain curve like super elastic nitinol does. Instead, in the linear elastic and/or non-super-elastic nitinol, as recoverable strain increases, the stress continues to increase in a substantially linear, or a somewhat, but not necessarily entirely linear relationship until plastic deformation begins or at least in a relationship that is more linear than the super elastic plateau and/or flag region that may be seen with super elastic nitinol. Thus, for the purposes of this disclosure linear elastic and/or non-super-elastic nitinol may also be termed "substantially" linear elastic and/or non-super-elastic nitinol.

In some cases, linear elastic and/or non-super-elastic nitinol may also be distinguishable from super elastic nitinol in that linear elastic and/or non-super-elastic nitinol may accept up to about 2-5% strain while remaining substantially elastic (e.g., before plastically deforming) whereas super elastic nitinol may accept up to about 8% strain before plastically deforming. Both of these materials can be distinguished from other linear elastic materials such as stainless steel (that can also be distinguished based on its composition), which may accept only about 0.2 to 0.44 percent strain before plastically deforming.

In some embodiments, the linear elastic and/or non-super-elastic nickel-titanium alloy is an alloy that does not show any martensite/austenite phase changes that are detectable by differential scanning calorimetry (DSC) and dynamic mechanical analysis (DMTA) analysis over a large temperature range. For example, in some embodiments, there may be no martensite/austenite phase changes detectable by DSC and DMTA analysis in the range of about -60 degrees Celsius (°C) to about 120 °C in the linear elastic and/or non-super-elastic nickel-titanium alloy. The mechanical bending properties of such material may therefore be generally inert to the effect of temperature over this very broad range of temperature. In some embodiments, the mechanical bending properties of the linear elastic and/or non-super-elastic nickel-

titanium alloy at ambient or room temperature are substantially the same as the mechanical properties at body temperature, for example, in that they do not display a super-elastic plateau and/or flag region. In other words, across a broad temperature range, the linear elastic and/or non-super-elastic nickel-titanium alloy maintains its
5 linear elastic and/or non-super-elastic characteristics and/or properties.

In some embodiments, the linear elastic and/or non-super-elastic nickel-titanium alloy may be in the range of about 50 to about 60 weight percent nickel, with the remainder being essentially titanium. In some embodiments, the composition is in the range of about 54 to about 57 weight percent nickel. One example of a suitable
10 nickel-titanium alloy is FHP-NT alloy commercially available from Furukawa Techno Material Co. of Kanagawa, Japan. Some examples of nickel titanium alloys are disclosed in U.S. Patent Nos. 5,238,004 and 6,508,803, which are incorporated herein by reference. Other suitable materials may include ULTANIUM™ (available from Neo-Metrics) and GUM METAL™ (available from Toyota). In some other
15 embodiments, a superelastic alloy, for example a superelastic nitinol can be used to achieve desired properties.

In at least some embodiments, portions of the ablation device 300 may also be doped with, made of, or otherwise include a radiopaque material. Radiopaque materials are understood to be materials capable of producing a relatively bright
20 image on a fluoroscopy screen or another imaging technique during a medical procedure. This relatively bright image aids the user of the ablation device 300 in determining its location. Some examples of radiopaque materials can include, but are not limited to, gold, platinum, palladium, tantalum, tungsten alloy, polymer material loaded with a radiopaque filler, and the like. Additionally, other radiopaque marker
25 bands and/or coils may also be incorporated into the design of the ablation device 300 to achieve the same result.

In some embodiments, a degree of Magnetic Resonance Imaging (MRI) compatibility may be imparted into the ablation device 300. For example, portions of device, may be made of a material that does not substantially distort the image and
30 create substantial artifacts (i.e., gaps in the image). Certain ferromagnetic materials, for example, may not be suitable because they may create artifacts in an MRI image. In some of these and in other embodiments, portions of the ablation device 300 may also be made from a material that the MRI machine can image. Some materials that exhibit these characteristics include, for example, tungsten, cobalt-chromium-

molybdenum alloys (e.g., UNS: R30003 such as ELGILOY®, PHYNOX®, and the like), nickel-cobalt-chromium-molybdenum alloys (e.g., UNS: R30035 such as MP35-N® and the like), nitinol, and the like, and others.

U.S. Patent Application Serial No. 13/750,879, filed on January 25, 2013, and
5 entitled “Methods And Apparatuses For Remodeling Tissue Of Or Adjacent To A
Body Passage”, now published as U.S. Patent Publication No. US20130165926A1, is
herein incorporated by reference.

Additional Embodiments

10 A medical device for renal nerve ablation is disclosed. The medical device
comprises a catheter shaft. An expandable balloon is coupled to the catheter shaft, the
balloon being capable of shifting between a folded configuration and an expanded
configuration. A support structure is coupled to the balloon, the support structure
being capable of shifting the balloon toward the folded configuration. A plurality of
15 elongate flexible electrode assemblies are disposed on the balloon, wherein the
elongate flexible electrode assemblies being oriented at an angle relative to a
longitudinal axis of the balloon.

Alternatively or additionally to any of the embodiments above, the support
structure includes a plurality of elongate support elements extending along the
20 balloon.

Alternatively or additionally to any of the embodiments above, at least some
of the flexible elongate electrode assemblies are disposed between the elongate
support elements.

Alternatively or additionally to any of the embodiments above, the plurality of
25 elongate support elements includes a nickel-titanium alloy.

Alternatively or additionally to any of the embodiments above, the plurality of
elongate support elements includes a polymer.

Alternatively or additionally to any of the embodiments above, at least some
of the electrode assemblies include a pair of adjacent bipolar electrodes.

30 Alternatively or additionally to any of the embodiments above, at least some
of the electrode assemblies include a monopolar electrode.

Alternatively or additionally to any of the embodiments above, at least some
of the electrode assemblies include a temperature sensor.

Alternatively or additionally to any of the embodiments above, the temperature sensor is positioned between a bottom surface of one of the electrode assemblies and an outer surface of the balloon.

Alternatively or additionally to any of the embodiments above, at least one of
5 the elongate flexible electrode assemblies has a proximal portion extending parallel to the longitudinal axis of the balloon, and a bend portion where the elongate flexible electrode assembly angles away from the longitudinal axis of the balloon.

Alternatively or additionally to any of the embodiments above, the proximal portion for each of the elongate flexible electrode assemblies has a different length.

10 Alternatively or additionally to any of the embodiments above, the bend portion of each of the plurality of flexible electrode assemblies is oriented at the same angle relative to the longitudinal axis of the balloon.

Alternatively or additionally to any of the embodiments above, one or more of the elongate flexible electrode assemblies extends substantially linearly along its
15 length and at an angle from the longitudinal axis of the balloon.

Alternatively or additionally to any of the embodiments above, all of the elongate flexible electrode assemblies extends substantially linearly along their length, at an angle from the longitudinal axis of the balloon.

Alternatively or additionally to any of the embodiments above, the balloon
20 includes a plurality of channels formed therein that extend at an angle relative to the longitudinal axis of the balloon.

Alternatively or additionally to any of the embodiments above, the plurality of elongate flexible electrode assemblies alternate with the plurality of channels.

Alternatively or additionally to any of the embodiments above, the plurality of
25 elongate flexible electrode assemblies and the plurality of channels extend at a same angle relative to the longitudinal axis of the balloon.

Alternatively or additionally to any of the embodiments above, the plurality of elongate flexible electrode assemblies are disposed in the plurality of channels.

Alternatively or additionally to any of the embodiments above, the support
30 structure includes a plurality of elongate support elements extending along the balloon, wherein each support element is disposed in a channel.

A medical device for renal nerve ablation is disclosed. The medical device comprises a catheter shaft. An expandable balloon is coupled to the catheter shaft, the balloon having a proximal end, a distal end, and a length extending therebetween. A

support structure is coupled to the balloon, the support structure capable of causing the balloon to fold in a pre-determined manner upon retraction of the balloon into a guide catheter. A plurality of flexible electrode assemblies are coupled to the support structure.

5 Alternatively or additionally to any of the embodiments above, the support structure includes a plurality of elongate support elements extending along the length of the balloon.

 Alternatively or additionally to any of the embodiments above, the elongate support elements extend along the length of the balloon at an angle from a
10 longitudinal axis of the balloon.

 Alternatively or additionally to any of the embodiments above, the balloon includes a plurality of channels extending along the length.

 Alternatively or additionally to any of the embodiments above, the elongate support elements are disposed in the channels.

15 Alternatively or additionally to any of the embodiments above, the channels and elongate support elements extend along the length of the balloon at an angle from a longitudinal axis of the balloon.

 Alternatively or additionally to any of the embodiments above, the electrode assemblies are offset longitudinally.

20 Alternatively or additionally to any of the embodiments above, at least some of the electrode assemblies include a pair of adjacent bipolar electrodes.

 Alternatively or additionally to any of the embodiments above, at least some of the electrode assemblies include a monopolar electrode.

 Alternatively or additionally to any of the embodiments above, at least some
25 of the electrode assemblies include a temperature sensor.

 Alternatively or additionally to any of the embodiments above, the balloon is a compliant balloon.

 Alternatively or additionally to any of the embodiments above, the balloon is a non-compliant balloon.

30 Alternatively or additionally to any of the embodiments above, the support structure extends in a helix over the body of the expandable balloon.

 A method for ablating renal nerves is disclosed. The method comprises advancing the medical device through a guide catheter and into a blood vessel to a position within a renal artery. The medical device comprises a catheter shaft, an

expandable balloon coupled to the catheter shaft, the balloon being capable of shifting between a folded configuration and an expanded configuration, a support structure coupled to the balloon, the support structure being capable of shifting the balloon toward the folded configuration, and a plurality of elongate flexible electrode assemblies disposed on the balloon, wherein the elongate flexible electrode assemblies being oriented at an angle relative to a longitudinal axis of the balloon. The method also includes expanding the balloon, activating at least some of the elongate flexible electrode assemblies, and retracting the balloon into the guide catheter, wherein the interaction between the support structure and the guide catheter shifts the balloon to the folded configuration.

Alternatively or additionally to any of the embodiments above, at least some of the electrode assemblies include a resistive member.

Alternatively or additionally to any of the embodiments above, the resistive member forms a microheater.

It should be understood that this disclosure is, in many respects, only illustrative. Changes may be made in details, particularly in matters of shape, size, and arrangement of steps without exceeding the scope of the disclosure. This may include, to the extent that it is appropriate, the use of any of the features of one example embodiment being used in other embodiments. The invention's scope is, of course, defined in the language in which the appended claims are expressed.

What is claimed is:

1. A medical device for renal nerve ablation, comprising:
a catheter shaft;
an expandable balloon coupled to the catheter shaft, the balloon having a proximal end, a distal end, and a length extending therebetween;
a support structure coupled to the balloon, the support structure capable of causing the balloon to fold in a pre-determined manner upon retraction of the balloon into a guide catheter; and
a plurality of flexible electrode assemblies coupled to the support structure.
2. The medical device of claim 1, wherein the support structure includes a plurality of elongate support elements extending along the length of the balloon.
3. The medical device of any one of claims 1-2, wherein the elongate support elements extend along the length of the balloon at an angle from a longitudinal axis of the balloon.
4. The medical device of any one of claims 1-3, wherein the balloon includes a plurality of channels extending along the length.
5. The medical device of claim 4, wherein the elongate support elements are disposed in the channels.
6. The medical device of claim 5, wherein the channels and elongate support elements extend along the length of the balloon at an angle from a longitudinal axis of the balloon.
7. The medical device of any one of claims 1-6, wherein the electrode assemblies are offset longitudinally.
8. The medical device of any one of claims 1-7, wherein at least some of the electrode assemblies include a pair of adjacent bipolar electrodes.

9. The medical device of any one of claims 1-8, wherein at least some of the electrode assemblies include a monopolar electrode.

10. The medical device of any one of claims 1-9, wherein at least some of the electrode assemblies include a temperature sensor.

11. The medical device of any one of claims 1-10, wherein the balloon is a compliant balloon.

12. The medical device of any one of claims 1-10, wherein the balloon is a non-compliant balloon.

13. The medical device of any one of claims 1-12, wherein the support structure extends in a helix over the body of the expandable balloon.

14. A medical device for renal nerve ablation, comprising:
a catheter shaft;
an expandable balloon coupled to the catheter shaft, the balloon being capable of shifting between a folded configuration and an expanded configuration;
a support structure coupled to the balloon, the support structure being capable of shifting the balloon toward the folded configuration; and
a plurality of elongate flexible electrode assemblies disposed on the balloon, wherein the elongate flexible electrode assemblies being oriented at an angle relative to a longitudinal axis of the balloon.

15. The medical device of claim 14, wherein the support structure includes a plurality of elongate support elements extending along the balloon.

16. The medical device of claim 15, wherein at least some of the flexible elongate electrode assemblies are disposed between the elongate support elements.

17. The medical device of any one of claims 15-16, wherein the plurality of elongate support elements includes a nickel-titanium alloy.

18. The medical device of any one of claims 15-17, wherein the plurality of elongate support elements includes a polymer.

19. The medical device of any one of claims 14-18, wherein at least some of the- electrode assemblies include a pair of adjacent bipolar electrodes.

20. The medical device of any one of claims 14-19, wherein at least some of the electrode assemblies include a monopolar electrode.

21. The medical device of any one of claims 14-20, wherein at least some of the electrode assemblies include a temperature sensor.

22. The medical device of claim 21, wherein the temperature sensor is positioned between a bottom surface of one of the electrode assemblies and an outer surface of the balloon.

23. The medical device of any one of claims 14-22, wherein at least one of the elongate flexible electrode assemblies has a proximal portion extending parallel to the longitudinal axis of the balloon, and a bend portion where the elongate flexible electrode assembly angles away from the longitudinal axis of the balloon.

24. The medical device of claim 23, wherein the proximal portion for each of the elongate flexible electrode assemblies has a different length.

25. The medical device of claim 24, wherein the bend portion of each of the plurality of flexible electrode assemblies is oriented at the same angle relative to the longitudinal axis of the balloon.

26. The medical device of any one of claims 14-25, wherein one or more of the elongate flexible electrode assemblies extends substantially linearly along its length and at an angle from the longitudinal axis of the balloon.

27. The medical device of claim 26, wherein all of the elongate flexible electrode assemblies extends substantially linearly along their length, at an angle from the longitudinal axis of the balloon.

28. The medical device of any one of claims 14-27, wherein the balloon includes a plurality of channels formed therein that extend at an angle relative to the longitudinal axis of the balloon.

29. The medical device of claim 28, wherein the plurality of elongate flexible electrode assemblies alternate with the plurality of channels.

30. The medical device of any one of claims 28-29, wherein the plurality of elongate flexible electrode assemblies and the plurality of channels extend at a same angle relative to the longitudinal axis of the balloon.

31. The medical device of claim 28, wherein the plurality of elongate flexible electrode assemblies are disposed in the plurality of channels.

32. The medical device of claim 28, wherein the support structure includes a plurality of elongate support elements extending along the balloon, wherein each support element is disposed in a channel.

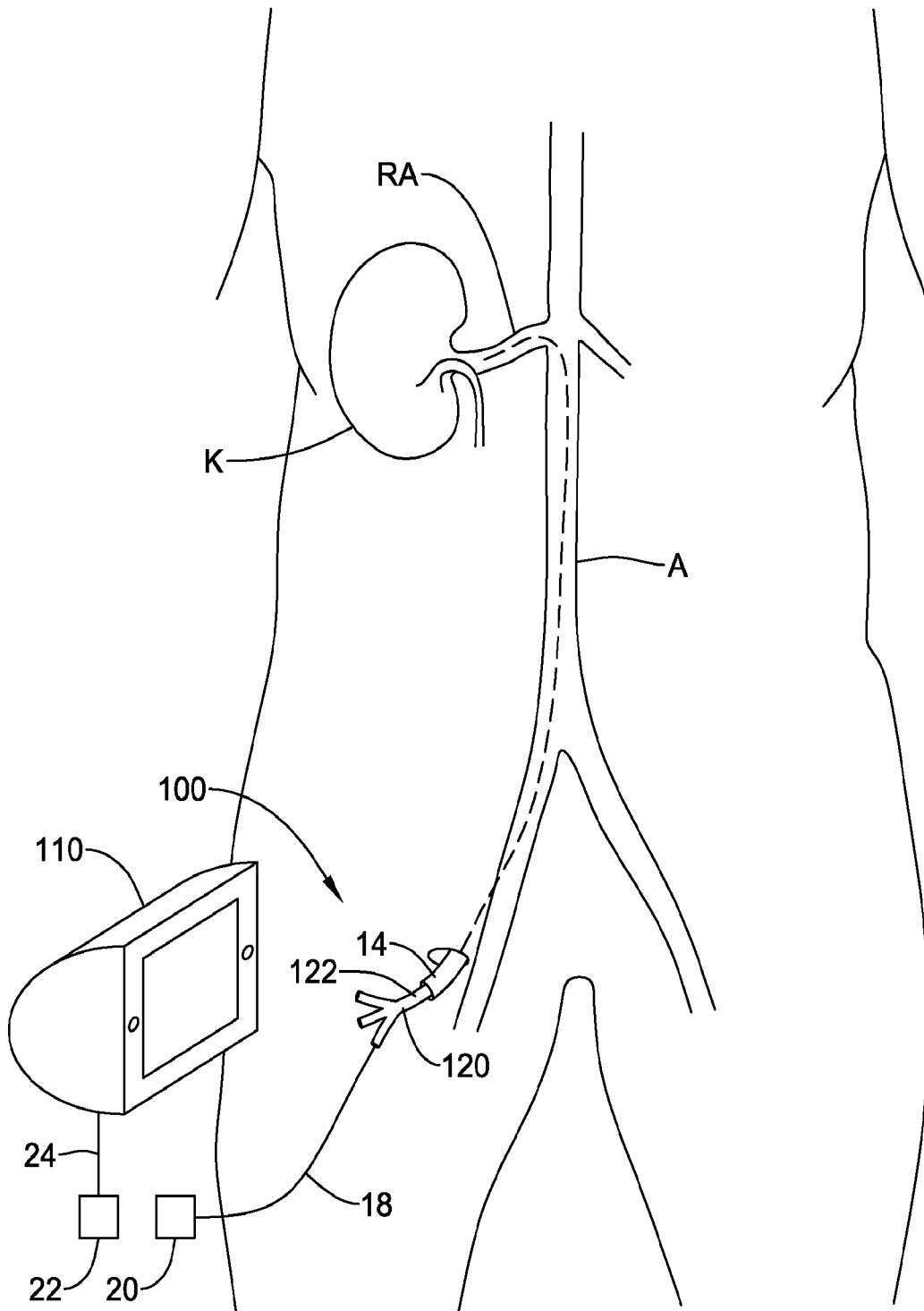

FIG. 1

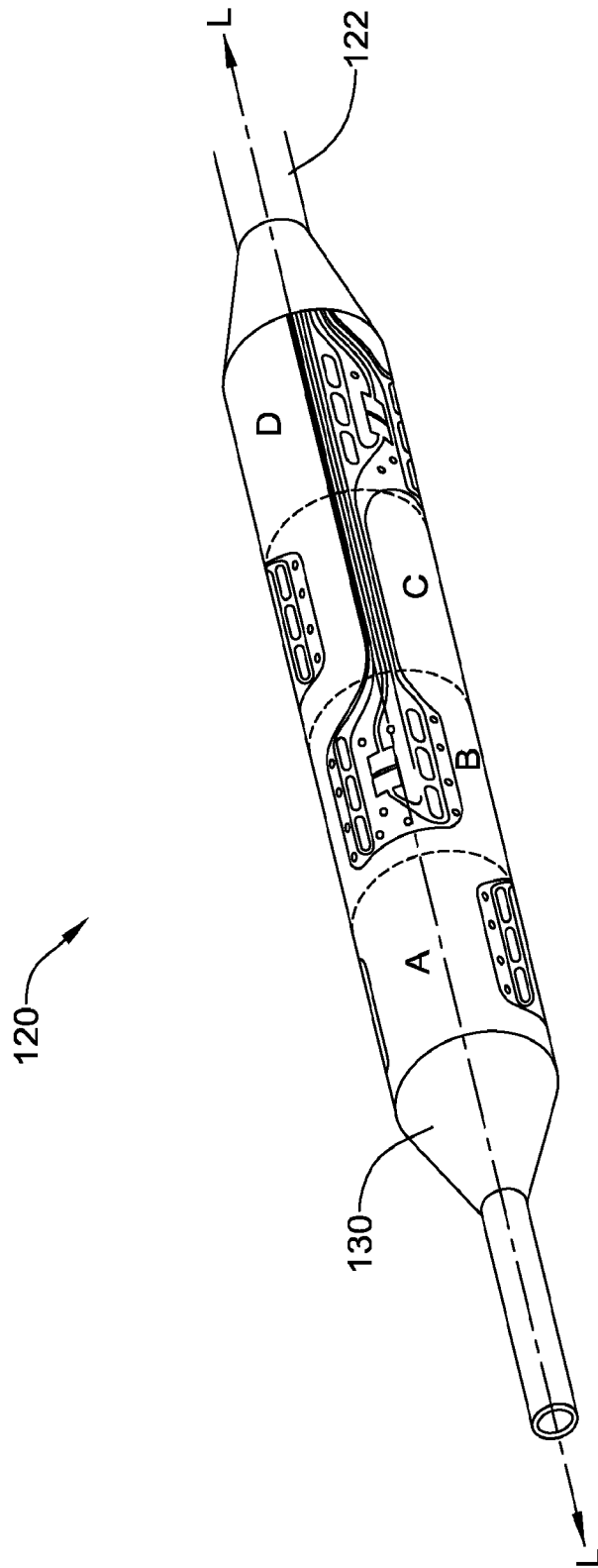

FIG. 2

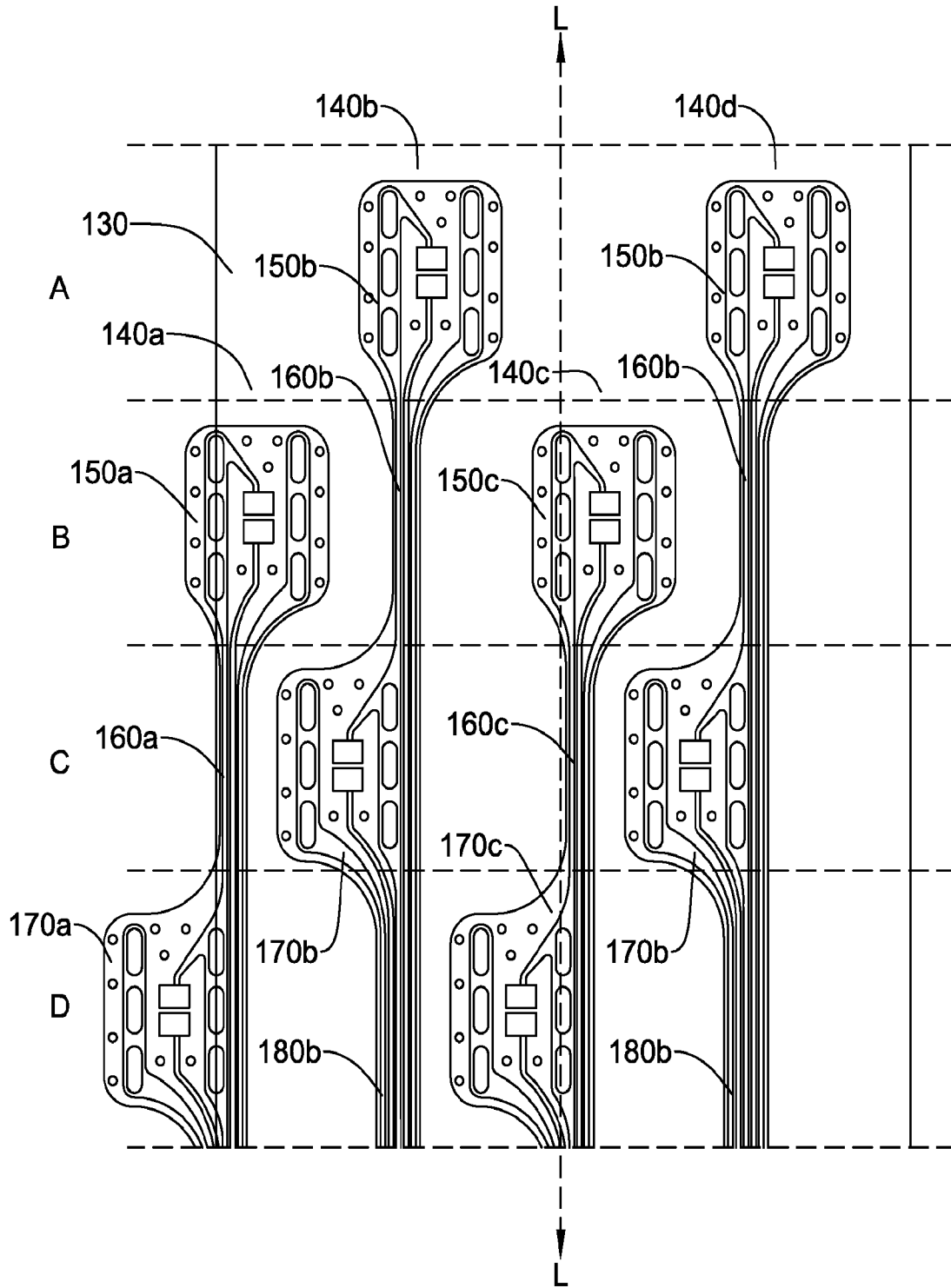

FIG. 3

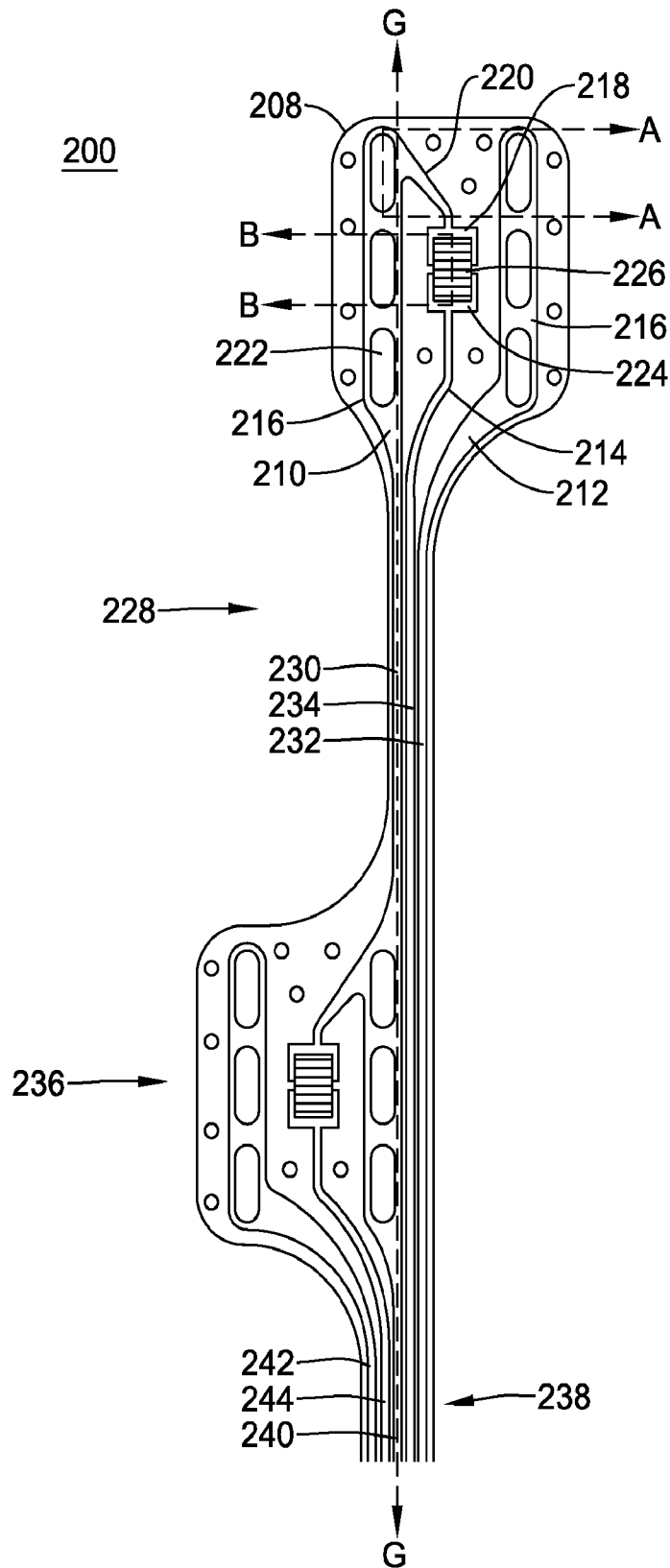

FIG. 4

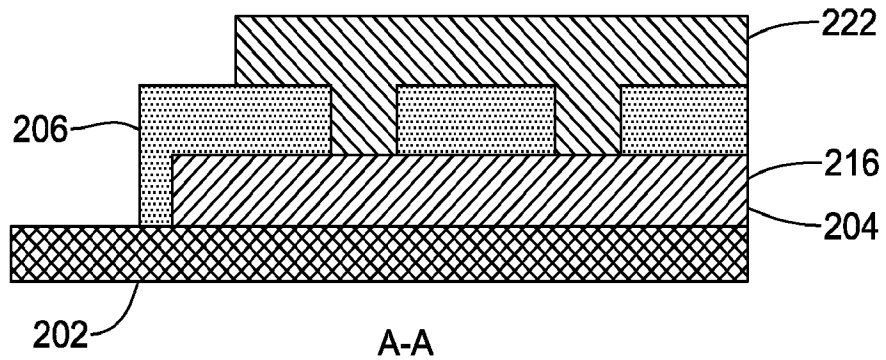

FIG. 5

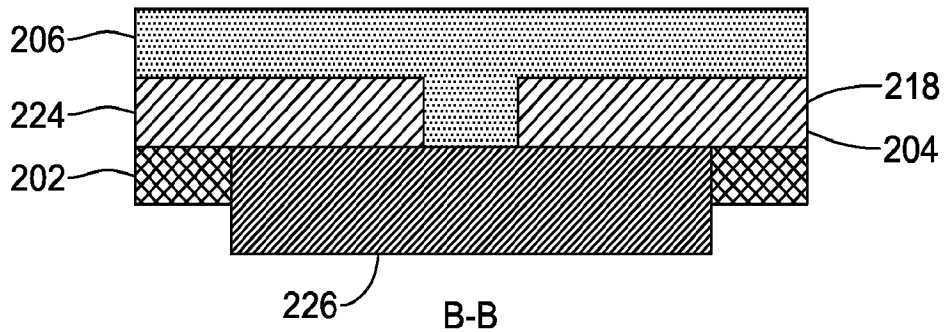

FIG. 6

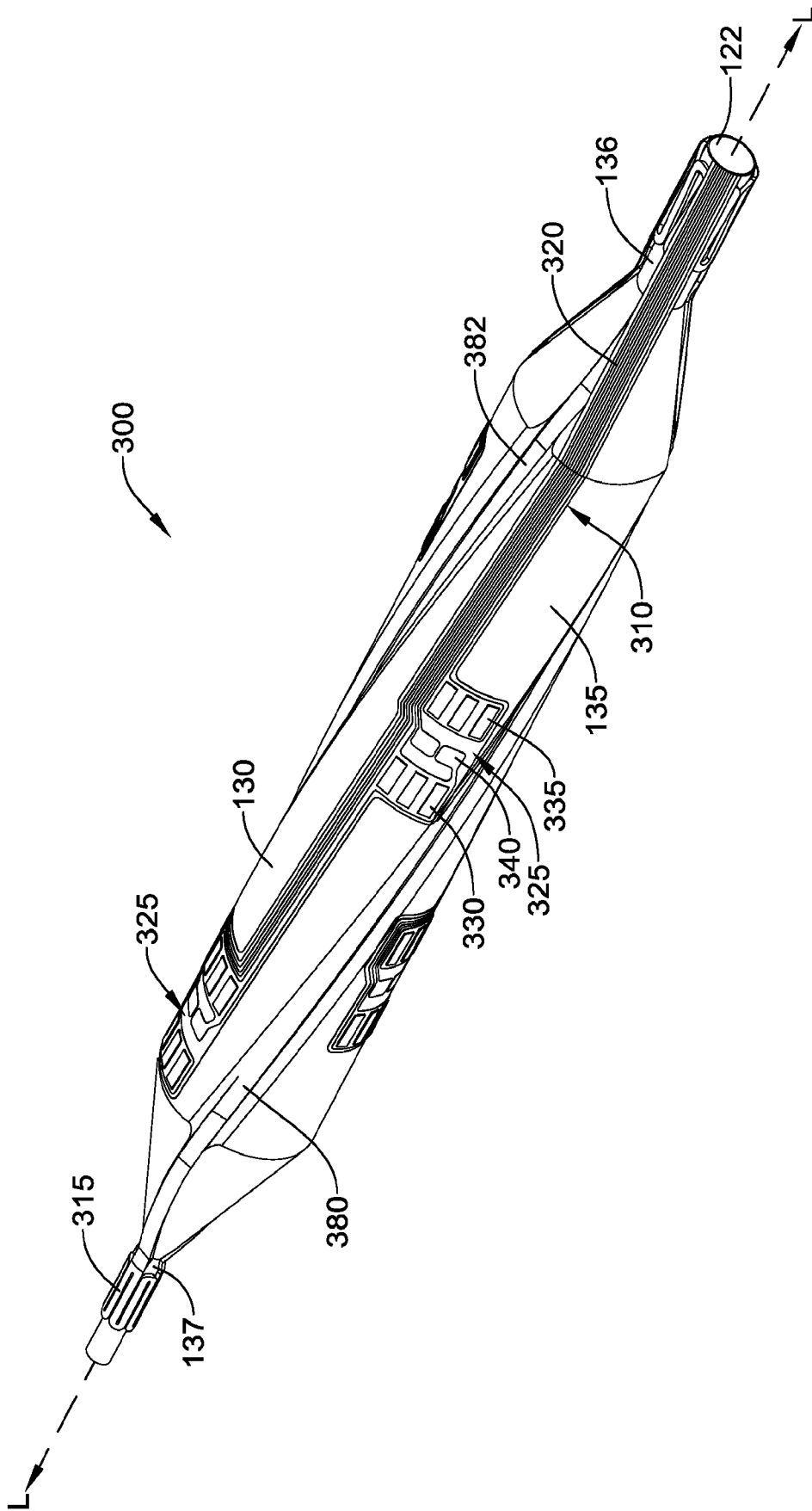

FIG. 7

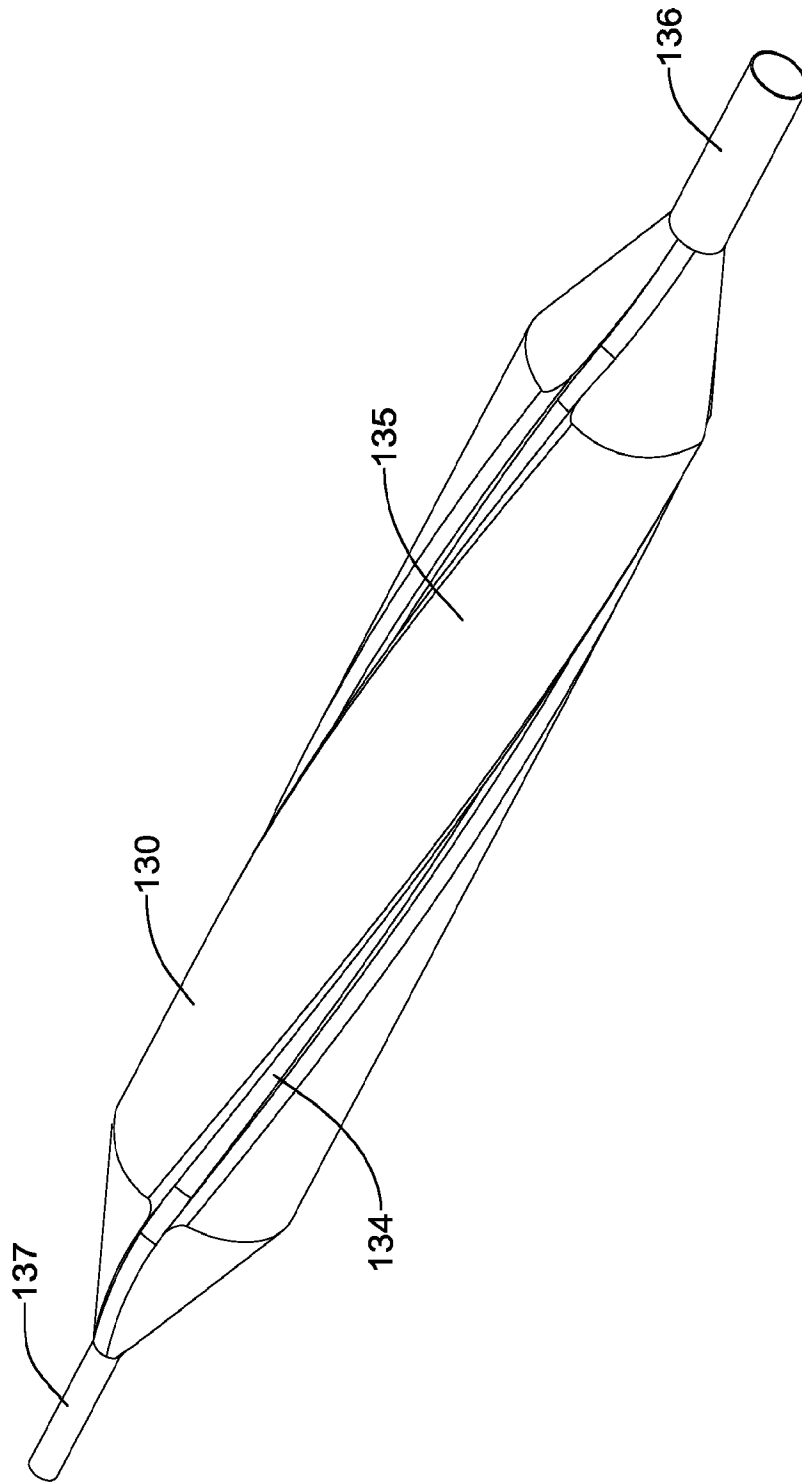

FIG. 8

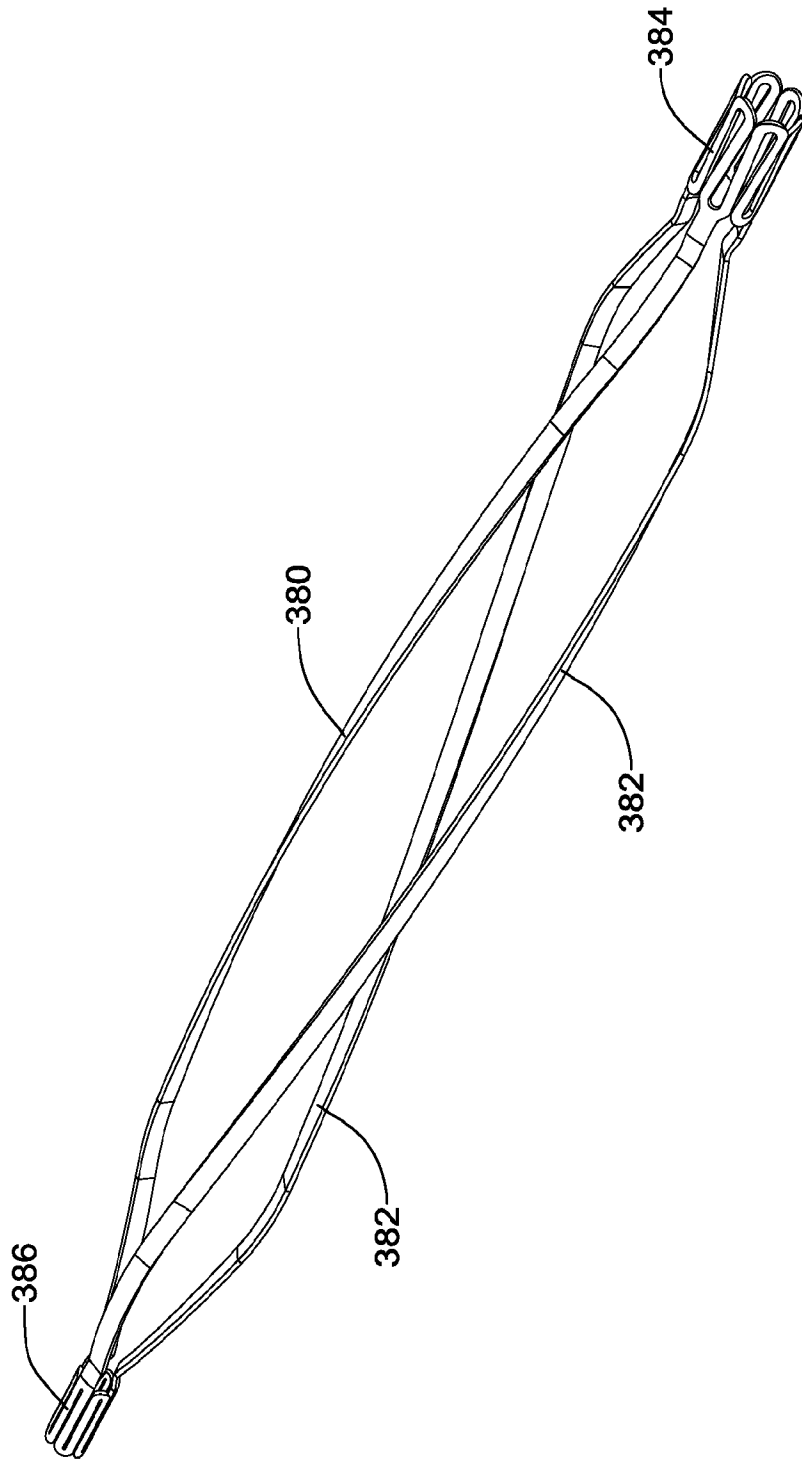

FIG. 9

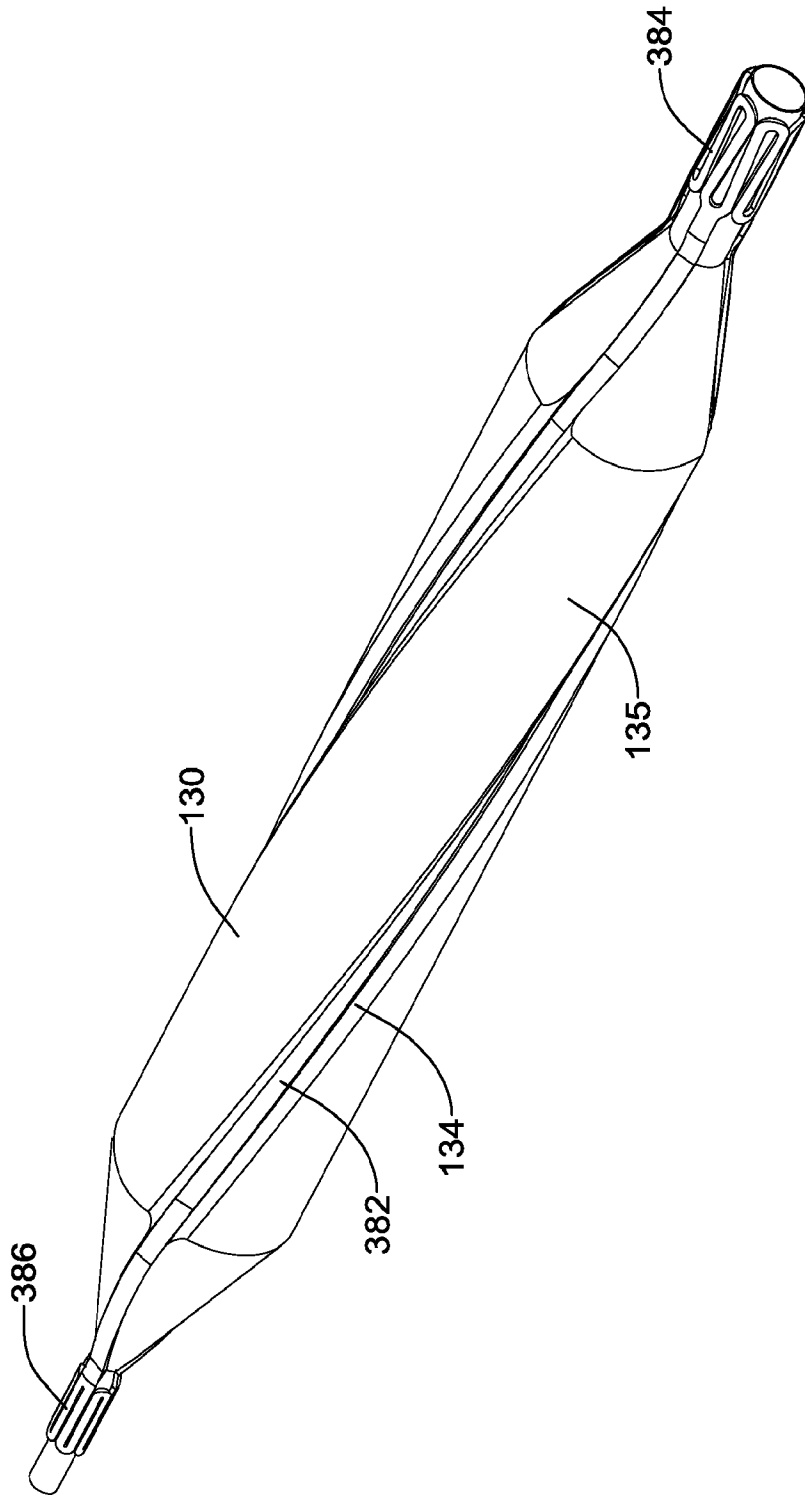

FIG. 10

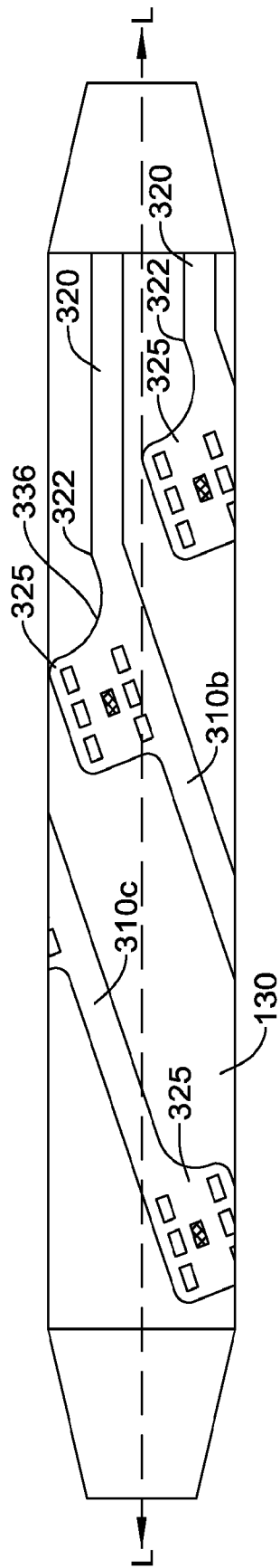

FIG. 11

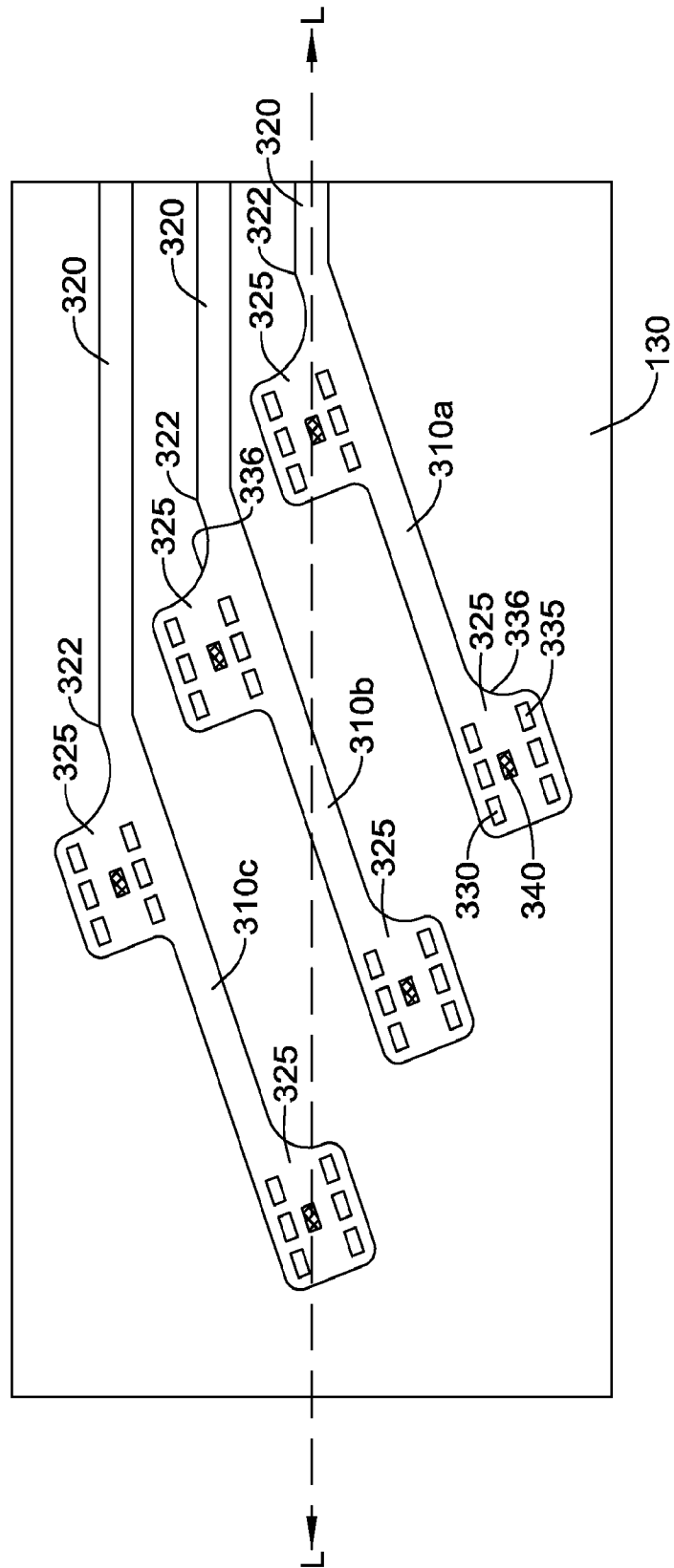

FIG. 12A

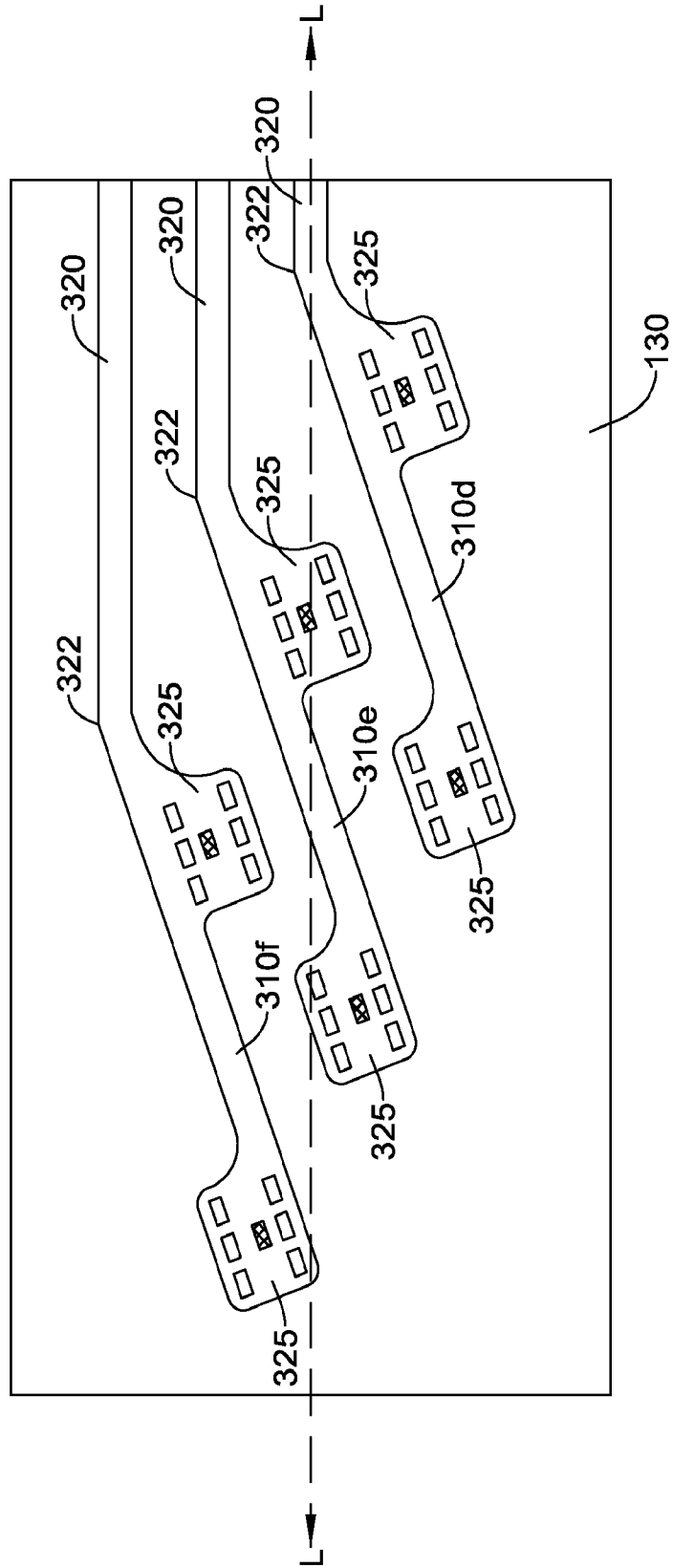

FIG. 12B

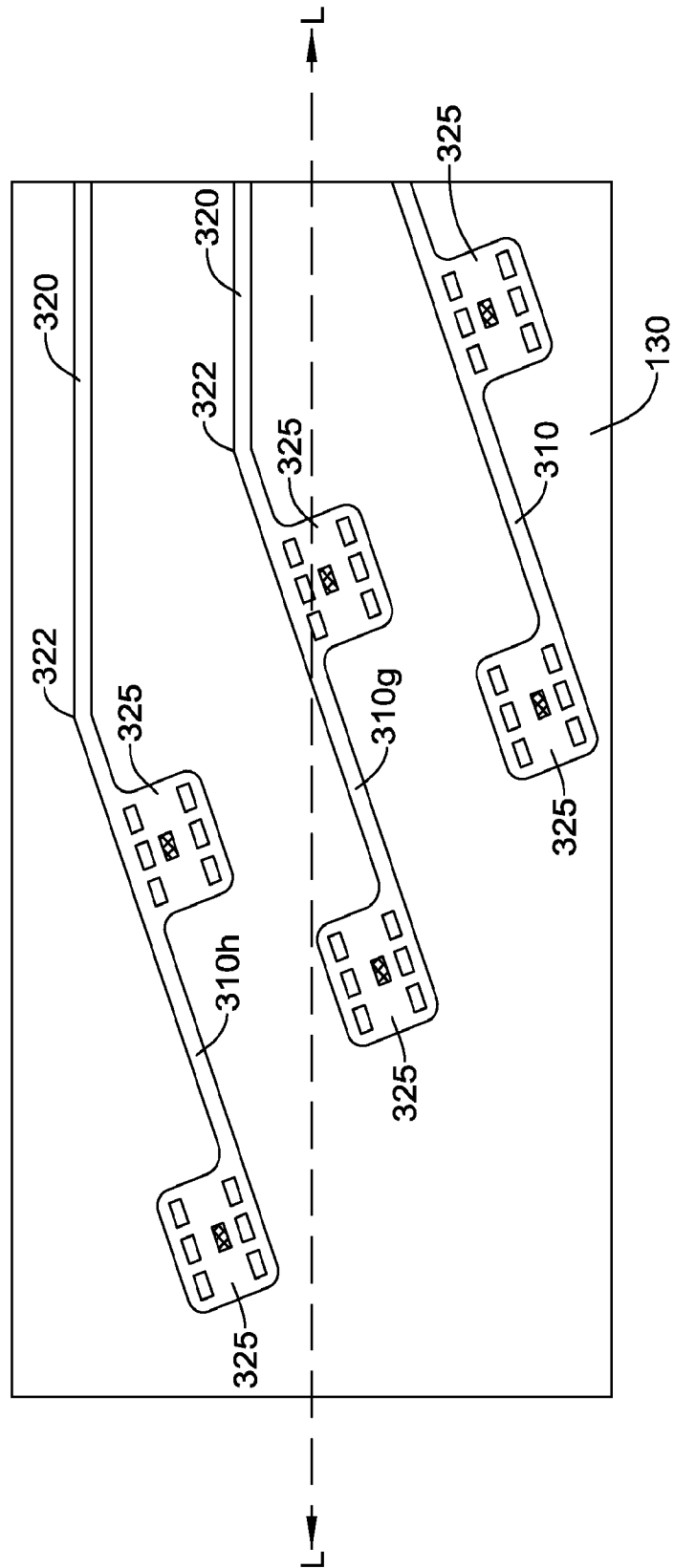

FIG. 12C

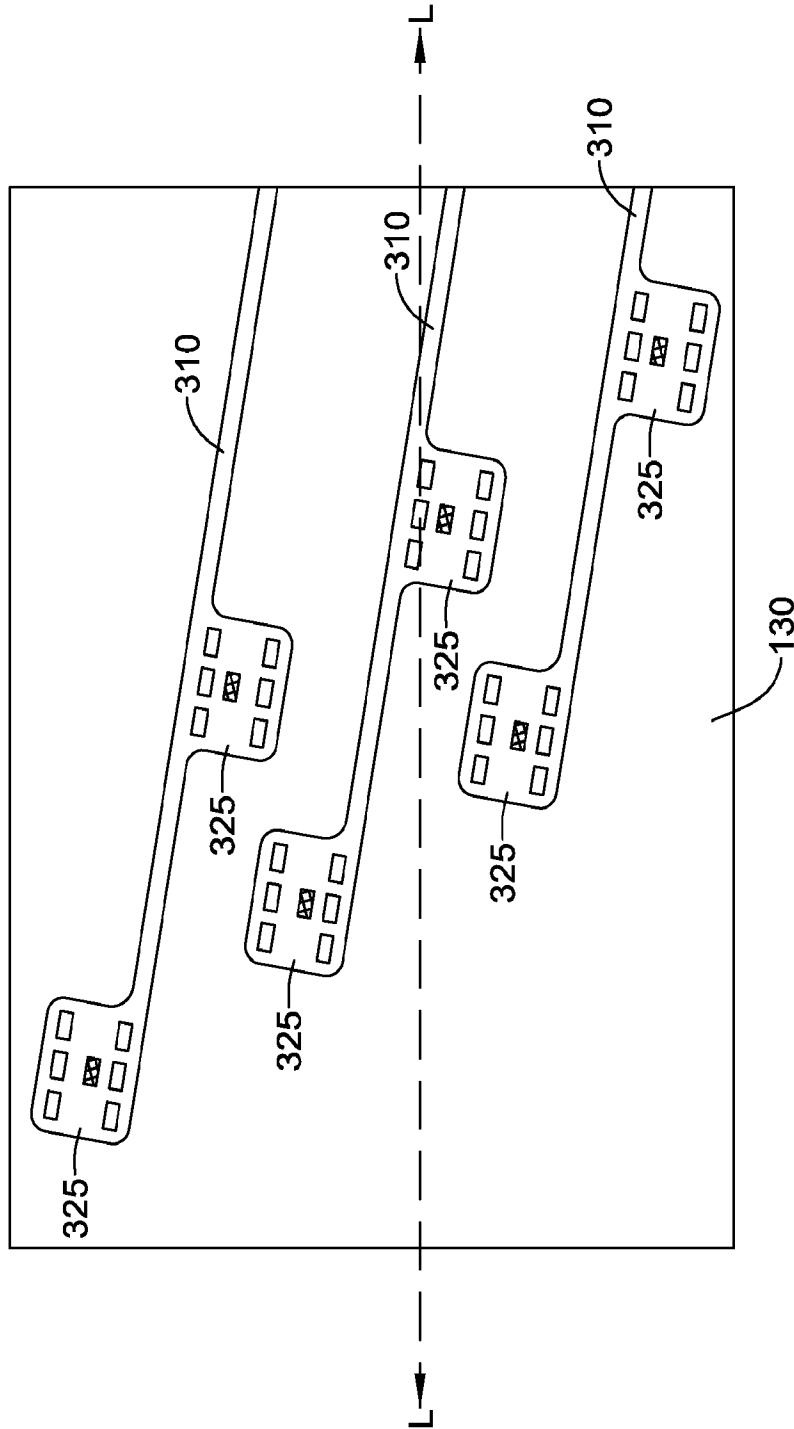

FIG. 12D

INTERNATIONAL SEARCH REPORT

International application No
PCT/US2014/047654

A. CLASSIFICATION OF SUBJECT MATTER
INV. A61B18/14 A61M25/10
ADD.
According to International Patent Classification (IPC) or to both national classification and IPC

B. FIELDS SEARCHED
Minimum documentation searched (classification system followed by classification symbols)
A61B A61M
Documentation searched other than minimum documentation to the extent that such documents are included in the fields searched

Electronic data base consulted during the international search (name of data base and, where practicable, search terms used)
EPO-Internal, WPI Data

C. DOCUMENTS CONSIDERED TO BE RELEVANT		
Category*	Citation of document, with indication, where appropriate, of the relevant passages	Relevant to claim No.
Y	US 2013/165916 A1 (MATHUR PRABODH [US] ET AL) 27 June 2013 (2013-06-27) paragraphs [0308], [0309], [0441]; figure 1b -----	1-32
Y	US 2007/244501 A1 (HORN DANIEL J [US] ET AL) 18 October 2007 (2007-10-18) paragraph [0116]; figures 15A,15B -----	1-32
Y	US 6 142 993 A (WHAYNE JAMES [US] ET AL) 7 November 2000 (2000-11-07) column 4, line 65 - column 5, line 45; figure 3 -----	31
A	US 2012/071870 A1 (SALAHIEH AMR [US] ET AL) 22 March 2012 (2012-03-22) paragraph [0164]; figure 18S ----- -/--	1-32

Further documents are listed in the continuation of Box C.

See patent family annex.

* Special categories of cited documents :

"A" document defining the general state of the art which is not considered to be of particular relevance	"T" later document published after the international filing date or priority date and not in conflict with the application but cited to understand the principle or theory underlying the invention
"E" earlier application or patent but published on or after the international filing date	"X" document of particular relevance; the claimed invention cannot be considered novel or cannot be considered to involve an inventive step when the document is taken alone
"L" document which may throw doubts on priority claim(s) or which is cited to establish the publication date of another citation or other special reason (as specified)	"Y" document of particular relevance; the claimed invention cannot be considered to involve an inventive step when the document is combined with one or more other such documents, such combination being obvious to a person skilled in the art
"O" document referring to an oral disclosure, use, exhibition or other means	"&" document member of the same patent family
"P" document published prior to the international filing date but later than the priority date claimed	

Date of the actual completion of the international search 17 October 2014	Date of mailing of the international search report 27/10/2014
--	--

Name and mailing address of the ISA/ European Patent Office, P.B. 5818 Patentlaan 2 NL - 2280 HV Rijswijk Tel. (+31-70) 340-2040, Fax: (+31-70) 340-3016	Authorized officer Mayer-Martenson, E
--	--

INTERNATIONAL SEARCH REPORT

International application No
PCT/US2014/047654

C(Continuation). DOCUMENTS CONSIDERED TO BE RELEVANT		
Category*	Citation of document, with indication, where appropriate, of the relevant passages	Relevant to claim No.
A	US 2008/188912 A1 (STONE CORBETT W [US] ET AL) 7 August 2008 (2008-08-07) paragraph [0078]; figures 8A-8D -----	1-32
A	US 2011/257622 A1 (SALAHIEH AMR [US] ET AL) 20 October 2011 (2011-10-20) paragraph [0073]; figures 19,20 -----	1-32
A	US 6 423 058 B1 (EDWARDS STUART D [US] ET AL) 23 July 2002 (2002-07-23) abstract; figure 5 -----	1-32

INTERNATIONAL SEARCH REPORT

Information on patent family members

International application No

PCT/US2014/047654

Patent document cited in search report	Publication date	Patent family member(s)	Publication date	
US 2013165916	A1	27-06-2013	AU 2012358143 A1	31-07-2014
			AU 2012358146 A1	31-07-2014
			AU 2012358224 A1	31-07-2014
			AU 2012358227 A1	31-07-2014
			CA 2859989 A1	27-06-2013
			CA 2860327 A1	27-06-2013
			CA 2861622 A1	27-06-2013
			EP 2793689 A2	29-10-2014
			EP 2793690 A1	29-10-2014
			EP 2793724 A2	29-10-2014
			EP 2793725 A1	29-10-2014
			EP 2794001 A1	29-10-2014
			US 2013165916 A1	27-06-2013
			US 2013165917 A1	27-06-2013
			US 2013165923 A1	27-06-2013
			US 2013165924 A1	27-06-2013
			US 2013165925 A1	27-06-2013
			US 2013165926 A1	27-06-2013
			US 2013165990 A1	27-06-2013
			WO 2013096913 A2	27-06-2013
			WO 2013096916 A2	27-06-2013
			WO 2013096919 A1	27-06-2013
			WO 2013096920 A1	27-06-2013
WO 2013096922 A1	27-06-2013			
US 2007244501	A1	18-10-2007	CA 2649428 A1	01-11-2007
			EP 2012863 A1	14-01-2009
			JP 5133337 B2	30-01-2013
			JP 2009534094 A	24-09-2009
			US 2007244501 A1	18-10-2007
			WO 2007123627 A1	01-11-2007
US 6142993	A	07-11-2000	NONE	
US 2012071870	A1	22-03-2012	AU 2011252976 A1	08-11-2012
			CA 2797130 A1	17-11-2011
			CN 103118620 A	22-05-2013
			EP 2568905 A2	20-03-2013
			JP 2013529109 A	18-07-2013
			US 2012071870 A1	22-03-2012
			US 2014058197 A1	27-02-2014
			WO 2011143468 A2	17-11-2011
US 2008188912	A1	07-08-2008	AU 2007310991 A1	24-04-2008
			CA 2666663 A1	24-04-2008
			EP 2076194 A2	08-07-2009
			EP 2455034 A2	23-05-2012
			ES 2407329 T3	12-06-2013
			JP 5559539 B2	23-07-2014
			JP 2010507404 A	11-03-2010
			US 2008188912 A1	07-08-2008
			US 2012158101 A1	21-06-2012
			WO 2008049087 A2	24-04-2008
US 2011257622	A1	20-10-2011	AU 2011232335 A1	11-10-2012
			CA 2793737 A1	29-09-2011
			CN 102917748 A	06-02-2013
			EP 2550040 A2	30-01-2013

INTERNATIONAL SEARCH REPORT

Information on patent family members

International application No

PCT/US2014/047654

Patent document cited in search report	Publication date	Patent family member(s)	Publication date	
		JP 2013521995 A	13-06-2013	
		US 2011257622 A1	20-10-2011	
		US 2012116438 A1	10-05-2012	
		WO 2011119857 A2	29-09-2011	

US 6423058	B1	23-07-2002	AU 4982400 A	17-11-2000
			US 6423058 B1	23-07-2002
			WO 0066020 A1	09-11-2000
