

May 5, 1925.

1,536,494

A. HENKES

PROJECTILE FOR USE IN CATCHING WHALES AND OTHER MAMMALS

Filed Dec. 30, 1920

3 Sheets-Sheet 1

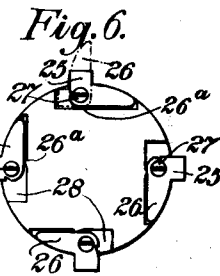
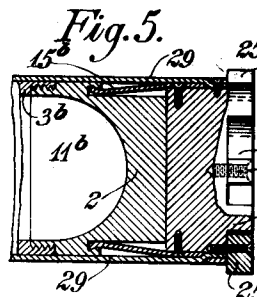
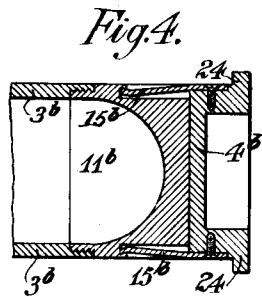
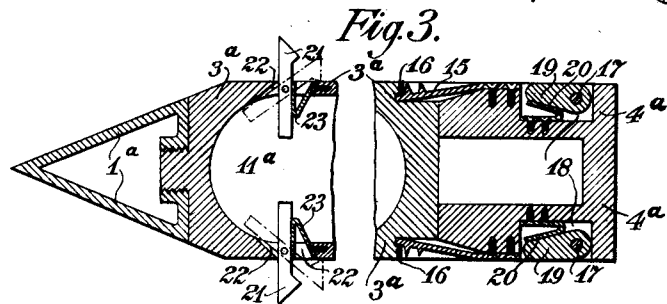
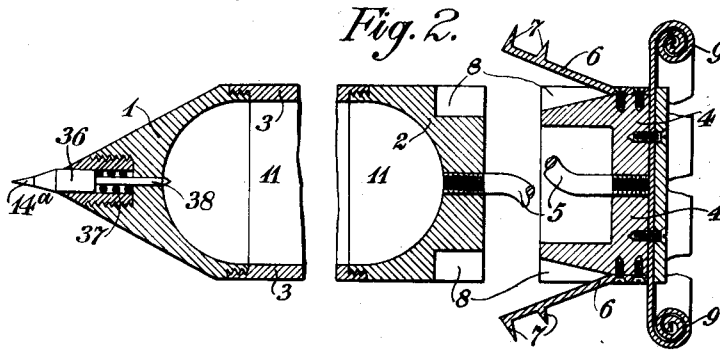
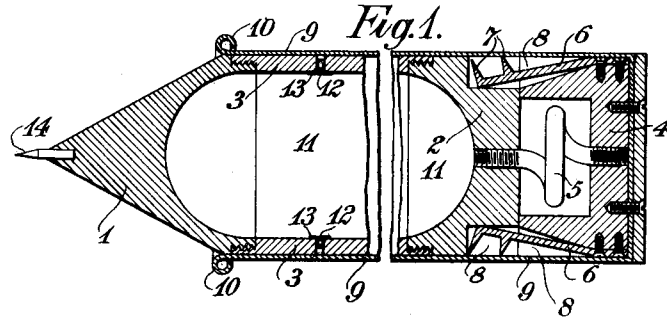

INVENTOR,
Augustus Henkes,
BY
E. J. Siggers
ATTORNEY.

May 5, 1925.

1,536,494

A. HENKES

PROJECTILE FOR USE IN CATCHING WHALES AND OTHER MAMMALS

Filed Dec. 30, 1920

3 Sheets-Sheet 2

Fig. 7.

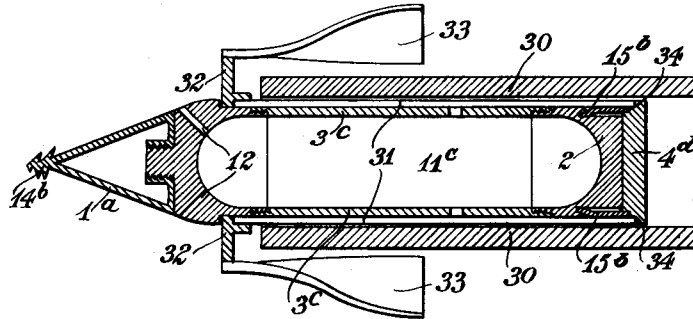

Fig. 8.

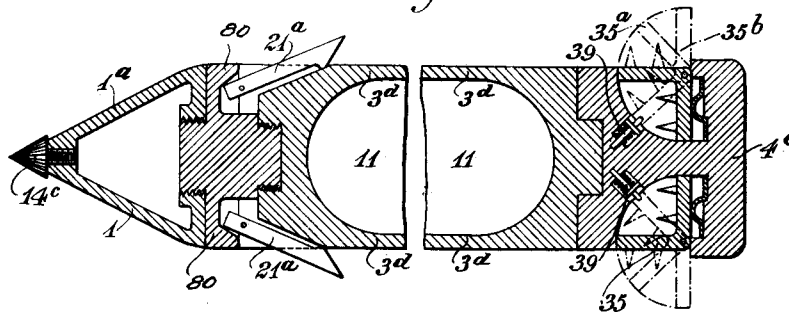
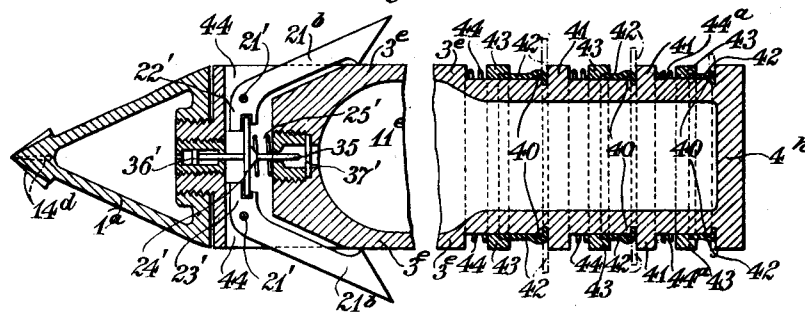

Fig. 9.



INVENTOR,
Augustus Henkes,
BY
E. J. Siggers,
ATTORNEY.

May 5, 1925.

1,536,494

A. HENKES

PROJECTILE FOR USE IN CATCHING WHALES AND OTHER MAMMALS

Filed Dec. 30, 1920

3 Sheets-Sheet 3

Fig. 10.

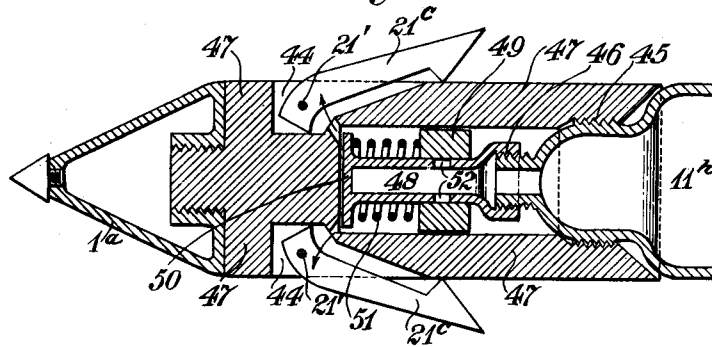

Fig. 11.

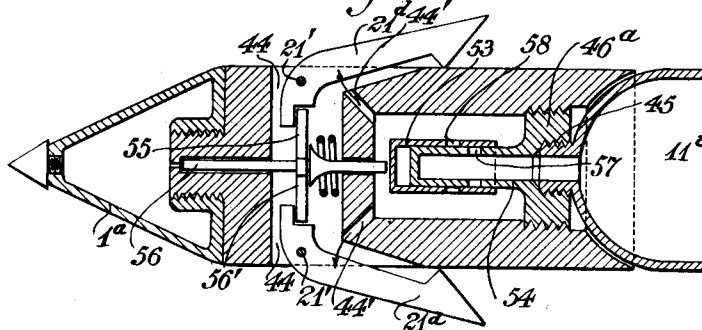

Fig. 12.

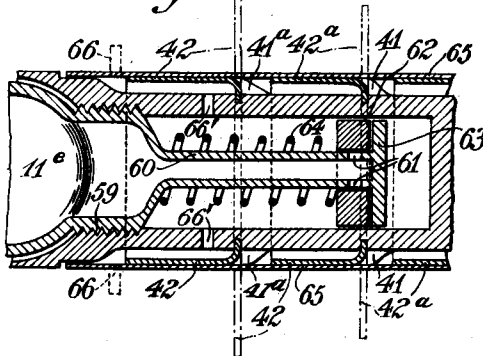
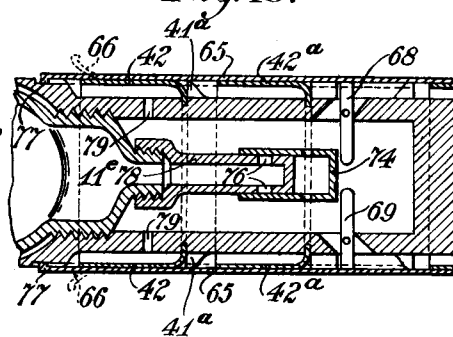

Fig. 13.



INVENTOR,
Augustus Henkes,
BY
C. J. Siggers,
ATTORNEY.

UNITED STATES PATENT OFFICE.

AUGUSTUS HENKES, OF ROTTERDAM, NETHERLANDS, ASSIGNOR TO IMPROVED WHALING LIMITED, OF LIVERPOOL, ENGLAND, A CORPORATION OF GREAT BRITAIN.

PROJECTILE FOR USE IN CATCHING WHALES AND OTHER MAMMALS.

Application filed December 30, 1920. Serial No. 434,013.

To all whom it may concern:

Be it known that I, AUGUSTUS HENKES, a subject of Her Majesty the Queen of the Netherlands, and resident of Rotterdam, in the Kingdom of the Netherlands, have invented certain new and useful Improvements in or Relating to Projectiles for Use in Catching Whales and Other Mammals; of which the following is a specification.

Whale hunting is at present conducted by special steamers or motor-boats having fitted on the bow a recoil-swivel gun for firing the harpoon. The said harpoon has a hollow conical point (shell) filled with powder, the firing of which is effected when the harpoon is lodged in the whale-body. By means of a line attached to the harpoon a connection is constituted between whale and whale-catcher, and it is well-known in the art that it is essential to keep this connection intact in order that the whale may be secured. Should the gear part, or the harpoon draw, the whale might escape, or if killed, would sink, whereby many whales are lost.

In order that the harpooned whale may be prevented from escaping, or the dead whale be safely hauled in, the head of the harpoon is provided with folding barbs which owing to the explosion and/or to the pull on the line spread themselves and become anchored in the whale-body. When hauled in the whale-body is inflated by means of an air-pump whereby its buoyancy is sufficiently increased so as to allow its easy towage or its floating when anchored.

The above method of catching whales and other marine mammals such as bottlenose-whales, has many disadvantageous features. The shot is never quite reliable owing to the harpoon having to uncoil and carry away the heavy hemp or manila forerunner of the line. Moreover, the weight of this forerunner greatly depends upon whether the hemp or manila is dry or saturated with water. This explains why in some instances the harpoon may be shot right through the whale, and at other times may not have sufficient penetrating momentum. These drawbacks might to a certain extent be met by timing the firing of the shell more accurately than hitherto and by taking the range in accordance with the condition of the forerunner. However, the firing distance which

on account of the use of the forerunner is already extremely limited, is thus still further reduced so that many a time the whale, being stalked too closely, is scared away.

Another inconvenience of the present day method is that making ready for a new shot, when port and starboard lines are out, takes a considerable time. During this time, and also during the securing of a harpooned whale, the catching capacity is practically nil, and many a chance to place an easy shot is lost on that account.

In order to avoid these and many other disadvantages amongst which should still be mentioned the limited area covered by the bow-gun of the ordinary whale-catchers, owing to which whales rising on the side or astern often cannot be fired at, it has already been proposed to use a projectile which avoids the necessity of establishing a connection between the catcher and the whale. For this purpose a projectile has been suggested which contains a heavy explosive charge having for its duty to kill the whale and produce a considerable volume of gases for inflating the body and keeping the same afloat. The said projectile is provided with a detachable member adapted when it comes into contact with the whale-body to close the entry-hole made by the projectile and consequently to prevent the explosion gases from escaping. This projectile, however, has never had any practical use and it could never have been a success as the explosion-gases would be generated so instantaneously and under such a high pressure that they could not be kept closed up and would escape through the entry-hole of the projectile as the aforesaid detachable member could not possibly withstand the high internal pressure, and/or through the wounds inflicted by the bursting projectile. It is therefore pretty sure that the use of the aforesaid inflating projectile would mean a certain loss of the whale. An incendiary shell or bomb for use against airships and the like has been suggested the said shell being provided with a chamber to contain compressed oxygen or other combustion-supporting agent which is released from the said chamber by means of a detonator and fuses.

The present invention has for its object

to provide an inflating whaling projectile which requires no line and which when correctly shot positively keeps the whale afloat, and may be used over and over again.

6 With this object in view I so construct my projectile that the gases for inflating the whale-body are not produced under an exceedingly high explosion-pressure, but in a non-explosive manner. To this end I may

10 produce the required gases by chemical action or I may provide the projectile with a chamber filled with highly compressed or liquefied gas which, when the projectile has penetrated the whale-body, is allowed

15 by suitable means to escape under a convenient pressure through passages in the gas-chamber and inflate the said body.

When inflating the whale or other marine mammal in accordance with my new principles I may elect between a great many gases and control the rate of gas-generation that is to say the quantity of gas per minute and the pressure under which the gas is produced. It will be readily understood that

25 no such control would practically be possible when producing the inflating gases by explosion.

The inflating gas to be used should preferably be non-poisonous, as otherwise amongst others the cutting up of the catch might offer dangers to the workmen. For the same reason it should not be inflammable, and be odourless as otherwise it might impart undesired smell to blubber and meat.

35 Finally the gas should be comparatively cheap and easily procurable, and if possible retard decomposition of the whale-body. A gas which fulfils all these conditions is carbon dioxide, but I wish to remark that

40 my invention is not at all limited to any particular gas.

When constructing a projectile in accordance with the present invention special care should be paid to the means for allowing

45 the gas to escape at the required moment, for it is quite essential that these means be absolutely reliable. Different means for realizing this object will be described hereinafter.

50 The annexed drawing illustrates some embodiments of my present invention. In this drawing:—

Figure 1 is a longitudinal sectional view of one embodiment, showing the detachable member for plugging up the entry hole held in engagement with the body of the projectile.

55

Figure 2 is a longitudinal sectional view of a somewhat different projectile from that shown in Figure 1, with the detachable plugging member disengaged from the body of the projectile.

60

Figure 3 is a longitudinal sectional view of a further embodiment of my invention.

65 Figure 4 shows a longitudinal section or

part of a further embodiment of my invention.

Figure 5 is a longitudinal view of part of a further embodiment of my invention.

Figure 6 is a rear elevation view of the 70 projectile illustrated in Figure 5.

Figure 7 shows a longitudinal section of a still further embodiment of my invention, with part of the gun muzzle.

Figure 8 illustrates a longitudinal section 75 of a seventh embodiment of my invention.

Figures 9, 10, 11, 12 and 13 show sections of various modified constructions of projectiles in accordance with the present invention.

80

In Figures 1 and 2, the numeral 1 designates the head, and 2 the bottom part of the projectile body 3 to which both are secured by screw-connections. The member 4, serving to plug up the entry-hole in the whale 85 or other mammal is connected with the bottom part 2 by a spirally wound metal rod 5 in such a manner that the said member and the said part are normally in contact with one another. Secured to the plugging member 4 are a plurality of spring 90 blades 6 which are provided with barbs 7 and normally held in position in recesses 8 in the bottom part 2 and the plugging member 4 by means of a thin metal jacket 95 or sleeve 9 normally fitting closely around the projectile except the head 1, the said jacket having its front edge coiled as at 10 so as to be adapted to be stripped or shoved off when the projectile enters the 100 body of a whale or other mammal. The head 1, body 3 and bottom part 2 enclose a chamber 11 filled with compressed inflating gas or liquefied gas, or with substances adapted to develop such gas, and the wall 105 of the body 3 has holes 12 to allow the gas to escape into the body of the whale or other mammal when the jacket 9 or sleeve which normally keeps the said passages 12 closed, is stripped or shoved off in the manner 110 described above. In order to prevent undue loss of gas I may provide in each hole 12 a short piece of rubber tube 13 which owing to the internal pressure in chamber 11 is forced against the walls of the said hole 115 and against the inner face of the jacket 9, thereby ensuring a perfectly tight joint.

The projectile shown in Figure 1 is provided at its nose with a sharp pin 14 for ensuring easy entry. In Figure 2, the nose 120 of the projectile is provided with a sharp point 14^a secured to a plunger 36 normally held in its extreme outward position by a spring 37. The said plunger 36 is provided on its inner face with a pin 38 adapted to 125 project into the chamber 11. When the point 14^a is forced inward against the action of the spring 37 owing to the projectile penetrating the object the pin 38 enters the chamber 11 thereby providing means for 130

starting the liberation or the production of the inflating gas in some well-known manner.

When the projectile penetrates the body of a whale or other mammal the sleeve 9 will be stripped or shoved off as stated (see Figure 2) whereby the spring-blades 6 are released so as to spread out and ensure a firm grip in the body of the whale. Consequently, the member 4 is stopped, thereby braking and finally stopping the body of the projectile owing to its connection therewith by means of the spirally wound rod 5, as the stretching of the said rod requires a considerable amount of energy. Since the sleeve 9 is stripped or shoved off the gas in the chamber 11 is free to escape through the apertures 12, Figure 1, and to enter the cavities of the whale or other mammal-body.

In Figure 3 the hollow head 1^a of the projectile contains an explosive charge so as to form a shell the explosion of which in the whale-body is taken advantage of to stop the flight of the projectile. The plugging member 4^a is detachably connected with the projectile-body 3^a by means of barbed spring-blades 15, which are secured to the said plugging member and normally engaged with their free ends in undercut recesses 16 of the body 3^a but adapted on an axial displacement of the member 4^a relative to the body 3^a to be disengaged from the said recesses and swing out in the same manner as the spring-blades 6 in Figure 2.

Pivotaly mounted on pins 17 in recesses 18 of the plugging member 4^a are wings 19 loaded by springs 20 having a tendency to press the said wings outwards, but as long as the projectile is in the gun these wings are held in the position shown, thereby keeping the springs 20 under compression.

Pivoted to the body 3^a are a plurality of claws 21 having freedom of rotary motion in openings 22 provided in the wall of the body 3^a and normally projecting outside the said body under the action of springs 23.

When the described projectile is fired, the wings 19 are pressed outward by the springs 20. As the projectile penetrates the whale-body, the claws 21 are turned inward against the action of the springs 23, and this motion may be utilized in any well-known manner for starting a chemical action in the chamber 11^a (which is supposed to be filled with substances adapted by their action upon one another to produce inflating gas under a moderate pressure above atmospheric pressure), and/or for igniting the explosive charge in the hollow head 1^a. The claws 21 having a tendency to again move outward owing to the pressure exerted by the springs 23 prevent the body 3 from recoiling too far under the influence of the said explosion by firmly gripping the whale-body. The entry-hole is closed by the member 4 which owing

to the action of the extending wings 19 is prevented from penetrating the whale, and after being detached from the still moving body 3 is firmly held in position by the barbed spring-blades 15 engaging the walls of the said entry-hole. The openings 22 in the body allow inflating gases to flow into the cavities of the whale body.

I wish to remark that the inward movement of the claws 21 on the projectile penetrating a whale body may also be utilized for piercing a wall of a gas-tight chamber filled with inflating gas under suitable pressure, whereby this gas is allowed to flow out. The details of the constructions required for producing the firing, chemical action, starting, or piercing action of the claws 21 are not shown in the drawing as they are sufficiently known in the art.

Figure 4, shows part of a projectile the plugging member 4^b of which is provided with a plurality of projections 24 integral therewith and serving to impart to the projectile rotary motion about its axis, provided a grooved or rifled gun muzzle be used.

A similar construction is shown in Figures 5 and 6, however, the projections 25 here are not integral with the plugging member 4^b but form parts of the wings 26 mounted on pivots 27 in recesses 28 in the said member. The arrangement is such that as soon as the projectile has left the gun-muzzle the wings 26, owing to the centrifugal force produced by the rotary movement of the projectile about its axis, are swung outwards about their pivots and kept in their extended positions by suitable catches 26^a; they then serve to withhold the member 4^c and disengage same from the bottom piece 2 in the manner described above.

Secured to the plugging member is a rubber sleeve 29 which normally covers the bottom piece 2 and part of the body 3^b. When the member 4^c is detached from the bottom piece 2 the sleeve 29 is stripped or shoved off from the piece 2 and then also serves to close the entry hole since it is forced by the internal pressure of the inflating gases and by the expanding action of the members 15^a against the walls of the said hole.

The projectile illustrated in Figure 7 comprises a hollow head 1^a containing an explosive charge and provided at its front end with a screw blade 14^b to permit of an easy entry of the projectile. The chamber 11^c of the body 3^c contains suitable substances for producing inflating gas as described above. 30 is the gun muzzle. The body 3^c, the bottom piece 2 and the plugging member 4^a are provided with longitudinal grooves 31 cut on their outer side; the forward end of the body is surrounded by a disc 32 which is temporarily held in position by suitable means not shown. The said disc 32 is pro-

vided with projections engaging the grooves 31, and with blades 33 adapted to impart rotary motion to the projectile when fired. When the projectile penetrates the whale-body the disc 32, owing to its diameter exceeding that of the projectile-body 3^e, is retarded and slides along the said body until its comes into contact with the stop-ends 34 of the grooves 31 in the member 4^d, whereby the said member 4^d is detached from the bottom piece 2. The member 4^d is provided with spring blades 15^b to ensure a firm grip in the walls of the entry-hole. It will be understood that with this construction both the disc 32 and the member 4^d serve to plug up the entry-hole.

Referring to Figure 8, the projectile here is composed of a metal body or bottle 3^d filled with liquid carbon dioxide, a plugging member 4^e, a cap or nose piece 1^a in the form of a shell, and an intermediate piece 80 between the head 1^a and body 3^d. Screwed in the head 1^a is a sharp point 14^c provided with cutting ridges to ensure easy entry of the projectile, and if desired with ignition means (not shown) for the shell. Pivoted to the intermediate piece 80 are spring loaded folding barbs 21^a similar to the claws 21^a in Figure 3. Pivotaly mounted in the plugging member 4^e is a number of spring loaded L shaped folding barbs 35 held in their inward positions (shown in full lines) as long as the projectile has not left the gun-muzzle. The inturned legs of the said barbs 35 are provided with sharp points on their inner faces. As soon as the projectile leaves the gun-muzzle (not shown) the folding barbs 35 swing outward into the positions 35^a in which they are held by spring catches 39 and in which positions the sharp points on the inturned legs do not yet project from the projectile body. When the projectile enters a whale-body the said barbs 35, owing to the resistance offered by the object, are forced into their positions 35^b against the action of the catches 39. The plugging member 4^e is now prevented by the outturned legs of the barbs 35 from entering the object, whereas the sharp points on the inturned legs grip the flesh so that the entry-hole is firmly plugged up. The barbs 21^a and/or the barbs 35 may be used for igniting the shell 1^a and/or for liberating the inflating gas and/or for starting the production of said gas.

It should be noticed that projectiles constructed in accordance with my invention may for the main part be used over and over again after being removed from the whale or other body, whereas the known inflating whaling projectiles, owing to the heavy explosion caused thereby, will be blown to pieces and completely lost.

In the construction shown in Figure 9 the gas container-part of the projectile and the

plug-member are shown as being formed in one piece. The inflating-gas containing chamber or the chamber containing the material from which the inflating gas may be evolved by chemical action is indicated at 11^e and the plug-part integral with the body part 3^e is indicated generally by the reference 4^h. The exterior of the part 4^h is recessed at intervals so as to form recesses 40 and circular rings 41. These latter form abutments for resilient washers 42 preferably of rubber, the washers 42 being retained in the down position by rings 43. Springs 44^a are interposed between the rings 43 and the adjacent abutments. The washers 42 may be all of the same diameter or they may decrease in diameter rearwardly of the projectile and they may be all of the same thickness or they may decrease in thickness forwardly so as to facilitate the plugging action. The nose of the projectile is provided with barbs 21 which are pivoted as at 21^b and extended to form bell crank levers the ends 22', 23', of which are slotted to engage the rim of a disc 24' rigid with a pin 35' and a piston 36'. This construction provides means for positively piercing a plug 37' closing the chamber 11^e the said plug being pierced by the action of the explosive gases in the nose 1^a acting on the piston 36'. The disc 24' is thus forced rearwardly against the action of a spring 25' and the barbs 21^b are forced outwardly. The fore part of the body of the projectile is provided with a plurality of recesses 44 through which the inflating gas escapes into the body of the whale. The nose of the projectile is provided with cutting ridges 14^a rigid or integral with the rest of the nose piece which ridges form a pointed fore end for the projectile. In this construction when the projectile strikes each ring 43 shoots forward against the action of the adjacent spring so that the washers 42 spring into the dot and dash position in which position they act as plugs.

In the construction shown in Figure 10 the fore part of the projectile is provided with a plurality of recesses as at 44 to allow of the action of the claws 21^e. The gas container or receptacle is screwed as at 45 to the body 47 of the fore part of the projectile. A tubular part 48 screwed on to the gas container or receptacle 11^h at 46 is inserted into the bore of the forepart. The tubular part 48 has an abutment 50. Surrounding the tubular part 48 is a ring 49 of metal or other suitable material, between which and the abutment 50 on the tubular part 48 is interposed a spring 51. The tubular part 48 is provided with holes 52 which with the ring 49 form a valve so that the inflating gas is released when the ring 49 slides forward when the projectile strikes and/or when the charge in the nose of the

projectile explodes, and escapes into the whale or other mammal through the recesses 44. The ring 49 may be held in the closed position by springs, a shearing device or other suitable means.

In the construction shown in Figure 11 the escape of gas is controlled by a sleeve 53 which is operated by the products of explosion of the explosive charge in the nose of the projectile. The sleeve 53 slides on the tubular part 54, introduced into the bore of the forepart of the projectile. The pivoted claws 21^a also act on opening out on a disc 55 or similar device. A rod 56 or other suitable device is pushed inwards by the effect of the explosion in the nose of the projectile, and the said rod acts on the sleeves 53 thus ensuring positive release of the inflating gas which escapes through a hole 57 or holes in the tubular part 54 and a slot or openings 58 in the sleeve 53 and then through the openings 44', and slots 44 into the body of the whale. The sleeve 53 may be held in the closed position when the projectile is fired and during flight by suitable means.

The disc 55 is prevented from sliding rearwards by a shoulder 56' on the rod 56 so that the rod 56 will be pushed inwards (and thus cause the gas to be liberated) also by the action of the claws 21 when opening out.

Figure 12 shows a section of the rear end of a projectile the inflating gas container or the container which carries the materials from which the inflating gas is evolved being provided with an external screw thread 59 and a tubular extension 60 having holes 61 normally closed by a ring 62 maintained against an abutment 63 on the end of the tubular extension 60 by a spring 64. The plugging member is provided with plugging washers 42^a as in Figure 9 the said washers in Figure 12 being retained in the down position by a sleeve 65 which is provided at its forward end with parts 66 stamped up from or hinged to the sleeve 65 and provided with springs so that when the projectile leaves the muzzle of the gun the members 66 are raised so that they will cause the sleeve to be stripped or shoved off the projectile thereby liberating the washers which by reason of their resiliency rise into the position shown in dot and dash lines and then act to plug up the entry hole. The gas is conducted into the whale body through the holes 66' and cavities 67'.

Figure 13 shows in section a further modified construction of the rear end of a whaling projectile in accordance with the present invention. In this construction the escape of gas from the container or receptacle is controlled by a slidable sleeve 67 which is actuated by the inner ends of pivoted members 68, 69. The latter are turned on their

pivots when the sleeve 65 is stripped or shoved off by the parts 66 engaging the body of the whale and the projecting parts 77 come into contact with the pivoted members 68 and 69. To allow the projecting parts 77 to pass over the projectile grooves 75 may be provided. The parts 66 may be stamped up in the sleeve 65 and be resilient so that they may be pushed into a position flush with the surface of the sleeve 65, when the projectile is in the gun muzzle, but so that they open out as soon as the projectile leaves the muzzle. The sleeve 67 is slotted as at 74 or provided with holes, so that when the slot or holes 74 coincide with the hole, check valve or other suitable arrangement 76 in the tubular extension 78 of the inflating gas-container the said inflating gas thus escapes through the slot or holes and slot and the holes 79 into the body of the whale.

I wish to emphasize that I do not wish to be limited to any special means for starting the generation or the outflow of gas. This generation may be started either by the concussion or impact caused by the firing of the projectile, or by that caused by the object being hit, or by that caused by the explosion of the shell (if any), or by that caused by the disengagement of the plugging member from the body of the projectile, or by the motion of any normally projecting part of the projectile, or by any combination of said and other causes. Finally I wish it to be understood that my improved projectile may be used for catching mammals other than whales and that the term "whaling projectile" should not in any way limit the scope and nature of my invention.

What I claim is:—

1. An inflating projectile provided with means to kill a whale or other mammal and with means to liberate a non-inflammable gas inside the body of the whale which gas is produced in a non-explosive manner, and which subsequently flows into the body of the whale.

2. An inflating whaling projectile provided with a non-inflammable gas container and a plug-member adapted to be separated from the said gas container part of the projectile, and means to liberate gas in a non-explosive manner from the gas container to inflate the whale.

3. An inflating whaling projectile having in combination a chamber filled with a non-inflammable gas in compressed condition, and non-explosive means adapted to liberate in a non-explosive manner the gas confined in the gas chamber which flows into the body of the whale.

4. An inflating whaling projectile formed in two separate parts interconnected by an extensible member, one part forming a container for a non-inflammable gas, the other

- part forming an escape gas preventing plug, means to liberate the non-inflammable gas, and means to permit of the escape of the non-inflammable gas from the container into the body of the whale.
- 5 5. An inflating whaling projectile having in combination a chamber filled with a non-inflammable gas in compressed condition, means to liberate the non-inflammable gas from its container in a non-explosive manner, means to allow of the non-inflammable gas escaping from the container into the body of the whale, and means to prevent the escape of gas used for inflating purposes through the entry hole made by the projectile.
- 10 6. An inflating whaling projectile comprising a compressed gas containing chamber, means to liberate the said gas from the chamber, means to allow of the gas passing from the said chamber into the body of the whale, means to prevent the escape of the non-inflammable gas through the entry hole made by the projectile in the body of the whale, and means to permit of the projectile becoming separated into two parts one part forming a plugging part and the other part carrying the non-inflammable gas into the body of the whale.
- 15 7. An inflating projectile adapted to inflate the body of a whale by a non-inflammable gas or gases liberated therefrom in a non-explosive manner, the said projectile having a plugging up member provided with gripping means and a sleeve covering part of the projectile and adapted on the projectile penetrating the object to be stripped off thereby releasing the plugging up member, and gripping means for holding the said member in position to close the entry hole.
- 20 8. In an inflating projectile as claimed in claim 3, outlet orifices in the non-inflammable gas chamber normally closed by a sleeve and adapted to be uncovered on the sleeve being stripped off so as to allow of the escape of the non-inflammable inflating gas.
- 25 9. In an inflating projectile as claimed in claim 6, said last-mentioned means comprising a coiled metal rod between the projectile body and the plugging member, said rod being adapted, on the plugging member being detached from the projectile body and withheld by its gripping means, to be stretched, thereby producing a resistance for stopping the flight of the projectile body.
- 30 10. In an inflating projectile as claimed in claim 3, means carried by the projectile and adapted on the projectile penetrating the object to be pressed inward, and means adapted to be actuated by the inward movement of the said inwardly movable means to liberate the non-inflammable gas.
- 35 11. An inflating projectile as claimed in claim 3 having means for liberating the confined non-inflammable inflating gas, the said means being adapted to be actuated by inertia.
- 40 12. An inflating projectile as claimed in claim 3 having means for liberating the confined non-inflammable inflating gas, the said means being adapted to be actuated upon the stretching of a coiled metal rod.
- 45 13. An inflating projectile as claimed in claim 3 having means for liberating the confined non-inflammable inflating gas, the said means being adapted to be actuated by the disengagement of the plugging member.
- 50 14. An inflating projectile as claimed in claim 3 having means for liberating the confined non-inflammable inflating gas, the said means being adapted to be actuated by a member displaceably mounted in the projectile body.
- 55 15. An inflating projectile as claimed in claim 1 having means to carry material for the evolution of a non-inflammable gas, means to start chemical action in the said material so as to effect the evolution of the said non-inflammable gas, and means to liberate the evolved non-inflammable gas for the purpose of inflating the whale, the said releasing means being actuated by the stretching of a coiled metal rod.
- 60 16. A projectile adapted to inflate a whale or other mammal on impact therewith or on entry therinto by means of a gas produced non-explosively and also to act as a plug to prevent the escape of the inflating gas liberated from the said projectile through the entry hole.
- 65 17. A projectile adapted to inflate the body of a whale by a gas liberated therefrom in a non-explosive manner, the said projectile having a sleeve adapted to be stripped off on the projectile penetrating the object, a plugging-up member released thereby, and a gripping means similarly released for holding the said member in position to close the entry hole.
- 70 18. An inflating projectile provided with means to kill a whale or other mammal and with means to produce a non-inflammable gas inside the body of the whale, which gas is produced in a non-explosive manner and which subsequently flows into the body of the whale.
- 75 19. An inflating whaling projectile having in combination a chamber provided with means whereby to evolve a non-inflammable gas as the result of chemical action, and non-explosive means adapted to initiate the evolution of the said gas, the said non-explosive means being actuated by a charge contained in the nose of the projectile.
- 80 20. An inflating whaling projectile having in combination a chamber containing gas in a liquefied condition, non-explosive means adapted to expose the liquefied gas to a pres-
- 85
90
95
100
105
110
115
120
125
130

sure approximately equal to that of atmospheric pressure, and means actuated by the explosion of a charge in the nose of the projectile to allow of the gasification of the said liquefied gas.

21. An inflating projectile as claimed in claim 3 having means for liberating the confined non-inflammable inflating gas, the said means being adapted to be actuated by the gases produced as the result of the explosion of a charge in the nose of the projectile.

22. An inflating projectile comprising in combination a nose-piece provided with a charge to kill the whale, a gas container, a connecting piece adapted to couple the nose-piece of the projectile to the gas container, the said connecting piece having in its in-

terior a member adapted to be displaced by the pressure of the gases resulting from the explosion of the charge in the nose of the shell, the said displaceable member being adapted to effect the release of the gas confined in the gas container for the purpose of inflating the body of the whale.

23. A projectile in accordance with claim 21 having means interposed between the connecting piece and the gas container to prevent the escape through the entry hole made by the projectile of the inflating gas liberated from the gas container into the body of the whale.

In testimony whereof I have hereunto signed my name.

AUGUSTUS HENKES.