



- (51) International Patent Classification:  
A61B 5/0408 (2006.01)
- (21) International Application Number:  
PCT/US2017/015035
- (22) International Filing Date:  
26 January 2017 (26.01.2017)
- (25) Filing Language: English
- (26) Publication Language: English
- (30) Priority Data:  
62/287,393 26 January 2016 (26.01.2016) US  
15/415,621 25 January 2017 (25.01.2017) US
- (72) Inventor; and  
(71) Applicant : AXELGAARD, Jens [US/US]; 520 Industrial Way, Fallbrook, California 92028 (US).
- (74) Agent: MARTINO, Marc G.; Hackler Daghighian Martino & Novak, Fourth Floor, 433 N. Camden Drive, Beverly Hills, California 90210 (US).
- (81) Designated States (unless otherwise indicated, for every kind of national protection available): AE, AG, AL, AM,

AO, AT, AU, AZ, BA, BB, BG, BH, BN, BR, BW, BY, BZ, CA, CH, CL, CN, CO, CR, CU, CZ, DE, DJ, DK, DM, DO, DZ, EC, EE, EG, ES, FI, GB, GD, GE, GH, GM, GT, HN, HR, HU, ID, IL, IN, IR, IS, JP, KE, KG, KH, KN, KP, KR, KW, KZ, LA, LC, LK, LR, LS, LU, LY, MA, MD, ME, MG, MK, MN, MW, MX, MY, MZ, NA, NG, NI, NO, NZ, OM, PA, PE, PG, PH, PL, PT, QA, RO, RS, RU, RW, SA, SC, SD, SE, SG, SK, SL, SM, ST, SV, SY, TH, TJ, TM, TN, TR, TT, TZ, UA, UG, US, UZ, VC, VN, ZA, ZM, ZW.

- (84) Designated States (unless otherwise indicated, for every kind of regional protection available): ARIPO (BW, GH, GM, KE, LR, LS, MW, MZ, NA, RW, SD, SL, ST, SZ, TZ, UG, ZM, ZW), Eurasian (AM, AZ, BY, KG, KZ, RU, TJ, TM), European (AL, AT, BE, BG, CH, CY, CZ, DE, DK, EE, ES, FI, FR, GB, GR, HR, HU, IE, IS, IT, LT, LU, LV, MC, MK, MT, NL, NO, PL, PT, RO, RS, SE, SI, SK, SM, TR), OAPI (BF, BJ, CF, CG, CI, CM, GA, GN, GQ, GW, KM, ML, MR, NE, SN, TD, TG).

Published:

— with international search report (Art. 21(3))



WO 2017/132314 A1

(54) Title: DUAL-SIDED ELECTRODE PAD

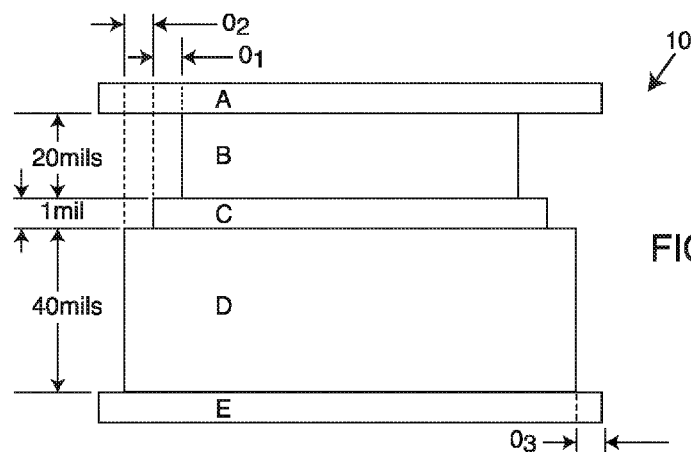

FIG. 1

(57) Abstract: A dual-sided electrode pad assembly is configured to be placed upon a patient's skin and includes an upper conductive gel layer, a middle conductive layer comprising a highly conductive foil, a highly conductive plastic film or a gel with suspended highly conductive particles, and a lower conductive gel layer. The upper and lower conductive gel layer comprise hydrogel, silicone or hydrocolloid. A removable upper and lower protective liner are disposed on the upper and lower conductive gel layers, wherein the upper and lower protective liners are larger in surface area in comparison to the upper conductive gel layer, the middle highly conductive layer and the lower conductive gel layer. The middle highly conductive layer may be smaller in surface area in comparison to the upper and lower conductive gel layers allowing a perimeter edge of the upper and lower conductive gel layers to be disposed past a perimeter edge of the middle highly conductive layer.

## **DUAL-SIDED ELECTRODE PAD**

### **CROSS-REFERENCE TO RELATED APPLICATIONS**

[Para 1] This PCT international application claims priority to U.S. Patent Application No. 15/415,621 filed January 25, 2017, which claims priority to U.S. Provisional Application No. 62/287,393 filed January 26, 2016, the entire contents of which are hereby incorporated by reference.

### **DESCRIPTION:**

#### **FIELD OF THE INVENTION**

[Para 2] The present invention generally relates to electrodes. More particularly, the present invention relates to a dual-sided electrode pad.

#### **BACKGROUND OF THE INVENTION**

[Para 3] In the prior art an ELECTRICAL STIMULATION ELECTRODE was taught in U.S. Patent 6,438,428 issued on August 20, 2002, the contents of which are fully incorporated in full herein with this reference. Referring now to FIG. 4, it showed an exploded view of an electrical pad 40. Each conductive pad 40 included a cover electrically conductive gel adhesive layer 42, a current controlling media 50 and a base electrically conductive gel adhesive layer 56. As you can see in FIG. 4, all of these layers ended at the same perimeter location. These electrodes 40 are typically used with a garment or brace that helps hold the electrodes 40 into place, as is taught in the '428 patent. When the electrodes 40 are not in use, they may be stored for later use. A problem with this design is that the edge of layer 50 may come into contact with skin of the user/patient during use. This may then lead to localized heating or undesirable hot spots.

[Para 4] Then, in the prior art a COMPRESS GARMENT FACILITATING THE USE OF MEDICAL ELECTRODES was taught in U.S. Patent 6,571,115 issued on May 27, 2003, the contents of which are fully incorporated herein with this reference. Referring now to FIG. 14, it showed how the current controlling media no longer came to an edge, but rather had a border section disposed around the perimeter.

This then eliminated localized heating and undesirable hot spots because there was a perimeter border area of low conductivity for the current controlling media layer. However, this resulted in an expensive electrode construction due to the added printing of a conductive pattern.

**[Para 5]** Accordingly, there is a need for an improved electrode that overcomes the drawbacks of the prior art. The present invention fulfills these needs and provides other related advantages.

## SUMMARY OF THE INVENTION

**[Para 6]** An exemplary embodiment of the present invention is a dual-sided electrode pad assembly configured to be placed upon a patient's skin, the dual-sided electrode pad assembly comprising: an upper conductive gel layer; a middle conductive layer comprising a metallic foil layer, a graphite layer or any highly conductive current distribution media; and a lower conductive gel layer; wherein the middle conductive layer is disposed between the upper and lower conductive gel layers.

**[Para 7]** In other exemplary embodiments, the upper conductive gel layer may be 5 to 50 mils thick, or the upper conductive gel layer may typically be approximately 20 mils thick. The upper conductive gel layer may comprise hydrogel, silicone or hydrocolloid.

**[Para 8]** In other exemplary embodiments, the middle conductive layer may be 0.1 to 10 mils thick, or the middle conductive layer may typically be approximately 1 mil thick. The middle highly conductive foil layer may comprise aluminum, tin, graphite, graphene or any highly conductive material.

**[Para 9]** In other exemplary embodiments, the lower conductive gel layer may be 20 to 120 mils thick, or the lower conductive gel layer may typically be 40 mils thick. The lower conductive gel layer may comprise hydrogel, silicone or hydrocolloid.

**[Para 10]** In other exemplary embodiments, a removable upper protective liner may be disposed on the upper conductive gel layer, wherein the upper protective liner is larger in surface area in comparison to the upper conductive gel layer, the middle conductive layer and the lower conductive gel layer. Furthermore, a removable lower protective liner may be disposed on the lower conductive gel layer, wherein the lower protective liner is larger in surface area in comparison to the upper conductive gel layer, the middle conductive layer and the lower conductive gel layer.

**[Para 11]** In other exemplary embodiments, the upper conductive gel layer may be smaller in surface area in comparison to the middle conductive layer allowing a perimeter edge of the middle conductive layer to be disposed past an edge of the upper conductive gel layer. The lower conductive gel layer may be larger in surface area in comparison to the middle conductive layer allowing a perimeter edge of the

lower conductive gel layer to be disposed past the perimeter edge of the middle conductive layer.

**[Para 12]** In other exemplary embodiments, the upper conductive gel layer and the middle conductive layer generally may have the same size of surface area, and wherein the lower conductive gel layer is larger in surface area in comparison to the upper conductive gel layer and the middle conductive layer allowing a perimeter edge of the lower conductive gel layer to be disposed past an edge of the upper conductive gel layer and the middle conductive layer.

**[Para 13]** In other exemplary embodiments, the middle conductive layer may be smaller in surface area in comparison to the upper and lower conductive gel layers allowing a perimeter edge of the upper and lower conductive gel layers to be disposed past a perimeter edge of the middle conductive layer.

**[Para 14]** In other exemplary embodiments, the middle conductive layer may comprise an indicia. The indicia may be embossed into the middle conductive layer. The indicia may be laser etched onto the middle conductive layer. The indicia may be printed onto the middle conductive layer.

**[Para 15]** In other exemplary embodiments, the middle conductive layer may comprise a plurality of individual middle conductive layers disposed between the upper and lower conductive gel layers.

**[Para 16]** In other exemplary embodiments, at least one cutout may be formed in the middle conductive layer. The at least one cutout may be formed in either the upper or lower conductive gel layers. The at least one cutout may similarly be formed in the upper conductive gel layer, the middle conductive layer and the lower conductive gel layer. The cutout may comprise the shape of a circle, square, rectangle, triangle, oval, ellipse, quatrefoil, curvilinear triangle, trapezoid, rhombus, kite, pentagon, hexagon, heptagon, octagon, nonagon, decagon, parallelogram or crescent.

**[Para 17]** In other exemplary embodiments, the electrode may include at least one ink pattern disposed on the middle conductive layer, wherein the at least one ink pattern comprises a higher resistivity in comparison to the middle conductive layer. In another embodiment the conductive foil or the conductive plastic film may comprise at least two materials with differing resistivities. Alternatively, the suspended conductive particles of the gel layer may comprise at least two materials

with differing resistivities. As can be seen, these are all embodiments of structures which can be used to control current distribution in the present invention.

## BRIEF DESCRIPTION OF THE DRAWINGS

[Para 18] The accompanying drawings illustrate the invention. In such drawings:

[Para 19] FIGURE 1 is a sectional view through an exemplary electrode of the present invention;

[Para 20] FIGURE 2 is a sectional view through another exemplary electrode of the present invention;

[Para 21] FIGURE 3 is a sectional view through yet another exemplary electrode of the present invention;

[Para 22] FIGURE 4 is a perspective view of layer C with an embossed indicia;

[Para 23] FIGURE 5 is an perspective view of both sides of layer C with either laser etched or printed indicia;

[Para 24] FIGURE 6 is a sectional view of the exemplary electrode of FIG. 3 now placed upon a patient;

[Para 25] FIGURE 7 is an perspective view of an exemplary electrode of the present invention placed upon a patient's forearm;

[Para 26] FIGURE 8 is similar to FIG. 7, now showing multiple electrodes placed upon a patient's forearm with probes to selectively activate certain electrodes;

[Para 27] FIGURE 9 is a perspective view of the electrodes of the present invention in the stimulating and non-stimulating states;

[Para 28] FIGURE 10 is a top view of another embodiment of the present invention showing the electrode can include a multitude of sections and also include a cutout; and

[Para 29] FIGURE 11 is a top view of yet another embodiment of the present invention showing the electrode can include a multitude of sections and cutouts of varying sizes and shapes.

## DETAILED DESCRIPTION OF THE PREFERRED EMBODIMENTS

**[Para 30]** FIGURE 1 is a cross-sectional view of a new embodiment of a dual-sided electrode pad assembly 10 of the present invention. FIG. 1 is not drawn to scale, but rather is drawn substantially thicker for simplicity to convey the concepts and teachings of the present invention.

**[Para 31]** Layer A is a protective liner that is removed before the electrode itself is utilized. Layer A is significantly oversized in its surface area (i.e. its diameter or width of the electrode) such that it extends beyond the other active layers B, C, and D. This allows easy removal of layer A when the electrode itself is to be used. Layer A is typically a translucent blue silicone liner of medium-density polyethylene at 2-3 mils thick.

**[Para 32]** Layer E is also a protective liner that is removed before the electrode itself is used. Layer E may be made from polyester (Mylar) or other suitable liner materials known to those skilled in the art. Layer E is also oversized, normally 2-5 mils thick, making it easy to place the silicone coated film on the skin-side gel when the electrode 10 is not in use. The Mylar is usually colored or printed with instructions in a manner making it visible should it fall on the floor thus preventing falls in the slippery silicone.

**[Para 33]** Layers A and E protect the electrode 10 during shipping and storage. Layers A and E also prevent dust, particles and other contaminants from dirtying the electrode 10. Also, layers A and E prevent the adhesive gels B and D from sticking to other objects. Layers A and E help prevent the electrode 10 from drying out as layers B and D are typically conductive hydrogel layers which could dry out if left uncovered. Therefore, even after the electrode 10 itself is used, layers A and E can be reused to further protect the electrode 10 until the electrodes next usage.

**[Para 34]** Layers B and D are conductive gels. In this embodiment layer B is about 20 mils thick, but can be made within a range of 5-50 mils thick. Layer D is about 40 mils thick, but can be made in a range of 20-120 mils thick. The conductive gels for layers B and D may be made from any conductive adhesive such as hydrogel, silicone, hydrocolloid, etc. as an example. See prior art MEDICAL ELECTRODE as taught in U.S. patent 7,346,380 issued on March 18, 2008, which is incorporated in full herein with this reference.

**[Para 35]** In the prior art patent 6,571,115, the current controlling media 50 was a printed carbon film which was expensive to produce. In the present invention, layer C is a conductive metallic foil, a graphite layer or any other highly conductive media. The thickness of layer C can be around 1 mils, or in a range of 0.1-10 mils. The use of a 1 mil aluminum foil in layer C significantly reduces the cost of the overall electrode assembly 10.

**[Para 36]** As can be seen in FIG. 1, layer B is smaller in surface area (i.e. its diameter or width/length across the electrode) in comparison to layer C, which can be seen in the oversize one dimension ( $O_1$ ). Then layer C is smaller in surface area in comparison to layer D, which can be seen in the oversize two dimension ( $O_2$ ). Also, layers A and E are oversized in comparison to layers B, C and D, which can be seen in the oversize three dimension ( $O_3$ ). In this embodiment, the differing surface areas of the active layers prevents and/or reduces the chance of edge burning or undesirable localized heating. The B layer may be of any size smaller than the C layer ( $O_1$ ) while the D layer preferably is  $\frac{1}{4}$ " larger along the edge than the C layer but may be in an oversize range of  $\frac{1}{8}$ " to  $\frac{5}{8}$ " ( $O_2$ ). The A and E layers in one embodiment may be  $\frac{1}{4}$ " or longer ( $O_3$ ) than the D layer, but may be a minimum oversize equal to or greater than  $\frac{1}{8}$ ".

**[Para 37]** As shown in FIG. 1, layer B is smaller in surface area in comparison to layers C and D. However, in other embodiments layer B may be the same size as layer C, where then layer D is oversized ( $O_4$ ) in comparison to layers B and C. This embodiment is best shown in FIGURE 2.

**[Para 38]** Alternatively, layer B may be the same size (surface area) as layer D, where now layers B and D are oversized ( $O_5$ ) in comparison to layer C. This embodiment is best shown in FIGURE 3. In all of these embodiments, the chance of edge burning or undesirable localized heating is either reduced and/or eliminated.

**[Para 39]** FIG. 3 also teaches a significant advantage in safety for use of the electrode 10. In some situations, the electrode may be placed upside-down by the user/patient. This may occur through unintentional error during use, as one may be fatigued or not paying close attention. FIG. 3 shows that both layers B and D are oversized in comparison to layer C. This unique structure then allows the electrode in FIG. 3 to be placed upside-down and still not create hot spots or undesirable localized heating.

**[Para 40]** As can be understood and seen in FIG. 1-3, it is no longer needed that a printed carbon film with an unprinted border be used. Rather now, a conductive foil can be used instead, such a metallic foil, a graphite foil or any other highly conductive cheaper media can be used. For example a conductive plastic film layer can be used herein with the present invention. Furthermore, a hydrogel layer may be used wherein the hydrogel layer comprises a suspended metal, graphite, graphene or other highly conductive particles. The conductive particles can not only be suspended in hydrogel but also in a silicone or hydrocolloid gel layer.

**[Para 41]** Referring now to FIGURE 4, in another embodiment it is possible to emboss layer C with various indicia 12 that may be useful to the user or the manufacturer. For example, layer C may be embossed with a logo or trademark 12 to help identify the manufacturer of the electrode. Or, layer C may be embossed with various directions that help the user utilize the electrode 10. In another embodiment, embossing layer C may be done when layer C has a thickness of around 1 mil, but it is also possible to emboss other thicknesses. It is possible to see such embossed structures because it is typical that layers B and/or D are at least partially optically transparent such that a user can see what is embossed on layer C.

**[Para 42]** It is also possible that during the step for embossing, that the layer C can be cutout 14 at the same time. For example, in manufacturing the embossing step 12 and cutout step 14 can be one after the other, or done at the same time to speed up the manufacturing process.

**[Para 43]** Referring now to FIGURE 5, in another embodiment it is possible to laser etch various indicia 16 into the layer C. Laser etching can produce very accurate and detailed information 16. Again, various logos or directions can be laser etched directly onto layer C.

**[Para 44]** In another embodiment, it is possible to print various indicia 18 onto layer C. Printing can also produce very accurate and detailed information.

**[Para 45]** As an example of the present invention, when layer C is changed from a carbon film at \$0.70/LnFt (linear foot) to now \$0.02/LnFt for an aluminum foil, a substantial reduction in cost is achieved (a factor 35). This change in material combined with a new oversized configuration taught in FIGS. 1-3 is a significant improvement over the prior art.

**[Para 46]** Referring now to FIGURES 6 and 7 it is also important to understand that the embodiments of the present invention can be used with a garment or brace as in the prior art, but can also be utilized without such garment or braces. For example, the electrode 10 of the present invention can be utilized with any electrical connection means 20 that conducts electrical signals to layer B, which then conducts through layers C and D and finally to the skin 22 of the user/patient. Therefore, the use of a garment or brace is not required to practice the embodiments of the present invention taught herein.

**[Para 47]** FIG. 7 shows the electrode 10 in a more realistic perspective view placed upon a forearm 24 of the user/patient.

**[Para 48]** Referring now to FIGURE 8, a plurality of dual-sided electrodes 10 may be placed on the skin by a physical therapist, as seen in the upper forearm location where the B and D layers are oversized in comparison to the C layer. As also shown in FIG. 8 near the wrist, a substantially large B and D layer contains a plurality of smaller C layers in between. As can be seen in FIG. 8, with reference to FIGS. 1-3, there are a multitude of ways the present invention can be configured into varying types of electrodes. It is then understood by those skilled in the art that any of the electrode embodiments taught herein (FIGS. 1-3) may be used in the above described methods.

**[Para 49]** Typically for muscle stimulation, two electrode locations are used to elicit proper muscle contractions for muscles in-between these electrode locations when stimulated. For example one probe 26 may activate an electrode on the upper forearm whereas a second probe 26 may activate an electrode near the wrist. Therefore, the two probes 26 can then be used to activate certain muscles for stimulation. By moving the two probes 26 from electrode pair to electrode pair, the practitioner may quickly and accurately by comparison determine the optimum permanent electrode placements for then the actual treatment electrodes. This is similar in concept to FIG. 6 of U.S. patent 5,904,712 issued on May 18, 1999 and FIG. 6 of U.S. patent 6,038,485 issued on March 14, 2000, the contents of which are fully incorporated herein with this references.

**[Para 50]** To better help the reader understand how the electrodes work in practice, one is referred to FIG. 7 of U.S. patent 8,473,072 issued on June 25, 2013 and U.S. patent 8,874,231 issued on October 28, 2014, the contents of which are

fully incorporated herein with this references. This is also shown herein in the present invention as FIGURE 9. FIGURE 9 is a perspective view of an electrode 10 attached to the forearm 24 of a patient. In the upper view the electrode is in an off state and is not transmitting any electrical signals. The hand of the patents is shown in a closed state. The lower view shows the electrode in an activated state and accordingly the hand of the patient is open. As can be understood by those skilled in the art, the electrode 10 can be configured to be placed along any other body part of the patient.

**[Para 51]** The present invention can also be designed to incorporate various cutouts or voids that can be formed in any of the layers B, C or D. For example, FIGURE 10 illustrates a view similar to that of FIG. 9 in U.S. Patent Publication 2007/0238944, the contents of which are fully incorporated herein. FIG. 10 is a top view of another embodiment of an electrode 10 of the present invention where a cutout 28 is formed between four separately controlled electrodes. FIGURE 11 of the present invention is also similar to FIG. 8 of the '944 patent publication. FIG. 11 shows that various cutouts 28 can be utilized. For example, a large rectangular cutout 28 can separate two electrode portions. Alternatively, a multitude of differently shaped cutouts 28 can include circles, hexagons, triangles, squares, half-circles and the like. As can be appreciated by those skilled in the art, the present invention can be utilized in many of the ways the prior art electrodes have been utilized however now at a cheaper manufacturing cost.

**[Para 52]** It is understood herein that the cutouts 28 or voids 28 in any of the layers B, C or D can be used to control the conductivity/resistivity of any such layer. For example, to better control the current distribution in layer C, cutouts formed in layer C can be used. Alternatively, layer C may be screen printed or flood coated with various non-conductive inks 28 or with inks 28 having a higher resistivity than layer C. The cutouts 28 were a mechanical mechanism to control current distribution whereas the use of less conductive inks 28 is more of an electrical mechanism for controlling current distribution.

**[Para 53]** In efforts to achieve more control over the current distribution through layer C, it is possible to use two (or more) materials with differing resistivity. For example, layer C could comprise a graphite foil selectively cut and placed adjacently to an aluminum or tin foil. The graphite is more resistive in comparison to either

aluminum or tin. Likewise, when the C layer is a gel layer with suspended conductive particles, two differing materials of conductive particles could be used. For example, particles of graphite may be used in one location whereas particles of aluminum or tin could be used elsewhere. In this manner the current distribution through the layer C can better be controlled while still resulting in a cheaper and simpler alternative to the prior art electrodes.

**[Para 54]** It is also to be understood that the electrodes 10 of the present invention can be made in varying shapes, including but not limited to, circles, squares, rectangles, triangles, ovals, ellipses, quatrefoils, curvilinear triangles, trapezoids, rhombuses, kites, pentagons, hexagons, heptagons, octagons, nonagons, decagons, parallelograms, crescents and any other shape possible as this disclosure is not limited to the shapes shown herein.

**[Para 55]** It is also to be understood that in the present invention the layer C is a highly conductive layer whereas layers B and D are conductive. In other words, layer C is a layer which has a higher conductivity in comparison to layers B or D. It is also typical that gels and conductive foils are measured differently for resistivity, in that a foil is measured in a surface resistance whereas a gel is measured in a volume resistivity. In general the B layer and D layer will have a volume resistivity greater than 100 ohm-cm and the C layer will have a surface resistivity less than 10 ohms. As can be seen, layer C is a highly conductive layer in comparison to layers B and D.

**[Para 56]** As one example of the present invention, the following measurements are applicable:

Layer B, USB35 gel, thickness 35 mils, volume resistivity 1233 ohm-cm, surface resistivity 6500;

Layer D, USS35 gel, thickness 34 mils, volume resistivity 1450 ohm-cm, surface resistivity 8600;

Layer C, graphite, thickness 5 mils, surface resistivity 4 ohm;

Layer C, aluminum, thickness 5 mils, surface resistivity 0.22 ohm;

Layer C, tin, thickness 2.5 mils, surface resistivity 0.08 ohm.

**[Para 57]** For further information, one is referred to U.S. patent 7,769,473 issued on August 3, 2010, the contents of which are fully incorporated herein with this reference.

**[Para 58]** For further information, one is referred to U.S. patent 6,038,464 issued on March 14, 2000, the contents of which are fully incorporated herein with this reference.

**[Para 59]** As used herein a mil is one thousandth of an inch, which is 0.001 of an inch.

**[Para 60]** Although several embodiments have been described in detail for purposes of illustration, various modifications may be made to each without departing from the scope and spirit of the invention. Accordingly, the invention is not to be limited, except as by the appended claims.

**What is claimed is:**

**[Claim 1]** A dual-sided electrode pad assembly configured to be placed upon a patient's skin, the dual-sided electrode pad assembly comprising:

an upper conductive gel layer having a volume resistivity greater than 100 ohm-cm;

a middle conductive layer having a surface resistivity less than 10 ohms; and

a lower conductive gel layer having a volume resistivity greater than 100 ohm-cm;

wherein the middle conductive layer is disposed between the upper and lower conductive gel layers.

**[Claim 2]** The dual-sided electrode pad assembly of claim 1, wherein the middle conductive layer comprises a conductive foil, a conductive plastic film or a gel layer with suspended conductive particle.

**[Claim 3]** The dual-sided electrode pad assembly of claim 1, wherein the upper conductive gel layer is 5 to 50 mils thick.

**[Claim 4]** The dual-sided electrode pad assembly of claim 1, wherein the upper conductive gel layer is approximately 20 mils thick.

**[Claim 5]** The dual-sided electrode pad assembly of claim 1, wherein the upper conductive gel layer comprises hydrogel, silicone or hydrocolloid.

**[Claim 6]** The dual-sided electrode pad assembly of claim 1, wherein the middle conductive layer is 0.1 to 10 mils thick.

**[Claim 7]** The dual-sided electrode pad assembly of claim 1, wherein the middle conductive layer is approximately 1 mil thick.

**[Claim 8]** The dual-sided electrode pad assembly of claim 1, wherein the conductive foil of the middle conductive layer comprises a metallic foil or a graphite foil.

**[Claim 9]** The dual-sided electrode pad assembly of claim 1, wherein the suspended conductive particles in the gel layer of the middle conductive layer comprise metal particles, graphite particles or graphene particles.

**[Claim 10]** The dual-sided electrode pad assembly of claim 1, wherein the lower conductive gel layer is 20 to 120 mils thick.

**[Claim 11]** The dual-sided electrode pad assembly of claim 1, wherein the lower conductive gel layer is 40 mils thick.

**[Claim 12]** The dual-sided electrode pad assembly of claim 1, wherein the lower conductive gel layer comprises hydrogel, silicone or hydrocolloid.

**[Claim 13]** The dual-sided electrode pad assembly of claim 1, including a removable upper protective liner disposed on the upper conductive gel layer, wherein the upper protective liner is larger in surface area in comparison to the upper conductive gel layer, the middle conductive layer and the lower conductive gel layer.

**[Claim 14]** The dual-sided electrode pad assembly of claim 1, including a removable lower protective liner disposed on the lower conductive gel layer, wherein the lower protective liner is larger in surface area in comparison to the upper conductive gel layer, the middle conductive layer and the lower conductive gel layer.

**[Claim 15]** The dual-sided electrode pad assembly of claim 1, wherein the upper conductive gel layer is smaller in surface area in comparison to the middle conductive layer allowing a perimeter edge of the middle conductive layer to be disposed past an edge of the upper conductive gel layer.

**[Claim 16]** The dual-sided electrode pad assembly of claim 15, wherein the lower conductive gel layer is larger in surface area in comparison to the middle conductive layer allowing a perimeter edge of the lower conductive gel layer to be disposed past the perimeter edge of the middle conductive layer.

**[Claim 17]** The dual-sided electrode pad assembly of claim 1, wherein the upper conductive gel layer and the middle conductive layer generally have the same size of surface area, and wherein the lower conductive gel layer is larger in surface area in comparison to the upper conductive gel layer and the middle conductive layer allowing a perimeter edge of the lower conductive gel layer to be disposed past an edge of the upper conductive gel layer and the middle conductive layer.

**[Claim 18]** The dual-sided electrode pad assembly of claim 1, wherein the middle conductive layer is smaller in surface area in comparison to the upper and lower conductive gel layers allowing a perimeter edge of the upper and lower conductive gel layers to be disposed past a perimeter edge of the middle conductive layer.

**[Claim 19]** The dual-sided electrode pad assembly of claim 1, wherein the middle conductive layer comprises an indicia.

**[Claim 20]** The dual-sided electrode pad assembly of claim 19, wherein the indicia is embossed into the middle conductive layer.

**[Claim 21]** The dual-sided electrode pad assembly of claim 19, wherein the indicia is laser etched onto the middle conductive layer.

**[Claim 22]** The dual-sided electrode pad assembly of claim 19, wherein the indicia is printed onto the middle conductive layer.

**[Claim 23]** The dual-sided electrode pad assembly of claim 1, wherein the middle conductive layer comprises a plurality of individual middle conductive layers disposed between the upper and lower conductive gel layers.

**[Claim 24]** The dual-sided electrode pad assembly of claim 1, including at least one cutout formed in the middle conductive layer.

**[Claim 25]** The dual-sided electrode pad assembly of claim 1, including at least one cutout formed in either the upper or lower conductive gel layers.

**[Claim 26]** The dual-sided electrode pad assembly of claim 1, including at least one cutout similarly formed in the upper conductive gel layer, the middle conductive layer and the lower conductive gel layer.

**[Claim 27]** The dual-sided electrode pad assembly of claim 26, wherein the cutout comprises the shape of a circle, square, rectangle, triangle, oval, ellipse, quatrefoil, curvilinear triangle, trapezoid, rhombus, kite, pentagon, hexagon, heptagon, octagon, nonagon, decagon, parallelogram or crescent.

**[Claim 28]** The dual-sided electrode pad assembly of claim 1, including at least one ink pattern disposed on the middle conductive layer, wherein the at least one ink pattern comprises a higher resistivity in comparison to the middle conductive layer.

**[Claim 29]** The dual-sided electrode pad assembly of claim 2, wherein the conductive foil or the conductive plastic film comprises at least two materials with differing resistivities.

**[Claim 30]** The dual-sided electrode pad assembly of claim 2, wherein the suspended conductive particles of the gel layer comprise at least two materials with differing resistivities.

**[Claim 31]** A dual-sided electrode pad assembly configured to be placed upon a patient's skin, the dual-sided electrode pad assembly comprising:  
    an upper conductive gel layer, wherein the upper conductive gel layer is 5 to 50 mils thick and has a volume resistivity greater than 100 ohm-cm;  
    a middle conductive layer comprising a conductive foil, a conductive plastic film or a gel layer with suspended conductive particles, wherein the middle

conductive layer is 0.1 to 10 mils thick and has a surface resistivity less than 10 ohms;

a lower conductive gel layer, wherein the lower conductive gel layer is 20 to 120 mils thick and has a volume resistivity greater than 100 ohm-cm;

wherein the upper and lower conductive gel layer comprise hydrogel, silicone or hydrocolloid;

a removable upper protective liner disposed on the upper conductive gel layer, wherein the upper protective liner is larger in surface area in comparison to the upper conductive gel layer, the middle conductive layer and the lower conductive gel layer; and

a removable lower protective liner disposed on the lower conductive gel layer, wherein the lower protective liner is larger in surface area in comparison to the upper conductive gel layer, the middle conductive layer and the lower conductive gel layer.

**[Claim 32]** A dual-sided electrode pad assembly configured to be placed upon a patient's skin, the dual-sided electrode pad assembly comprising:

an upper conductive gel layer, wherein the upper conductive gel layer is 5 to 50 mils thick and has a volume resistivity greater than 100 ohm-cm;

a middle conductive layer comprising a conductive foil, a conductive plastic film or a gel layer with suspended conductive particles, wherein the middle conductive layer is 0.1 to 10 mils thick;

a lower conductive gel layer, wherein the lower conductive gel layer is 20 to 120 mils thick and has a volume resistivity greater than 100 ohm-cm;

wherein the upper and lower conductive gel layer comprise hydrogel, silicone or hydrocolloid;

a removable upper protective liner disposed on the upper conductive gel layer, wherein the upper protective liner is larger in surface area in comparison to the upper conductive gel layer, the middle conductive layer and the lower conductive gel layer;

a removable lower protective liner disposed on the lower conductive gel layer, wherein the lower protective liner is larger in surface area in comparison to the upper conductive gel layer, the middle conductive layer and the lower conductive gel layer; and

wherein the middle conductive layer is smaller in surface area in comparison to the upper and lower conductive gel layers allowing a perimeter edge of the upper and lower conductive gel layers to be disposed past a perimeter edge of the middle conductive layer.

**[Claim 33]** A dual-sided electrode pad assembly configured to be placed upon a patient's skin, the dual-sided electrode pad assembly comprising:

an upper conductive gel layer;

a middle conductive layer comprising a conductive foil, a conductive plastic film or a gel layer with suspended conductive particles;

a lower conductive gel layer;

wherein the middle conductive layer is disposed between the upper and lower conductive gel layers.

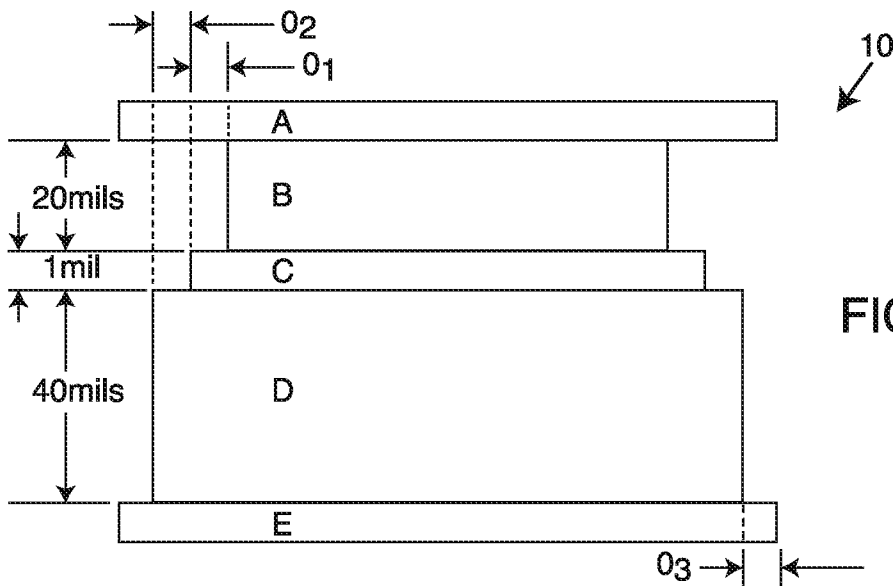

FIG. 1

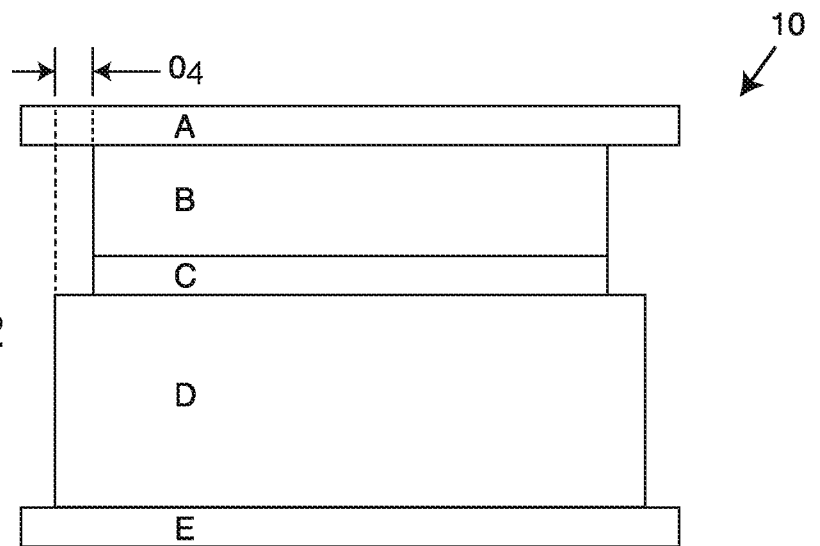

FIG. 2

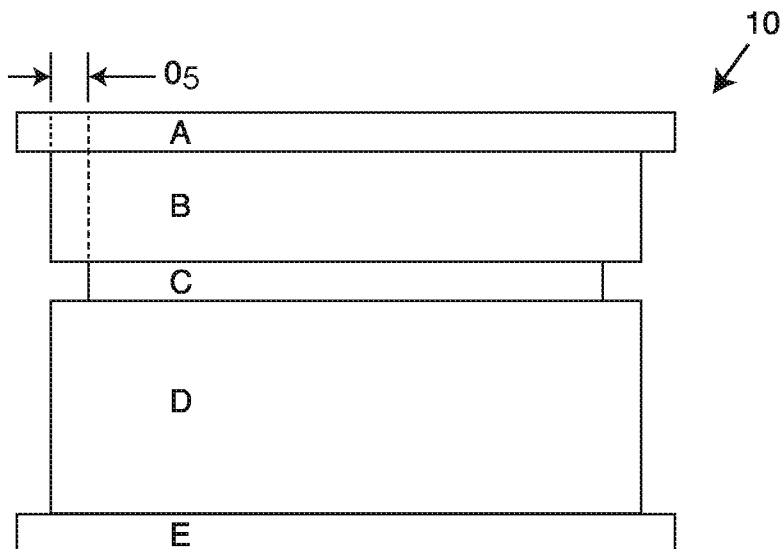

FIG. 3

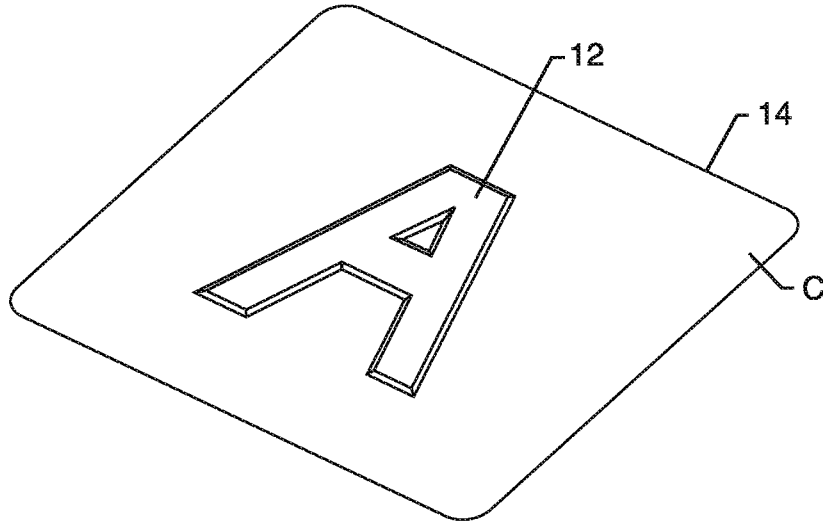

FIG. 4

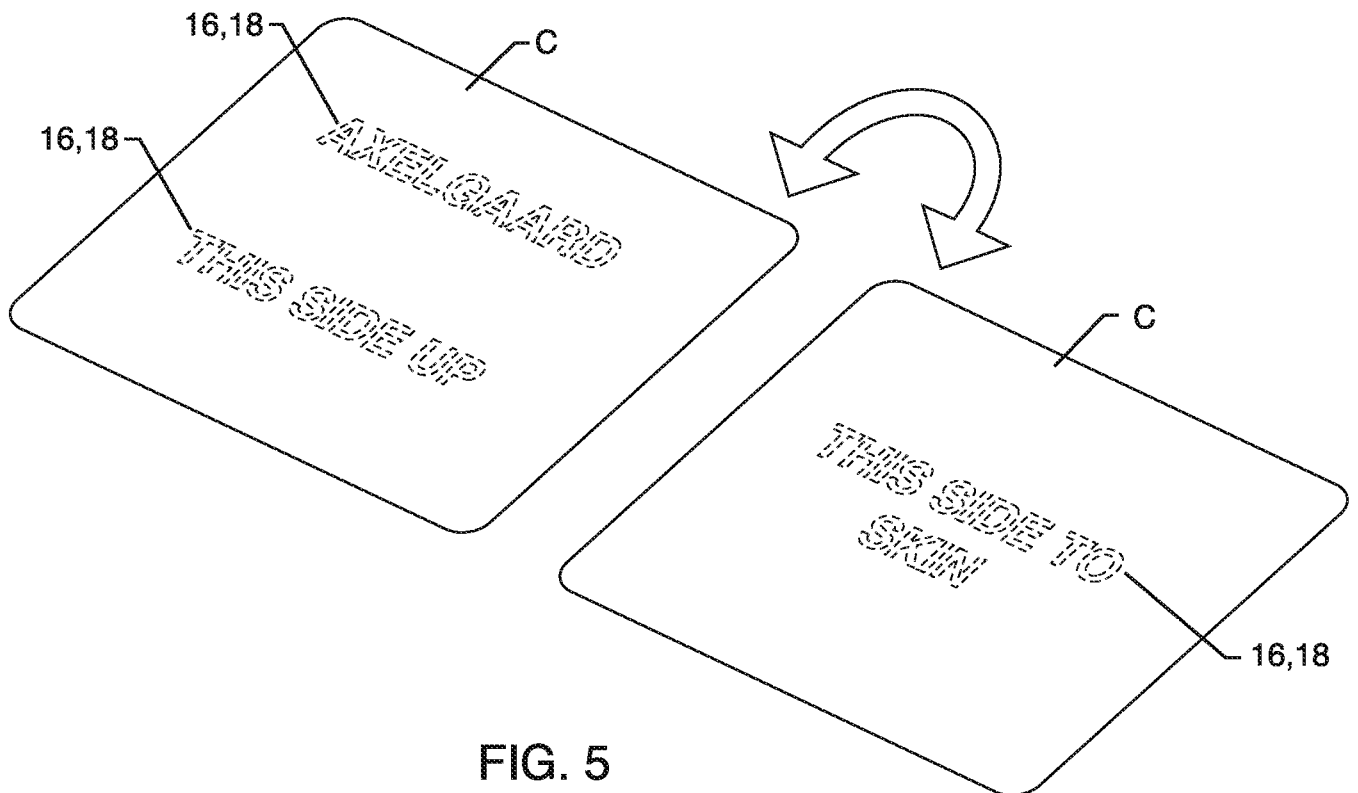

FIG. 5

3 / 6

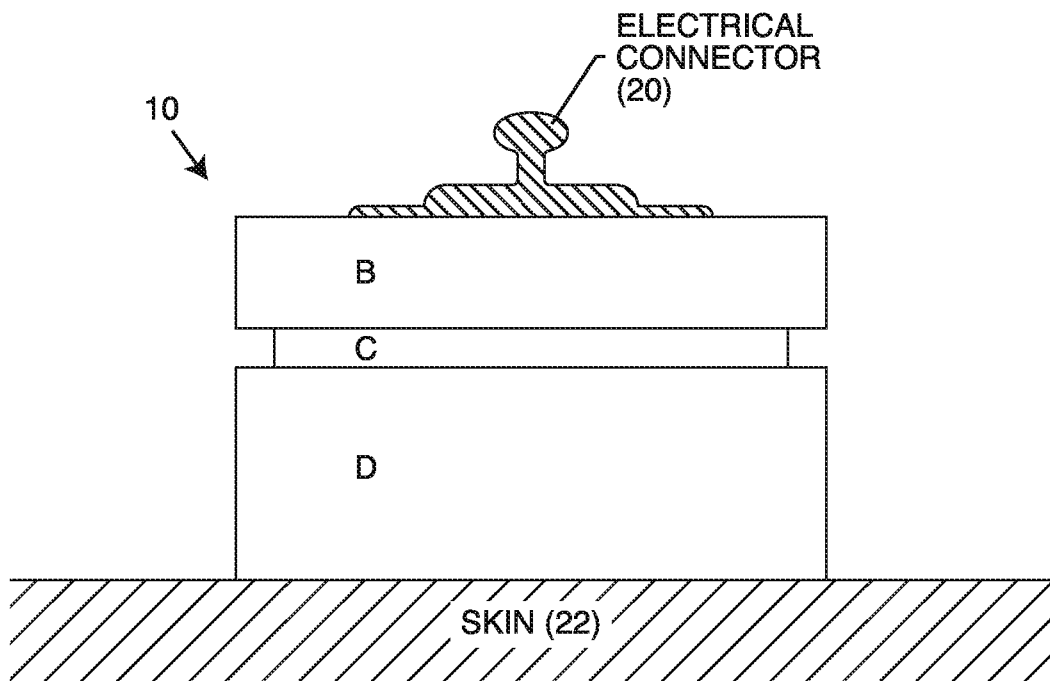

FIG. 6

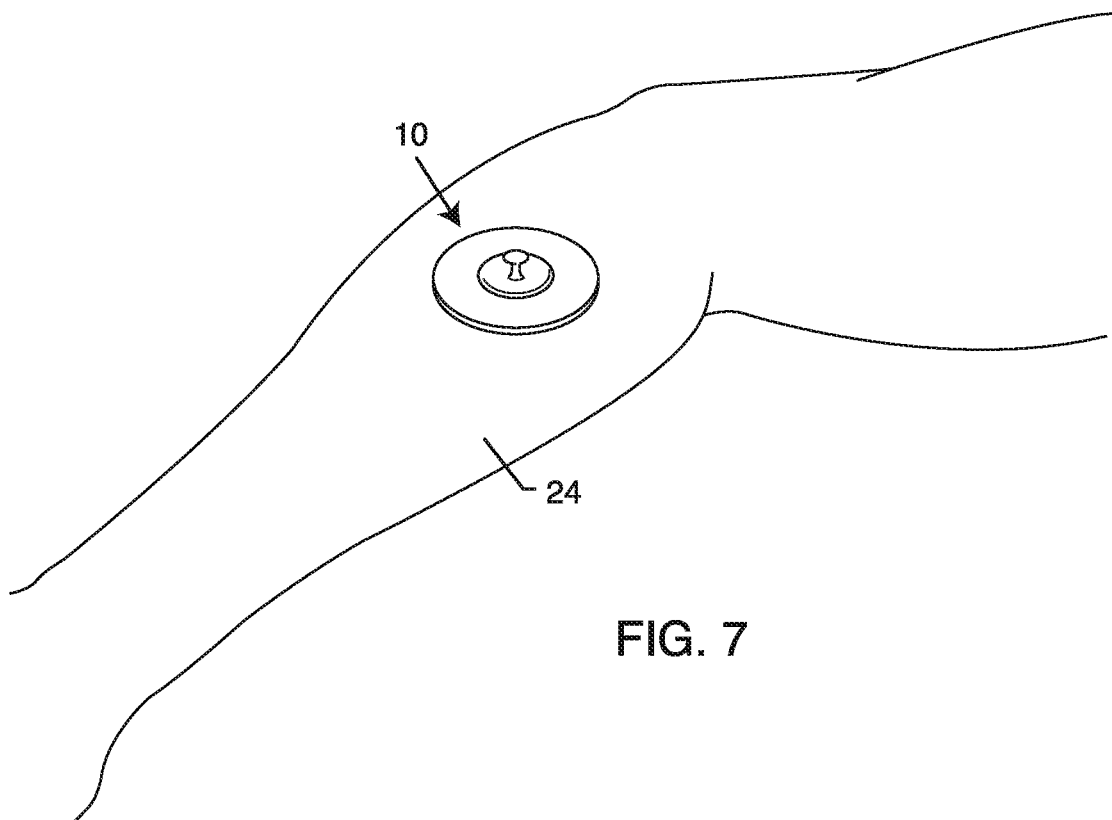
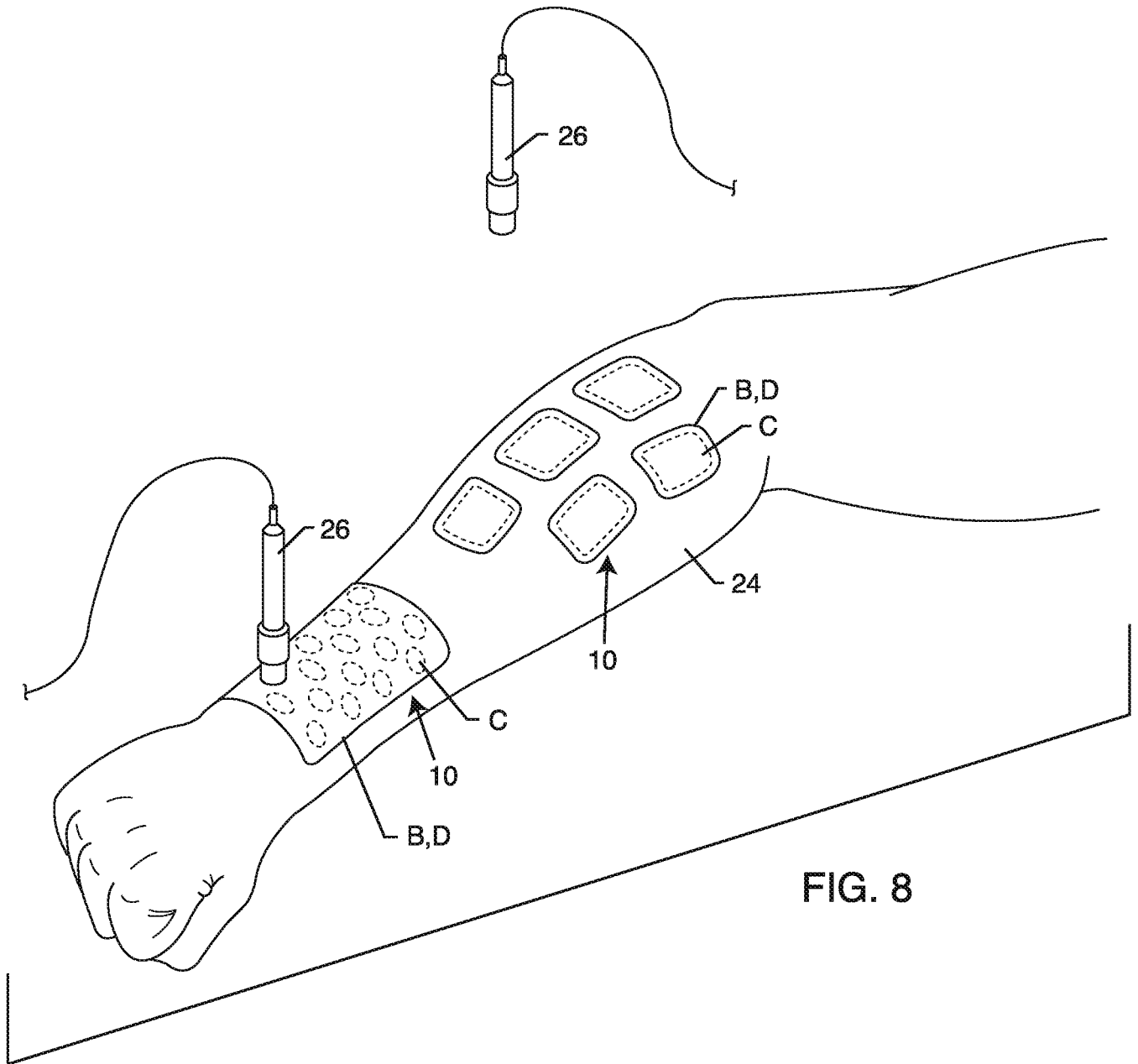

FIG. 7



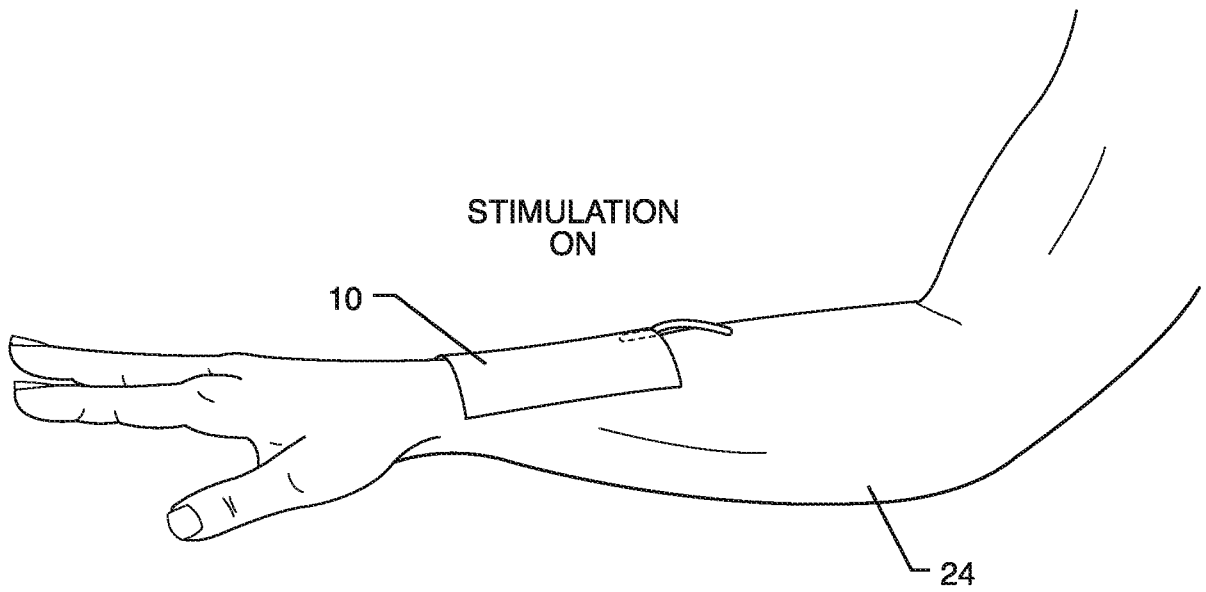
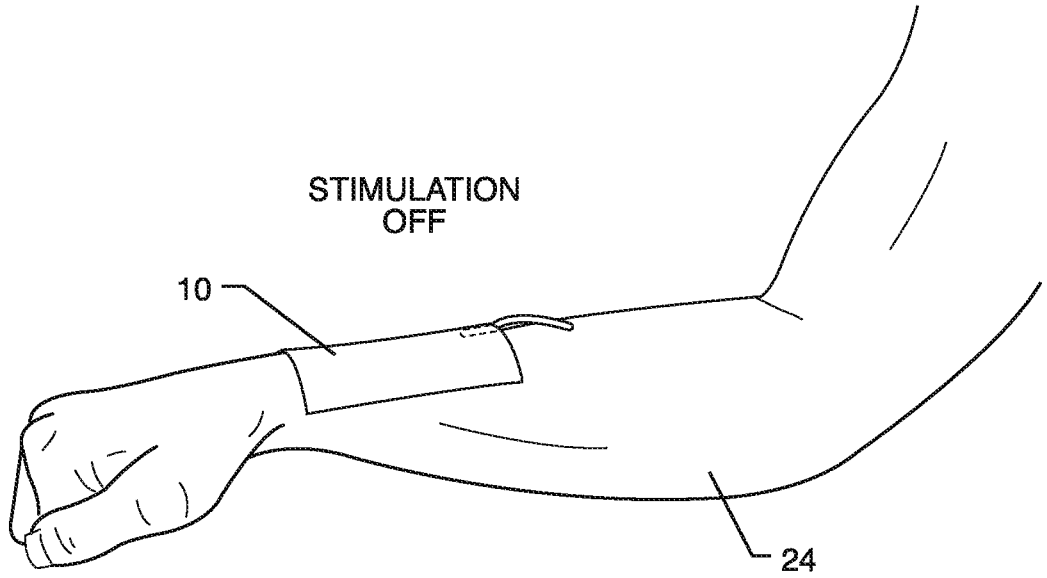

FIG. 9

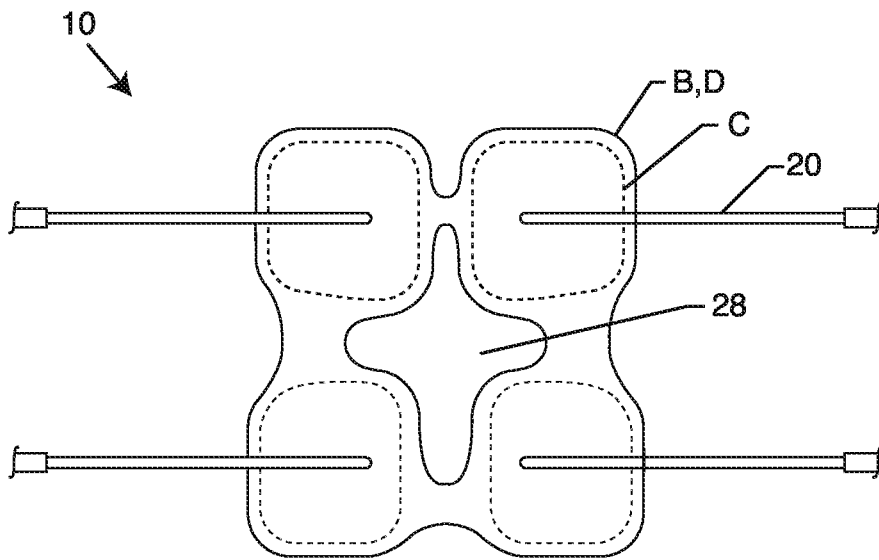

FIG. 10

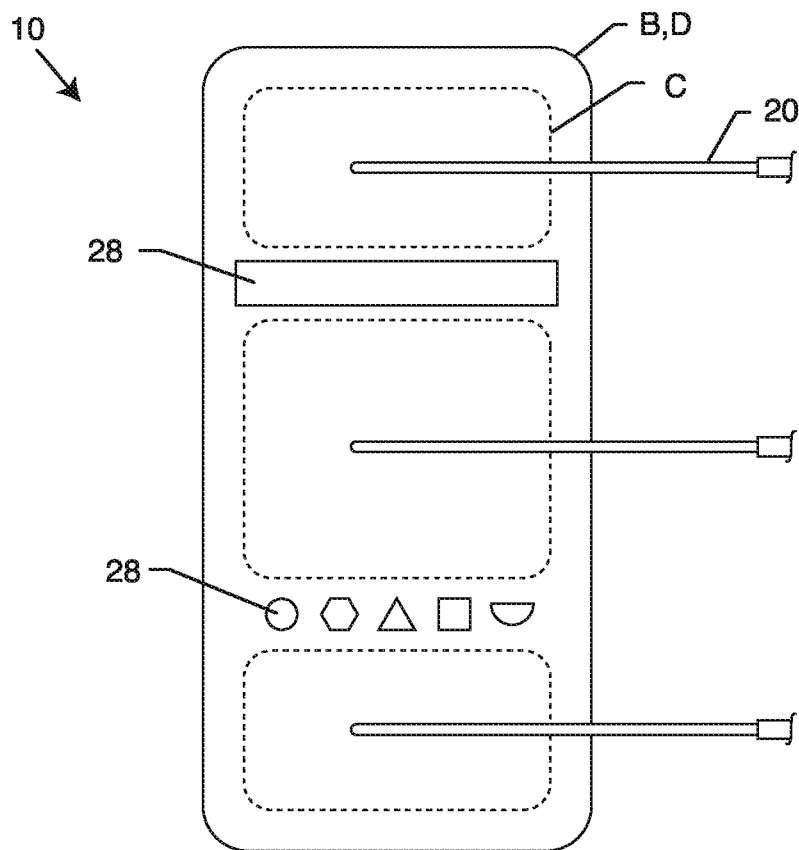

FIG. 11

## INTERNATIONAL SEARCH REPORT

International application No.

PCT/US 17/15035

## A. CLASSIFICATION OF SUBJECT MATTER

IPC(8) - A61B 5/0408 (2017.01)

CPC - A61B 5/04087, A61B 5/0496, A61N 1/0492, A61B 2562/125, A61N 1/0404

According to International Patent Classification (IPC) or to both national classification and IPC

## B. FIELDS SEARCHED

Minimum documentation searched (classification system followed by classification symbols)

See Search History Document

Documentation searched other than minimum documentation to the extent that such documents are included in the fields searched

See Search History Document

Electronic data base consulted during the international search (name of data base and, where practicable, search terms used)

See Search History Document

## C. DOCUMENTS CONSIDERED TO BE RELEVANT

Category*	Citation of document, with indication, where appropriate, of the relevant passages	Relevant to claim No.
X -- Y -- A	US 2002/0156357 A1 (AXELGAARD); 24 October 2002 (24.10.2002); entire document, especially Figs. 1, 2, 4, Abstract, para. [0010], [0031]-[0032], [0045]-[0048].	1-4, 6-7, 10-11, 14, 19, 22-24, 28-29, 33 ----- 13, 25-26 ----- 5, 8-9, 12, 15-18, 20-21, 27, 30-32
Y -- A	US 2005/0015134 A1 (CARIM); 20 January 2005 (20.01.2005); entire document, especially Fig. 1, para. [0034], [0060]-[0061].	13 ----- 5, 8-9, 12, 30-32
Y -- A	US 2007/0238944 A1 (AXELGAARD); 11 October 2007 (11.10.2007); entire document, especially Fig. 7, para. [0056].	25-26 ----- 27
A	US 7,403,807 B2 (Dupelle et al.); 22 July 2008 (22.07.2008); entire document.	1-33
A	US 7,689,285 B2 (GARABET); 30 March 2010 (30.03.2010); entire document.	1-33 ----- 14, 19, ----- 8, 20-21, -----

 Further documents are listed in the continuation of Box C.

* Special categories of cited documents:	"T" later document published after the international filing date or priority date and not in conflict with the application but cited to understand the principle or theory underlying the invention
"A" document defining the general state of the art which is not considered to be of particular relevance	"X" document of particular relevance; the claimed invention cannot be considered novel or cannot be considered to involve an inventive step when the document is taken alone
"E" earlier application or patent but published on or after the international filing date	"Y" document of particular relevance; the claimed invention cannot be considered to involve an inventive step when the document is combined with one or more other such documents, such combination being obvious to a person skilled in the art
"L" document which may throw doubts on priority claim(s) or which is cited to establish the publication date of another citation or other special reason (as specified)	"&" document member of the same patent family
"O" document referring to an oral disclosure, use, exhibition or other means	
"P" document published prior to the international filing date but later than the priority date claimed	

Date of the actual completion of the international search

16 March 2017

Date of mailing of the international search report

20 APR 2017

Name and mailing address of the ISA/US

Mail Stop PCT, Attn: ISA/US, Commissioner for Patents  
P.O. Box 1450, Alexandria, Virginia 22313-1450  
Facsimile No. 571-273-8300

Authorized officer:

Lee W. Young

PCT Helpdesk: 571-272-4300  
PCT OSP: 571-272-7774



(12)发明专利申请

(10)申请公布号 CN 108697359 A

(43)申请公布日 2018.10.23

(21)申请号 201780008350.4

(74)专利代理机构 北京金信知识产权代理有限公司 11225

(22)申请日 2017.01.26

代理人 王智 李海菊

(30)优先权数据

62/287,393 2016.01.26 US

15/415,621 2017.01.25 US

(51)Int.Cl.

A61B 5/0408(2006.01)

(85)PCT国际申请进入国家阶段日

2018.07.26

(86)PCT国际申请的申请数据

PCT/US2017/015035 2017.01.26

(87)PCT国际申请的公布数据

W02017/132314 EN 2017.08.03

(71)申请人 延斯·阿克塞加德

地址 美国加利福尼亚州

(72)发明人 延斯·阿克塞加德

权利要求书3页 说明书6页 附图7页

(54)发明名称

双面电极垫

(57)摘要

一种双面电极垫组件,其被配置为放置在患者的皮肤上,并且包括上导电凝胶层、中间导电层以及下导电凝胶层,中间导电层包括高导电箔、高导电塑料膜或具有悬浮的高导电颗粒的凝胶。上导电凝胶层和下导电凝胶层包括水凝胶、硅树脂或水胶体。可拆卸的上保护衬里和下保护衬里设置在上导电凝胶层和下导电凝胶层上,其中上保护衬里和下保护衬里与上导电凝胶层、中间高导电层和下导电凝胶层相比表面积更大。中间高导电层与上导电凝胶层和下导电凝胶层相比表面积可以更小,从而允许上导电凝胶层和下导电凝胶层的周边边缘设置在中间高导电层的周边边缘之外。

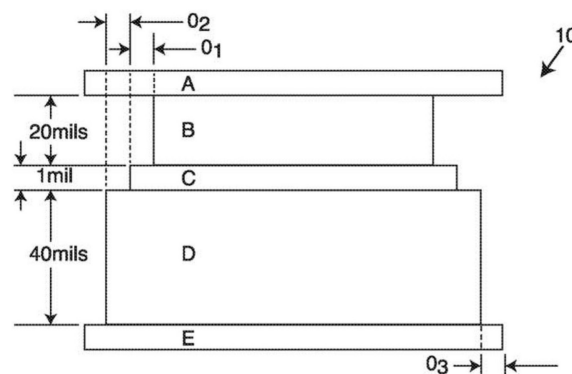

1. 一种双面电极垫组件,配置为放置在患者皮肤上,所述双面电极垫组件包括:  
上导电凝胶层,其体积电阻率大于100欧姆-厘米;  
中间导电层,其表面电阻率小于10欧姆;以及  
下导电凝胶层,其体积电阻率大于100欧姆-厘米;  
其中,所述中间导电层设置在所述上导电凝胶层和所述下导电凝胶层之间。
2. 根据权利要求1所述的双面电极垫组件,其中所述中间导电层包括导电箔、导电塑料膜或具有悬浮的导电颗粒的凝胶层。
3. 根据权利要求1所述的双面电极垫组件,其中所述上导电凝胶层的厚度为5至50密耳。
4. 根据权利要求1所述的双面电极垫组件,其中所述上导电凝胶层的厚度大致为20密耳。
5. 根据权利要求1所述的双面电极垫组件,其中所述上导电凝胶层包括水凝胶、硅树脂或水胶体。
6. 根据权利要求1所述的双面电极垫组件,其中所述中间导电层的厚度为0.1至10密耳。
7. 根据权利要求1所述的双面电极垫组件,其中所述中间导电层的厚度大致为1密耳。
8. 根据权利要求1所述的双面电极垫组件,其中所述中间导电层的导电箔包括金属箔或石墨箔。
9. 根据权利要求1所述的双面电极垫组件,其中所述中间导电层的凝胶层中的悬浮导电颗粒包括金属颗粒、石墨颗粒或石墨烯颗粒。
10. 根据权利要求1所述的双面电极垫组件,其中所述下导电凝胶层的厚度为20至120密耳。
11. 根据权利要求1所述的双面电极垫组件,其中所述下导电凝胶层的厚度为40密耳。
12. 根据权利要求1所述的双面电极垫组件,其中所述下导电凝胶层包括水凝胶、硅树脂或水胶体。
13. 根据权利要求1所述的双面电极垫组件,包括设置在所述上导电凝胶层上的可移除的上保护衬里,其中所述上保护衬里与所述上导电凝胶层、中间导电层和下部导电凝胶层相比表面积更大。
14. 根据权利要求1所述的双面电极垫组件,包括设置在所述下导电凝胶层上的可移除的下保护衬里,其中所述下保护衬里与所述上导电凝胶层、中间导电层和下部导电凝胶层相比表面积更大。
15. 根据权利要求1所述的双面电极垫组件,其中所述上导电凝胶层与所述中间导电层相比表面积更小,从而允许所述中间导电层的周边边缘设置在所述上导电凝胶层的边缘之外。
16. 根据权利要求15所述的双面电极垫组件,其中所述下导电凝胶层与所述中间导电层相比表面积更大,从而允许所述下导电凝胶层的周边边缘设置在所述中间导电层的周边边缘之外。
17. 根据权利要求1所述的双面电极垫组件,其中所述上导电凝胶层和所述中间导电层通常具有相同尺寸的表面积,并且其中所述下导电凝胶层与所述上导电凝胶层和中间导电

层相比表面积更大,从而允许所述下导电凝胶层的周边边缘设置在所述上导电凝胶层和所述中间导电层的边缘之外。

18.根据权利要求1所述的双面电极垫组件,其中所述中间导电层与所述上导电凝胶层和所述下导电凝胶层相比表面积更小,从而允许所述上导电凝胶层和所述下导电凝胶层的周边边缘设置在所述中间导电层的周边边。

19.根据权利要求1所述的双面电极垫组件,其中所述中间导电层包括标记。

20.根据权利要求19所述的双面电极垫组件,其中所述标记被压印到所述中间导电层中。

21.根据权利要求19所述的双面电极垫组件,其中所述标记被激光蚀刻到所述中间导电层上。

22.根据权利要求19所述的双面电极垫组件,其中所述标记印刷在所述中间导电层上。

23.根据权利要求1所述的双面电极垫组件,其中所述中间导电层包括设置在所述上导电凝胶层和所述下导电凝胶层之间的多个单独的中间导电层。

24.根据权利要求1所述的双面电极垫组件,包括形成在所述中间导电层中的至少一个切口。

25.根据权利要求1所述的双面电极垫组件,包括形成在所述上导电凝胶层或所述下导电凝胶层中的至少一个切口。

26.根据权利要求1所述的双面电极垫组件,包括在所述上导电凝胶层、所述中间导电层和所述下导电凝胶层中类似地形成的至少一个切口。

27.根据权利要求26所述的双面电极垫组件,其中所述切口包括圆形、正方形、矩形、三角形、卵形、椭圆形、四叶形、曲线三角形、梯形、菱形、风筝形、五边形、六边形、七边形、八边形、九边形、十边形、平行四边形或新月形。

28.根据权利要求1所述的双面电极垫组件,包括设置在所述中间导电层上的至少一个墨水图案,其中所述至少一个墨水图案与所述中间导电层相比包括更高的电阻率。

29.根据权利要求2所述的双面电极垫组件,其中所述导电箔或所述导电塑料膜包括至少两种具有不同电阻率的材料。

30.根据权利要求2所述的双面电极垫组件,其中所述凝胶层的悬浮导电颗粒包括至少两种具有不同电阻率的材料。

31.一种双面电极垫组件,配置为放置在患者皮肤上,所述双面电极垫组件包括:

上导电凝胶层,其中所述上导电凝胶层的厚度为5-50密耳,体积电阻率大于100欧姆-厘米;

中间导电层,其包括导电箔、导电塑料膜或具有悬浮导电颗粒的凝胶层,其中所述中间导电层的厚度为0.1至10密耳,表面电阻率小于10欧姆;

下导电凝胶层,其中所述下导电凝胶层的厚度为20-120密耳,体积电阻率大于100欧姆-厘米;

其中,所述上导电凝胶层和所述下导电凝胶层包括水凝胶、硅树脂或水胶体;

可移除的上保护衬里,其设置在所述上导电凝胶层上,其中所述上保护衬里与所述上导电凝胶层、所述中间导电层和所述下导电凝胶层相比表面积更大;以及

可移除的下保护衬里,其设置在所述下导电凝胶层上,其中所述下保护衬里与所述上

导电凝胶层、所述中间导电层和所述下导电凝胶层相比表面积更大。

32. 一种双面电极垫组件,配置为放置在患者皮肤上,所述双面电极垫组件包括:

上导电凝胶层,其中所述上导电凝胶层的厚度为5-50密耳,体积电阻率大于100欧姆-厘米;

中间导电层,其包括导电箔、导电塑料膜或具有悬浮导电颗粒的凝胶层,其中所述中间导电层为0.1至10密耳厚;

下导电凝胶层,其中所述下导电凝胶层的厚度为20-120密耳,体积电阻率大于100欧姆-厘米;

其中,所述上导电凝胶层和所述下导电凝胶层包括水凝胶、硅树脂或水胶体;

可移除的上保护衬里,其设置在所述上导电凝胶层上,其中所述上保护衬里与所述上导电凝胶层、所述中间导电层和所述下导电凝胶层相比表面积更大;以及

可移除的下保护衬里,其设置在所述下导电凝胶层上,其中所述下保护衬里与所述上导电凝胶层、所述中间导电层和所述下导电凝胶层相比表面积更大,并且

其中,所述中间导电层与所述上导电凝胶层和所述下导电凝胶层相比表面积更小,从而允许所述上导电凝胶层和所述下导电凝胶层的周边边缘设置在所述中间导电层的周边边缘之外。

33. 一种双面电极垫组件,配置为放置在患者皮肤上,所述双面电极垫组件包括:

上导电凝胶层;

中间导电层,其包括导电箔、导电塑料膜或具有悬浮导电颗粒的凝胶层;

下导电凝胶层;

其中所述中间导电层设置在所述上导电凝胶层和所述下导电凝胶层之间。

## 双面电极垫

[0001] 相关申请的交叉引用

[0002] 该PCT国际申请要求2017年1月25日提交的美国专利申请第15/415,621号的优先权,其要求2016年1月26日提交的美国临时申请第62/287,393号的优先权,其全部内容通过引用并入本文中。

### 发明领域

[0003] 本发明一般地涉及电极。更特别地,本发明涉及双面电极垫。

### 背景技术

[0004] 在现有技术中,在2002年8月20日授权的美国专利6,438,428中教导了电刺激电极,其内容在此通过引用完全并入本文中。现在参考图4,其示出了电垫40的分解图。每个导电垫40包括覆盖导电凝胶粘合剂层42、电流控制介质50和基础导电凝胶粘合剂层56。如图4所示,所有这些层都在相同的周边位置处结束。如'428专利中所教导的,这些电极40通常与有助于将电极40保持就位的服装或支架一起使用。当不使用电极40时,可以将它们存储起来供以后使用。该设计的问题在于,层50的边缘可能在使用期间与使用者/患者的皮肤接触。这可能会导致局部加热或不希望的热点。

[0005] 然后,在现有技术中,在2003年5月27日授权的美国专利6,571,115中教导了促进使用医用电极的压缩衣服,其内容通过引用完全并入本文中。现在参考图14,它示出了电流控制介质如何不再出现边缘,而是具有设置在周边的边界部分。

[0006] 这因此消除了局部加热和不期望的热点,这是因为电流控制介质层具有低导电率的周边边界区域。然而,由于添加了导电图案的印刷,这导致昂贵的电极结构。

[0007] 因此,需要一种克服现有技术缺点的改进电极。本发明满足了这些需求并提供了其它相关的优点。

### 发明内容

[0008] 本发明的示例性实施例是一种双面电极垫组件,其被配置为放置在患者的皮肤上,该双面电极垫组件包括:上导电凝胶层;包括金属箔层、石墨层或任何高导电的电流分布介质的中间导电层;和下导电凝胶(gel)层;其中中间导电层设置在上导电凝胶层和下导电凝胶层之间。

[0009] 在其它示例性实施例中,上导电凝胶层可以是5至50密耳(mil)厚,或者上导电凝胶层通常可以是大约20密耳厚。上导电凝胶层可包括水凝胶(hydrogel)、硅树脂(silicone)或水胶体(hydrocolloid)。

[0010] 在其它示例性实施例中,中间导电层可以是0.1至10密耳厚,或者中间导电层通常可以是大约1密耳厚。中间高导电箔层可包括铝、锡、石墨、石墨烯或任何高导电材料。

[0011] 在其它示例性实施例中,下导电凝胶层可以是20至120密耳厚,或者下导电凝胶层通常可以是40密耳厚。下导电凝胶层可包括水凝胶,硅树脂或水胶体。

[0012] 在其它示例性实施例中,可移除的上保护衬里可以设置在上导电凝胶层上,其中上保护衬里与上导电凝胶层、中间导电层和下导电凝胶层相比表面积更大。此外,可移除的下保护衬里可设置在下导电凝胶层上,其中下保护衬里与上导电凝胶层、中间导电层和下导电凝胶层相比表面积更大。

[0013] 在其它示例性实施例中,上导电凝胶层与中间导电层相比表面积可以更小,从而允许中间导电层的周边边缘设置在上导电凝胶层的边缘之外。下导电凝胶层与中间导电层相比表面积可以更大,从而允许下导电凝胶层的周边边缘设置在中间导电层的周边边缘之外。

[0014] 在其它示例性实施例中,上导电凝胶层和中间导电层通常可具有相同尺寸的表面区域,并且其中下导电凝胶层与上导电凝胶层和中间导电层相比表面积更大,从而允许下导电凝胶层的周边边缘设置在上导电凝胶层和中间导电层的边缘之外。

[0015] 在其它示例性实施例中,中间导电层与上导电凝胶层和下导电凝胶层相比表面积可以更小,从而允许上导电凝胶层和下导电凝胶层的周边边缘设置在中间导电层周边边缘之外。

[0016] 在其它示例性实施例中,中间导电层可包括标记。该标记可以压印到中间导电层中。可以将标记激光蚀刻到中间导电层上。该标记可以印刷到中间导电层上。

[0017] 在其它示例性实施例中,中间导电层可以包括设置在上导电凝胶层和下导电凝胶层之间的多个单独的中间导电层。

[0018] 在其它示例性实施例中,可以在中间导电层中形成至少一个切口。至少一个切口可以形成在上导电凝胶层或下导电凝胶层中。该至少一个切口可以类似地形成在上导电凝胶层、中间导电层和下导电凝胶层中。该切口的形状可包括圆形、正方形、矩形、三角形、卵形、椭圆形、四叶形、曲线三角形、梯形、菱形、风筝形、五边形、六边形、七边形、八边形、九边形、十边形、平行四边形或新月形。

[0019] 在其它示例性实施例中,电极可包括设置在中间导电层上的至少一个墨水图案,其中与中间导电层相比,该至少一个墨水图案包括更高的电阻率。在另一个实施例中,导电箔或导电塑料膜可包括至少两种具有不同电阻率的材料。或者,凝胶层的悬浮导电颗粒可包含至少两种具有不同电阻率的材料。可以看出,这些都是本发明中的可用于控制电流分布的结构实施例。

## 附图说明

[0020] 附图绘示了本发明,在这样的附图中:

[0021] 图1是通过本发明的示例性电极的剖视图;

[0022] 图2是通过本发明的另一个示例性电极的剖视图;

[0023] 图3是通过本发明的又一个示例性电极的剖视图;

[0024] 图4是具有压纹标记的层C的透视图;

[0025] 图5是具有激光蚀刻或印刷标记的层C的两侧的透视图;

[0026] 图6是现在放在患者身上图3的示例性电极的剖视图;

[0027] 图7是放置在患者前臂上的本发明的示例性电极的透视图;

[0028] 图8类似于图7,现在示出了放置在患者前臂上的多个电极,其中探针选择性地激

活某些电极；

[0029] 图9是处于刺激和非刺激状态的本发明电极的透视图。

[0030] 图10是本发明另一实施例的俯视图，示出了电极可包括多个部分并且还包括切口；以及

[0031] 图11是本发明的又一个实施例的俯视图，示出了电极可包括多个部分和不同尺寸和形状的切口。

### 具体实施方式

[0032] 图1是本发明的双面电极垫组件10的新实施例的剖视图。图1未按比例绘制，而是为了简单起见而绘制得更厚，以表达本发明的概念和教导。

[0033] 层A是在使用电极本身之前去除的保护性衬里。层A的表面积（即电极的直径或宽度）明显过大，使得它延伸到其它有源层B、C和D之外。这使得，当使用电极本身时，可以容易地去除层A。层A通常是2-3密耳厚的中密度聚乙烯的半透明蓝色硅树脂衬里。

[0034] 层E也是在使用电极本身之前去除的保护性衬里。层E可以由聚酯（Mylar）或本领域技术人员已知的其它合适的衬里材料制成。层E也是过大尺寸的，通常2-5密耳厚，使得当不使用电极10时，易于将硅树脂涂覆的膜放置在皮肤侧凝胶上。Mylar通常是以彩色或印刷而具有说明，且以这样的方式，即，如果它落在地板上将是可见的，从而防止落在光滑的硅胶上。

[0035] 层A和E在运输和储存期间保护电极10。层A和E还防止灰尘、颗粒和其它污染物弄脏电极10。此外，层A和E防止粘性凝胶B和D粘附到其它物体上。层A和E有助于防止电极10干燥，因为层B和D通常是导电水凝胶层，如果保持未被覆盖则可能变干燥。因此，即使在使用电极10本身之后，也可以重复使用层A和E，以进一步保护电极10直到电极下次使用。

[0036] 层B和D是导电凝胶。在该实施例中，层B的厚度约为20密耳，但可以制成5-50密耳厚的范围。层D的厚度约为40密耳厚，但可以制成20-120密耳厚的范围。用于层B和D的导电凝胶可以由任何导电粘合剂制成，例如，水凝胶、硅树脂、水胶体等。参见现有技术：如2008年3月18日授权的美国专利第7,346,380号“医学电极”中所教导的，该专利全文通过引用并入本文中。

[0037] 在现有技术专利6,571,115中，电流控制介质50是印刷碳膜，其制造昂贵。在本发明中，层C是导电金属箔、石墨层或任何其它高导电介质。层C的厚度可以为约1密耳，或者在0.1-10密耳的范围内。在层C中使用1密耳的铝箔，显著降低了整个电极组件10的成本。

[0038] 如图1所示，与层C相比，层B的表面积（即，其在电极上的直径或宽度/长度）更小，这可以在过大之一（oversize one）（ $O_1$ ）尺寸中看到。然后，与层D相比，层C的表面积更小，这可以在过大之二（oversize two）（ $O_2$ ）尺寸中看到。而且，与层B、C和D相比，层A和层E尺寸过大，这可以在过大之三（oversize three）（ $O_3$ ）尺寸中看到。在该实施例中，有源层的不同表面面积防止和/或减少边缘燃烧或不期望的局部加热的可能性。B层可以具有小于C层的任何尺寸（ $O_1$ ），而D层优选地沿边缘比C层大1/4”，但是可以在超大1/8”至5/8”的范围内（ $O_2$ ）。在一个实施例中，A和E层可以比D层大1/4”或更大（ $O_3$ ），但可以是等于或大于1/8”的最小过大尺寸。

[0039] 如图1所示，与层C和D相比，层B的表面积更小。然而，在其它实施例中，层B可以与

层C的尺寸相同,而其中层D与层B和C相比尺寸过大(0<sub>4</sub>)。该实施例在图2中最佳示出。

[0040] 或者,层B可以与层D具有相同的尺寸(表面积),而现在层B和D与层C相比尺寸过大(0<sub>5</sub>)。该实施例在图3中最佳示出。在所有这些实施例中,减少和/或消除了边缘燃烧或不希望的局部加热的可能性。

[0041] 图3还教导了使用电极10的安全性的显著优点。在一些情况下,电极可能被使用者/患者倒置放置。这可能是在使用过程中由于无意的错误而发生的,因为人们可能会疲惫不堪或者没有密切关注。图3示出了,层B和D与层C相比都是过大的。这种独特的结构允许图3中的电极倒置,并且仍然不会产生热点或不希望的局部加热。

[0042] 如在图1-3中可以理解和看到的那样,不再需要使用具有未印刷边界的印刷碳膜。现在,可以替代地使用导电箔,可以使用这样的金属箔、石墨箔或任何其它高导电性更便宜的介质。例如,导电塑料薄膜层可用于本发明。此外,可以使用水凝胶层,其中水凝胶层包含悬浮金属、石墨、石墨烯或其它高导电颗粒。导电颗粒不仅可以悬浮在水凝胶中,还可以悬浮在硅树脂或水胶体凝胶层中。

[0043] 现在参考图4,在另一个实施例中,可以用可能对用户或制造商有用的各种标记12来压印层C。例如,层C可以压印有徽标或商标12以帮助识别电极的制造商。或者,层C可以压印有帮助用户使用电极10的各种指示。在另一个实施例中,压印层C可以在层C具有约1密耳的厚度时完成,但是也可以压印其它厚度。可以看到这样的压印结构,因为通常层B和/或D至少部分地光学透明,使得用户可以看到在层C上压印的是什么。

[0044] 在压印步骤期间,也可以同时切割14层C。例如,在制造中,压印步骤12和切口步骤14可以一个接一个地,或者同时完成,以加速制造过程。

[0045] 现在参考图5,在另一个实施例中,可以将各种标记16激光刻蚀到层C中。激光刻蚀可以产生非常准确和详细的信息16。再次,可以将各种徽标或指示直接激光刻蚀到C层。

[0046] 在另一个实施例中,可以将各种标记18印刷到层C上。印刷也可以产生非常准确和详细的信息。

[0047] 作为本发明的一个示例,当层C从0.70美元/LnFt(线性英尺)的碳膜变为现在的0.02美元/LnFt的铝箔时,实现了成本的显著降低(因子35)。材料的这种变化与图1-3中教导的新的超大尺寸配置相结合,是对现有技术的重大改进。

[0048] 现在参考图6和图7,同样重要的是要理解,本发明的实施例可以与现有技术中的服装或支架一起使用,但也可以在没有这种服装或支架的情况下使用。例如,本发明的电极10可以与任何电连接装置20一起使用,该电连接装置20将电信号传导到层B,然后层B通过层C和D并最终传导到用户/患者的皮肤22。因此,不再需要使用服装或支架来实践本文所教导的本发明的实施例。

[0049] 图7以放置在使用者/患者的前臂24上的更逼真的透视图示出了电极10。

[0050] 现在参照图8,可以通过物理治疗师将多个双面电极10放置在皮肤上,如在前臂上部位置所见,其中B和D层与C层相比尺寸过大。还如图8所示,在手腕附近,基本上大的B和D层在其间包含多个较小的C层。如图8中所示,参考图1-3,可以有多种方式将本发明配置成不同类型的电极。然后,本领域技术人员应理解,本文所教导的任何电极实施例(图1-3)可用于上述方法中。

[0051] 通常,对于肌肉刺激,两个电极位置用于在刺激时引起这些电极位置之间的肌肉

的适当肌肉收缩。例如,一个探针26可以激活上前臂上的电极,而第二探针26可以激活手腕附近的电极。因此,两个探针26然后可用于激活某些肌肉以进行刺激。通过将两个探针26从电极对移动到电极对,从业者通过比较可以快速且准确地确定实际治疗电极的最佳永久电极放置。这在概念上与1999年5月18日授权的美国专利5,904,712中的图6和2000年3月14日授权的美国专利6,038,485中的图6类似,其内容通过引用完全并入本文中。

[0052] 为了更好地帮助读者理解电极如何在实践中工作,可以参考2013年6月25日授权的美国专利8,473,072中的图7和2014年10月28日授权的美国专利8,874,231,其内容通过引用完全并入本文中。这在本发明中也如图9所示。图9是连接到患者前臂24的电极10的透视图。在上部视图中,电极处于关闭状态并且不传输任何电信号。患者的手显示为闭合状态。下部视图显示电极处于激活状态,因此患者的手是打开的。如本领域技术人员可以理解的,电极10可以配置成沿着患者的任何其它身体部位放置。

[0053] 本发明还可以设计成结合可以在层B、C或D中的任何层中形成的各种切口或空隙。例如,图10示出了类似于美国专利公开2007/0238944中的图9的视图,其内容全部并入本文。图10是本发明的电极10的另一个实施例的俯视图,其中切口28形成在四个单独控制的电极之间。本发明的图11也类似于'944专利公开中的图8。图11示出了可以使用各种切口28。例如,大的矩形切口28可以分开两个电极部分。或者,多个不同形状的切口28可包括圆形、六边形、三角形、正方形、半圆形等。如本领域技术人员可以理解的,可以使用现有技术电极的许多方式使用本发明,但是现在以更便宜的制造成本使用。

[0054] 这里应理解,任何层B、C或D中的切口28或空隙28可用于控制任何这种层的导电率/电阻率。例如,为了更好地控制层C中的电流分布,可以使用在层C中形成的切口。或者,层C可以用丝网印刷或者用各种不导电的墨水28或具有比层C更高电阻率的墨28涂覆。切口28是控制电流分布的机械机制,而使用导电性较差的墨28更多是用于控制电流分布的电气机制。

[0055] 为了实现通过层C的电流分布的更多控制,可以使用具有不同电阻率的两种(或更多种)材料。例如,层C可以包括选择性地切割并邻近铝箔或锡箔放置的石墨箔。与铝箔或锡箔相比,石墨的电阻更大。同样,当C层是具有悬浮导电颗粒的凝胶层时,可以使用两种不同的导电颗粒材料。例如,石墨颗粒可以在一个位置使用,而铝或锡颗粒可以在别处使用。以这种方式,可以更好地控制通过层C的电流分布,同时仍然导致现有技术电极的更便宜和更简单的替代。

[0056] 还应理解,本发明的电极10可以制成各种形状,包括但不限于圆形、正方形、矩形、三角形、卵形、椭圆形、四叶形、曲线三角形、梯形、菱形、风筝、五边形、六边形、七边形、八边形、非九边形、十边形、平行四边形、新月形和任何其它可能的形状,因为本公开不限于本文所示的形状。

[0057] 还应理解,在本发明中,层C是高导电层,而层B和D是导电的。换言之,层C是与层B或D相比具有更高导电率的层。通常,凝胶和导电箔不同地测量电阻率,箔测量的是表面电阻率(surface resistance)而凝胶测量的是体积电阻率(volume resistivity)。通常,B层和D层的体积电阻率大于100欧姆-厘米,C层的表面电阻率小于10欧姆。可以看出,与层B和D相比,层C是高导电层。

[0058] 作为本发明的一个示例,以下测量适用:

- [0059] 层B,USB35凝胶,厚度35密耳,体积电阻率1233欧姆-厘米,表面电阻率6500;
- [0060] 层D,USS35凝胶,厚度34密耳,体积电阻率1450欧姆-厘米,表面电阻率8600;
- [0061] 层C,石墨,厚度5密耳,表面电阻率4欧姆;
- [0062] 层C,铝,厚度5密耳,表面电阻率0.22欧姆;
- [0063] 层C,锡,厚度2.5密耳,表面电阻率0.08欧姆。
- [0064] 有关进一步的信息,参考2010年8月3日授权的美国专利7,769,473,其内容通过引用完全并入本文中。
- [0065] 有关进一步的信息,参考2000年3月14日授权的美国专利6,038,464,其内容通过引用完全并入本文中。
- [0066] 如本文所用,密耳(mi1)是千分之一英寸,其为0.001英寸。
- [0067] 尽管为了说明的目的已经详细描述了若干实施例,但是在不脱离本发明的范围和精力的情况下,可以对每个实施例进行各种修改。因此,除了所附权利要求之外,本发明不受限制。



图1



图2

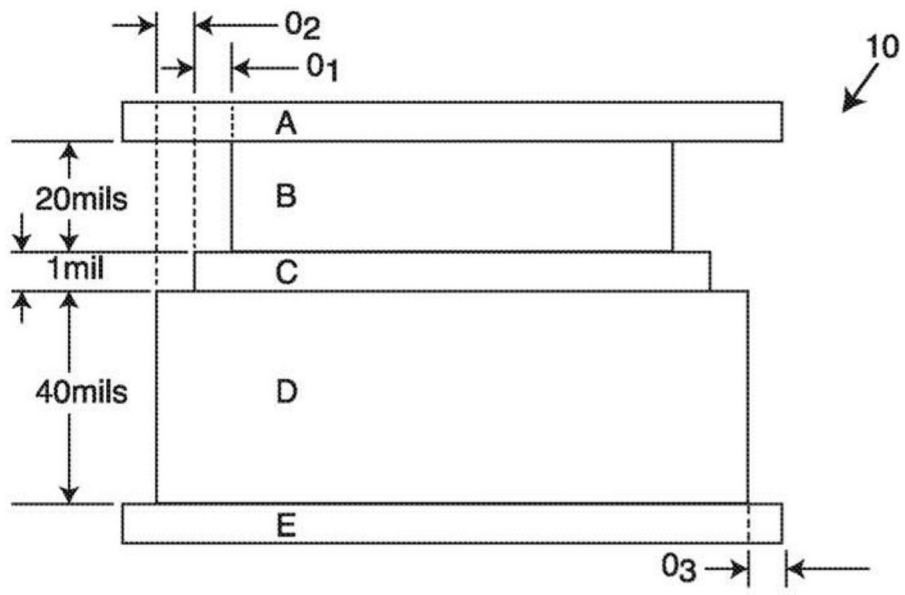

图3

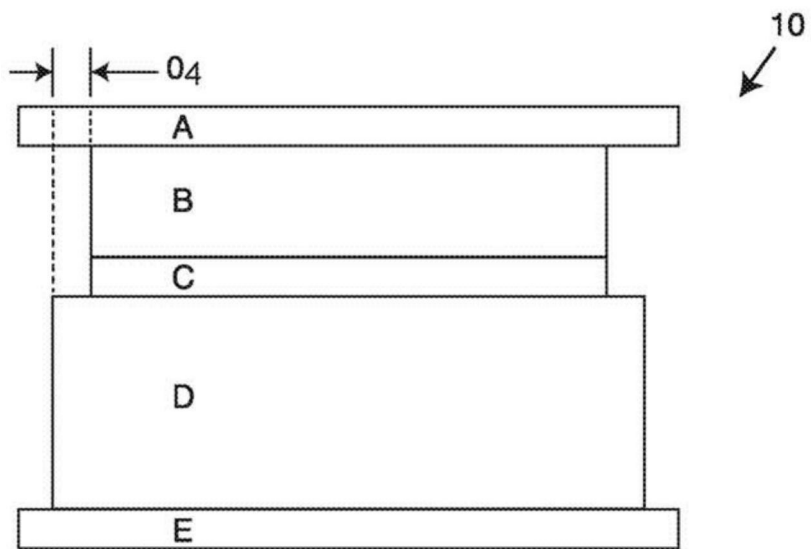

图4

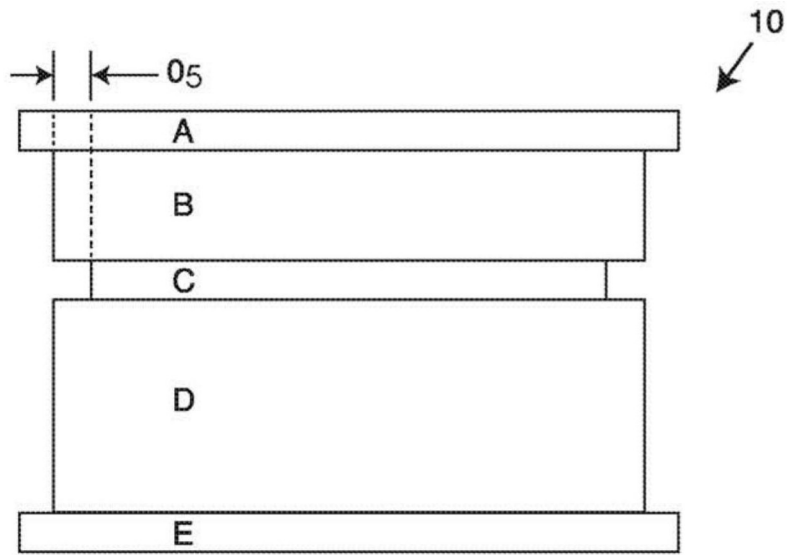

图5

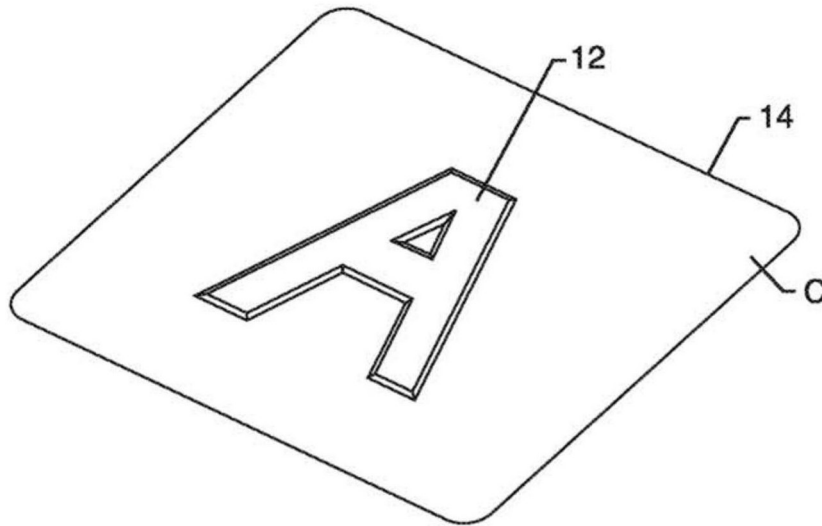

图6

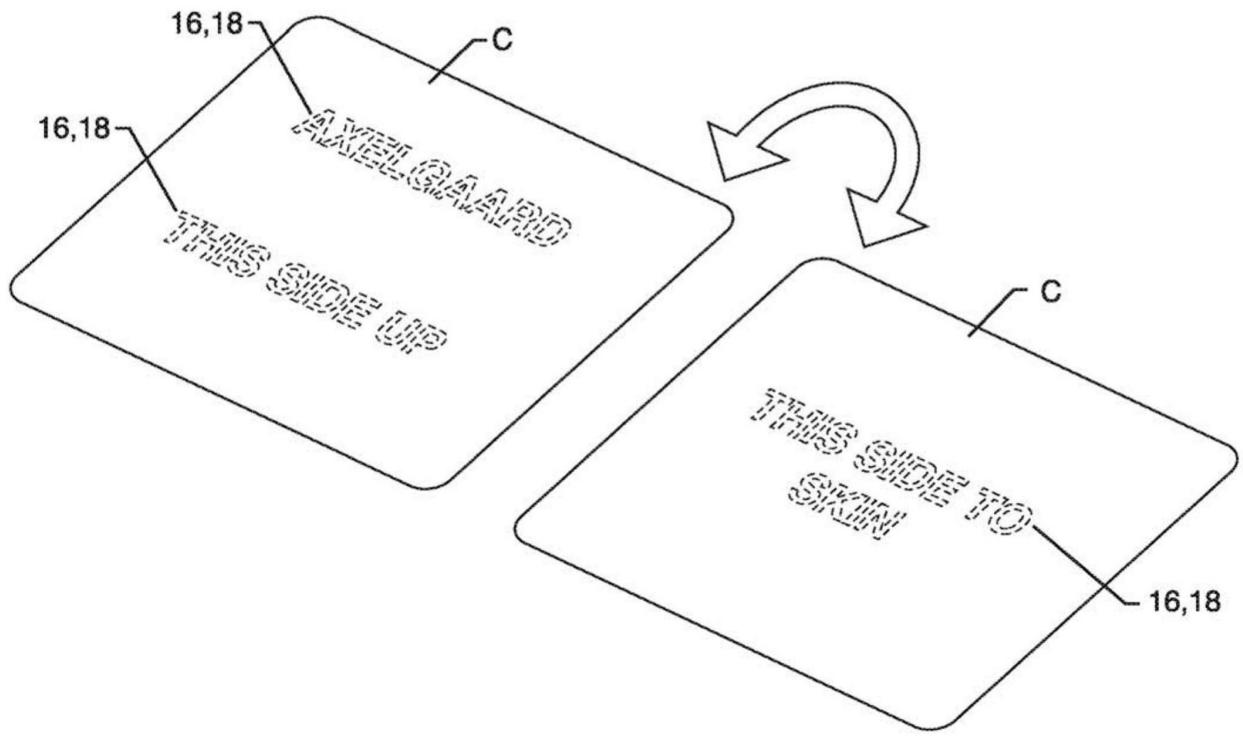

图7

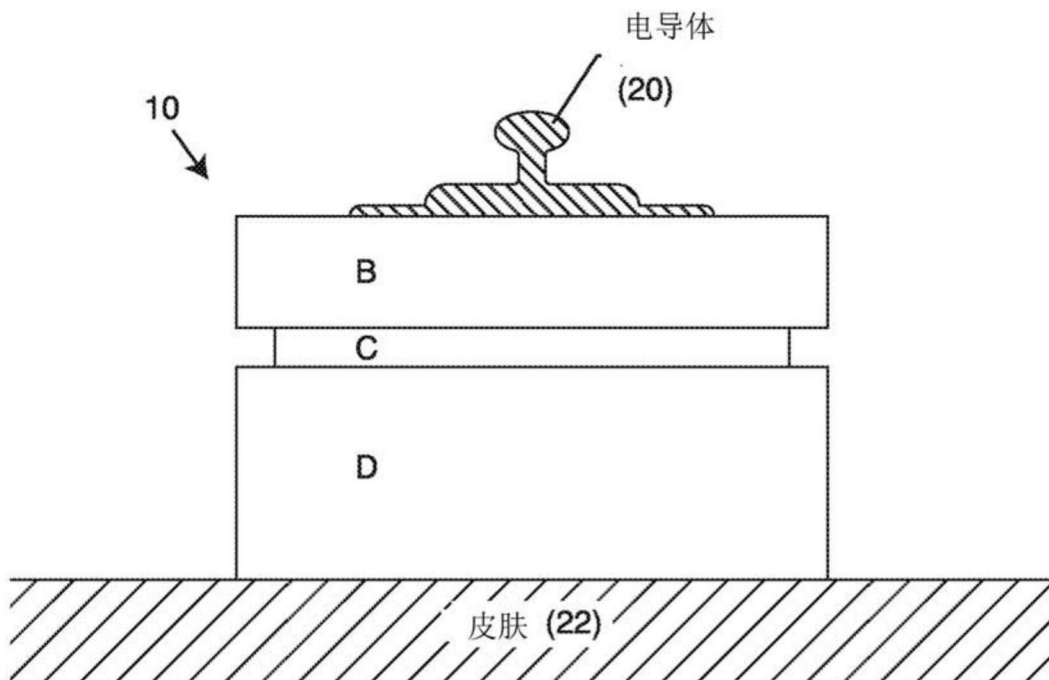

图8

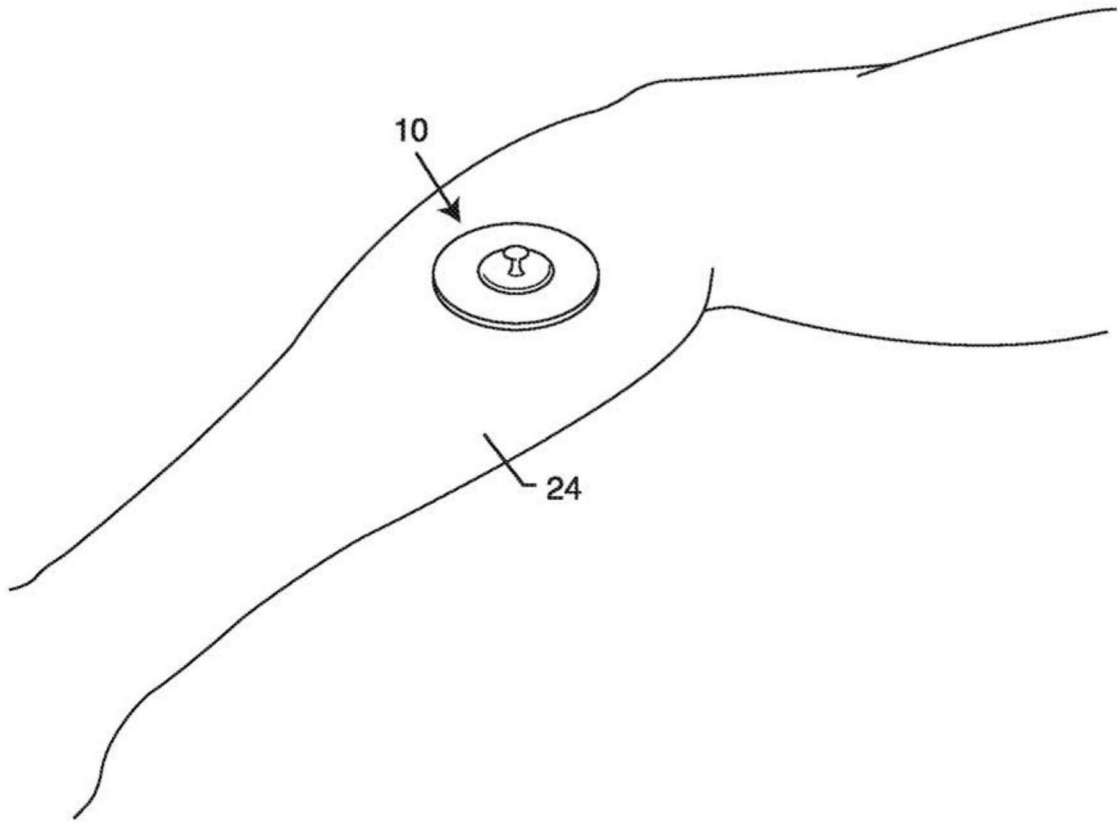

图9

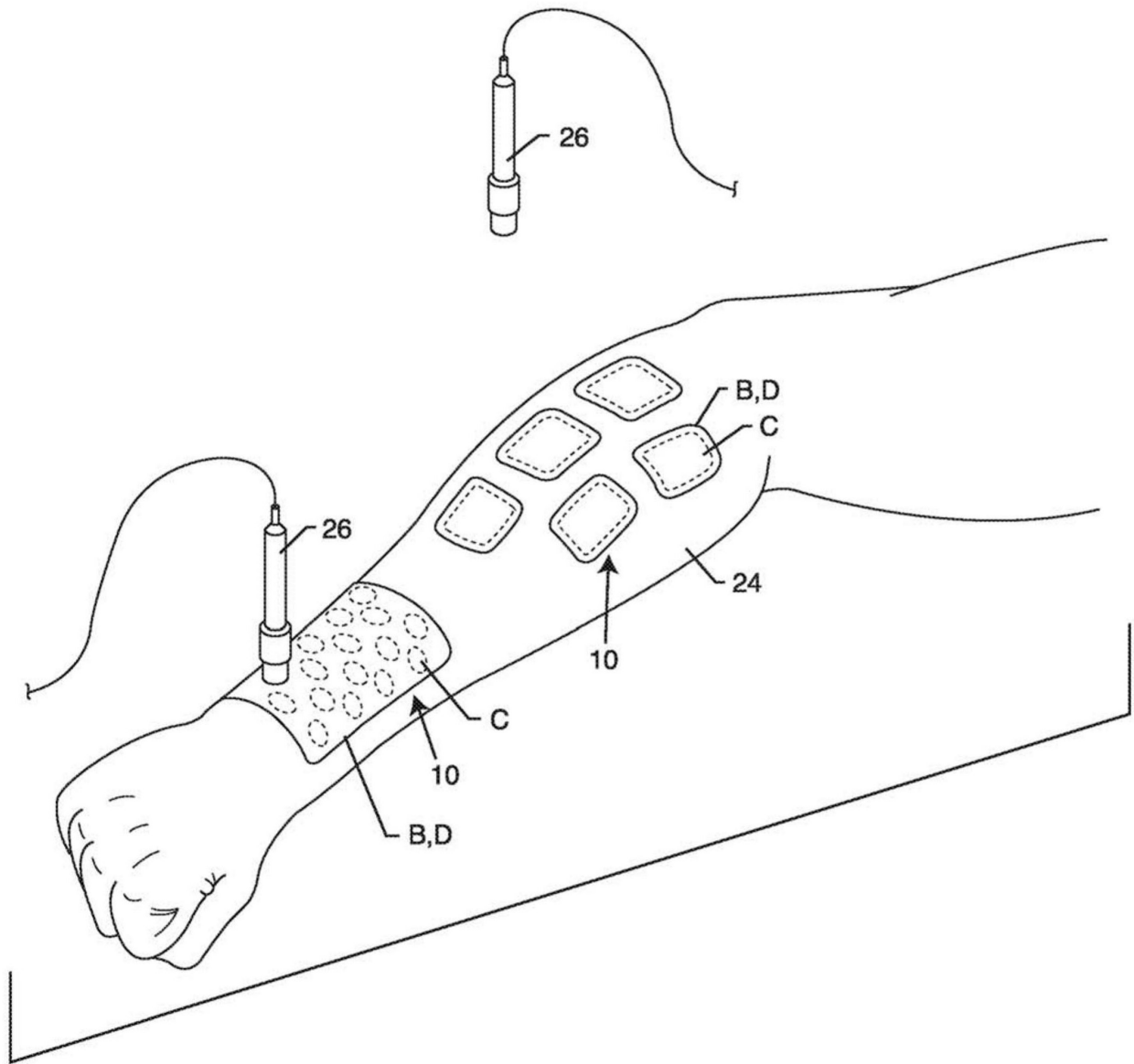

图10

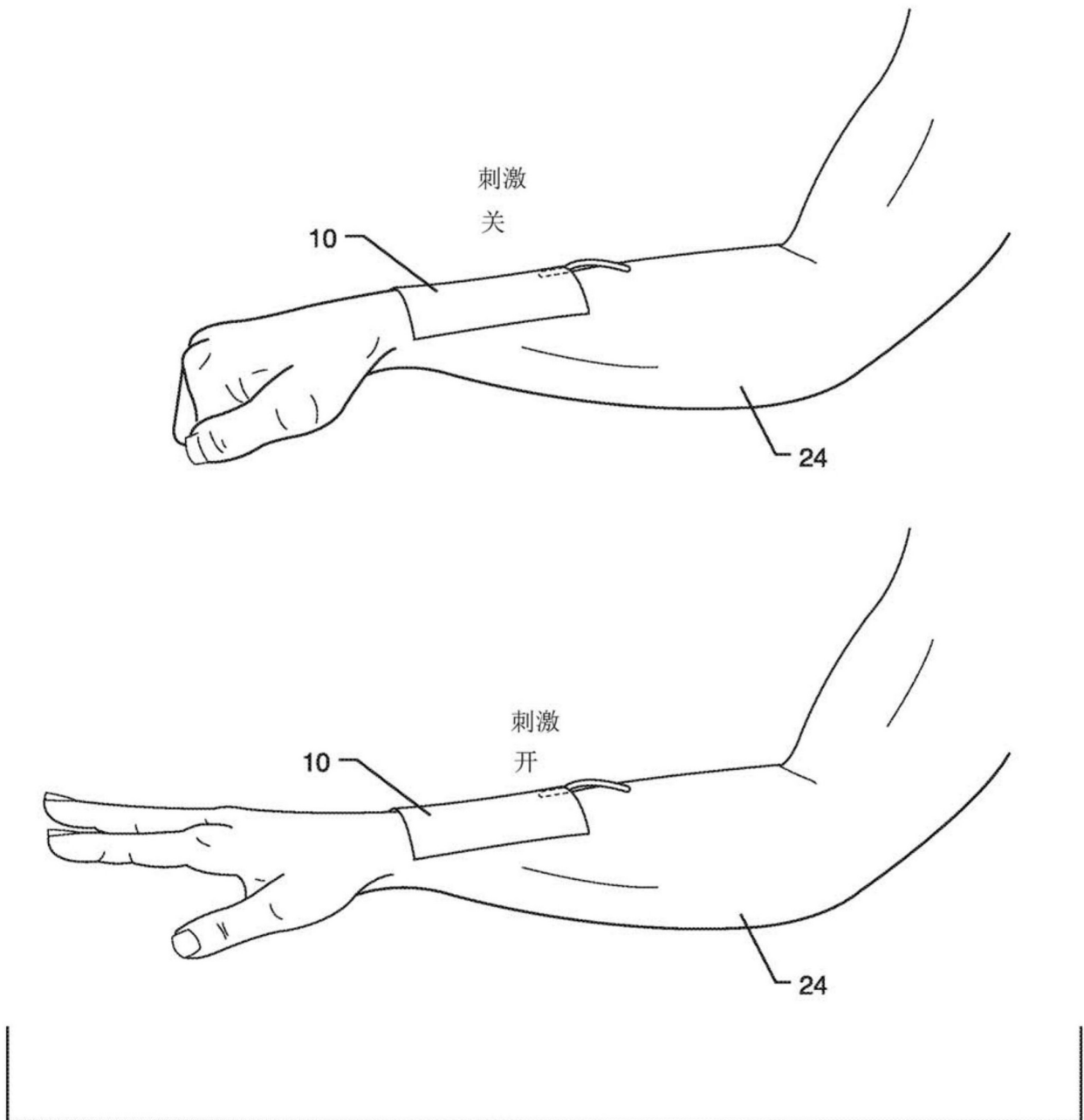
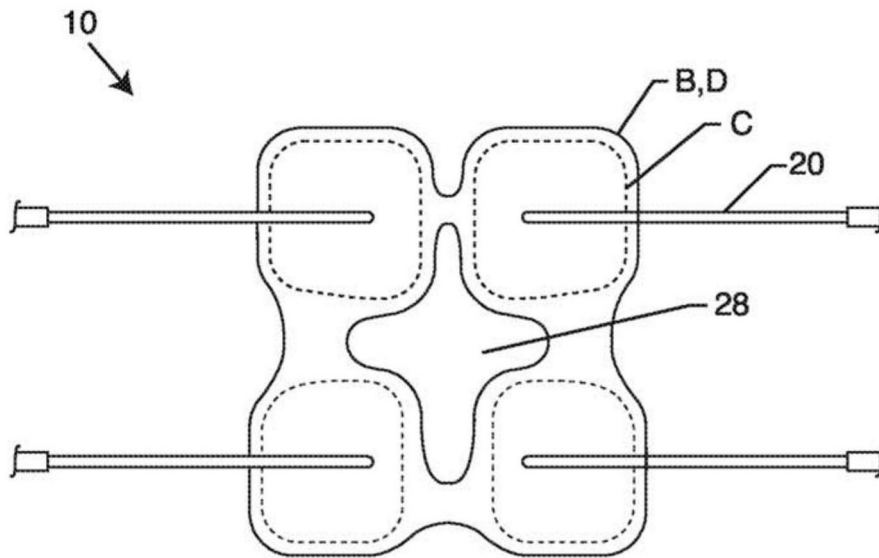
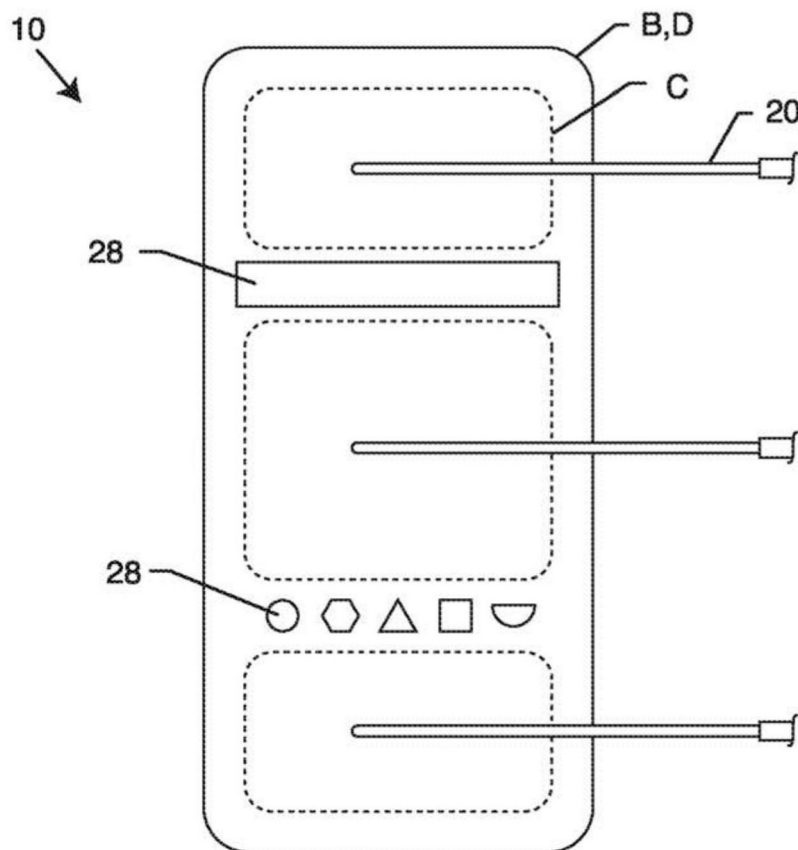

图11