

(19) World Intellectual Property Organization
International Bureau



(43) International Publication Date
28 March 2002 (28.03.2002)

PCT

(10) International Publication Number
WO 02/25694 A2

- (51) International Patent Classification⁷: **H01J 37/32**
- (21) International Application Number: PCT/GB01/03797
- (22) International Filing Date: 23 August 2001 (23.08.2001)
- (25) Filing Language: English
- (26) Publication Language: English
- (30) Priority Data:
09/664,146 18 September 2000 (18.09.2000) US
- (71) Applicant: **AXCELIS TECHNOLOGIES, INC.**
[US/US]; 55 Cherry Hill Drive, Beverly, MA 01915 (US).
- (71) Applicant (for CA only): **EATON LIMITED** [GB/GB];
P.O. Box 22, Norfolk Street, Worsley Road North, Worsley,
Manchester M28 3ET (GB).
- (72) Inventors: **BERNSTEIN, James, David**; Apt. #3308,
12500 Merit Drive, Dallas, TX 75251 (US). **KELLER-
MAN, Peter, Lawrence**; 94 John Wise Avenue, Essex, MA
01929 (US).
- (74) Agents: **BURKE, Steven, D.** et al.; R.G.C. Jenkins & Co.,
26 Caxton Street, London SW1H 0RJ (GB).
- (81) Designated States (national): AE, AG, AL, AM, AT, AU,
AZ, BA, BB, BG, BR, BY, BZ, CA, CH, CN, CO, CR, CU,
CZ, DE, DK, DM, DZ, EE, ES, FI, GB, GD, GE, GH, GM,
HR, HU, ID, IL, IN, IS, JP, KE, KG, KP, KR, KZ, LC, LK,
LR, LS, LT, LU, LV, MA, MD, MG, MK, MN, MW, MX,
MZ, NO, NZ, PL, PT, RO, RU, SD, SE, SG, SI, SK, SL,
TJ, TM, TR, TT, TZ, UA, UG, UZ, VN, YU, ZA, ZW.
- (84) Designated States (regional): ARIPO patent (GH, GM,
KE, LS, MW, MZ, SD, SL, SZ, TZ, UG, ZW), Eurasian
patent (AM, AZ, BY, KG, KZ, MD, RU, TJ, TM), European
patent (AT, BE, CH, CY, DE, DK, ES, FI, FR, GB, GR, IE,
IT, LU, MC, NL, PT, SE, TR), OAPI patent (BF, BJ, CF,

[Continued on next page]

(54) Title: SYSTEM AND METHOD FOR CONTROLLING SPUTTERING AND DEPOSITION EFFECTS IN A PLASMA IMMERSION IMPLANTATION DEVICE

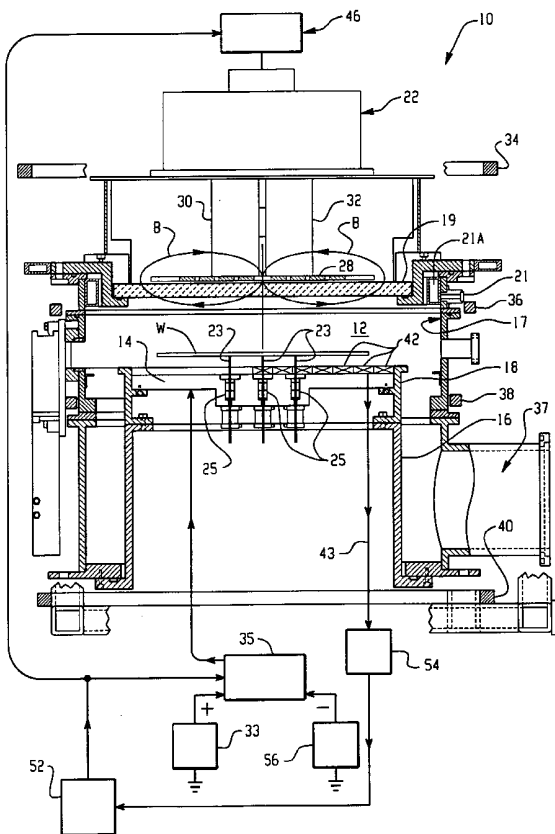

(57) Abstract: A plasma immersion ion implantation system (10) is provided for controlling the effects of sputtering and deposition during operation thereof. The system includes a chamber (12) for implanting wafers (W) positioned on a platen (14) therein with ions present in a plasma generated therein; a first power supply (33) for supplying a pulsed high voltage signal to the platen (14); a second power supply (46) for generating power necessary for igniting the plasma; a platen bias supply (56) for applying a bias voltage to the platen intermediate successive high voltage implant pulses; and a master implant controller (52). The master implant controller (52) simultaneously outputs a first control signal (72) to the second power supply (46) to ignite the plasma, and a second control signal (74) to a modulator (35) for applying a first of a series of high voltage implant pulses to the platen (14), so as to minimize the time the wafer (W) spends in the plasma prior to the first implantation pulse. The master implant controller further outputs a third control signal (76) for determining periods of time during which the successive high voltage implant pulses are applied to the platen. In addition, alternatively, (i) the master implant controller (52) further outputs a fourth control signal (78) for determining and varying periods of time intermediate times during which the successive high voltage implant pulses are applied to the platen, in response to a dose/current feedback signal, or (ii) the system (10) further includes a charge controller (54B) for outputting a bias control signal (84) for controlling the magnitude of the bias voltage applied to the platen (14) intermediate successive high voltage implant pulses.

WO 02/25694 A2



CG, CI, CM, GA, GN, GQ, GW, ML, MR, NE, SN, TD, TG).

For two-letter codes and other abbreviations, refer to the "Guidance Notes on Codes and Abbreviations" appearing at the beginning of each regular issue of the PCT Gazette.

Published:

— *without international search report and to be republished upon receipt of that report*

SYSTEM AND METHOD FOR CONTROLLING SPUTTERING AND DEPOSITION EFFECTS IN A PLASMA IMMERSION IMPLANTATION DEVICE

Related Application

The following U.S. patent application is incorporated by reference herein as if it had been fully set forth: Application Serial Number: 09/619,839, filed on July 20, 2000, entitled Integrated Power Oscillator RF Source for Plasma
5 Immersion Ion Implantation System.

Field of the Invention

The present invention relates generally to the field of plasma immersion ion implantation systems, and more specifically to a mechanism for
10 controlling the effects of both sputtering and deposition in such systems.

Background of the Invention

Plasma immersion ion implantation (PI-cubed or PI³) is an emerging technology wherein a substrate such as a wafer on a platen is immersed within an ionized plasma in a chamber. As such, the chamber functions as both the
15 processing chamber and the plasma source. Typically, a plasma is generated by ionizing a gas containing a desired species of dopant (e.g., boron (B), Arsenic (As) or phosphorous (P)). Positive ions within the plasma are attracted to (and implanted into) the wafer by periodically establishing a voltage differential between the walls of the chamber and the platen. A sufficient voltage differential (bias) periodically
20 applied to the platen will result in a pulsed ion implantation into the surface of the wafer.

A desired result of such systems is that the processed wafer possess uniform implant characteristics, in terms of both dose concentration and depth, across the surface thereof. Dosimetry devices are typically incorporated into plasma
25 immersion ion implantation systems to control the dose of ions implanted into the wafer. In addition, such systems can be used to deduce the ion energy distribution.

Generally, implantation occurs only while the platen is periodically

biased. Intermediate to such bias pulses, the wafer continues to reside within the plasma, which remains active during these times between implant pulses. As a result, deposition of the plasma constituents may occur on the surface of the wafer. Typically, dopant is deposited onto the surface of the wafer, and subsequently
5 "knocked into" the substrate by recoil implantation. Such deposition, sometimes referred to as chemadsorption, occurs only while the wafer is in contact with the plasma, and is due to both dopant ions and dopant neutrals dissociated by the plasma.

10 In addition, certain plasma immersion ion implantation processes, such as shallow junction formation, demand high dose concentrations at increasingly shallow depths. During the latter stages of such processes, previously implanted dopant may be sputtered away from the wafer by the ions presently being implanted.

15 The effects of sputtering and deposition may adversely affect the quality of the implant if these factors are not adequately addressed by the implantation system. For example, the dose control system may indicate that a certain desired dose has been achieved, when in actuality some of the dose may have been sputtered away. In addition, plasma constituents that are deposited on the surface of the wafer between implant pulses are likely to adversely affect the
20 ability of the system to control the depth of the implant.

It is an object of the present invention, therefore, to provide a system and method for controlling the effects of both sputtering and deposition in a plasma immersion ion implantation system.

Summary of the Invention

25 A plasma immersion ion implantation system is provided for controlling the effects of sputtering and deposition during operation thereof. The system includes a chamber for implanting wafers positioned on a platen therein with ions present in a plasma generated therein; a first power supply for supplying a pulsed high voltage signal to the platen; a second power supply for generating power
30 necessary for igniting the plasma; a platen bias supply for applying a bias voltage to the platen intermediate successive high voltage implant pulses; and a master

implant controller.

The master implant controller simultaneously outputs a first control signal to the second power supply to ignite the plasma, and a second control signal to a modulator for applying a first of a series of high voltage implant pulses to the platen, so as to minimize the time the wafer spends in the plasma prior to the first implantation pulse. The master implant controller further outputs a third control signal for determining periods of time during which the successive high voltage implant pulses are applied to the platen. In addition, alternatively, (i) the master implant controller further outputs a fourth control signal for determining and varying periods of time intermediate times during which the successive high voltage implant pulses are applied to the platen, in response to a dose/current feedback signal, or (ii) the system further includes a charge controller for outputting a bias control signal for controlling the magnitude of the bias voltage applied to the platen intermediate successive high voltage implant pulses.

15

Brief Description of the Drawings

Figure 1 is a cross sectional plan view of a plasma immersion ion implantation system into which is incorporated one embodiment of a deposition and sputtering control system constructed according to the principles of the present invention;

20

Figure 2 is a block diagram of the deposition and sputtering control system shown in Figure 1; and

Figure 3 is a block diagram of a second embodiment of the deposition and sputtering control system shown in Figure 1.

25

Detailed Description of a Preferred Embodiment

Referring now to the drawings, Figure 1 discloses a plasma immersion ion implantation system, generally designated 10. The system 10 includes an evacuated process chamber 12 that is defined by an electrically activatable wafer support platen 14 mounted on insulator 18, an electrically grounded chamber housing 16 having walls 17, and a quartz window 19. Plasma generated within the chamber 16 contains positively charged ions of a desired dopant species (e.g.,

30

arsenic (As), phosphorous (P) or boron (B)) that are implanted into a substrate, such as a semiconductor wafer W located therein, when a negatively charged voltage is applied to the platen 14. As shown in Figure 1, the wafer W is lifted off of the platen by pins 23 operated by pin assemblies 25. In this manner the wafer may be readily
5 installed into and removed from the plasma chamber via a loadlock assembly (not shown).

The plasma is generated in the process chamber 12 as follows. An ionizable dopant gas is introduced into the process chamber 12 by means of inlet 21 and perforated annular channel 21A that resides about the upper periphery of the
10 chamber. A radio frequency (RF) power oscillator 22 generates an RF signal (on the order of 13.5 megahertz (MHz)) which is coupled directly to a planar antenna 28, having inner and outer circular coils, via leads 30 and 32. The RF current generated within the antenna 28 creates a magnetic field that passes through the quartz window 19 into the process chamber 12.

The magnetic field lines are oriented in the direction shown by arrows
15 B, based on the direction of current through the antenna coils. The magnetic field penetrating the process chamber 12 through the quartz window 19 induces an electric field in the process chamber. This electric field accelerates electrons, which in turn ionize the dopant gas, which is introduced into the chamber through annular
20 channel 21A, to create a plasma. The plasma includes positively charged ions of the desired dopant that are capable of being implanted into wafer W when a suitable opposing voltage, provided by high voltage power supply 33, is periodically applied to platen 14 by modulator 35. Because the implantation process occurs in a vacuum, the process chamber 12 is evacuated by pumps (not shown) via pump
25 manifold 37.

Electromagnetic coils 34, 36, 38 and 40 are located outside of the process chamber 12. The purpose of the coils is to vary the magnetic field within the process chamber 12 to effectively vary the plasma diffusion rate, which varies the radial distribution of plasma density across the surface of the wafer, to insure a
30 uniform implant across the surface of the wafer. In the preferred embodiment, the electromagnetic coils include two larger main coils 34 and 40 disposed above and below, respectively, two smaller trim coils 36 and 38, which reside closer in proximity

to the process chamber 12.

In addition, the wafer platen 14 includes a dosimetry detector such as one or more Faraday current collectors or cups 42 located proximate the wafer W in chamber 12. The current collectors 42 are used to measure ion current density and thereby provide an indication of implant dose in the form of a dose feedback signal 43. The dose feedback signal 43 is thus used in a known manner to control the dose implanted into the wafer W. In a preferred embodiment of the present invention, as further explained herein, the dose feedback signal 43 is also used in the sputtering and deposition control system. The radio frequency (RF) power oscillator 22 is energized by DC oscillator power supply 46 (e.g., 3 kV DC). The power oscillator 22 incorporates the antenna 28 into its tank circuit, eliminating the need for a matching network that matches the impedance of the RF power oscillator 22 with that of the plasma load within the chamber. Use of such an integrated power oscillator enables automatic and immediate passive tracking of the antenna circuit resonant frequency, while insuring maximum power out of the antenna 28 by minimizing reflection of the RF signal back into the generator. In addition to eliminating the matching network, the integrated power oscillator 22 eliminates the need for associated controls, tuning capacitors, coupling cables and power feedback meters.

Further, the integrated power oscillator 22 provides the additional benefit of instantaneous plasma ignition at chamber pressures of about 0.5 millitorr (mTorr). Nearly instantaneous plasma ignition is possible since tuning of a matching network is not required. One such type of integrated power oscillator 22 is shown in Applicant's co-pending U.S. patent application Ser. No. 09/619,839 for Integrated Power Oscillator RF Source for Plasma Immersion Ion Implantation System, filed July 20, 2000, hereby incorporated by reference as if fully set forth herein.

The present invention provides means for controlling the implantation process in a manner that addresses the effects of both sputtering and deposition in a plasma immersion ion implantation system. As shown in both Figures 1 and 2, a first embodiment of a control system 50 includes the modulator 35, a master implant controller 52, a charge controller 54 that receives the dose feedback signal 43, and a platen bias supply 56.

The modulator 35 operates to control the timing during which a series of high voltage pulse are applied to the platen 14 by means of the high voltage power supply 33, and during which a low voltage bias pulse is applied to the platen by means of the platen bias supply 56, intermediate the high voltage pulses. The master implant controller 52 operates to control the modulator in terms of the timing of these pulses, and also to determine the duty cycle of the modulated high voltage pulse in order to control the time in between successive high voltage pulses. In this manner, the effects of sputtering and deposition are controlled in the implant process.

Specifically with reference to Figure 2, the modulator operation will first be explained in detail. Switch 58 is used to periodically apply or pulse a high voltage) to the platen 14 to enable implantation of positively charged ions in the plasma into a wafer W residing on the platen. The high voltage pulse has a magnitude in the range of -.5 kilovolts (kV) to -10 kV, and preferably on the order of -5 kV). The high voltage negative pulse is applied, generally for a time period of approximately 4 to 5 microseconds (4-5 μ sec) (though it can be as long as several hundred microseconds), through current limiting resistor 60 (20 Ω) and pulse shaping resistor 62 (10 Ω). Capacitor 64 installed between earth ground and the output of power supply 33 serves as a buffer to suppress power supply voltage spikes.

Switch 66 is connected between the platen 14 (via pulse shaping resistor 62) and platen bias supply 56 to provide approximately 0 to +20 volts to the platen 14 after switch 58 opens. Generally, switches 58 and 66 and resistors 60 and 62 are referred to herein as the platen voltage switching mechanism 67. Capacitor 68 installed between earth ground and the output of platen bias supply 56 functions to filter the bias supply output signal.

Switches 58 and 66 are preferably both high-voltage IGBT-type switches. The master implant controller 52 controls the operation of these switches in the platen voltage switching mechanism 67. Controller 52 may also be used to control the voltages output by high voltage power supply 33 and platen bias supply 56. As further explained below, the controller also (i) controls the duty cycle of the modulated high voltage pulse provided by power supply 33 (*i.e.*, optimizes the times

during which switch 58 is closed) based in part on a the output of charge controller 54, and (ii) coordinates the operation of platen voltage switching mechanism 67 with the oscillator power supply 46 such that the plasma in the chamber 12 is instantaneously ignited coincident with the closing of switch 58. The controller
5 includes necessary hardware and programmable software to permit such operation.

Switch 66 functions (opens and closes) in a carefully controlled sequential manner to both (i) insure a uniform implant energy distribution and (ii) minimize the charge accumulation of a substrate implanted by the system 10. Absent switch 66 and associated platen bias supply, a residual voltage remaining
10 after switch 58 opens (upon conclusion of an implant pulse) would continue to attract and implant positive ions into the wafer, although at gradually lesser energies (and hence depths) than are applied during the high voltage pulse. A residual voltage having a long fall time causes an energy spread in the ions that are implanted in the wafer. Immediately after switch 58 opens, the voltage on the platen
15 begins to fall, eventually collapsing the plasma sheath in the chamber 12 that provides ions capable of being implanted into the wafer. For example, for a plasma having an ion density of $10^{10}/\text{cm}^3$, and a 5 μsec high voltage pulse of -5 kV , the minimum time for sheath collapse is 6 μsec , so implantation may occur for up to 6 μsec after the switch 58 opens.

20 If the fall time of the residual voltage is more than 6 μsec , substantial energy spread occurs. Specifically, it has been found that for a -5 kV pulse having a fall time of 20 μsec , only about 25% of the implanted ions are implanted at high voltage. As a result of this extended fall time, the resulting plasma energy distribution is non-uniform. Switch 66, however, if closed approximately 1 μsec after
25 switch 58 opens, insures a rapid fall time for the high voltage on the platen by biasing the platen to a voltage at or below the plasma potential (typically between $+10$ to $+20$ volts). The implantation process thereby stops, minimizing ion energy spread in the implant. Furthermore, the energy spread is independent of plasma conditions, such as plasma density.

30 In addition to improving the implant energy distribution, the switch 66 is also used to reduce wafer charging that might otherwise damage circuitry thereon. First, biasing the platen 24 with platen bias supply 56 neutralizes the surface of the

wafer W to prevent accumulation of positive charge which would otherwise result from ions in the plasma being implanted into insulated structures (layers) in the wafer substrate. Such charge accumulation could damage wafer circuitry by permitting a large potential difference to grow between the insulated layer and the substrate. Positively biasing the platen in between implant pulses increases the available electron current, causing electrons in the plasma to be attracted to and neutralize the positively charged insulated layer of the wafer.

In addition, positively biasing the platen prevents wafer charging that would otherwise occur when the plasma that surrounds the wafer W in the chamber 12 charges the insulating layers of the wafer to the plasma potential. Biasing the platen to at or near the plasma potential prevents a large voltage differential from developing between the insulating layer and the wafer substrate. As such, plasma-induced voltage stress on the insulating layer is prevented, thereby protecting the wafer circuitry.

The effects of deposition and sputtering are controlled in the system 10 by means of the master implant controller 52. Deposition is controlled by (i) not subjecting the wafer W to unnecessary exposure to plasma prior to the first implant pulse and by (ii) minimizing the time that the wafer W spends in the plasma between subsequent implant pulses. The implant controller 52 minimizes initial exposure of the wafer W to the plasma by simultaneously sending a first control signal 72 to the oscillator power supply 46 and a second control signal 74 to the platen voltage switching mechanism 67. In this manner, the plasma within the chamber 12 is ignited substantially simultaneously with the closing of switch 58.

The implant controller 52 minimizes the time that the wafer W spends in the plasma between subsequent implant pulses by maximizing the duty cycle of the high voltage implant pulse. The high voltage implant pulse duty cycle is defined by a third control signal 76 which determines or varies the duration of the high voltage pulse and a fourth control signal 78 which determines or varies the time between pulses. The fourth control signal is output by the controller 52 based on the output signal 80 of charge controller 54. By minimizing the time between implant pulses, the wafer is exposed to a minimal amount of plasma ion current and neutral flux between pulses. In order to accomplish this without charging damage, the

positive bias applied to the platen between implant pulses provides the necessary increase in neutralizing electron current.

The deposition effect may also be lessened by reducing the number of atomic dopant neutrals dissociated by the plasma. The number of neutrals can be reduced by increasing the gas pressure of the plasma. A reduction in gas pressure decreases the electron temperature of the plasma which in turn decreases the degree of dissociation. The number of neutrals can also be lessened by increasing the flow of gas and increasing pumping within the plasma chamber, while maintaining the same pressure, thereby reducing gas residence time within the chamber. Such a reduction in residence time reduces the degree of molecular dissociation of the gas. For example, in the case of a plasma based on BF_2 gas, the amount of boron (B) is decreased relative to the BF_2 ion that is implanted.

Sputtering, on the other hand, is controlled by minimizing the duration of the high voltage implant pulses and maximizing the time between pulses (during which the platen is positively biased). The implant controller can be programmed, therefore, to minimize sputtering during the implant process. However, decreasing sputtering (by minimizing the duty cycle of the modulated high voltage implant pulse) necessarily increases deposition during the process. Conversely, decreasing deposition (by maximizing the duty cycle of the modulated high voltage implant pulse) necessarily increases sputtering during the process. We have found that an acceptable range of deposition and sputtering can be achieved by varying the pulse width between 2 and 200 microseconds, and a pulse repetition frequency of between .5 and 5 kHz.

The goal in a precisely controlled implant process is to achieve a high retained implant dose, especially at shallow depths, without excessive sputtering or deposition. In the present invention, the implant controller enables such precise control by (i) outputting control signals 72 and 74 to simultaneously ignite the plasma and begin the implant and (ii) outputting control signals 76 and 78 to define the duty cycle of the implant pulse.

Figure 3 shows an alternative embodiment of the control system 50, referenced as 50B. The control system 50B of Figure 3 is similar to the control system 50 of Figure 2, except that the charge controller 54B controls and varies the

magnitude of the bias voltage applied by platen bias supply 56 to the platen between implant pulses, via bias control signal 84, rather than the time between pulses. Charge controller 54B outputs bias signal 84 based on the output signal 86 of platen current sensor 88, which detects platen current feedback signal 90.

5 It is contemplated that dose/current feedback mechanisms disclosed in control systems 50 and 50B may be used alternatively. For example, the dose feedback signal 43 from the current collector 42 of Figure 2 may be used in control system 50B, instead of the output signal 86 of platen current sensor 88 shown in Figure 3. Similarly, the output signal 86 of platen current sensor 88 in control
10 system 50B may be used as the input to charge controller 54 in control system 50 (rather than the dose feedback signal 43 from current collector 42).

The dose/current feedback mechanisms implemented in system 10 are known in the art. For example, an inductive coupler may be used for the current sensor 88 in Figure 3. Also, in Figure 2, the Faraday cup 42 may be implemented
15 as a capacitor formed by the platen and a plate positioned thereabove, with an insulator (dielectric) therebetween. The voltage on the capacitor is monitored to provide an indication of the charge on the wafer.

Accordingly, a preferred embodiment has been described for a mechanism for controlling the effects of sputtering and deposition in a plasma
20 immersion ion implantation system. In addition, the mechanism provides for a uniform implant energy distribution, and minimizes charge accumulation of a substrate implanted by the ion implantation system. With the foregoing description in mind, however, it is understood that this description is made only by way of example, that the invention is not limited to the particular embodiments described
25 herein, and that various rearrangements, modifications, and substitutions may be implemented with respect to the foregoing description without departing from the scope of the invention as defined by the following claims and their equivalents. In particular, it is contemplated that the master implant controller 52 may be embodied in one or more control elements, and that the control signals 72, 74, 76, 78 and 84
30 may be provided in the form of separate signals, a single multiplexed signal, or any combination thereof.

Claims:

1. In a pulsed plasma immersion ion implanter (10) having a process chamber (12) for implanting substrates (W) positioned on a platen (14) contained therein with ions present in a plasma generated therein, an implant control system (50) comprising:
 - 5 (i) a master implant controller (52) for outputting a first control signal (72) to a power supply (46) responsible for generating power necessary for igniting the plasma, and a second control signal (74) to a modulator (35) for applying a first of a series of high voltage implant pulses to the platen (14), wherein said first and second control signals are issued by said master implant controller substantially
10 simultaneously; and
 - (ii) a platen bias supply (56) for applying a bias voltage to said platen intermediate successive high voltage implant pulses.
2. The implant control system (50) of claim 1, wherein said master implant controller (52) further outputs a third control signal (76) for determining periods of time during which said successive high voltage implant pulses are applied to said platen.
3. The implant control system (50) of claim 2, wherein said master implant controller (52) further outputs a fourth control signal (78) for determining and varying periods of time intermediate times during which said successive high voltage implant pulses are applied to said platen.
4. The implant control system (50) of claim 3, wherein said bias voltage applied to said platen is approximately 0 (zero) to +20 (twenty) volts.
5. The implant control system (50) of claim 4, wherein said bias voltage applied to said platen is approximately the plasma potential.

6. The implant control system (50) of claim 3, wherein said fourth control signal (78) is issued by said master implant controller (52) in response to an output signal (80) of a charge controller (54).

7. The implant control system (50) of claim 6, wherein said charge controller (54) receives a dose feedback signal (43) from a current collector (42) located proximate the wafer (W) in the chamber (12).

8. The implant control system (50) of claim 3, wherein said fourth control signal (78) is issued by said master implant controller (52) in response to an output signal (86) of a platen current sensor (88) that detects a platen current feedback signal (90).

9. The implant control system (50) of claim 2, further comprising a charge controller (54B) for outputting a bias control signal (84) for controlling the magnitude of the bias voltage applied to the platen (14) by platen bias supply (56).

10. The implant control system (50) of claim 9, wherein charge controller (54B) outputs bias control signal (84) in response to an output signal (86) of a platen current sensor (88) that detects a platen current feedback signal (90).

11. A plasma immersion ion implantation system (10), comprising:
(i) a process chamber (12) for implanting substrates (W) positioned on a platen (14) contained therein, with ions present in a plasma generated therein;

5 (ii) a first power supply (33) for supplying a pulsed voltage signal to said platen (14);

(iii) a second power supply (46) for generating power necessary for igniting the plasma;

10 (iv) a master implant controller (52) for outputting a first control signal (72) to said power supply (46), and a second control signal (74) to a modulator (35) for applying a first of a series of high voltage implant pulses from

said first power supply (33) to the platen (14), wherein said first and second control signals are issued by said master implant controller substantially simultaneously; and

- 15 (v) a platen bias supply (56) for applying a bias voltage to said platen intermediate successive high voltage implant pulses.

12. The plasma immersion ion implantation system (10) of claim 11, wherein said master implant controller (52) further outputs a third control signal (76) for determining periods of time during which said successive high voltage implant pulses are applied to said platen.

13. The immersion ion implantation system (10) of claim 12, wherein said master implant controller (52) further outputs a fourth control signal (78) for determining and varying periods of time intermediate times during which said successive high voltage implant pulses are applied to said platen.

14. The plasma immersion ion implantation system (10) of claim 13, wherein said bias voltage applied to said platen is approximately 0 (zero) to +20 (twenty) volts.

15. The plasma immersion ion implantation system (10) of claim 14, wherein said bias voltage applied to said platen is approximately the plasma potential.

16. The plasma immersion ion implantation system (10) of claim 13, wherein said fourth control signal (78) is issued by said master implant controller (52) in response to an output signal (80) of a charge controller (54).

17. The plasma immersion ion implantation system (10) of claim 16, wherein said charge controller (54) receives a dose feedback signal (43) from a current collector (42) located proximate the wafer (W) in the chamber (12).

18. The plasma immersion ion implantation system (10) of claim 13, wherein said fourth control signal (78) is issued by said master implant controller (52) in response to an output signal (86) of a platen current sensor (88) that detects a platen current feedback signal (90).

19. The plasma immersion ion implantation system (10) of claim 12, further comprising a charge controller (54B) for outputting a bias control signal (84) for controlling the magnitude of the bias voltage applied to the platen (14) by platen bias supply (56).

20. The plasma immersion ion implantation system (10) of claim 19, wherein charge controller (54B) outputs bias control signal (84) in response to an output signal (86) of a platen current sensor (88) that detects a platen current feedback signal (90).

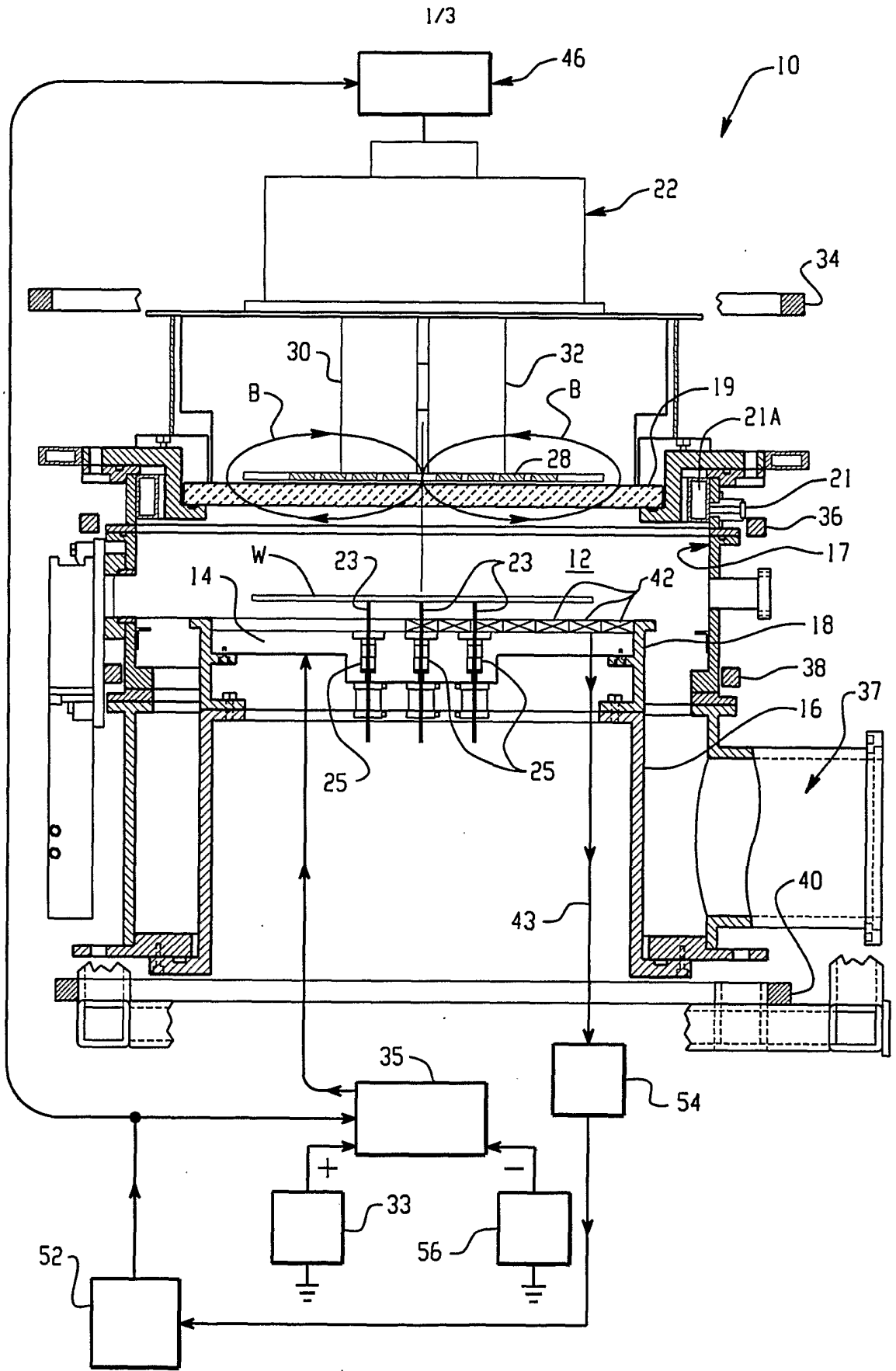

Fig. 1

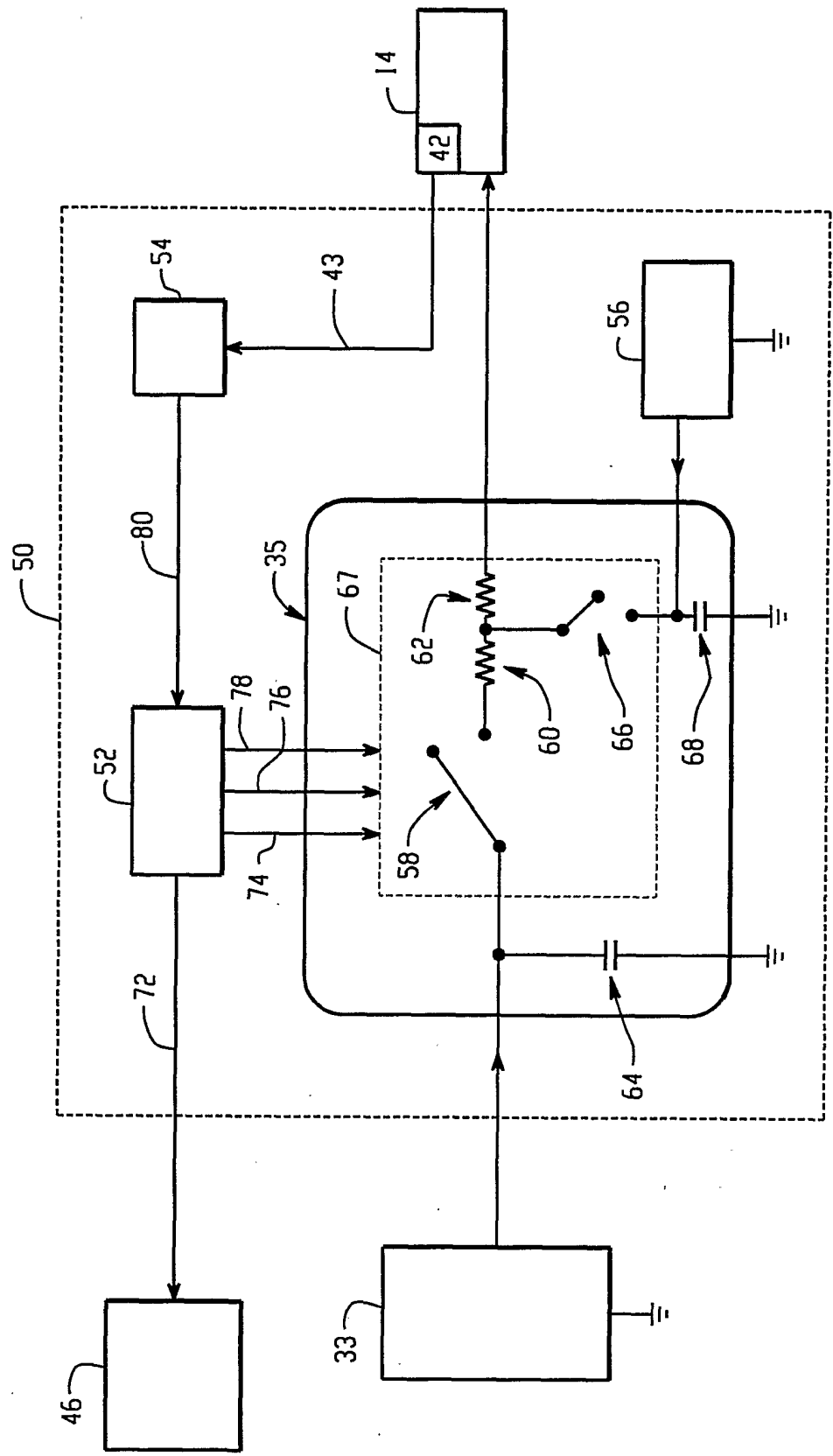

Fig. 2

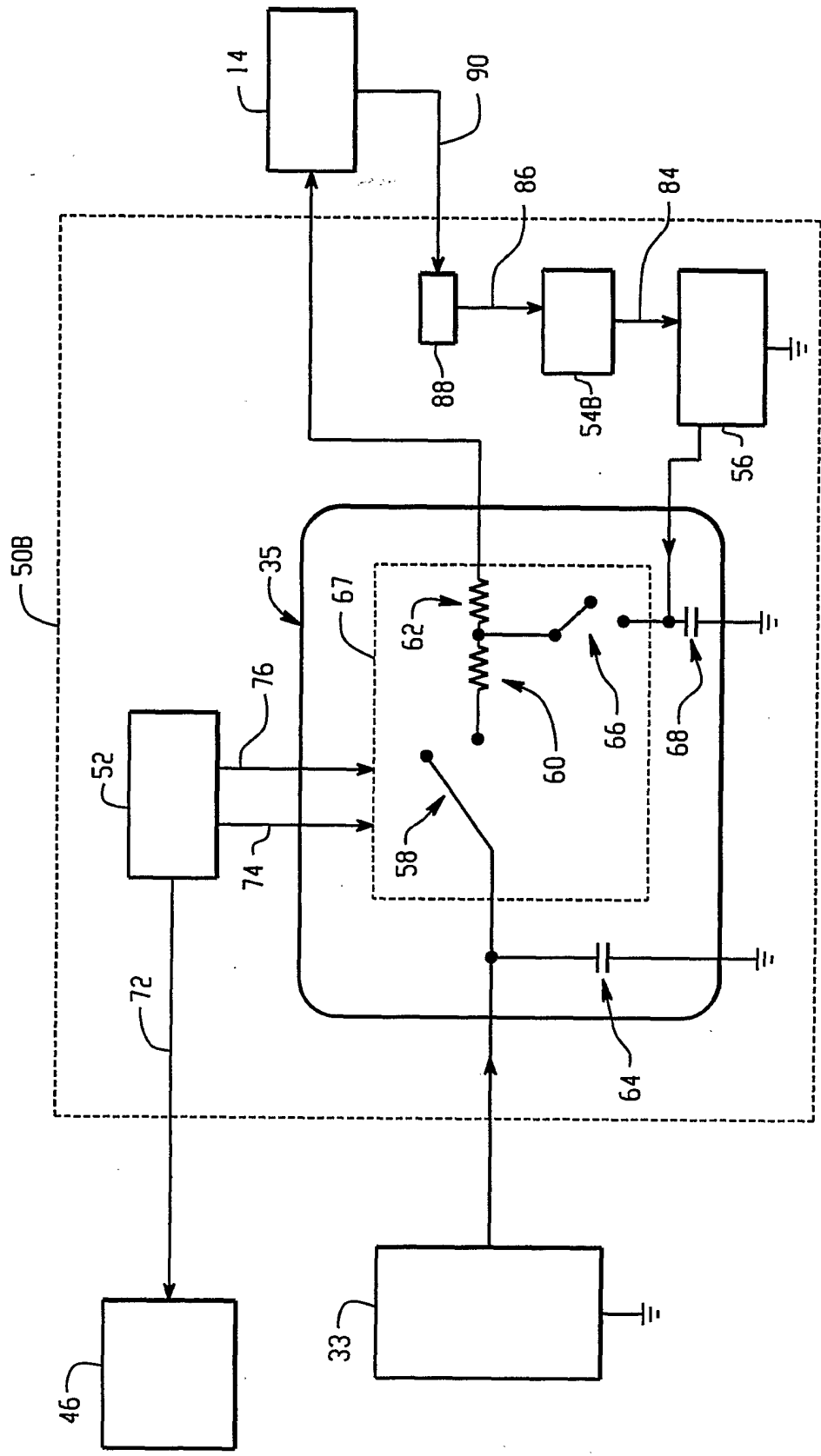

Fig. 3