

(19) **DANMARK**

(10) **DK/EP 3499661 T3**



Patent- og
Varemærkestyrelsen

(12) **Oversættelse af
europæisk patentskrift**

-
- (51) Int.Cl.: **H 02 G 1/08 (2006.01)** **F 16 G 11/06 (2006.01)** **H 02 G 1/10 (2006.01)**
- (45) Oversættelsen bekendtgjort den: **2020-06-02**
- (80) Dato for Den Europæiske Patentmyndigheds bekendtgørelse om meddelelse af patentet: **2020-04-08**
- (86) Europæisk ansøgning nr.: **18204415.6**
- (86) Europæisk indleveringsdag: **2018-11-05**
- (87) Den europæiske ansøgnings publiceringsdag: **2019-06-19**
- (30) Prioritet: **2017-12-12 NL 2020068**
- (84) Designerede stater: **AL AT BE BG CH CY CZ DE DK EE ES FI FR GB GR HR HU IE IS IT LI LT LU LV MC MK MT NL NO PL PT RO RS SE SI SK SM TR**
- (73) Patenthaver: **B.V. Twentsche Kabelfabriek, Spinnerstraat 15, 7481 KJ Haaksbergen, Holland**
- (72) Opfinder: **ROELOFS, Rob, c/o B.V. Twentsche Kabelfabriek, Spinnerstraat 15, 7481 KJ Haaksbergen, Holland**
WESSELS, Werner Alexander, c/o B.V. Twentsche Kabelfabriek, Spinnerstraat 15, 7481 KJ HAAKSBERGEN, Holland
- (74) Fuldmægtig i Danmark: **Holme Patent A/S, Valbygårdsvej 33, 2500 Valby, Danmark**
- (54) Benævnelse: **Trækkonstruktion og fremgangsmåde til trækning af et undersøisk kabel**
- (56) Fremdragne publikationer:
EP-A1- 1 953 882
GB-A- 2 142 788
GB-A- 2 169 993
US-B1- 9 027 908

DESCRIPTION

BACKGROUND

[0001] The invention relates to a pulling assembly and a method for pulling a submarine cable an example of which is shown in GB 2 169 993 A.

[0002] DE 42 00 865 A1 discloses a cable drawing device with a cable sock - also known as a 'Chinese finger grip' - which is tightened around the outer sheath of the cable by pulling in the longitudinal direction of the cable. The end of the cable is stripped to expose a traction cord with a number of traction-resistant strands. The cable sock is attached to a pulling eye via a sleeve. The traction-resistant strands are received into a central bore of the sleeve and a conical wedge is propelled into said central bore from the opposite side to fix the traction-resistant strands between said wedge and the sleeve. The known cable drawing device has the advantage that the pulling load at the pulling eye is not exerted on the sheathing which is not traction-resistant. Instead, the pulling load can be taken up entirely by the traction-resistant strands between the central wedge and the sleeve.

SUMMARY OF THE INVENTION

[0003] The known cable drawing device is arranged for taking the pulling load in the longitudinal direction of the cable, i.e. for pulling the cable in a straight line. On many occasions however, the cable has to be pulled through or around a bend, e.g. when coiling the cable in a factory, when pulling the cable through cable guides in the factory, when pulling the cable from the factory into a transport vessel, when laying the cable from transport vessel onto the seabed and/or when pulling the cable from the seabed into the tower of an offshore windmill. The known cable drawing device is not adapted for taking the transverse pulling loads that occur during the pulling of the cable around a bend and will be pulled sideways with respect to the cable or may even be torn of. Meanwhile the stiffness in the cable causes said cable to continue on its own path, possibly colliding with and/or getting stuck behind obstacles.

[0004] It is an object of the present invention to provide a pulling assembly and method for pulling a submarine cable around a bend.

[0005] According to a first aspect, the invention provides a pulling assembly for pulling a submarine cable, wherein the submarine cable has a longitudinal direction, wherein the pulling assembly comprises a pulling member facing in a terminal direction for connection to an external pulling means and a coupling member for coupling of the pulling assembly to the submarine cable, wherein the coupling member is provided with an open first end for receiving a stripped end of the submarine cable in a receiving direction in line with the longitudinal direction of said submarine cable, wherein the pulling assembly further comprises a guiding

member that extends from a second end of the coupling member opposite to the first end of the coupling member to the pulling member, wherein the guiding member is flexible between a straight state in which the guiding member extends over a guiding length along a straight line between the pulling member and the second end of the coupling member and a bend state in which the guiding member extends along a bend line between the pulling member and the second end of the coupling member, wherein the guide member in the bend state has a minimum bending angle between the terminal direction and the receiving direction of at least twenty degrees per meter of the guiding length.

[0006] The guiding member is located in front of the stripped end of the submarine cable and will arrive at the bend first. When a pulling force is applied to the pulling member in a pulling direction transverse to the longitudinal direction of the submarine cable, the guiding member can move from the straight state towards the bend state to at least partially flex in the direction of the pulling force. In the bend state, the guiding member can function as a guide for guiding the trailing submarine cable around the bend.

[0007] Preferably, the minimum bending angle is at least thirty degrees per meter of the guiding length, and preferably is at least forty-five degrees per meter of the guiding length. A higher minimum bending angle means that the guiding member can be bent to a smaller radius and thus can guide the submarine cable along tighter bends. Similarly, the bend line can have a minimum radius in the range of one to three meters, and preferably in the range of one-and-a-half to two-and-a-half meters.

[0008] Alternatively, the guiding member in the bend state has a maximum bending angle of less than seventy degrees per meter of the guiding length, and preferably less than sixty degrees per meter of the guiding length. By restricting the bending angle to a maximum bending angle, it can be prevented that the guiding member is bent to a bend state that exceeds the flexibility and/or tensile strength of the submarine cable. Moreover, when said maximum bending angle has been reached, the guiding member may function as a lever for exerting a bending moment on the submarine cable. Said bending moment may cause the submarine cable to bend, which can make the pulling of the submarine cable around bends easier.

[0009] In another embodiment the guiding member within the flexible range between the straight state and the bend state is capable of exerting a bending moment on the coupling member at the open first end thereof of at least three kNm, and preferably of at least four kNm. The guiding member can thus act as a lever for exerting the bending moment of the submarine cable. Said bending moment may cause the submarine cable to bend, which can make the pulling of the submarine cable around bends easier. It has been found that a bending moment of at least three kNm is enough to bend a typical submarine cable with a Young's modulus of approximately six kNm² around a bend with a radius of approximately two meters. The guiding member may be capable of exerting said bending moment as a result of its bending stiffness, its flexural rigidity or when the maximum bending angle has been reached.

[0010] In another embodiment the pulling assembly further comprises a tensioning member for tensioning the guiding member in a tensioning direction. By tensioning the guiding member, the bending stiffness, flexural rigidity and/or maximum bending angle of said guiding member can be set.

[0011] In a preferred embodiment thereof the tensioning direction extends parallel, radially or circumferentially with respect to the straight line when the guiding member is in the straight state. The tensioning direction can influence the behaviour of the guiding member, in particular the way in which it is capable of transmitting the pulling force from the pulling member onto the coupling member. When the tensioning direction is parallel to the straight line, the pulling forces can be transmitted through the heart of the guiding member. When the tensioning direction is radially or circumferentially, the pulling forces can be effectively transmitted along the circumference or around the outer surface of the guiding member.

[0012] In the previously described embodiment, the tensioning member is described as being part of the pulling assembly. However, the tensioning member may alternatively be supplied separately from the pulling assembly, in which case the pulling assembly is merely provided with a first tensioning mount at or near the pulling member and a second tensioning mount at or near the coupling member, wherein the guiding member is provided with an hollow cavity extending along the straight line in the straight state of the guiding member from the first tensioning mount to the second tensioning mount for mounting a tensioning member between the first tensioning mount and the second tensioning mount. Hence, the tensioning member can be accommodated fully within the guiding member.

[0013] In an embodiment thereof the position of one of the first tensioning mount and the second tensioning mount is adjustable along the straight line with respect to the other of the first tensioning mount and the second tensioning mount for adjusting the tension in the tensioning member. By adjusting the tension, the bending stiffness, flexural rigidity and/or maximum bending angle of the guiding member can be adjusted to match the requirements of the pulling assembly.

[0014] In a further embodiment thereof the tensioning member, the first tensioning mount and the second tensioning mount have a load limit of at least four kN, and preferably of at least five kN. It has been found that a pulling force of at least four kN can effectively pull the submarine cable around a bend. Hence, the tensioning member and its mounts should at least be able to withstand such loads.

[0015] Preferably, the aforementioned tensioning member is a chain. A chain is sufficiently strong to withstand the loads as a result of the pulling, while it is also capable of following the bending of the guiding member between the straight state and the bend state.

[0016] In another embodiment the guiding member comprises a plurality of rigid segments which are interconnected to form articulating vertebrae extending along the straight line in the straight state of the guiding member. The rigid segments can be designed to be sufficiently

strong to withstand the considerable forces involved with pulling a submarine cable, while the articulation allows for the guiding member to flex.

[0017] In an embodiment thereof the plurality of rigid segments are arranged to abut each other in the bend state to restrict the articulation of the vertebrae to a maximum bending angle between the terminal direction and the receiving direction of less than seventy degrees, and preferably less than sixty degrees. Again, by restricting the bending angle to a maximum bending angle, it can be prevented that the guiding member is bend to a bend state that exceeds the flexibility and/or tensile strength of the submarine cable. Moreover, when said maximum bending angle has been reached, the guiding member may function as a lever for exerting a bending moment on the submarine cable. Said bending moment may cause the submarine cable to bend, which can make the pulling of the submarine cable around bends easier.

[0018] In a further embodiment thereof the guiding member further comprises a flexible segment between each pair of adjacent rigid segments for limiting the articulation of between said pair of adjacent rigid segments. The flexible segment can provide the resilient compression between the rigid segments that allows the guiding member to flex back to the straight state when the pulling force is no longer applied to the pulling member.

[0019] Preferably, said pair of adjacent rigid segments is concentrically connected to each other, wherein the flexible segment is ring-shaped to extend around the concentric connection between said pair of adjacent rigid segments. Hence, the flexible segment can be fitted between the rigid segments without interfering with the connection between said rigid segments.

[0020] In a further preferred embodiment thereof the flexible segments consist of or comprise a resilient material, preferably a resilient elastomeric material.

[0021] In yet another embodiment the guiding member tapers from the coupling member towards the pulling member. Preferably, the guiding member tapers conically from the coupling member towards the pulling member. Hence, the guiding member can taper from the diameter of the coupling member towards the smaller diameter of the pulling member. A conical tapering means that the guiding member can be relatively smooth and is therefore less likely to get stuck behind obstacles.

[0022] In a further embodiment the submarine cable comprises one or more insulated, electrically conductive cores and a cylindrical or substantially cylindrical protective sheathing surrounding said one or more cores, wherein the coupling member comprises a cylindrical coupling sleeve for concentrically connecting to and circumferentially contacting said protective sheathing. Hence, a strong grip and/or connection can be obtained between the coupling sleeve and the protective sheathing.

[0023] In a preferred embodiment thereof the submarine cable further comprises armouring

between the protective sheathing and the one or more cores, wherein the armouring comprises a plurality of armour wires and wherein at least some of the armour wires are exposed with respect to the protective sheathing at the stripped end of the submarine cable, wherein the coupling member comprises a wire fixation tool for receiving and fixating at least some of the exposed armour wires in the receiving direction with respect to the wire fixation tool, wherein the wire fixation tool is operationally connected to the coupling sleeve for positioning the coupling sleeve with respect to the fixated armour wires. Hence, the positioning of the coupling sleeve with respect to the fixated armour wires can be fixated to obtain a strong coupling that is able to transmit the pulling force onto the armour wires of the submarine cable.

[0024] Preferably, the coupling member further comprises a tightening element for tightening the coupling sleeve in a tightening direction opposite to the receiving direction towards and/or over the protective sheathing of the submarine cable. By tightening the coupling sleeve, a forceful and/or pressing abutment can be obtained, that can have some sealing effect.

[0025] More preferably, the coupling member comprises a threaded rod extending from the wire fixation tool in the receiving direction towards the second end of the coupling member, wherein the coupling member is provided with an end cap that is slidable over the threaded rod in the tightening direction, wherein the tightening element is a nut engaging with the threaded rod in the tightening direction from an opposite side of the end cap with respect to the wire fixation tool for tightening the end cap with respect to the wire fixation tool. The nut can be easily tightened with the use of readily available tools.

[0026] In an embodiment thereof the end cap is integrally formed with or fixated relative to the coupling sleeve. Alternatively, the end cap and the coupling sleeve are separate and wherein the end cap is arranged to abut the coupling sleeve in the tightening direction.

[0027] According to a second aspect, the invention provides a method for pulling a submarine cable with the use of the pulling assembly according to any one of the aforementioned embodiments, wherein the method comprises the steps of:

- stripping an end of the submarine cable to obtain the stripped end;
- receiving the stripped end of the submarine cable in the receiving direction in line with the longitudinal direction of said submarine cable in the open first end of the coupling member;
- connecting the pulling member to an external pulling means in the terminal direction;
- exerting a pulling force on the pulling member with the use of the external pulling means to pull the submarine cable; and
- flexing the guiding member from the straight state into the bend state to pull the submarine cable around a bend.

[0028] The method relates to the practical implementation of the pulling member according to the first aspect of the invention. Hence, the method and its embodiments have the same

technical effects, which will not be repeated hereafter.

[0029] In a preferred embodiment the method further comprises the step of flexing the guiding member in the flexible range between the straight state and the bend state and thereby exerting a bending moment on the coupling member at the open first end thereof of at least three kNm, and preferably of at least four kNm.

[0030] In a further embodiment of the method the submarine cable comprises one or more insulated, electrically conductive cores and a cylindrical or substantially cylindrical protective sheathing surrounding said one or more cores, wherein the coupling member comprises a cylindrical coupling sleeve, wherein the method further comprises the step of concentrically connecting the coupling sleeve to and in contact with said protective sheathing.

[0031] Preferably, the armouring comprises a plurality of armour wires and wherein at least some of the armour wires are exposed with respect to the protective sheathing at the stripped end of the submarine cable, wherein the coupling member comprises a wire fixation tool, wherein the method further comprises the steps of receiving and fixating at least some of the exposed wires in the receiving direction in the wire fixation tool and operationally connecting the wire fixation tool to the coupling sleeve for positioning the coupling sleeve with respect to the fixated armour wires.

[0032] In a further embodiment the method further comprises the step of tightening the coupling sleeve in a tightening direction opposite to the receiving direction towards and/or over the protective sheathing of the submarine cable.

[0033] In a further embodiment the method further comprises the step of providing one or more first watertight seals between the coupling member and the stripped end of the submarine cable to seal said stripped end from water. Hence, water ingress into the cores of the submarine cable can be prevented.

[0034] Additionally or alternatively, the method further comprises the step of providing one or more second watertight seals between the coupling member and guiding member to seal the coupling member from water. Hence, water ingress into the cores of the submarine cable can be prevented.

[0035] The various aspects and features described and shown in the specification can be applied, individually, wherever possible. These individual aspects, in particular the aspects and features described in the attached dependent claims, can be made subject of divisional patent applications.

BRIEF DESCRIPTION OF THE DRAWINGS

[0036] The invention will be elucidated on the basis of an exemplary embodiment shown in the

attached schematic drawings, in which:

figure 1 shows a side view of a pulling assembly for pulling a submarine cable according to a first embodiment of the invention;

figure 2 shows a cross section of the pulling assembly according to line II-II in figure 1;

figure 3 shows a cross section of the pulling assembly according figure 2 in a bend state;

figure 4 shows a side view of an end of the submarine cable after said end has been stripped to expose a plurality of armour wires;

figures 5, 6 and 7 show in cross section the steps of a method for mounting the pulling system to the stripped end of the submarine cable of figure 4;

figure 8 shows a cross section of the submarine cable according to line VIII-VIII in figure 5;

figure 9 shows a cross section of the submarine cable with the pulling assembly according to line IX-IX in figure 5;

figure 10 shows a cross section of the submarine cable with the pulling assembly according to figure 9 with additional sealing elements;

figure 11 shows a side view of an alternative pulling assembly for pulling a cable submarine according to a second embodiment of the invention; and

figures 12, 13 and 14 show in cross section the steps of a method for mounting the pulling system to the stripped end of the submarine cable of figure 11.

DETAILED DESCRIPTION OF THE INVENTION

[0037] Figure 1 shows a pulling assembly 1 for pulling a submarine cable 9 through and/or around a bend according to a first exemplary embodiment of the invention.

[0038] As shown in cross section in figure 8, the submarine cable 9 in this example comprises three insulated, electrically conductive cores 91, 92, 93 and a cylindrical or substantially cylindrical protective sheathing 94, surrounding said cores 91-93. Preferably the protective sheathing 94 consists of or comprises Polyethylene (PE). The submarine cable 9 further comprises armouring 95 between the protective sheathing 94 and the cores 91, 92, 93. The armouring 95 comprises a plurality of armour wires 96. Optionally, the submarine cable 9 may comprise fillers 97 and an optical fibre core 98. Said submarine cable 9 may for instance be used in long-distance applications, e.g. in offshore wind farms. It will be apparent to one skilled in the art that the pulling assembly 1 according to the present invention may be used in combination with different cable configurations, e.g. a single core submarine cable. As shown

in figure 1, the submarine cable 9 has a central axis or centre line S extending in or defining a longitudinal direction X of the submarine cable 9. As shown in figure 4, an end of the submarine cable 9 has been stripped to obtain a stripped end 99. At least some of the armour wires 96 extend or project from the protective sheathing 94, thereby exposing said armour wires 96. In this exemplary embodiment, a number of armour wires 96 have been cut-off at the end of the protective sheathing 94 so that a limited number of armour wires 96, e.g. less than half of all the armour wires 96, remain exposed.

[0039] As shown in figure 1, the pulling assembly 1 comprises a pulling member 2 facing in a terminal direction A for connection to an external pulling means (not shown). The pulling assembly 1 further comprises a coupling member 3 for coupling of the pulling assembly 1 to the stripped end 99 of the submarine cable 9 in a manner that will be described in more detail hereafter. Between the pulling member 2 and the coupling member 3, the pulling assembly 1 is provided with a guiding member 4 for guiding the submarine cable 9 through or along a bend.

[0040] As best seen in figure 1, the pulling member 2 comprises a pulling eye 21 for connecting to the external pulling means in the terminal direction A and a swivel base 22 for connecting said pulley eye 21 to the guiding member 4. The pulling eye 21 can be swivelled with respect to the swivel base 22 in the pulling direction P of the external pulling means. The pulling direction P may thus deviate from the terminal direction A in order to exert a transverse pulling force on the pulling assembly 1 to pull the submarine cable 9 through and/or along a bend.

[0041] The coupling member 3 is provided with an open first end 31 for receiving the stripped end 99 of the submarine cable 9 in a receiving direction B in line with or parallel to the longitudinal direction X of said submarine cable 9. In particular, as best seen in the cross section of figure 6, the coupling member 3 comprises a cylindrical coupling sleeve 33 with a circumferential edge 34 that defines said open first end 31. The coupling sleeve 33 is arranged to be slid over the stripped end 99 of the submarine cable 9, concentrically with respect to the centre line S thereof, until the circumferential edge 34 contacts the protective sheathing 94. Preferably, the coupling sleeve 33 consists of or comprises a rigid material, e.g. stainless steel. In this exemplary embodiment, the coupling sleeve 33 extends over at least 0,3 meters in the receiving direction B.

[0042] As further shown in figure 6, the coupling member 3 comprises a second end 32, opposite to the first end 31, for connection to the guiding member 4. The coupling member 3 is provided with an end cap 35 at the second end 32 for closing off the coupling sleeve 34 at the side of the guiding member 4. In this exemplary embodiment, the end cap 35 is integral with the coupling sleeve 33. Alternatively, the end cap 35 may be a separate part that is fastened to and/or fixated with respect to the coupling sleeve 33, e.g. through welding. The coupling member 3 further comprises a wire fixation tool 36 for receiving and fixating at least some of the exposed armour wires 96 in the receiving direction B with respect to said wire fixation tool 36. In this exemplary embodiment, the wire fixation tool 36 comprises three groups of each five clamps 38. Each clamp 38 is arranged for simultaneously clamping two of the exposed armour

wires 96. Alternatively, different clamping configurations may be used to obtain a similar effect. The armour wires 96 are substantially traction-resistant. Hence, by fixating the exposed armour wires 96 in the wire fixation tool 36, the position of the wire fixation tool 36 relative to the submarine cable 9 in the longitudinal direction X thereof is substantially fixed.

[0043] The coupling sleeve 33 is arranged for concentrically receiving the stripped end 99 of the submarine cable 9 with the wire fixation tool 36 fixated thereon in the receiving direction B. Preferably, the wire fixation tool 36 is disc or ring shaped to concentrically fit inside the cylindrical spaced defined by the coupling sleeve 33. The wire fixation tool 36 is operationally connected to the coupling sleeve 33 for positioning the coupling sleeve 33 with respect to the fixated armour wires 96. In particular, as shown in figure 6, the coupling member 3 further comprises a tightening element 5 for tightening the coupling sleeve 33 in a tightening direction T opposite to the receiving direction towards and/or over the protective sheathing 94 of the submarine cable 9. In this exemplary embodiment, the coupling member 3 comprises a threaded rod 38 and the tightening element 5 is a nut 50 for engaging said threaded rod 38. The threaded rod 38 extends from the wire fixation tool in the receiving direction B towards the second end 32 of the coupling member 3. The end cap 35 is provided with an opening 39 that is aligned with the threaded rod 38 for sliding the end cap 35 over the threaded rod 38 in the tightening direction T. The nut 50 is arranged to engage with the threaded rod 38 in the tightening direction T from an opposite side of the end cap 35 with respect to the wire fixation tool 36 for tightening the end cap 35 with respect to the wire fixation tool 36.

[0044] As shown in figures 2 and 3, the guiding member 4 extends between the swivel base 22 of the pulling member 2 and the second side 32 of the coupling member 3. The guiding member 4 is flexible between a straight state, as shown in figure 2, in which the guiding member 4 extends over a guiding length L along a straight line V between the pulling member 2 and the second end 32 of the coupling member 3 and a bend state, as shown in figure 3, in which the guiding member 4 extends along a bend line W between the pulling member 2 and the second end 32 of the coupling member 3. The guiding length L is to be understood as the length of the guiding member 4 in the straight state of figure 2 between the second end 32 of the coupling member 3 and the swivel base 22 of the pulling member 2. In this exemplary embodiment, the guiding length is approximately one meter. Different guiding lengths L are possible depending on the guiding requirements, e.g. the gaps between consecutive obstacles that define the bend. In the bend state of figure 3, the guiding member 4 has a minimum bending angle H between the terminal direction A and the receiving direction B of at least twenty degrees per meter of the guiding length. Preferably, the minimum bending angle H is at least thirty degrees per meter of the guiding length L and most preferably at least forty-five degrees per meter of the guiding length L. At a bending angle H of at least twenty degrees, bend line W has a minimum radius R of less than three meters. Correspondingly, at a bending angle H of at least thirty degrees, the minimum radius R will be less than two meters and, at a bending angle H of at least forty-five degrees, the minimum radius R will be less than one-and-a-half meters.

[0045] The guiding member 4 according to the invention is flexible between the straight state

of figure 2 and the bend state of figure 3, meaning that the guiding member 4 is resiliently and/or elastically movable in a flexing range between said two states. When no pulling force is exerted on the pulling member 2 in the pulling direction P, the guiding member 4 will resiliently and/or elastically return to the unstressed, straight state of figure 2. The flexing range, i.e. the range within which the guiding member 4 is flexibly, elastically and/or resiliently movable without plastic deformation, is restricted to a maximum bending angle H of less than seventy degrees per meter of the guiding length L, and preferably of less than sixty degrees per meter of the guiding length L.

[0046] Preferably, the guiding member 4 has a bending stiffness or flexural rigidity, i.e. a resistance to bending, so that during the flexing a considerable bending moment M, as schematically shown in figure 3, may be exerted onto the coupling member 3 at the open first end 31 thereof. In particular, the guiding member 4 is designed such that, within the flexible range between the straight state and the bend state, it is capable of exerting a bending moment M on the coupling member 2 at the open first end 31 thereof of at least three kNm, and preferably of at least four kNm. Said bending moment M should be sufficient to at least partially bend the submarine cable 9 directly upstream of said coupling member 2.

[0047] As shown in figure 2, the guiding member 4 comprises a plurality of rigid segments 41 which are interconnected to form articulating vertebrae 40 extending along the straight line V in the straight state of the guiding member 4. In this exemplary embodiment, the guiding member 4 comprises a series of 9 interconnected rigid segments 41. Each rigid segment 41 comprises an annular body 42 and a through hole 43 extending concentrically through said annular body 42. Each rigid segment 41 further comprises a concentrically extending, annular protrusion 44 that concentrically fits in an articulating manner in the through hole 43 of an adjacent one of the rigid segments 41 to connect the pair of adjacent rigid segments 41. Preferably, the plurality of rigid segments 41 are arranged to abut each other in the bend state, as shown in figure 3, to restrict the articulation of the vertebrae 40 to the aforementioned maximum bending angle H.

[0048] Additionally or alternatively, the guiding member 4 comprises a flexible segment 45 between each pair of adjacent rigid segments 41 for limiting the articulation of said pair of adjacent rigid segments 41. Preferably, the flexible segment 45 is ring-shaped to extend around the concentric protrusion 44 between said pair of adjacent rigid segments 41. In this exemplary embodiment, the flexible segments 45 consist of or comprise a resilient and/or compressible material, preferably a resilient and/or compressible elastomeric material like Polyurethane (PU). The compressibility of the flexible segments 45 defines the extent of the flexibility of the articulating vertebrae 40.

[0049] As shown in figure 2, the guiding member 4 tapers from the coupling member 3 towards the pulling member 2. Preferably, the guiding member 4 tapers conically from the coupling member 3 towards the pulling member 2. In particular, the guiding member 4 tapers from the diameter of the coupling member 3 and/or the submarine cable 9 to the smaller diameter of the pulling member 2. Hence, the guiding member 4 can be relatively smooth

and/or without abrupt transitions.

[0050] In the exemplary embodiment of figure 2, the pulling assembly 1 further comprises a tensioning member 6 for tensioning the guiding member 4 in the straight state in a tensioning direction Z parallel to the straight line V. More in particular, the pulling assembly 1 is provided with a first tensioning mount 71 at or near the pulling member 2 and a second tensioning mount 72 at or near the coupling member 3. The through holes 43 in the rigid segments 41 of the guiding member 4 form a hollow cavity extending along the straight line V in the straight state of the guiding member 4 from the first tensioning mount 71 to the second tensioning mount 72. Hence, the tensioning member 6 can be mounted between the first tensioning mount 71 and the second tensioning mount 72 and extend through the hollow cavity at the heart of the guiding member 4. Preferably, the position of the first tensioning mount 71 is adjustable along the straight line V with respect to the second tensioning mount 72 for adjusting the tension in the tensioning member 6. In this example, the first tensioning mount 71 is coupled to the pulling member 2, which is provided with a thread and which is arranged to engage with a threaded inside of the last rigid segment 41. Hence, by rotating the pulling member 2 with respect to the last rigid segment 41, the position of the pulling member 2 and the first tensioning mount 71 connected thereto can be adjusted.

[0051] Preferably, the tensioning member 6, the first tensioning mount 71 and the second tensioning mount 72 have a load limit of at least four kN, and preferably of at least five kN. In this exemplary embodiment, the tensioning member 6 is a chain.

[0052] A method for pulling the submarine cable 9 through and/or along a bend with the use of the aforementioned pulling assembly 1 will now briefly be described with reference to figures 1-10.

[0053] In the situation of figure 4, an end of the submarine cable 9 has been stripped to obtain the stripped end 99 in the manner as described before. Figures 5, 6 and 7 show the consecutive steps of coupling the coupling member 3 to said stripped end 99. In particular, figure 5 shows the situation in which the exposed armour wires 96 are received and fixed in the wire fixation tool 36 in the manner as described before. Subsequently, as shown in figure 6, the coupling sleeve 33 is slid over the stripped end 99 of the submarine cable 9 and the wire fixation tool 36 attached thereto. The opening 39 in the end cap 35 is aligned with and slid over the threaded rod 38. Subsequently, as shown in figure 7, the tightening element 5 in the form of the nut 50 is mounted on the opposite side of the threaded rod 38 with respect to the wire fixation tool 36. The nut 50 is then tightened in the tightening direction T to force the coupling sleeve 33 into contact with and/or over the protective sheathing 94. In particular, the protective sheathing 94 is compressed slightly inwards upon contact with the circumferential edge 94 to allow for the coupling sleeve 33 to move over the protective sheathing 94 (schematically shown in figure 7 with arrow C). Hence, a reliable watertight sealing between the coupling sleeve 33 and the submarine cable 9 can be obtained.

[0054] With the coupling member 3 now coupled to the stripped end 99 of the submarine cable

9, the guiding member 4 can be assembled in front of said coupling member 3. In particular, the first rigid segment 41 of figure 2 is placed downstream of the end cap 35 of the coupling member 3. The first rigid segment 41 may be placed in direct contact with the end cap 35 or with interposition of an intermediate flexible segment 42 between the end cap 35 and the coupling member 3. Subsequently, the rest of the rigid segments 41 and their interposed flexible segments 42 is assembled right up to the position where the pulling member 2 is to be attached. Prior, during or after assembly of the guiding member 4, the tensioning member 6 is assembled and/or inserted and connected to the second tensioning mount 72. Once the guiding member 4 has been fully assembled and the tensioning member 6 is located inside said assembled guiding member 4, the first tensioning mount 71 is connected to the tensioning member 6 and pulling member 2 is mounted to the end of the guiding member 4. The tensioning member 6 may now be tensioned in the aforementioned manner to adjust the bending stiffness of the guiding member 4.

[0055] Optionally, as shown in figure 10, the method further comprises the steps to further seal the pulling assembly 1 and/or the submarine cable 9 from water. In particular, one or more first watertight seals 11 may be provided between the coupling member 3 and the stripped end 99 of the submarine cable 9 to seal said stripped end 99 from water ingress. In this exemplary embodiment, the transition from the coupling member 33 to the protective sheathing 94 at the circumferential edge 34 is sealed by heat shrinking a shrink tube or shrink foil around said transition. Alternatively or additionally, one or more second watertight seals 12 may be provided between the coupling member 3 and guiding member 4 to seal the coupling member 3 from water ingress. In this exemplary embodiment, the one or more second watertight seals 12 are obtained by gluing the threaded rod 38 to the wire fixation tool 36 and/or by providing a compressible sealing layer between the end cap 35 and the wire fixation tool 36.

[0056] The pulling assembly 1 is now ready for pulling the submarine cable 9 around and/or through a bend. External pulling means (not shown) are used to exert a pulling force onto the pulling member 2 in a pulling direction P, as shown in figure 3, to pull the pulling assembly 1 from the straight state, as shown in figure 2, into the bend state, as shown in figure 3. During tests with a guiding member 4 with a guiding length L of approximately one meter and a coupling member 3 with a length of approximately 0,4 meters, it has been found that at a bending angle H of approximately fifty-five degrees, a pulling force of approximately six kN was required to exert a bending moment M via the guiding member 4 onto the coupling member 3 at the open first end 31 thereof of at least three kN. Said bending moment M was found to be sufficient to pull the submarine cable 9 around a bend with a radius R of approximately two meters.

[0057] Figure 11 shows an alternative pulling assembly 101 according to a second embodiment of the invention. Like the aforementioned pulling assembly 1, the alternative pulling assembly 101 is again provided with a guiding member 104 comprising a plurality of rigid segments 141 and a plurality of flexible segments 142. However, in this case, the flexible segments 142 have approximately the same length as the rigid segments 141. The rigid segments 141 and the flexible segments 142 are interconnected to form articulating vertebrae

140 with similar bending characteristics as in the pulling assembly 1 according to the first aspect of the invention. In this exemplary embodiment, the rigid segments 141 and the flexible segments 142 are interconnected in an articulating manner with the use of mutually engaging hooks 143, 144. The alternative pulling assembly 101 features a plurality of tensioning members 106 that - in contrast to the aforementioned single tensioning member 6 - do not extend in the longitudinal direction X through the hollow cavity in the guiding member 104. Instead, said tensioning members 106 are arranged for tensioning the flexible segments 142 in a tensioning direction Z radially and/or circumferentially with respect to the straight line V, e.g. by compressing each flexible segment 142 in said tensioning direction Z with the use of a tensioning bolt. More tension means less tolerance or free space between the mutually engaging hooks 143, 144 and thus less articulation between the rigid segments 141 and the flexible segments 142.

[0058] As shown in figures 12, 13 and 14, the alternative pulling assembly 101 further differs from the aforementioned pulling assembly 1 in that it features a coupling sleeve 103 and an end cap 135 which are separate, i.e. not integral. The end cap 135 is provided with a flange 136 that is arranged to abut the coupling sleeve 103 in the tightening direction T. When the tightening element 5 is mounted on the threaded rod 38 (figure 13), the end cap 135 is forced over said threaded rod 38 towards the wire fixation tool 36 and on its way pushes the coupling sleeve 103 towards and over the protective sheathing 94 of the submarine cable 9 (figure 14).

[0059] It is to be understood that the above description is included to illustrate the operation of the preferred embodiments and is not meant to limit the scope of the invention. From the above discussion, many variations will be apparent to one skilled in the art that would yet be encompassed by the scope of the present invention.

[0060] In summary, the invention relates to a pulling assembly 1, 101 and a method for pulling a submarine cable 9, wherein the pulling assembly 1, 101 comprises a pulling member 2 facing in a terminal direction A for connection to an external pulling means and a coupling member 3, 103 for coupling of the pulling assembly 1, 101 to the submarine cable 9, wherein the coupling member 3, 103 is provided with an open first end 31 for receiving a stripped end 99 of the submarine cable 9 in a receiving direction B in line with the longitudinal direction X of said submarine cable 9, wherein the pulling assembly 1, 101 further comprises a guiding member 4, 104 that is flexible between a straight state in which the guiding member 4, 104 extends over a guiding length L along a straight line V between the pulling member 2 and the second end 32 of the coupling member 3, 103 and a bend state in which the guiding member 4, 104 extends along a bend line W between the pulling member 2 and the second end 32 of the coupling member 3, 103.

REFERENCES CITED IN THE DESCRIPTION

This list of references cited by the applicant is for the reader's convenience only. It does not

form part of the European patent document. Even though great care has been taken in compiling the references, errors or omissions cannot be excluded and the EPO disclaims all liability in this regard.

Patent documents cited in the description

- GB2169993A [0001]
- DE4200865A1 [0002]

Krav:

1. Trækkonstruktion (1) til trækning af et undersøisk kabel (9), hvori det undersøiske kabel har en længderetning (X), hvori trækkonstruktionen (1) omfatter et trækelement (2), som vender i en tilslutningsretning (A) til forbindelse til et eksternt trækmiddel, og et koblingselement (3) til kobling af trækkonstruktionen (1) til det undersøiske kabel (9), hvori koblingselementet (3) er forsynet med en åben første ende (31) til modtagelse af en afisoleret ende (99) af det undersøiske kabel (9) i en modtageretning (B) på linje med nævnte undersøiske kabels (9) længderetning (X), **kendetegnet ved at** trækkonstruktionen (1) yderligere omfatter et styreelement (4), som strækker sig til trækelementet (2) fra en anden ende (32) af koblingselementet (3) modsat koblingselementets (3) første ende (31), hvori styreelementet (4) er fleksibelt mellem en lige tilstand, i hvilken styreelementet (4) strækker sig over en styrelængde (L) langs en lige linje (V) mellem trækelementet (2) og koblingselementets (3) anden ende (32), og en bøjet tilstand, i hvilken styreelementet (4) strækker sig langs en bøjet linje (W) mellem trækelementet (2) og koblingselementets (3) anden ende (32), hvori styreelementet (4) i den bøjede tilstand har en minimum bøjningsvinkel (H) mellem tilslutningsretningen (A) og modtageretningen (B) på mindst tyve grader pr. meter af styrelængden, fortrinsvis mindst tredive grader pr. meter af styrelængden, og mest foretrukket er mindst femogfyrre grader pr. meter af styrelængden.
2. Trækkonstruktion ifølge krav 1, hvori den bøjede linje har en minimumsradius i intervallet fra en til tre meter, og fortrinsvis i intervallet fra halvanden til to og en halv meter.
3. Trækkonstruktion ifølge krav 1, hvori styreelementet i den bøjede tilstand har en maksimal bøjningsvinkel på mindre end halvfjerds grader pr. meter af styrelængden, og fortrinsvis mindre end tres grader pr. meter af styrelængden.
4. Trækkonstruktion ifølge ethvert af de foregående krav, hvori styreelementet inden for det fleksible interval mellem den lige tilstand og den bøjede tilstand er i stand til at udøve et bøjningsmoment på koblingselementet i dennes åbne første ende på mindst tre kNm, og fortrinsvis på mindst fire kNm.
5. Trækkonstruktion ifølge ethvert af de foregående krav, hvori trækkonstruktionen yderligere omfatter et tilspændingselement, især en kæde, til tilspænding af styremidlet i en tilspændingsretning, fortrinsvis hvori tilspændingsretningen strækker sig parallelt,

radialt eller perifert i forhold til den rette linje, når styreelementet er i den lige tilstand.

6. Trækkonstruktion ifølge ethvert af kravene 1-4, hvori trækkonstruktionen er forsynet med en første tilspændingsbefæstelse ved eller i nærheden af trækelementet, og en anden tilspændingsbefæstelse ved eller i nærheden af koblingselementet, hvori styreelementet er forsynet med en hul kavitet, som strækker sig langs den rette linje i styreelementets lige tilstand fra den første tilspændingsbefæstelse til den anden tilspændingsbefæstelse til montering af et tilspændingselement mellem den første tilspændingsbefæstelse og den anden tilspændingsbefæstelse, fortrinsvis hvori positionen af en af den første tilspændingsbefæstelse og den anden tilspændingsbefæstelse kan justeres langs den lige linje i forhold til den anden af den første tilspændingsbefæstelse og den anden tilspændingsbefæstelse til justering af spændingen i tilspændingsbefæstelse.
7. Trækkonstruktion ifølge krav 6, hvori tilspændingselementet, den første tilspændingsbefæstelse og den anden tilspændingsbefæstelse har en belastningsgrænse på mindst fire kN, og fortrinsvis på mindst fem kN.
8. Trækkonstruktion ifølge ethvert af de foregående krav, hvori styreelementet omfatter et antal stive segmenter, som er forbundne med hinanden for at danne ledforbundne hvirvler, som strækker sig langs den rette linje i styreelementets lige tilstand, fortrinsvis hvori antallet af stive segmenter er indrettede til at ligge an mod hinanden i den bøjede tilstand for at begrænse hvirvlernes ledforbindelse til en maksimal bøjningsvinkel mellem tilslutningsretningen og modtagerretningen på mindre end halvfjers grader eller mindre end tres grader.
9. Trækkonstruktion ifølge krav 8, hvori styreelementet yderligere omfatter et fleksibelt segment mellem hvert par tilstødende stive segmenter til begrænsning af ledforbindelsen af nævnte par tilstødende stive segmenter, fortrinsvis hvori nævnte par tilstødende stive segmenter er koncentrisk forbundne med hinanden, hvori det fleksible segment er ringformet for at strække sig omkring den koncentriske forbindelse mellem nævnte par tilstødende stive segmenter.
10. Trækkonstruktion ifølge krav 9, hvori de fleksible segmenter består af eller omfatter et elastisk materiale, fortrinsvis et fjedrende elastomert materiale.
11. Trækkonstruktion ifølge ethvert af de foregående krav, hvori styreelementet tilspidser fra koblingselementet mod trækelementet, fortrinsvis hvori styreelementet tilspidser konisk fra

koblingselementet mod trækelementet.

12. Trækkonstruktion ifølge ethvert af de foregående krav, hvori det undersøiske kabel omfatter en eller flere isolerede, elektrisk ledende kerner og en cylindrisk eller i det væsentlige cylindrisk beskyttelseskappe, som omgiver nævnte ene eller flere kerner, hvori koblingselementet omfatter et cylindrisk koblingshylster til koncentrisk forbindelse med og rundtgående at kontakte nævnte beskyttelseskappe,
- fortrinsvis hvori det undersøiske kabel yderligere omfatter armering mellem beskyttelseskappen og den ene eller flere kerner, hvori armeringen omfatter et antal armeringstråde, og hvori mindst nogle af armeringstrådene er blottede med hensyn til beskyttelseskappen ved det undersøiske kables afisolerede ende, hvori koblingselementet omfatter et trådfikseringsværktøj til modtagelse og fiksering af i det mindste nogle af de blottede armeringstråde i modtageretningen i forhold til trådfikseringsværktøjet, hvori trådfikseringsværktøjet er operativt forbundet til koblingshylsteret til placering af koblingshylsteret i forhold til de fikserede armeringsstråde,
- mere foretrukket hvori koblingselementet yderligere omfatter et efterspændingselement til at efterspænde koblingshylsteret i en efterspændingsretning modsat modtageretningen mod og/eller over det undersøiske kables beskyttelseskappe,
- mere foretrukket hvori koblingselementet omfatter en gevindstang, som strækker sig fra trådfikseringsværktøjet i modtageretningen mod koblingselementets anden ende, hvori koblingselementet er forsynet med en endehætte, som kan forskydes over gevindstangen i efterspændingsretningen, hvori efterspændingselementet er en møtrik, som indgriber med gevindstangen i efterspændingsretningen fra en modsat side af endehætten i forhold til trådfikseringsværktøjet til tilspænding af endehætten i forhold til trådfikseringsværktøjet,
- mest foretrukket, hvori endehætten er integreret med eller fikseret i forhold til koblingshylsteret, eller hvori endehætten og koblingshylsteret er adskilte, og hvori endehætten er arrangeret til at ligge an mod koblingshylsteret i efterspændingsretningen.
13. Fremgangsmåde til trækning af et undersøisk kabel (9) ved anvendelse af trækkonstruktionen (1) ifølge ethvert af de foregående krav, hvori fremgangsmåden omfatter trinnene til:
- at afisolere en ende af det undersøiske kabel (9) for at opnå den afisolerede ende (99);

- at modtage det undersøiske kabels afisolerede ende (99) i modtageretningen (B) på linje med nævnte undersøiske kabels (9) længderetning (X) i koblingselementets (3) åbne første ende (31);
 - at forbinde trækkelementet (2) til et eksternt trækmiddel i tilslutningsretningen (A);
 - at udøve en trækraft på trækkelementet (2) ved anvendelse af de eksterne trækmidler til at trække det undersøiske kabel (9); og
 - at bøje styreelementet (4) fra den lige tilstand til den bøjede tilstand for at trække det undersøiske kabel (9) omkring en bøjning.
14. Fremgangsmåde ifølge krav 13, hvori fremgangsmåden yderligere omfatter trinnet til at bøje styreelementet i det fleksible interval mellem den lige tilstand og den bøjede tilstand og derved udøve et bøjningsmoment på koblingselementet ved dennes åbne første ende på mindst tre kNm, og fortrinsvis på mindst fire kNm.
15. Fremgangsmåde ifølge krav 13 eller 14, hvori det undersøiske kabel omfatter en eller flere isolerede, elektrisk ledende kerner og en cylindrisk eller i det væsentlige cylindrisk beskyttelseskappe, som omgiver nævnte ene eller flere kerner, hvori koblingselementet omfatter et cylindrisk koblingshylster, hvori fremgangsmåden yderligere omfatter trinnet til koncentrisk at forbinde koblingshylsteret til og i kontakt med beskyttelseskappen, fortrinsvis hvori armeringen omfatter et antal armeringstråde, og hvori mindst nogle af armeringstrådene er blottede med hensyn til beskyttelseskappen ved den afisolerede ende af det undersøiske kabel, hvori koblingselementet omfatter et trådfikseringsværktøj, hvori fremgangsmåden yderligere omfatter trinnene til at modtage og fikserer mindst nogle af de blottede tråde i modtageretningen i trådfikseringsværktøjet og operativt at forbinde trådfikseringsværktøjet til koblingshylsteret til placering af koblingshylsteret i forhold til de fikserede armeringstråde, mere foretrukket hvori fremgangsmåden yderligere omfatter trinnet til at efterspænde koblingshylsteret i en efterspændingsretning modsat modtageretningen mod og/eller over det undersøiske kabels beskyttelseskappe.
16. Fremgangsmåde ifølge ethvert af kravene 13-15, hvori fremgangsmåden yderligere omfatter trinnet til at tilvejebringe en eller flere første vandtætte forseglinger mellem koblingselementet og det undersøiske kabels afisolerede ende for at forsegle nævnte afisolerede ende mod vandindtrængning, eller hvori fremgangsmåde yderligere omfatter trinnet til at tilvejebringe en eller flere anden vandtætte forseglinger mellem koblingselementet og styreelementet for at forsegle koblingselementet mod vandindtrængning.

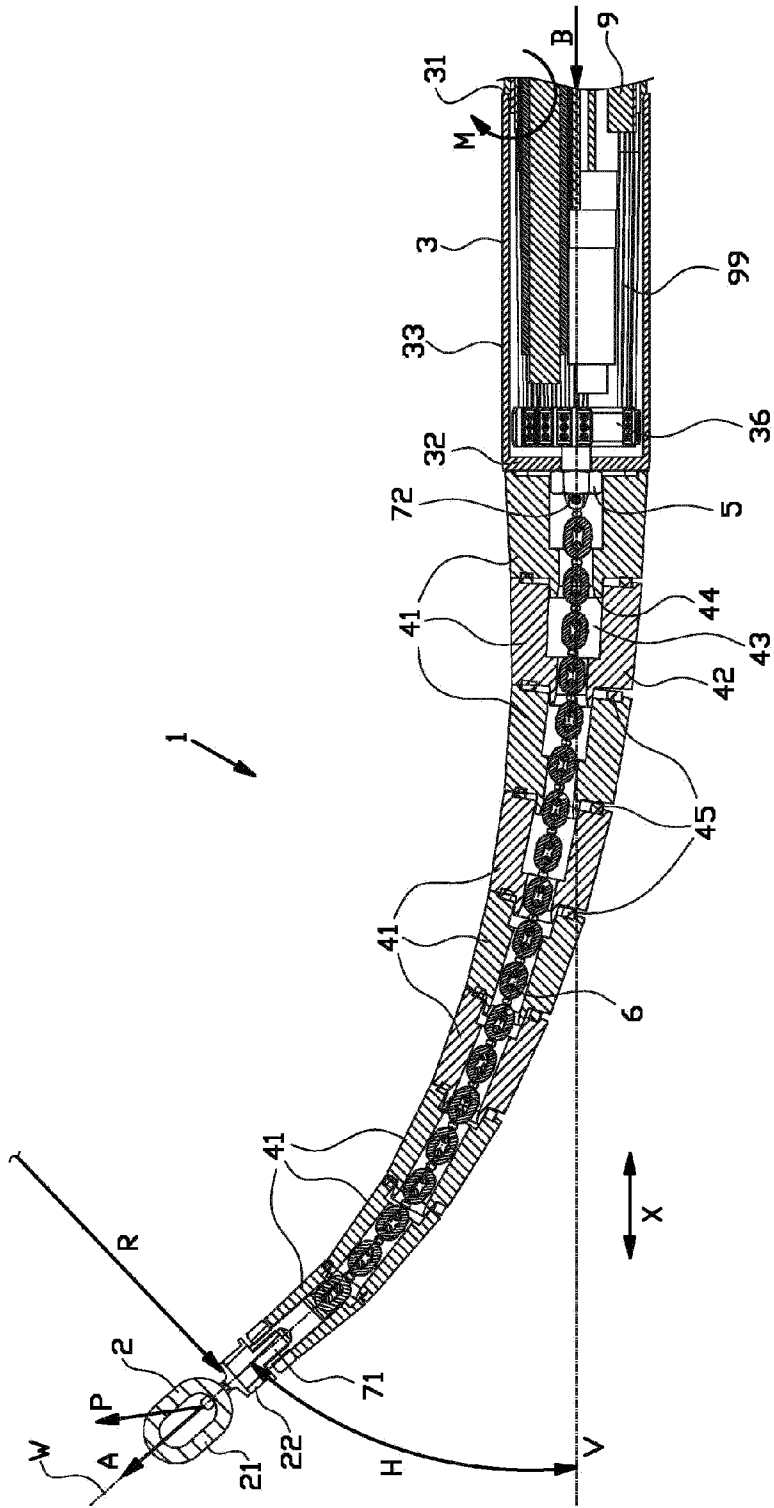

FIG. 3

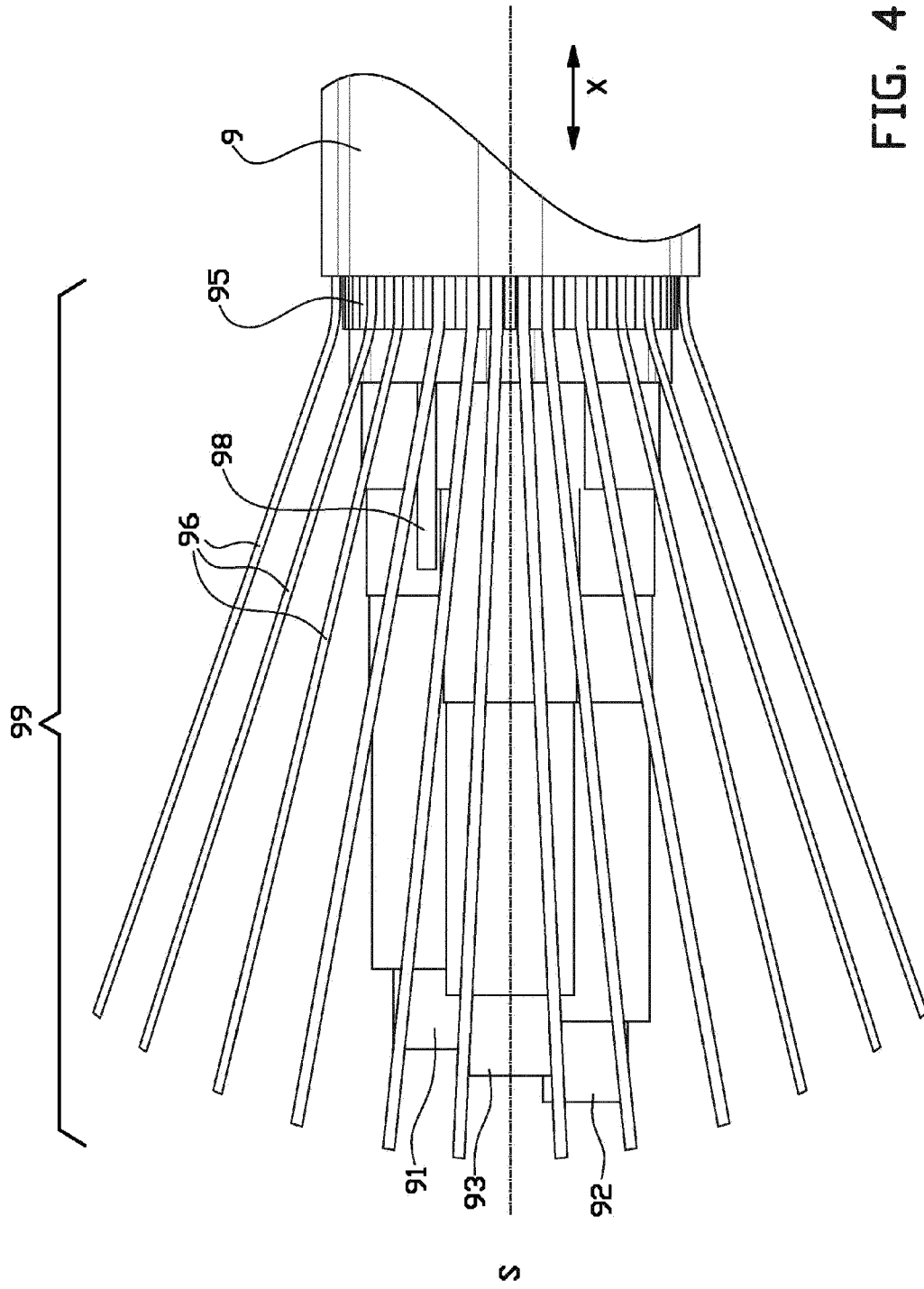

FIG. 4

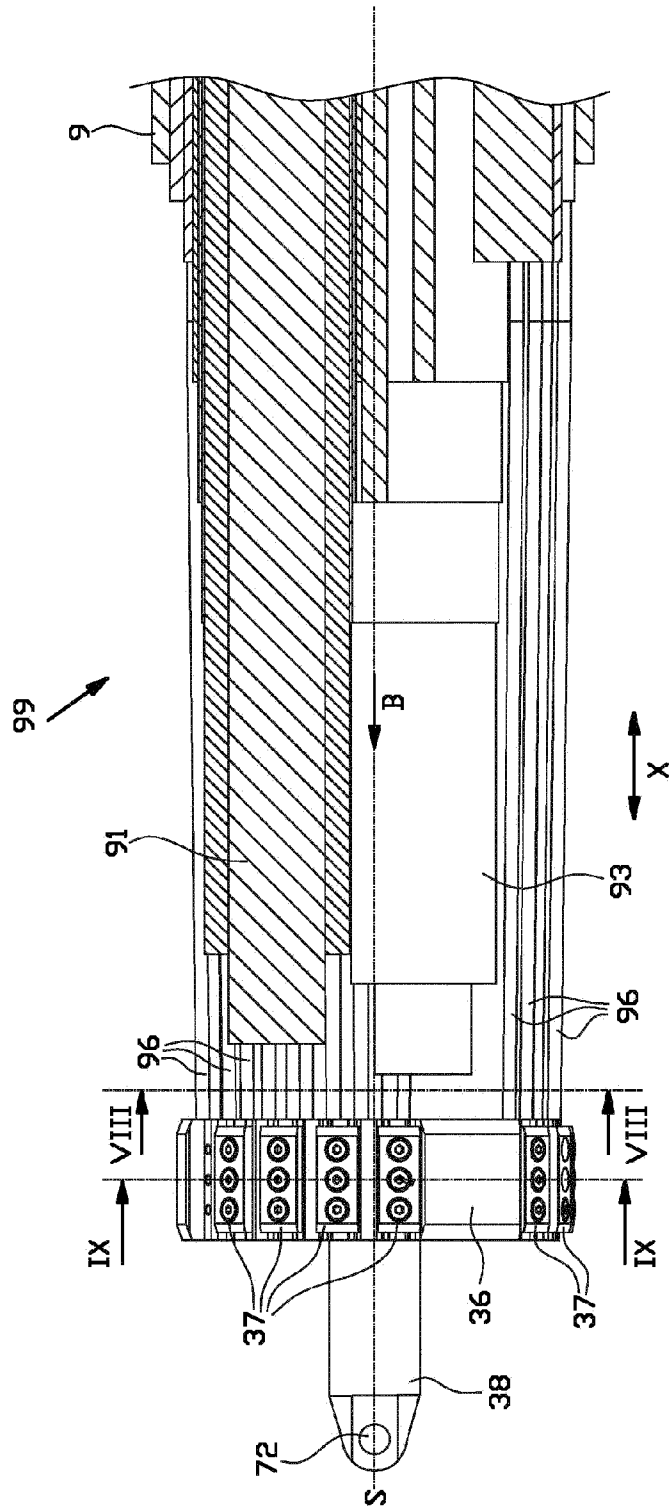

FIG. 5

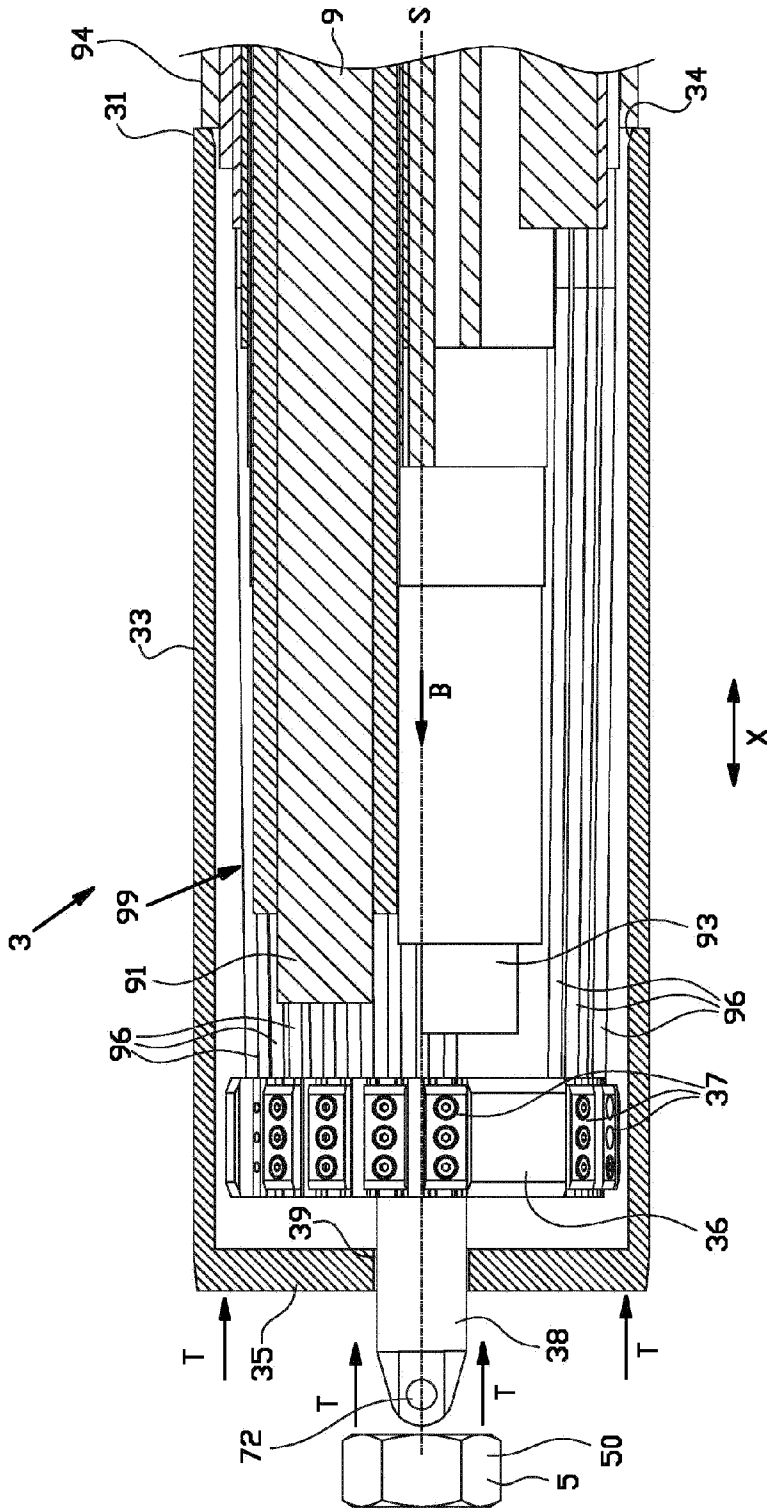

FIG. 6

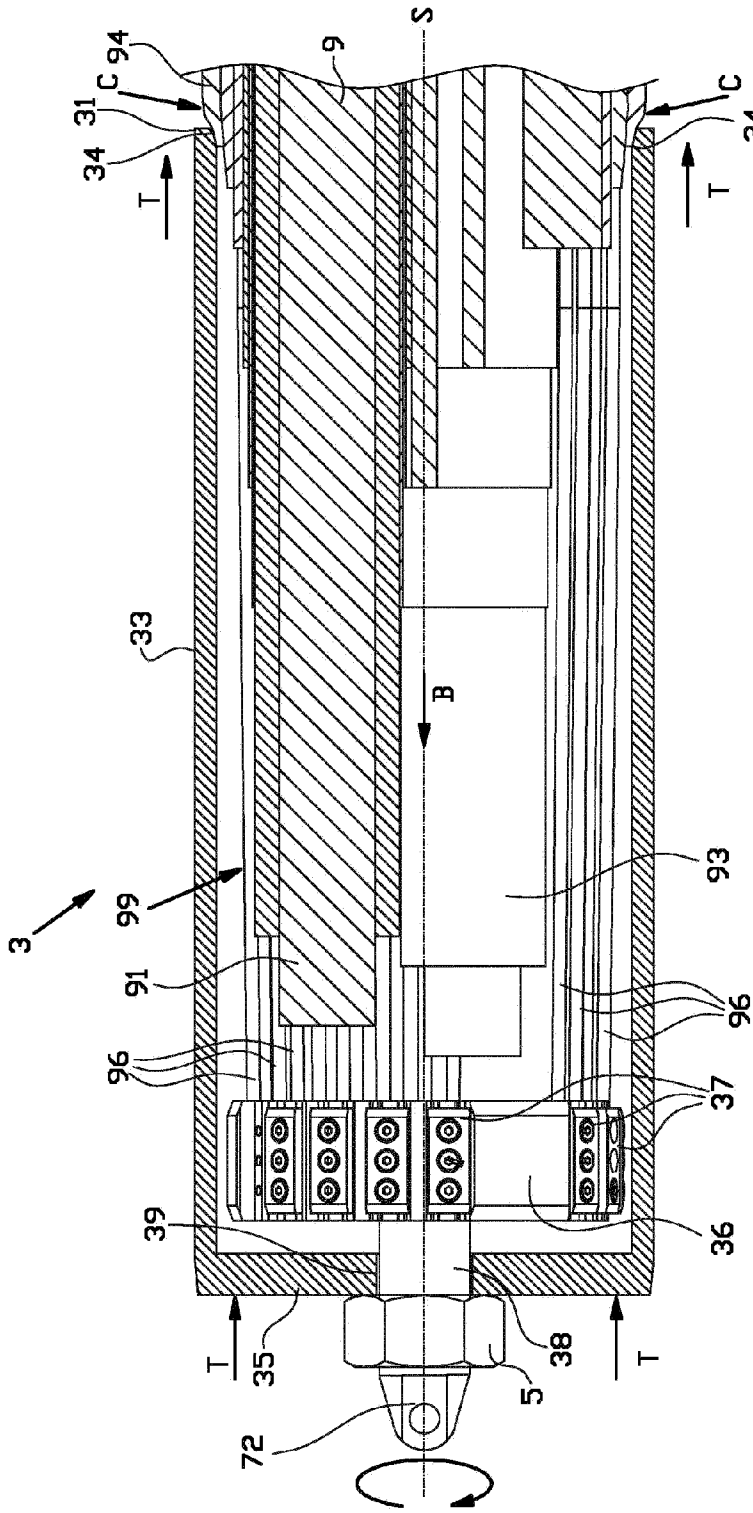

FIG. 7

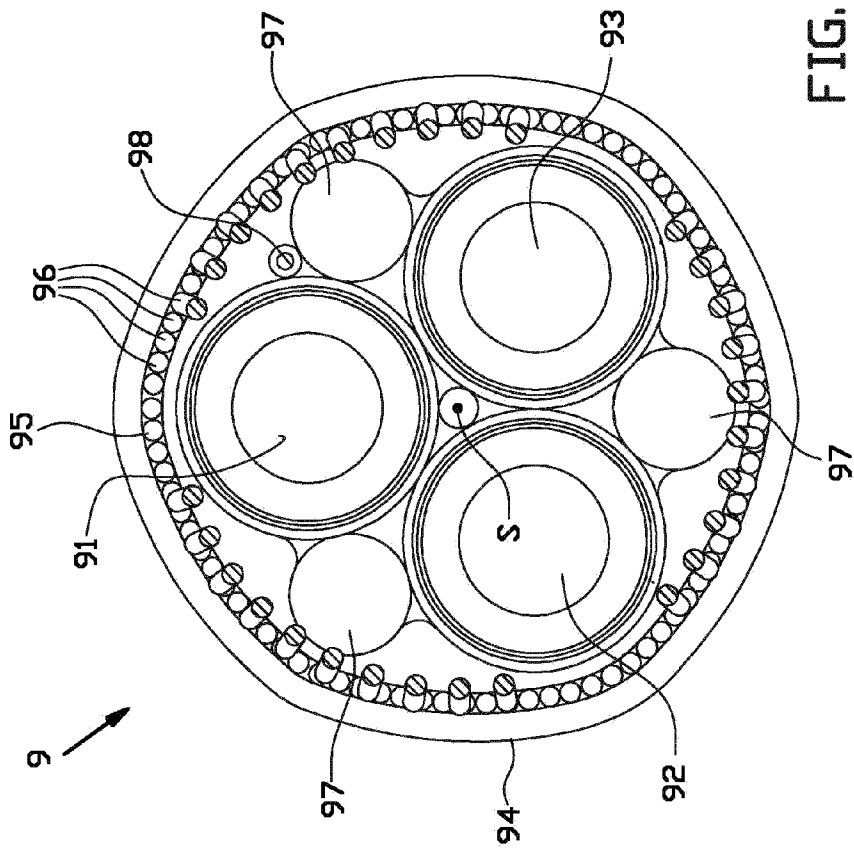

FIG. 8

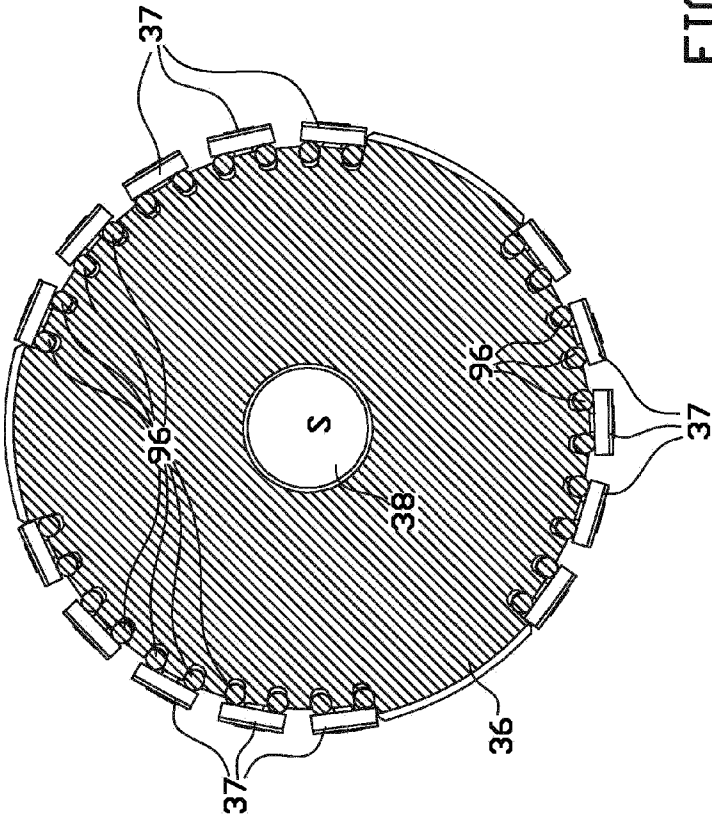

FIG. 9

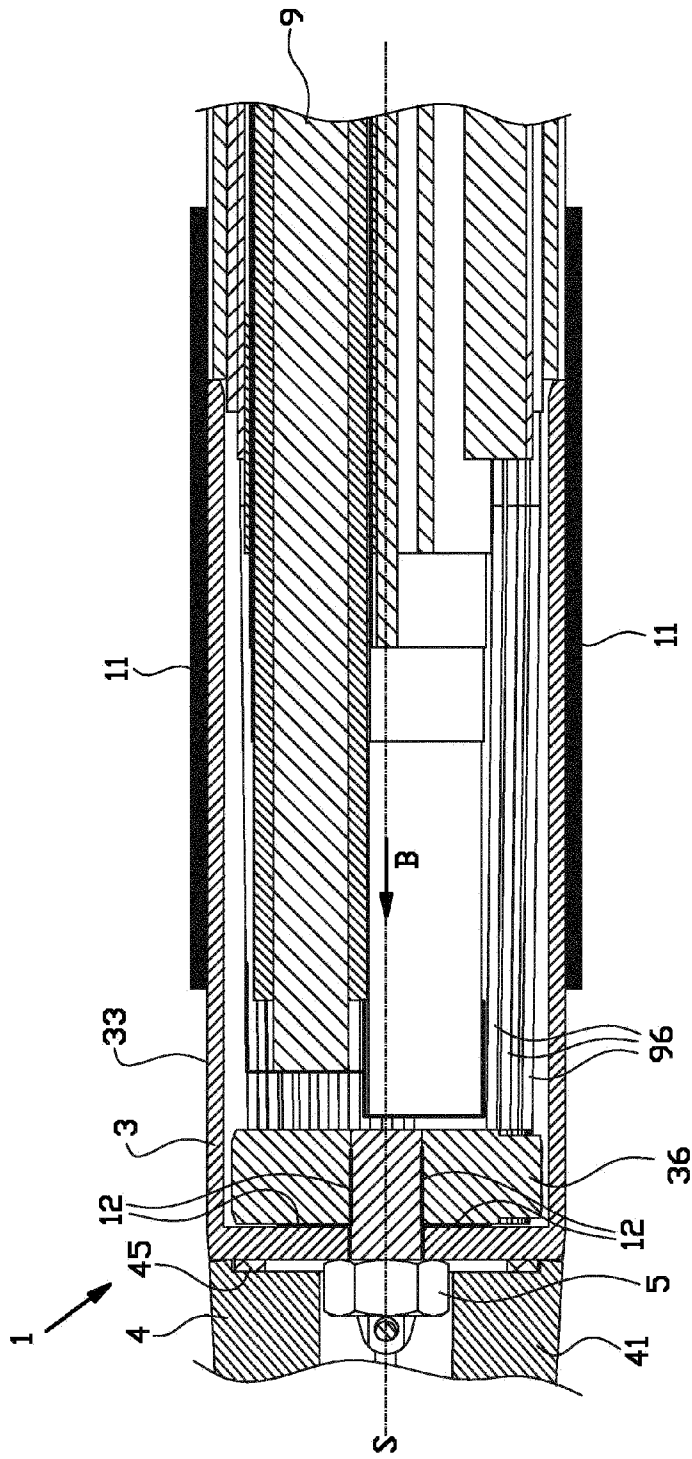

FIG. 10

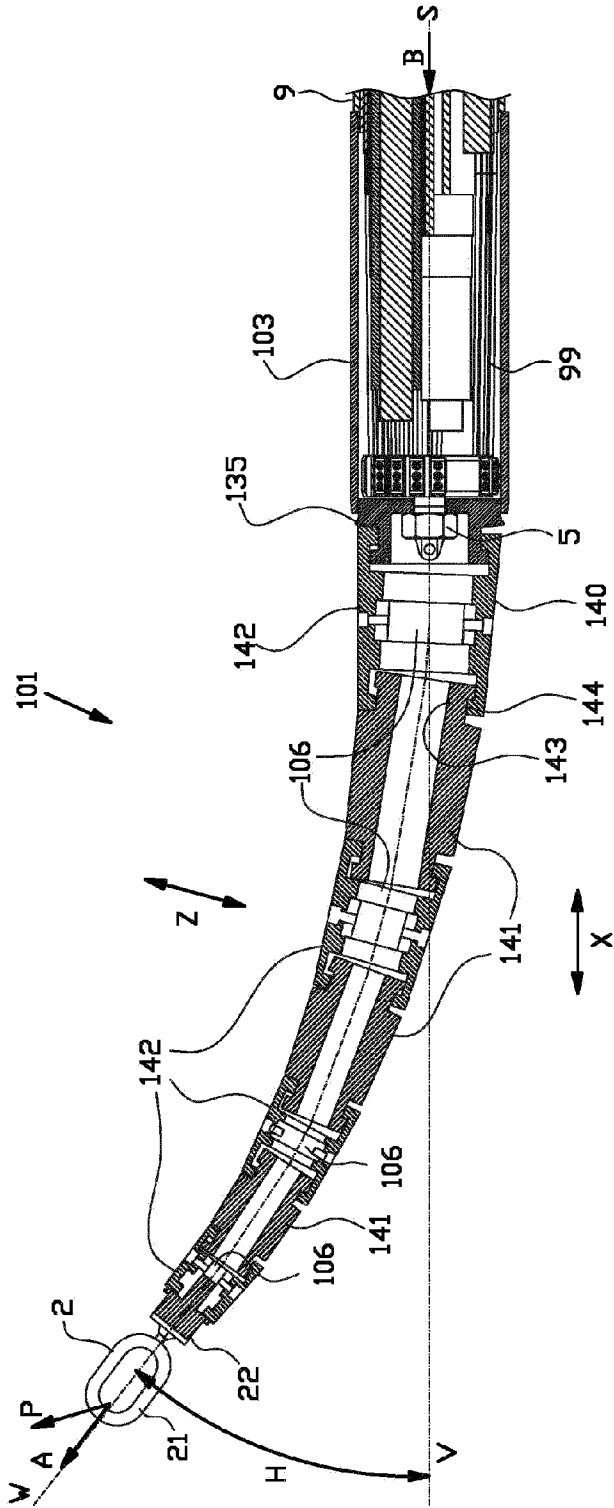

FIG. 11

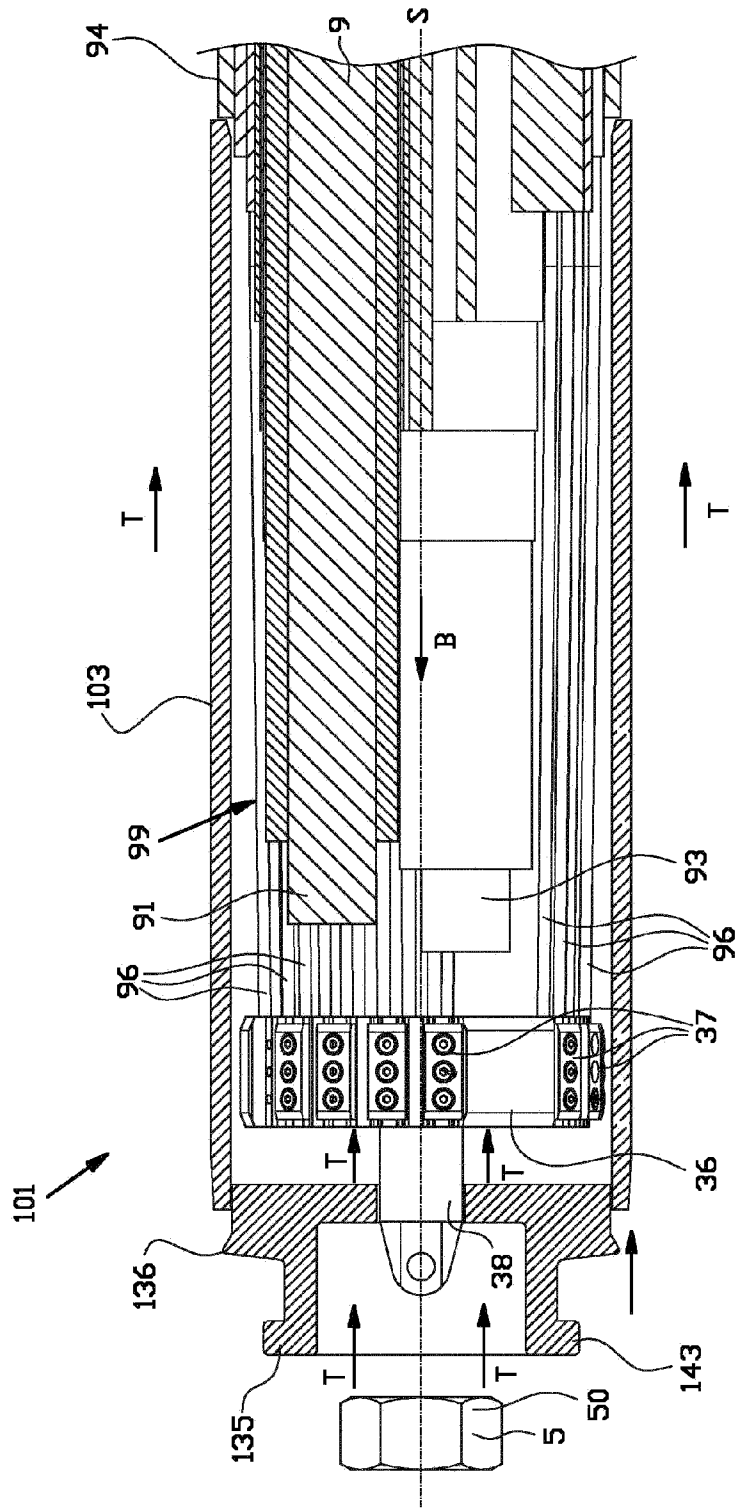

FIG. 12

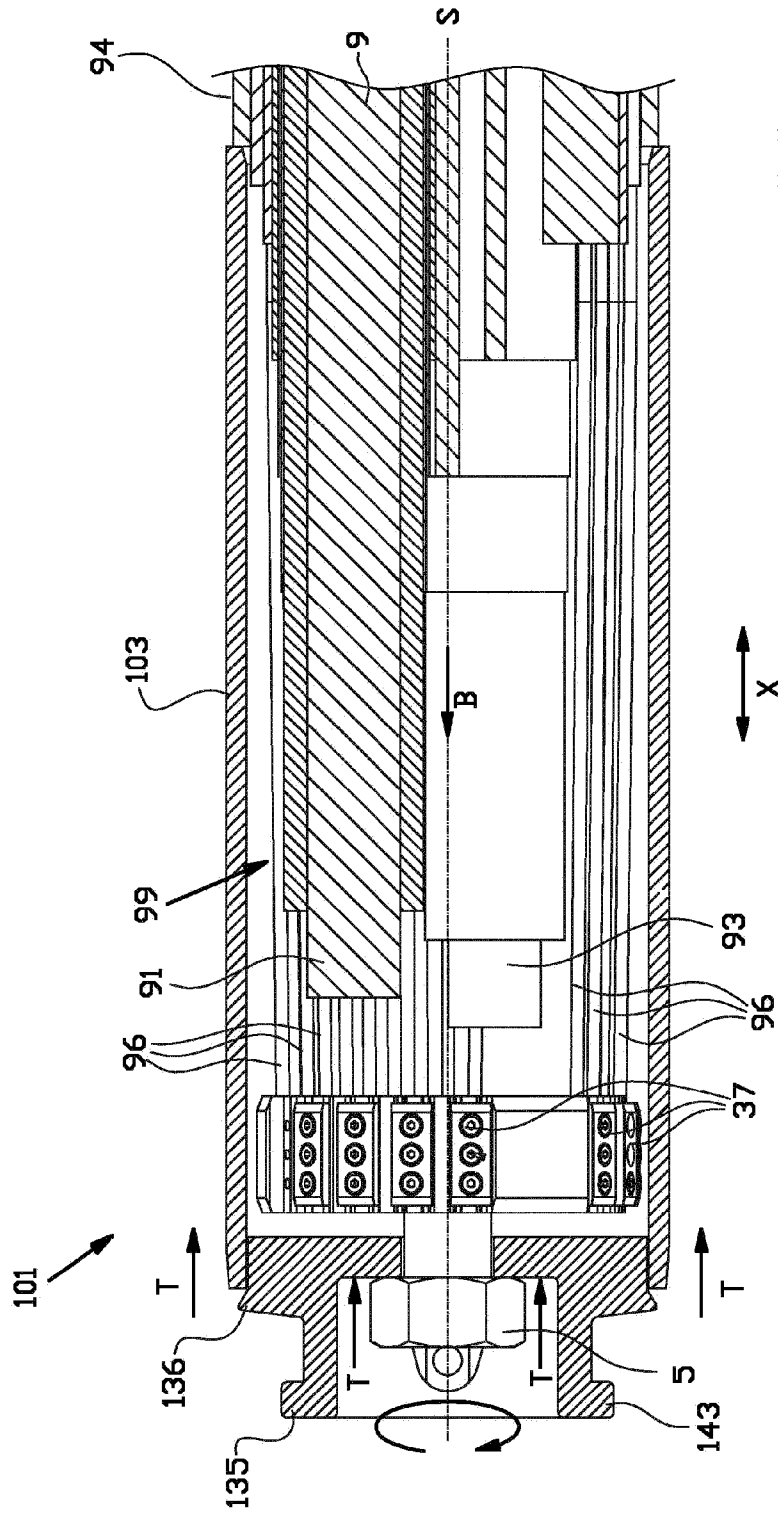

FIG. 13

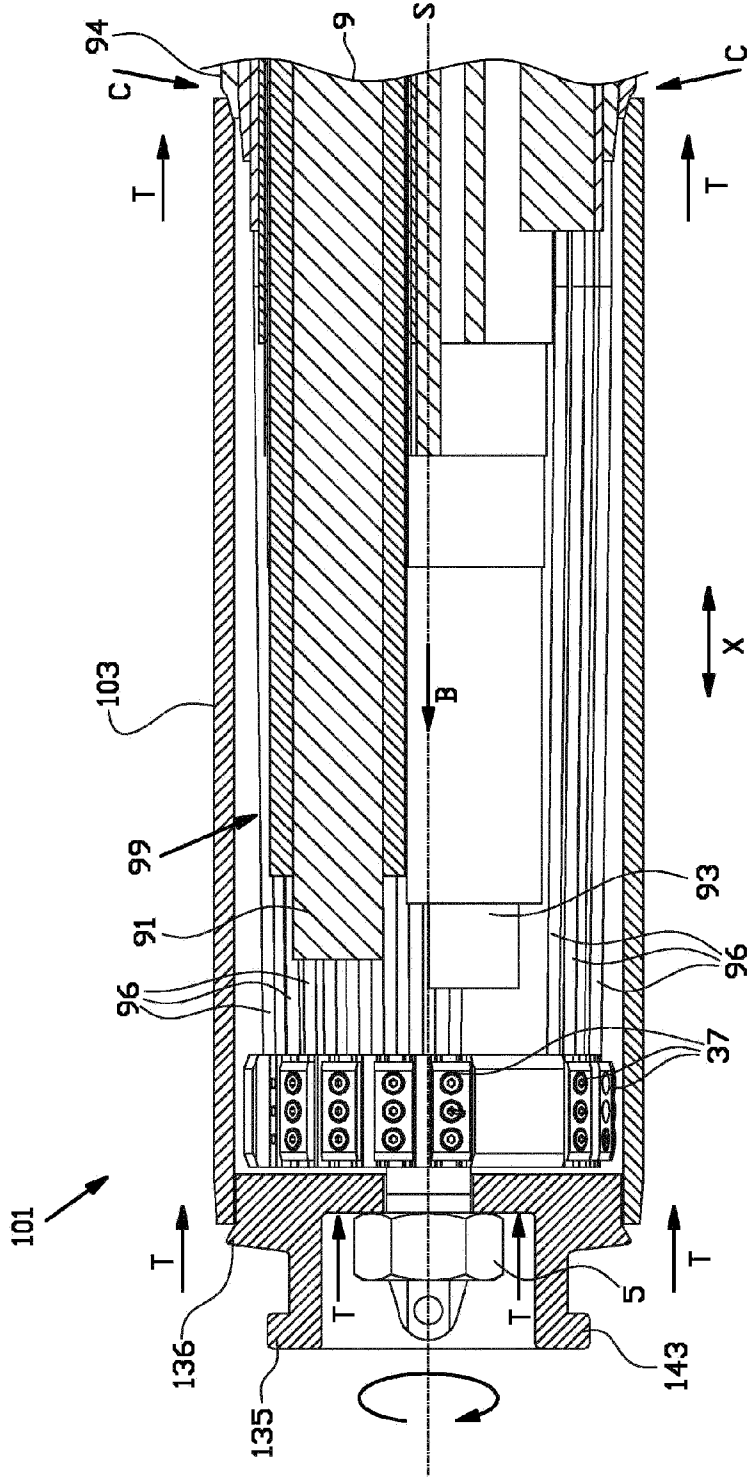

FIG. 14