

F. LA POINT.  
TABLE CLAMP.

APPLICATION FILED MAR. 25, 1922.

1,425,868.

Patented Aug. 15, 1922.

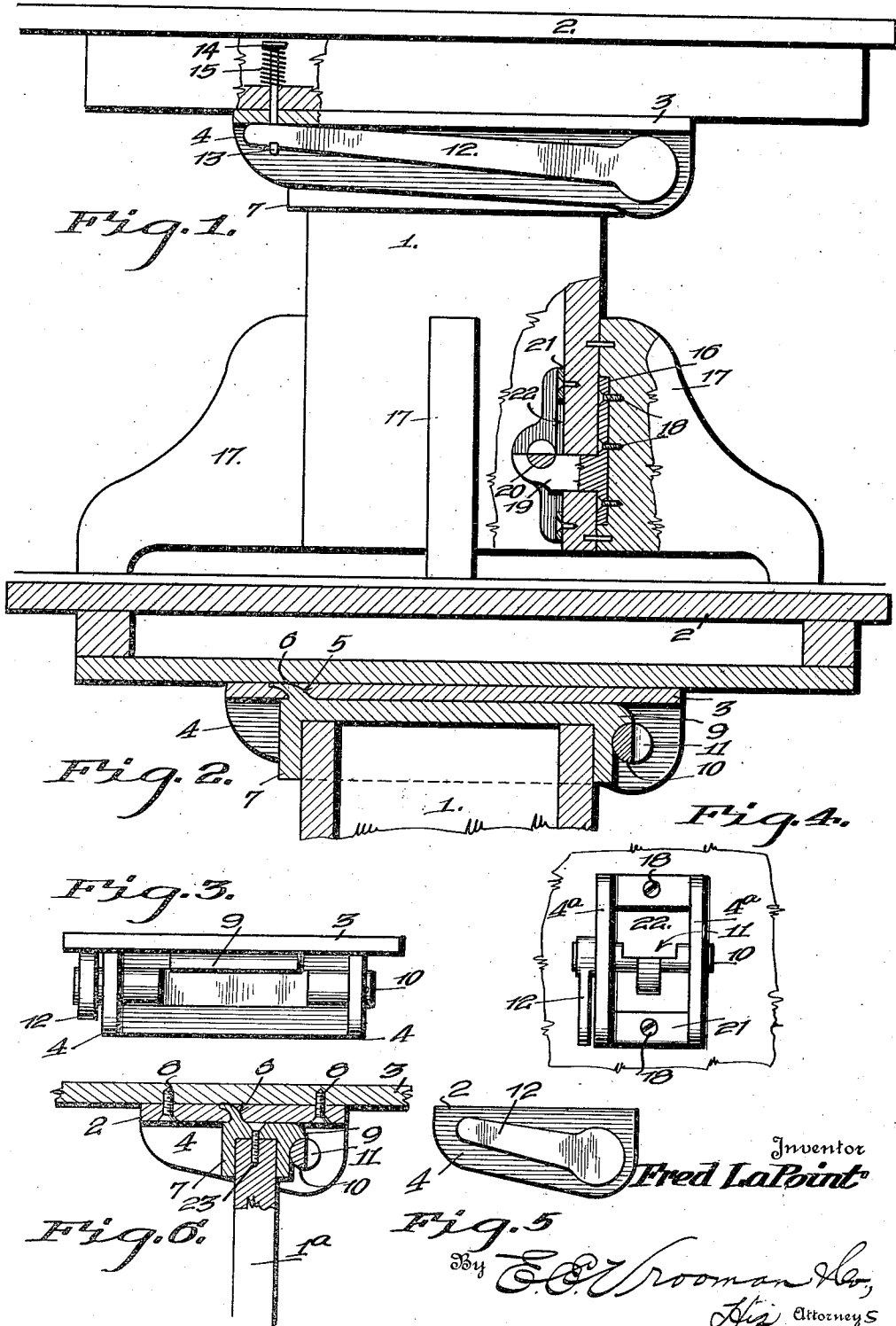

# UNITED STATES PATENT OFFICE.

FRED LA POINT, OF WHEELING, WEST VIRGINIA.

## TABLE CLAMP.

1,425,868.

Specification of Letters Patent. Patented Aug. 15, 1922.

Application filed March 25, 1922. Serial No. 546,703.

To all whom it may concern:

Be it known that I, FRED LA POINT, a citizen of the United States, residing at Wheeling, in the county of Ohio and State of West Virginia, have invented certain new and useful Improvements in Table Clamps, of which the following is a specification, reference being had therein to the accompanying drawings.

10 This invention relates to a table clamp, and the object of the invention is the construction of a clamping device which can be used to secure the top of a table to a pedestal or a leg to a pedestal.

15 Another object of the invention is the construction of a simple and efficient device which will enable the operator to quickly attach or detach a table top or a leg to a pedestal.

20 With these and other objects in view, my invention comprises certain novel combinations, constructions and arrangements of parts as will be hereinafter described, illustrated in the accompanying drawings, and more particularly pointed out in the ap-  
25 pended claims.

In the drawings:

30 Figure 1 is a view in side elevation, partly in section, showing a device constructed in accordance with the present invention.

Figure 2 is a fragmentary, sectional view of the top of a table.

35 Figure 3 is an end view of the clamping device used for securing the top of a table upon a pedestal.

Figure 4 is a view, in elevation, of the rear portion of a clamping device used for securing a table leg to a pedestal.

40 Figure 5 is a view, in side elevation, of the clamping device shown in Figure 3.

Figure 6 is a fragmentary, vertical, sectional view of a table, showing a modified form of the clamping device for securing the top of a table on a pedestal.

45 Referring to the drawings by numerals, 1 designates the pedestal, and 2 is the table top; the pedestal is preferably hollow, as shown in Fig. 2.

50 My clamping device comprises a supporting means consisting of a flat table plate 3 which is provided with a pair of depending flanges 4-4; these flanges 4 are arranged in parallel relation. In the plate 3 is an elongated slot 5 for receiving the curved, upwardly-extending spur 6 that is  
55 integral with the cap 7. Cap 7 fits over

the top of the pedestal 1 and is secured to the pedestal by any ordinary fastening means, such as screws (not shown). The table plate 3 is secured to the top 2 (of any ordinary structure) by means of screws  
60 8, Fig. 6.

The cap 7 is provided on one side with a horizontally-extending lug 9. Journalled in the ends of the flanges 4 is shaft 10; this shaft 10 is provided with a cut-out portion 11 which is adapted to permit of the passage of the lug 9 by shaft 10 when the table top 2 is being lifted off the cap 7. A lever arm 12 is fastened to one end of shaft 10, and the other end of the lever arm is adapted to be held in the outer end of the hook bolt 13, Fig. 1. The hook bolt 13 is provided on its inner end with a cap 14, and pressing against the cap 14 is coil  
70 spring 15 which normally holds the lever against table plate 3 but the operator can pull down on the lever and unseat the same from the hook bolt 13 and then swing the lever downwardly and outwardly to allow  
75 the cut-out portion 11 to register with the lug 9, whereby the lug 9 can pass by the shaft 10, and the table top can be lifted off the pedestal.

80 In Figs. 1 and 4 I have shown a leg clamping device embodying the same principle, to wit: the leg plate 16 is counter-sunk in each leg 17, and this leg plate is fastened to the legs by screws 18. Extending from the plate 16, in a horizontal position, is the lug 19 that is provided with a shaft-receiving socket 20. The plate 21 is provided with a pair of parallel flanges 4<sup>a</sup>, and journalled upon these flanges is a shaft 10 provided with the cut-out portion 11. On one end of shaft 10 is lever arm 12. When the fastening device is in the position shown in Fig. 1, with the shaft in the shaft-receiving socket 20, the leg is locked against the pedestal 1 but by rotating the shaft by means of lever 12, the cut-out portion 11 can be placed in position for allowing the lug 19 to pass by the shaft, thereby permitting the removal of the leg from the pedestal. Of course, it is to be understood that plate 21 is provided with an elongated large aperture 22 which allowed the lug 19 to extend through the plate, Fig. 1.

85 In Fig. 6 I have shown a slight modification of the device, especially adapted to be used on a solid pedestal 1<sup>a</sup>. In this in-  
90  
95  
100  
105  
110

stance, the screw 23 extends through the top of the cap into the top of the pedestal 1<sup>a</sup>, for securing the cap thereto. By reason of my clamping device, a table may be quickly taken apart or put together, which enables the operator to move the table from one room to another, through a narrow door or opening. Further, by reason of the parts of the table being so simply attached, the parts of the table can be quickly separated for packing and shipment, thereby saving time and expense.

While I have described the preferred embodiments of my invention, and have illustrated the same in the accompanying drawings, certain minor changes or alterations may appear to one skilled in the art to which this invention relates, during the extensive manufacture of the same and I, therefore, reserve the right to make such alterations or changes as shall fairly fall within the scope of the appended claims.

What I claim is:

1. In a device of the class described, the combination of a table plate provided between two of its side edges with a pair of parallel flanges, said plate provided between said flanges with a spur-receiving slot, a pedestal cap provided on its top with a spur adapted to be seated in said spur-receiving slot and on one side with an outwardly-extending lug, a shaft journaled upon said flanges near one end, said shaft provided with a cut-out portion adapted to permit the passage of said lug on said pedestal cap, a lever arm on said shaft and adapted to rotate the same for causing the shaft to engage the lug for holding the table plate against the pedestal cap, substantially as shown and described.

2. In a device of the class described, the combination of a supporting means, a shaft rotatably mounted upon said supporting means, said shaft having a cut-out portion, means for rotating said shaft, an engaging

member having a spur and a lug, said supporting means having a slot, said spur being adapted to fit within said slot and said lug being adapted to be engaged by said shaft, as and for the purposes set forth.

3. In a device of the class described, the combination of a supporting means, a shaft rotatably mounted upon said supporting means, said shaft having a cut-out portion, a lever arm connected to one end of said shaft, a resiliently actuated hook bill releasably engaging said lever arm for holding the same in a set position, and an engaging member having a lug adapted to releasably engage said shaft, as and for the purposes set forth.

4. In a device of the class described, the combination of a table plate, said table plate having a slot, a shaft having a cut-out portion, means rotatably supporting said shaft upon said table plate, means for rotating said shaft, a cap having a spur removably fitting in said slot, and a lug on said cap engaging said shaft, as and for the purposes set forth.

5. In a device of the class described, the combination of a table plate, a shaft having a cut-out portion, means rotatably supporting said shaft upon said table plate, means for rotating said shaft, a cap having a lug, said cap and said plate having a disengageable interlocking means and said lug engaging said shaft, as and for the purposes set forth.

6. In a device of the class described, the combination of a table plate having depending parallel flanges, a shaft rotatably mounted upon said flanges and having a cut-out portion, a cap having a lug, said cap and said plate having a disengageable interlocking means and said lug engaging said shaft, as and for the purposes set forth.

In testimony whereof I hereunto affix my signature.

FRED LA POINT.