

(19) **DANMARK**

(10) **DK/EP 3448031 T3**



(12) **Oversættelse af
europæisk patentskrift**

Patent- og
Varemærkestyrelsen

-
- (51) Int.Cl.: **H 04 N 19/46 (2014.01)** **H 04 N 19/463 (2014.01)** **H 04 N 19/51 (2014.01)**
H 04 N 19/513 (2014.01) **H 04 N 19/91 (2014.01)**
- (45) Oversættelsen bekendtgjort den: **2021-02-01**
- (80) Dato for Den Europæiske Patentmyndigheds bekendtgørelse om meddelelse af patentet: **2020-12-23**
- (86) Europæisk ansøgning nr.: **18193270.8**
- (86) Europæisk indleveringsdag: **2009-06-18**
- (87) Den europæiske ansøgnings publiceringsdag: **2019-02-27**
- (62) Stamansøgningsnr: **14158493.8**
- (84) Designerede stater: **AT BE BG CH CY CZ DE DK EE ES FI FR GB GR HR HU IE IS IT LI LT LU LV MC MK MT NL NO PL PT RO SE SI SK TR**
- (73) Patenthaver: **Kabushiki Kaisha Toshiba, 1-1, Shibaura 1-chome, Minato-ku, Tokyo 105-0023, Japan**
- (72) Opfinder: **ASAKA, Saori, c/o IP Div. Toshiba Corp. (K.K. TOSHIBA), 1-1, Shibaura 1-chome, Minato-ku, Tokyo, 105-0023, Japan**
CHUJOH, Takeshi, c/o IP Div. Toshiba Corp. (K.K. TOSHIBA), 1-1, Shibaura 1-chome, Minato-ku, Tokyo, 105-0023, Japan
TANIZAWA, Akiyuki, c/o IP Div. Toshiba Corp. (K.K. TOSHIBA), 1-1, Shibaura 1-chome, Minato-ku, Tokyo, 105-0023, Japan
YASUDA, Goki, c/o IP Div. Toshiba Corp. (K.K. TOSHIBA), 1-1, Shibaura 1-chome, Minato-ku, Tokyo, 105-0023, Japan
WADA, Naofumi, c/o IP Div. Toshiba Corp. (K.K. TOSHIBA), 1-1, Shibaura 1-chome, Minato-ku, Tokyo, 105-0023, Japan
WATANABE, Takashi, c/o IP Div. Toshiba Corp. (K.K. TOSHIBA), 1-1, Shibaura 1-chome, Minato-ku, Tokyo, 105-0023, Japan
- (74) Fuldmægtig i Danmark: **Marks & Clerk (Luxembourg) LLP, 44 rue de la Vallée, B.P. 1775, L-1017 Luxembourg, Luxembourg**
- (54) Benævnelse: **VIDEOAFKODNINGSANORDNING OG VIDEOAFKODNINGSFREMGANGSMÅDE**
- (56) Fremdragne publikationer:
WO-A2-2008/086316
JUNG ORANGE-FRANCE TELECOM R&D (FRANCE) J ET AL: "RD-optimized competition scheme for efficient motion prediction", VISUAL COMMUNICATIONS AND IMAGE PROCESSING; 30-1-2007 - 1-2-2007; SAN JOSE,, 30 January 2007 (2007-01-30), XP030081116,
SUNG DEUK KIM ET AL: "An Efficient Motion Vector Coding Scheme Based on Minimum Bitrate Prediction", IEEE TRANSACTIONS ON IMAGE PROCESSING, IEEE SERVICE CENTER, PISCATAWAY, NJ, US, vol. 8, no. 8, 1 August 1999 (1999-08-01), XP011026355, ISSN: 1057-7149
ALEXIS M TOURAPIS ET AL: "Direct macroblock coding for predictive (P) pictures in the H.264 standard", VISUAL COMMUNICATIONS AND IMAGE PROCESSING; 20-1-2004 - 20-1-2004; SAN JOSE,, 20 January 2004 (2004-01-20), XP030081301,

Fortsættes ...

DESCRIPTION

Technical Field

[0001] The present invention relates to a video decoding apparatus which derives a motion vector from an encoded and decoded image and perform a motion compensated prediction.

Background Art

[0002] There is a motion compensated prediction as one of techniques used for encoding a video image.

[0003] In the motion compensated prediction, a video encoding apparatus acquires a motion vector using a to-be-encoded image to be newly encoded and a local decoded image already generated and generates a prediction image by carrying out motion compensation using this motion vector.

[0004] As one of methods for acquiring a motion vector in the motion compensated prediction, there is a direct mode for generating a prediction image using a motion vector of a to-be-encoded block derived from the motion vector of an encoded block (refer to Japanese Patent No. 4020789 and U.S. Patent No. 7233621). Because the motion vector is not encoded in the direct mode, the number of encoded bits of the motion vector information can be reduced. The direct mode is employed in H.264/AVC.

[0005] Jung et al "RD-optimized competition scheme for efficient motion prediction", Visual Communications and Image Processing; 30-1-2007-1-2-2007: San Jose, 30 January 2007 relates to a competition based scheme for the prediction of motion vectors.

[0006] WO 2008/086316 relates to a variable length coding technique for coded block patterns.

Disclosure of Invention

[0007] In the direct mode, a motion vector is generated by a method for calculating a motion vector from a median value of the motion vector of an encoded block adjacent to a to-be-encoded block in generating the motion vector of the to-be-encoded block by prediction. Therefore, degrees of freedom for calculating the motion vector calculation are low. In addition, when a method for calculating a motion vector by selecting one from a plurality of encoded blocks is used for improving the degrees of freedom, the position of the block must be always sent as motion vector selection information in order to indicate the selected encoded block. For

this reason, the number of encoded bits may be increased.

[0008] It is an object of the present invention to provide a video decoding apparatus which reduces additional information of motion vector selection information while improving the degrees of freedom for calculating the motion vector by selecting one from encoded blocks.

[0009] An aspect of the present invention provides a video decoding apparatus as recited in claim 1. In a further aspect, a video decoding method is provided as recited in claim 2. In a yet further aspect, a computer program is provided as recited in claim 3.

Brief Description of Drawings

[0010]

FIG. 1 is a block diagram of a video encoding apparatus.

FIG. 2 is a flowchart representing a processing procedure of the video encoding apparatus.

FIG. 3 is a flowchart representing a processing procedure of an acquisition /selection module.

FIG. 4A is a diagram for describing a discrimination method based on a block size.

FIG. 4B is a diagram for describing a discrimination method based on a block size.

FIG. 4C is a diagram for describing a discrimination method based on a block size.

FIG. 5 is a diagram for describing a discrimination method by a unidirectional or a bidirectional.

FIG. 6 is a flowchart representing a processing procedure of a selection information encoder.

FIG. 7 shows an example of an index of selection information.

FIG. 8 shows an example of a code table of selection information.

FIG. 9 is a schematic view of a syntax structure.

FIG. 10 shows a data structure of a macroblock layer.

FIG. 11 shows a block diagram of a video decoding apparatus according to an embodiment of the present invention.

FIG. 12 shows a flowchart representing a processing procedure of the video decoding apparatus.

Mode for Carrying Out the Invention

[0011] There will now be explained embodiments of the present invention referring to drawings.

[0012] A video encoding apparatus is described with reference to FIG. 1 hereinafter. A subtracter 101 calculates a difference between an input video signal 11 and a predictive coded video signal 15, and output a prediction error signal 12. The output terminal of the subtracter 101 is connected to a variable length encoder 111 through an orthogonal transformer 102 and a quantizer 103. The orthogonal transformer 102 orthogonal-transforms a prediction error signal 12 from the subtracter 101, and the quantizer 103 quantizes an orthogonal transformation coefficient and outputs quantization orthogonal transformation coefficient information 13. The variable length encoder 111 performs variable length encoding on the quantization orthogonal transformation coefficient information 13 from the quantizer 103.

[0013] The output terminal of the quantizer 103 is connected to an adder 106 through a dequantizer 104 and an inverse orthogonal transformer 105. The dequantizer 104 dequantizes the quantized orthogonal transformation coefficient information 13, and converts it in an orthogonal transformation coefficient. The inverse orthogonal transformer 105 converts the orthogonal transformation coefficient to a prediction error signal. The adder 106 adds the prediction error signal of the inverse orthogonal transformer 105 and the predictive coded video signal 15 to generate a local decoded image signal 14. The output terminal of the adder 106 is connected to a motion compensated prediction module 108 through a frame memory 107.

[0014] The frame memory 107 accumulates a local decoded image signal 14. A setting module 114 sets a motion compensated prediction mode (a prediction mode) of a to-be-encoded block. The prediction mode includes a unidirectional prediction using a single reference picture and a bidirectional prediction using two reference pictures. The unidirectional prediction includes L0 prediction and L1 prediction of AVC. A motion compensated prediction module 108 comprises a prediction module 109 and an acquisition/selection module 110.

[0015] The acquisition/selection module 110 acquires available blocks having motion vectors and the number of the available blocks from encoded blocks adjacent to the to-be-encoded block, and selects a selection block from the available blocks. The motion compensated prediction module 108 performs a prediction using a local decoded image signal 14 stored in the frame memory 107 as a reference image and generates a predictive coded video signal 15. The acquisition/selection module 110 selects one block (a selection block) from the adjacent blocks adjacent to the to-be-encoded block. For example, the block having an appropriate motion vector among the adjacent blocks is selected as the selection block. The acquisition/selection module 110 selects the motion vector of the selection block as a motion vector 16 to be used for the motion compensated prediction, and sends it to the prediction module 109. In addition, the acquisition/selection module 110 generates selection information 17 of the selection block and sends it to the variable length encoder 111.

[0016] The variable length encoder 111 has a selection information encoder 112. The selection information encoder 112 subjects the selection information 17 to variable length encoding while switching a code table so as to have therein the same number of entries as the available blocks of encoded blocks. The available block is a block having a motion vector among encoded blocks adjacent to the to-be-encoded block. A multiplexer 113 multiplexes quantized orthogonal transformation coefficient information and selection information and outputs encoded data.

[0017] The action of the video encoding apparatus of the above configuration will be described referring to the flowchart of FIG. 2.

[0018] At first a prediction error signal 12 is generated (S11). In generation of this prediction error signal 12, a motion vector is selected, and a prediction image is generated using the selected motion vector. The subtracter 101 calculates a difference between the signal of the prediction image, that is, the prediction image signal 15 and the input video signal 11 to generate the prediction error signal 12.

[0019] The orthogonal transformer 102 orthogonal-transforms the prediction error signal 12 to generate an orthogonal transformed coefficient (S12). The quantizer 103 quantizes the orthogonal transformed coefficient (S13). The dequantizer 104 dequantizes the quantized orthogonal transformed coefficient information (S14), and then subjects it to inverse orthogonal transform to provide a reproduced prediction error signal (S15). The adder 106 adds the reproduced prediction error signal and the predictive coded video signal 15 to generate a local decoded image signal 14 (S16). The local decoded image signal 14 is stored in the frame memory 107 (as a reference picture) (S17), and the local decoded image signal read from the frame memory 107 is inputted to the motion compensated prediction module 108.

[0020] The prediction module 109 of the motion compensated prediction module 108 subjects the local decoded image signal (reference image) to motion compensated prediction using the motion vector 16 to generate the predictive coded video signal 15. The predictive coded video signal 15 is sent to the subtracter 101 to calculate a difference with respect to the input video signal 11, and further is sent to the adder 106 to generate the local decoded image signal 14.

[0021] The acquisition/selection module 110 selects a selection block from adjacent blocks, generates selection information 17 and sends a motion vector 16 of the selection block to the prediction module 109 which performs the motion compensated prediction using the motion vector of the selection block. The selection information 17 is sent to the selection information encoder 112. When the selection block is selected from the adjacent blocks, the appropriate motion vector allowing the amount of encoded bits to be decreased is selected.

[0022] The orthogonal transformation coefficient information 13 quantized with the quantizer 103 also is input to the variable length encoder 111 and is subjected to variable length coding (S18). The acquisition/selection module 110 outputs the selection information 16 used for motion compensated prediction, and inputs it to the selection information encoder 112. The

selection information encoder 112 switches the code table so as to have therein the same number of entries as the available blocks of the encoded blocks neighboring the to-be-encoded block and having motion vectors, and the selection information 17 is subjected to variable length coding. The multiplexer 113 multiplexes the quantized orthogonal transformation coefficient information from the variable length encoder 111 and the selection information to output a bit stream of coded data 18 (S19). The coded data 18 is sent to a storage system (not shown) or a transmission path.

[0023] In the flowchart of FIG. 2, the flow of steps S14 to S17 may be replaced by the flow of steps S18 and S19.

[0024] In other words, the variable length coding step S18 and multiplexing step S19 may be executed following the quantization step S13, and the dequantizing step S14 to the storage step S17 may be executed following the multiplexing step S19.

[0025] The action of the acquisition/selection module 110 will be described referring to flowchart shown in FIG. 3.

[0026] At first the available block candidates being the encoded blocks neighboring the to-be-encoded block and having motion vectors are searched for (S101). When the available block candidates are searched for, the block size for motion compensated prediction of these available block candidates is determined (S102). Next, it is determined whether the available block candidates are a unidirectional prediction or a bidirectional prediction (S103). An available block is extracted from the available block candidates based on the determined result and the prediction mode of the to-be-encoded block. One selection block is selected for from the extracted available blocks, and information specifying the selection block is acquired as selection information (S104).

[0027] There will be described a process for determining a block size referring to FIGS. 4A to 4C (S102).

[0028] The adjacent blocks used in the present embodiment are assumed to be blocks, which are positioned at the left, upper left, upper and upper right of the to-be-encoded block. Therefore, when the to-be-encoded block positions the most upper left of the frame, this to-be-encoded block cannot be applied to the present invention because there is not the available block adjacent to the to-be-encoded block. When the to-be-encoded block is on the upper end of the screen, the available block is only a left block, and when the to-be-encoded block is on the extreme left and not on the extreme upper end, the two blocks of the to-be-encoded blocks which position the upper and upper right thereof.

[0029] When the block size is a size 16x16, the block sizes for motion compensated prediction of the adjacent blocks are four kinds of size 16x16, size 16x8, size 8x16 and size 8x8 as shown in FIGS. 4A to 4C. Considering these four kinds, the adjacent blocks that may be available blocks are 20 kinds as shown in FIGS. 4A to 4C. In other words, there are four kinds for size

16x16 as shown in FIG. 4A, 10 kinds for size 16x8 as shown in FIG. 4B, and six kinds for size 8x8 as shown in FIG. 4C. In discrimination of the block size (S102), the available block is searched for according to the block size from 20 kinds of blocks. For example, when the size of the available block is assumed to be only size 16x16, the available blocks determined by this block size are four kinds of blocks of size 16x16 as shown in FIG. 4A. In other words, the available blocks are a block on the upper left side of the to-be-encoded block, a block on the upper side of the to-be-encoded block, and a block on the left side of the to-be-encoded block and a block on the upper right side of the to-be-encoded block. In addition, even if the macroblock size was expanded not less than size 16x16, it can be the available block similarly to the macroblock size of 16x16. For example, when the macroblock size is 32x32, the block size for motion compensated prediction of the adjacent block are four kinds of size 32x32, size 32x16, size 16x32, and size 16x16, and the adjacent blocks that may be the available blocks are 20 kinds.

[0030] There will be described the determination of the unidirectional prediction or bidirectional prediction which is executed by the acquisition/selection module 110 (S103) with reference to FIG. 5.

[0031] For example, the block size is limited to 16x16, and the unidirectional or bidirectional prediction of the adjacent block with respect to the to-be-encoded block is assumed to be a case as shown in FIG. 5. In discrimination of the unidirectional or bidirectional prediction (S103), the available block is searched for according to the direction of prediction. For example, the adjacent block having a prediction direction L0 is assumed to be an available block determined in the prediction direction. In other words, the upper, left and upper right blocks of the to-be-encoded blocks shown in FIG. 5(a) are available blocks determined in the prediction direction. In this case, the upper left block of the to-be-encoded blocks is not employed. When the adjacent block including the prediction direction L1 is assumed to be the available block determined in the prediction direction, the upper left and upper blocks of the to-be-encoded blocks shown in FIG. 5(b) are available blocks determined in the prediction direction. In this case, the left and upper right blocks of the to-be-encoded blocks are not employed. When the adjacent block including the prediction direction LO/L1 is assumed to be the available block determined in the prediction direction, only the upper block of the to-be-encoded blocks shown in FIG. 5(c) is the available block determined in the prediction direction. In this case, the left, upper left and upper right blocks of the to-be-encoded blocks are not employed. In addition, the prediction direction L0 (L1) corresponds to the prediction direction of the L0 prediction (L1 prediction) in AVC.

[0032] There will be described the selection information encoder 112 referring to flowchart shown in FIG. 6.

[0033] The available block of the encoded block having a motion vector is searched for from among adjacent blocks adjacent to the to-be-encoded block, and the available block information determined by the block size and the unidirectional or bidirectional prediction is acquired (S201). The code tables corresponding to the number of available blocks as shown in

FIG. 8 are switched using this available block information (S202). The selection information 17 sent from the acquisition/selection module 110 is subjected to variable length coding using a changed code table (S203).

[0034] An example of an index of selection information is explained referring to FIG. 7 next.

[0035] When there is no available block as shown in FIG. 7(a), the selection information is not sent because the present invention is inapplicable to this block. When there is one available block as shown in FIG 7(b), the selection information is not sent because a motion vector of an available block used for motion compensation of the to-be-encoded block is determined in unique. When there are two available blocks as shown in FIG. 7(c), the selection information of an index 0 or 1 is sent. When there are three available blocks as shown in FIG. 7(d), the selection information of an index 0, 1 or 2 is sent. When there are four available blocks as shown in FIG. 7(e), the selection information of an index 0, 1, 2 or 3 is sent.

[0036] In addition, as an example of setting an index of the available block, an example of setting the index to the available block in order of the left, upper left, upper and upper right of the to-be-encoded blocks is shown in FIG. 7. In other words, the index is set to the block to be used except for the block which is not used.

[0037] There will be described a code table of the selection information 17 referring to FIG. 8 next.

[0038] The selection information encoder 112 switches the code table according to the number of available blocks (S202). As mentioned above, when there are two or more available blocks, the selection information 17 must be encoded.

[0039] At first when there are two available blocks, indexes 0 and 1 are needed, and the code table is indicated by the table on the left side of FIG. 8. When there are three available blocks, indexes 0, 1 and 2 are needed, and the code table is indicated by the table on the center of FIG. 8. When there are four available blocks, indexes 0, 1, 2, 3 and 4 are needed, and the code table is indicated by the table on the right side of FIG. 8. These code tables are switched according to the number of available blocks.

[0040] There will be explained an encoding method of the selection information.

[0041] FIG. 9 shows a schematic diagram of a structure of syntax used in this embodiment.

[0042] The syntax comprises mainly three parts, wherein High Level Syntax 801 is filled with syntax information of the upper layer not less than a slice. Slice Level Syntax 804 specifies information necessary for every slice, Macroblock Level Syntax 807 specifies a variable length coded error signal or mode information which is needed for every macroblock.

[0043] These syntaxes each comprise more detailed syntaxes. The High Level Syntax 801

comprises syntaxes of sequence and picture levels such as Sequence parameter set syntax 802 and Picture parameter set syntax 803. Slice Level Syntax 804 comprises Slice header syntax 405, Slice data syntax 406 and so on. Further, Macroblock Level Syntax 807 comprises macroblock layer syntax 808, macroblock prediction syntax 809 and so on.

[0044] The syntax information necessary for this embodiment is macroblock layer syntax 808. The syntax is described hereinafter.

[0045] The "available_block_num" shown in FIG. 10 (a) and (b) indicates the number of available blocks. When this is two or more, it is necessary to encode the selection information. In addition, the "mvcopy_flag" indicates a flag representing whether the motion vector of the available block is used in the motion compensated prediction. When there are one or more available blocks and the flag is "1", the motion vector of the available block can be used in the motion compensated prediction. Further, the "mv_select_info" indicates the selection information, and the code table is as described above.

[0046] FIG. 10 (a) shows a syntax when selection information is encoded after "mb_type." When, for example, the block size is only size 16x16, the "mvcopy_flag and mv_select_info" needs not be encoded if the "mb_type" is other than 16x16. If mb_type is 16x16, mvcopy_flag and mv_select_info are encoded.

[0047] FIG. 10 (b) shows a syntax when selection information is encoded before mb_type. If, for example, mvcopy_flag is 1, it is not necessary to encode mb_type. If mv_copy_flag is 0, mb_type is encoded.

[0048] In this embodiment, what order may be employed in a scan order for encoding. For example, a line scan or a Z scan is applicable to the present invention.

[0049] A video decoding apparatus according to an embodiment will be described with reference to FIG. 11.

[0050] The coded data 18 output from the video encoding apparatus of FIG. 1 is input to a demultiplexer 201 of the video decoding apparatus as encoded data 21 to be decoded through a storage system or a transmission system. The demultiplexer 201 demultiplexes the encoded data 21 to separate the encoded data 21 into quantization orthogonal transformation coefficient information and selection information. The output terminal of the demultiplexer 201 is connected to a variable length decoder 202. The variable length decoder 202 decodes the quantization orthogonal transformation coefficient information and the selection information. The output terminal of the variable length decoder 202 is connected to an adder 206 via a dequantizer 204 and an inverse orthogonal transformer 205. The dequantizer 204 dequantizes the quantized orthogonal transformation coefficient information to transform it to an orthogonal transformation coefficient. The inverse orthogonal transformer 205 subjects the orthogonal transformation coefficient to inverse orthogonal transform to generate a prediction error signal. The adder 206 adds the prediction error signal to the predictive coded video signal from a

prediction image generator 207 to produce a video signal.

[0051] The prediction image generator 207 includes a prediction module 208 and an acquisition/selection module 209. The acquisition/selection module 209 selects a selection block from available blocks using selection information 23 decoded by the selection information decoder 203 of the variable length decoder 202 and sends a motion vector 25 of the selection block to a prediction module 208. The prediction module 208 motion-compensates a reference image stored in a frame memory 210 by the motion vector 25 to produce a prediction image.

[0052] The action of the video decoding apparatus of the above configuration will be described referring to flowchart of FIG. 12.

[0053] The demultiplexer 201 demultiplexes the coded data 21 (S31), and the variable length decoder 202 decodes it to produce quantized orthogonal transformation coefficient information 22 (S32). In addition, the selection information decoder 203 checks the condition of the adjacent block adjacent to a to-be-decoded block and decodes it by switching code tables according to the number of the available blocks of the adjacent encoded blocks having motion vectors as shown in FIG. 8, similarly to the selection information encoder 112 of the encoding apparatus, thereby to produce the selection information 23 (S33).

[0054] The quantized orthogonal transformation coefficient information 22 that is information output from the variable length decoder 202 is sent to the dequantizer 204, and the selection information 23 which is information output from selection information decoder 203 is sent to the acquisition/selection module 209.

[0055] The quantization orthogonal transformation coefficient information 22 is dequantized with the dequantizer 204 (S34), and then subjected to inverse orthogonal transform with the inverse orthogonal transformer 205 (S35). As a result, the prediction error signal 24 is obtained. The adder 206 adds the prediction image signal to the prediction error signal 24 to reproduce a video signal 26 (S36). The reproduced video signal 27 is stored in the frame memory 210 (S37).

[0056] The prediction image generator 207 generates the prediction image 26 using the motion vector of the available block that is the decoded block neighboring the to-be-decoded block and having a motion vector, the motion vector being a motion vector of a selection block selected on the basis of the decoded selection information 23. The acquisition/selection module 209 selects one motion vector from the adjacent blocks on the basis of the available block information of the adjacent block and the selection information 23 decoded with the selection information decoder 203, similarly to the acquisition/selection module 110 of the coding apparatus. The prediction module 208 generates the prediction image 26 using this selected motion vector 25, and sends it to the adder 206 to produce a video signal 27.

[0057] According to the present invention, encoding the selection information according to the number of available blocks allows the selection information to be sent using a suitable code

table, resulting in that additional information of the selection information can be reduced.

[0058] In addition, using the motion vector of the available block for the motion compensated prediction of the to-be-encoded block allows the additional information on the motion vector information to be reduced.

[0059] Furthermore, the motion vector calculation method is not fixed and improves degrees of freedom of motion vector calculation as compared with a direct mode by selecting an appropriate one from among the available blocks.

[0060] The technique of the present invention recited in the embodiment of the present invention may be executed with a computer and also may be distributed as a program capable of causing a computer to execute by storing it in a recording medium such as a magnetic disk (flexible disk, a hard disk, etc.), an optical disk (CD-ROM, DVD, etc.), a semiconductor memory, etc.

[0061] In addition, the present invention is not limited to the above embodiments and may be modified in component within a scope without departing from the subject matter of the invention as defined by the appended claims.

[0062] In addition, it is possible to provide various inventions by combining appropriately a plurality of components disclosed in the above embodiments. For example, some components may be deleted from all components shown in the embodiments. Further, the components of different embodiments may be combined appropriately.

Industrial Applicability

[0063] The apparatus of the present invention is applied to an image compression process in a communication, a storage and a broadcast.

REFERENCES CITED IN THE DESCRIPTION

This list of references cited by the applicant is for the reader's convenience only. It does not form part of the European patent document. Even though great care has been taken in compiling the references, errors or omissions cannot be excluded and the EPO disclaims all liability in this regard.

Patent documents cited in the description

- JP4020789B [0004]
- US7233621B [0004]
- WO2008086316A [0006]

Non-patent literature cited in the description

- **JUNG et al.** RD-optimized competition scheme for efficient motion prediction Visual Communications and Image Processing, 2007, [0005]

VIDEOAFKODNINGSANORDNING OG VIDEOAFKODNINGSFREMGANGSMÅDE

PATENTKRAV

1. Videoafkodningsanordning, der omfatter:

5 et hentningsmodul (209), der er konfigureret til at hente tilgængelige blokke med bevægelsesvektorer fra afkodede blokke stødende op til en blok, der skal afkodes, og antallet af de tilgængelige blokke;

10 et udvælgelsesinformationsafkodningsmodul (203), der er konfigureret til at udvælge en kodetabel fra en flerhed af kodetabeller afhængigt af antallet af de tilgængelige blokke, og til at afkode udvælgelsesinformationer, der nærmere angiver en tilgængelig blok fra de tilgængelige blokke, ved hjælp af den udvalgte kodetabel, hvilken udvalgt kodetabel indbefatter det samme antal indekser som antallet af de tilgængelige blokke og kodeord svarende til indekserne;

et udvælgelsesmodul (209), der er konfigureret til at udvælge én tilgængelig blok fra de tilgængelige blokke ifølge udvælgelsesinformationerne; og

15 et billedafkodningsmodul til afkodning af den blok, der skal afkodes, ved hjælp af en bevægelsesvektor fra den udvalgte blok.

2. Videoafkodningsfremgangsmåde, der omfatter:

hentning af tilgængelige blokke med bevægelsesvektorer fra afkodede blokke stødende op til en blok, der skal afkodes, og antallet af de tilgængelige blokke;

20 udvælgelse af en kodetabel fra en flerhed af kodetabeller afhængigt af antallet af de tilgængelige blokke;

afkodning af udvælgelsesinformationer, der nærmere angiver én tilgængelig blok fra de tilgængelige blokke, ved hjælp af den udvalgte kodetabel, hvilken udvalgt kodetabel indbefatter det samme antal indekser som antallet af de tilgængelige blokke og kodeord svarende til indekserne;

25 udvælgelse af én tilgængelig blok fra de tilgængelige blokke ifølge udvælgelsesinformationerne; og afkodning af blokken, der skal afkodes, ved hjælp af en bevægelsesvektor fra den udvalgte blok.

3. Computerprogram til at bevirke, at en computer udfører

et trin med hentning af tilgængelige blokke med bevægelsesvektorer fra afkodede blokke stødende op til en blok, der skal afkodes, og antallet af de tilgængelige blokke;

30 et trin med udvælgelse af en kodetabel fra en flerhed af kodetabeller afhængigt af antallet af de tilgængelige blokke;

et trin med afkodning af udvælgelsesinformationer, der nærmere angiver én tilgængelig blok fra de tilgængelige blokke, ved hjælp af den udvalgte kodetabel, hvilken udvalgt kodetabel indbefatter det samme antal indekser som antallet af de tilgængelige blokke og kodeord svarende til indekserne;

35 et trin med udvælgelse af én tilgængelig blok fra de tilgængelige blokke ifølge udvælgelsesinformationerne; og

et trin med afkodning af den blok, der skal afkodes, ved hjælp af en bevægelsesvektor fra den udvalgte blok.

DRAWINGS

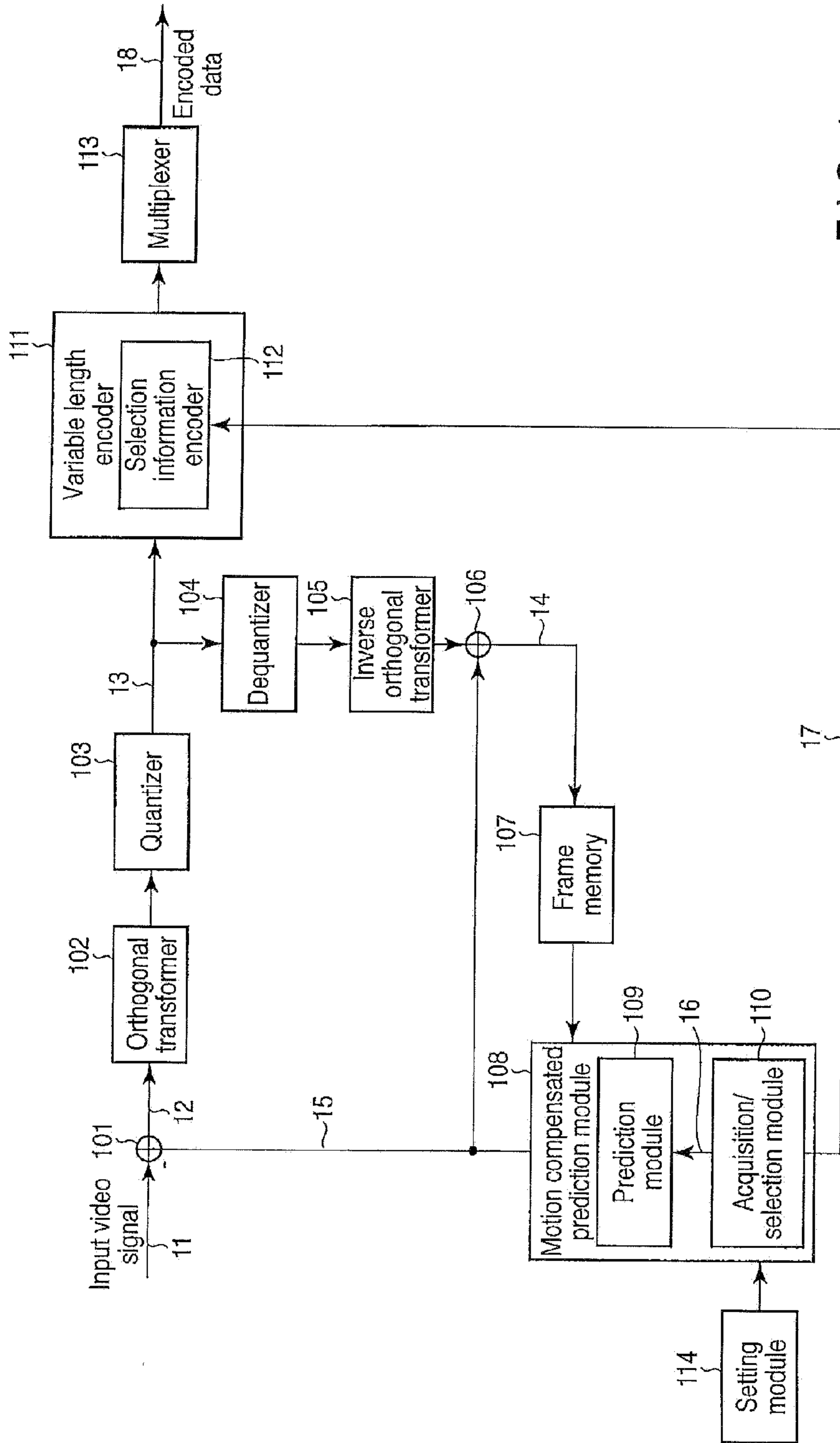

FIG. 1

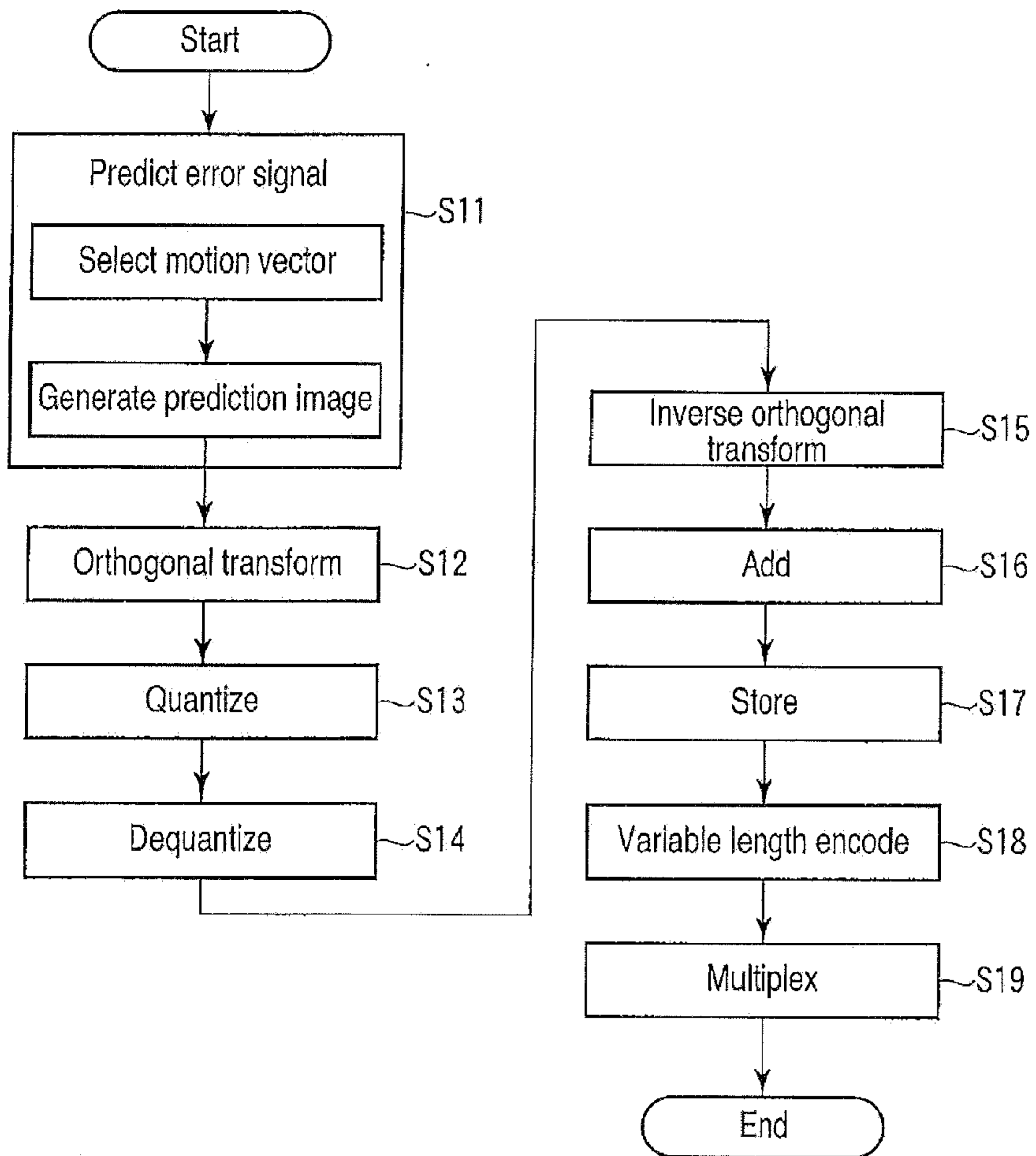

FIG. 2

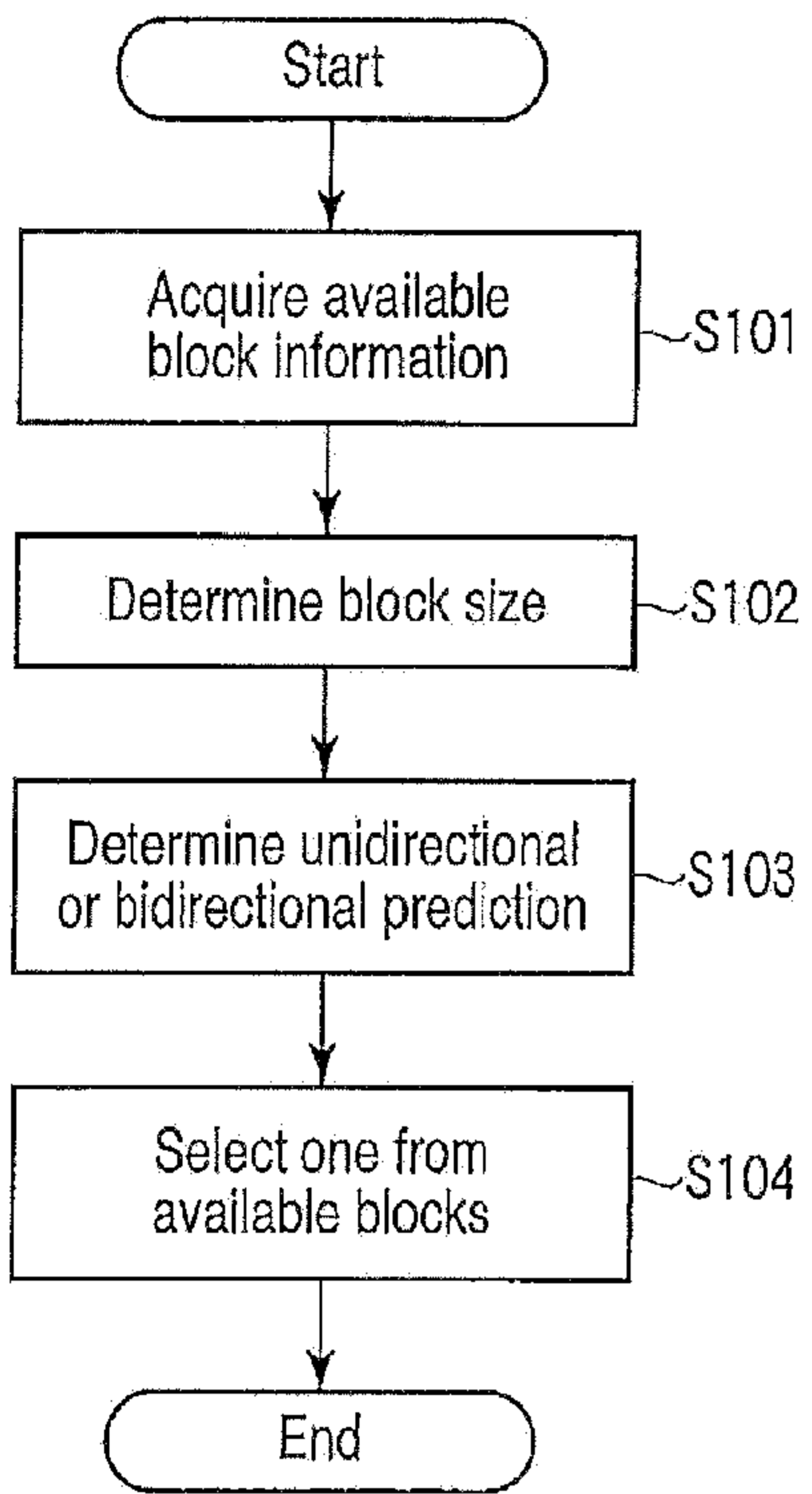

FIG. 3

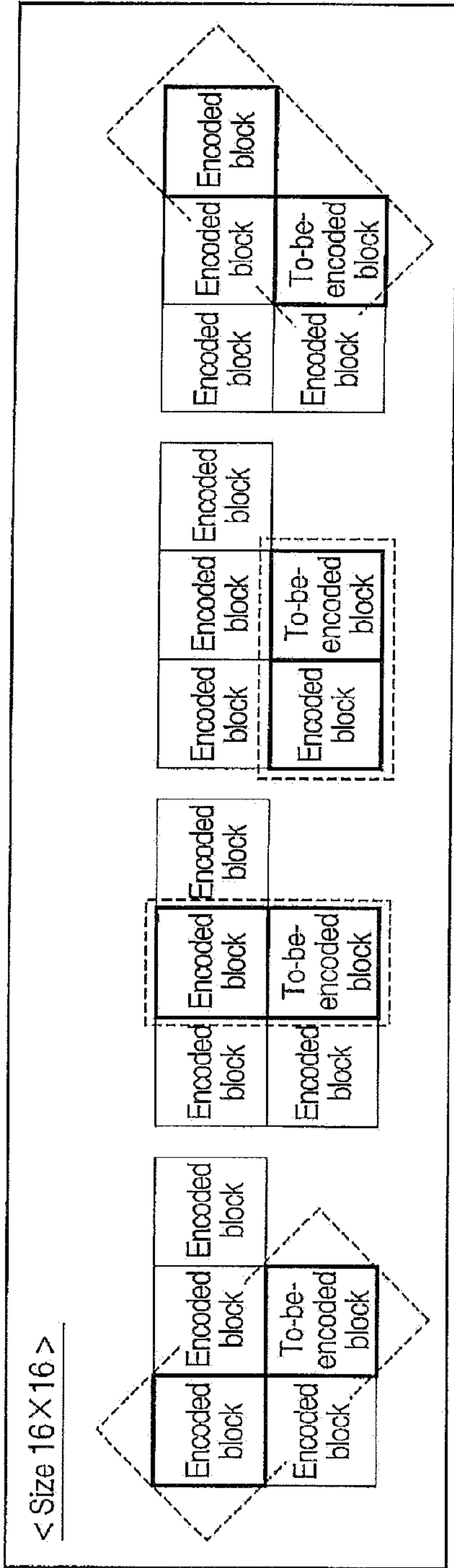

FIG. 4A

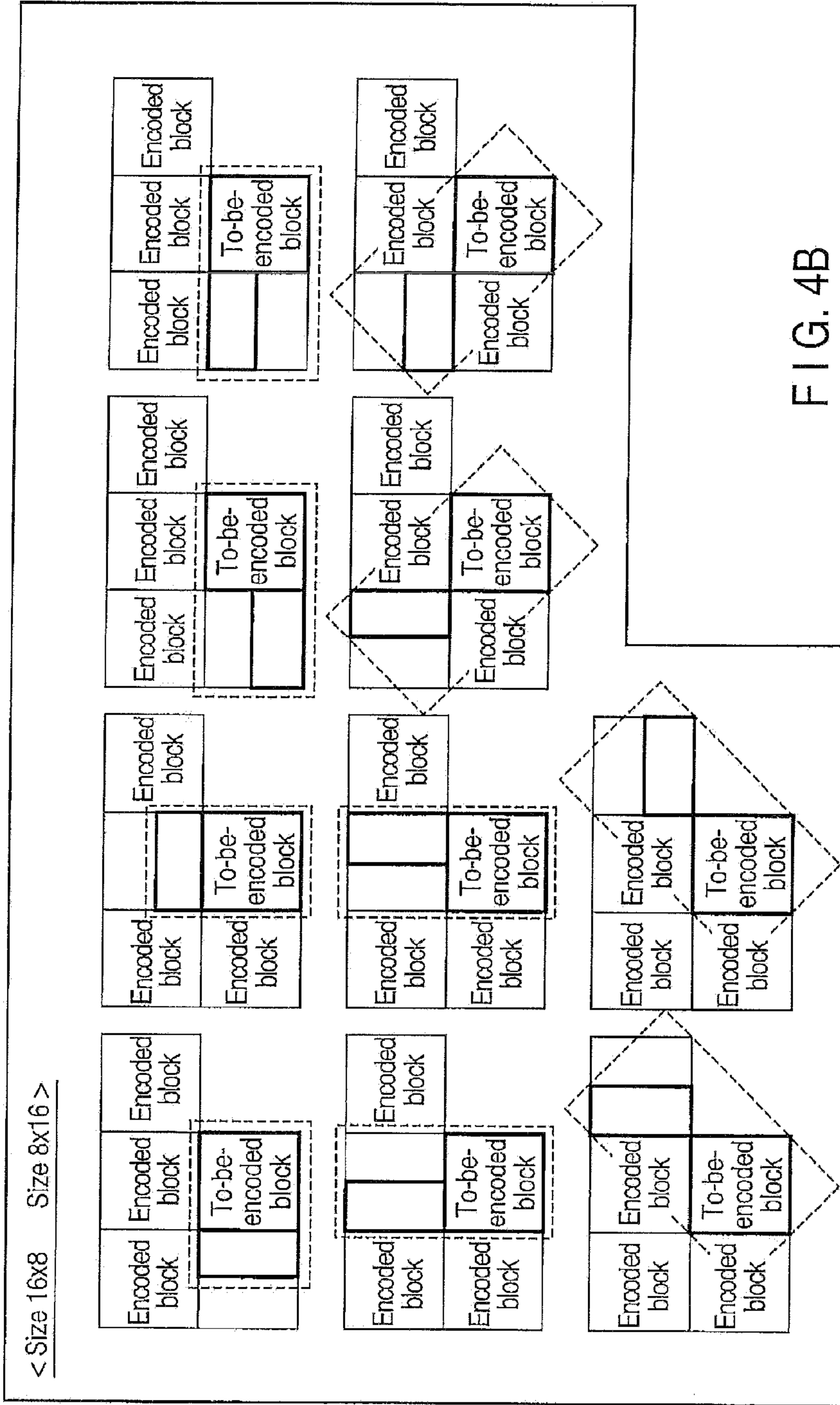

FIG. 4B

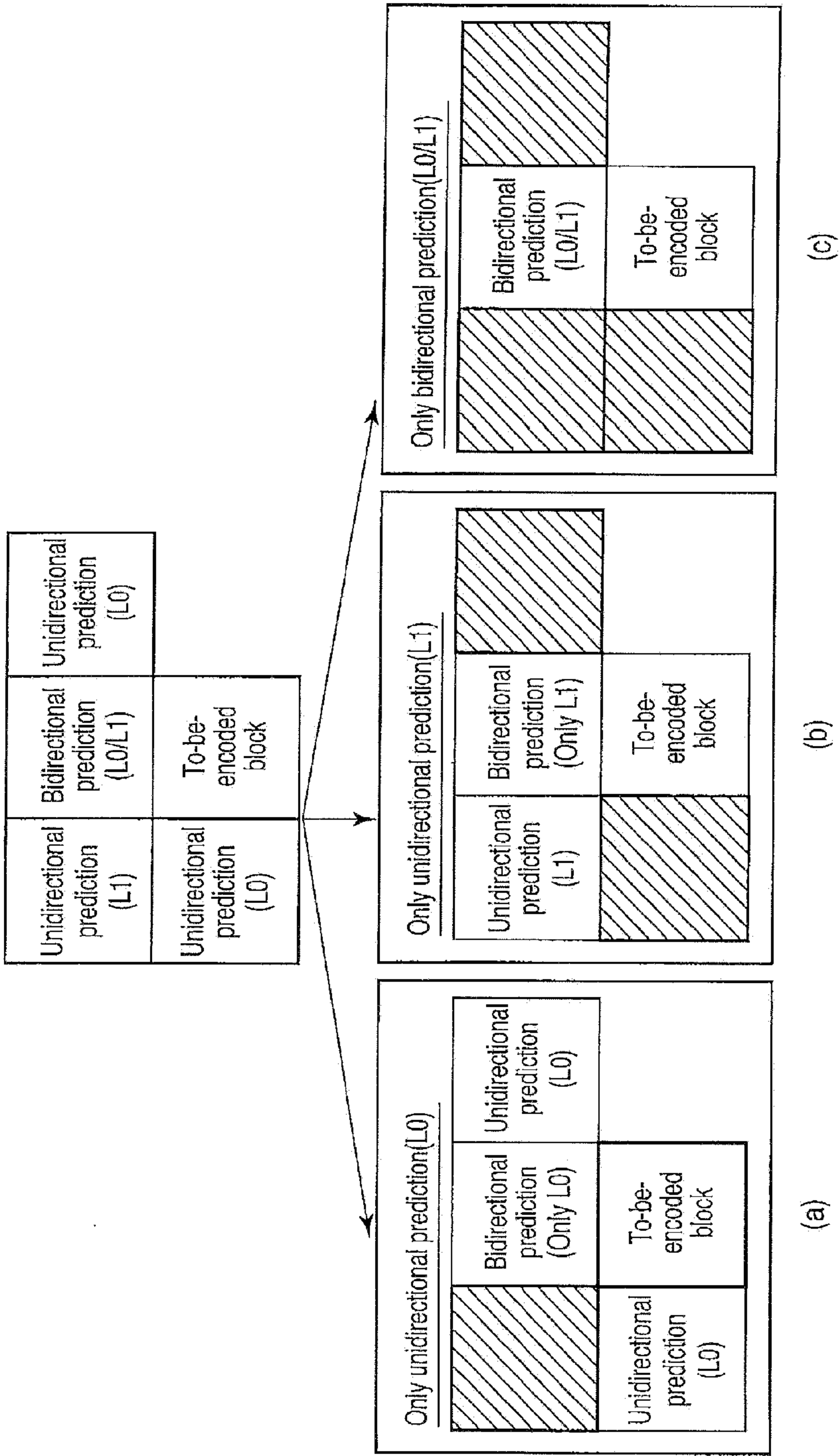

FIG. 5

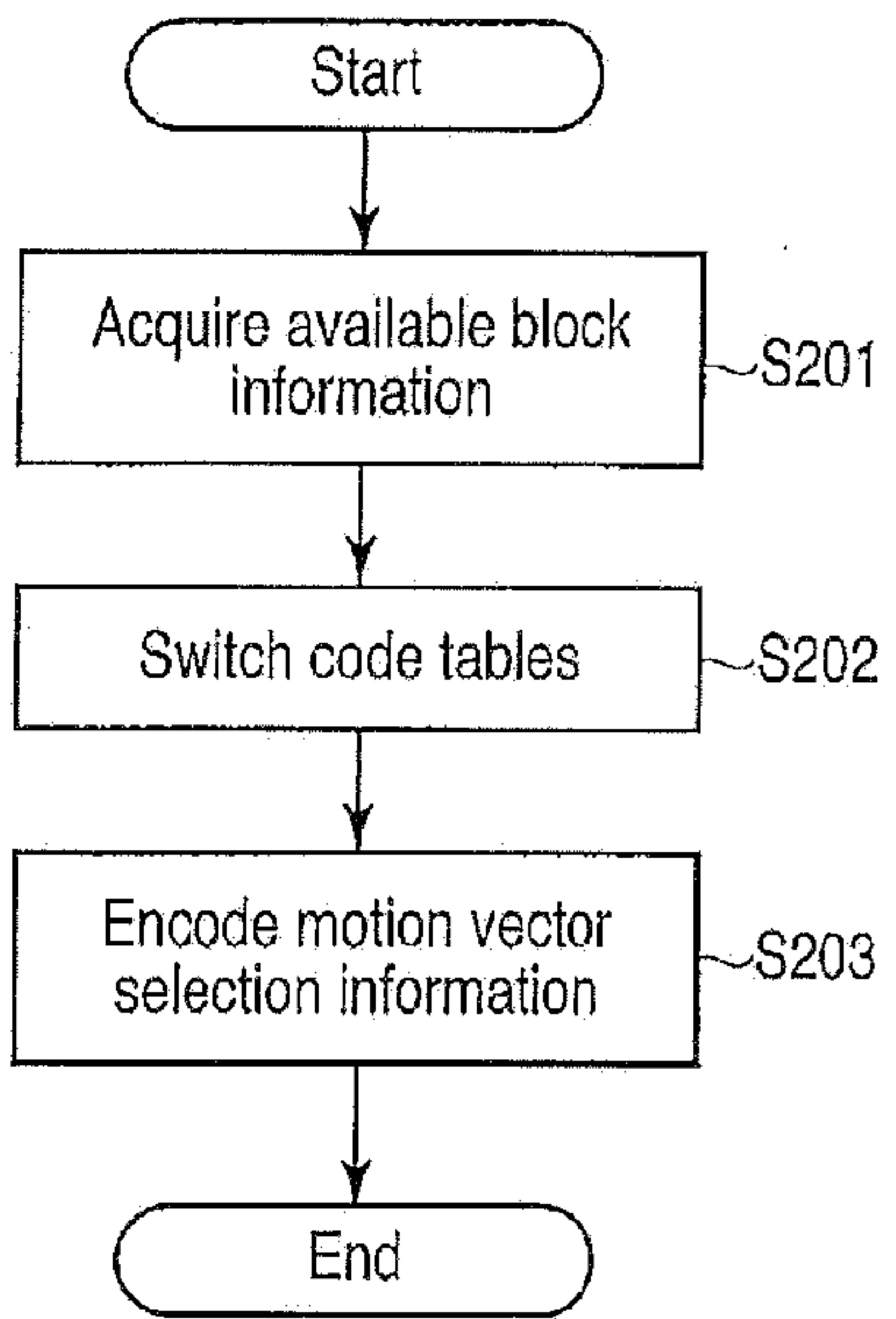

FIG. 6

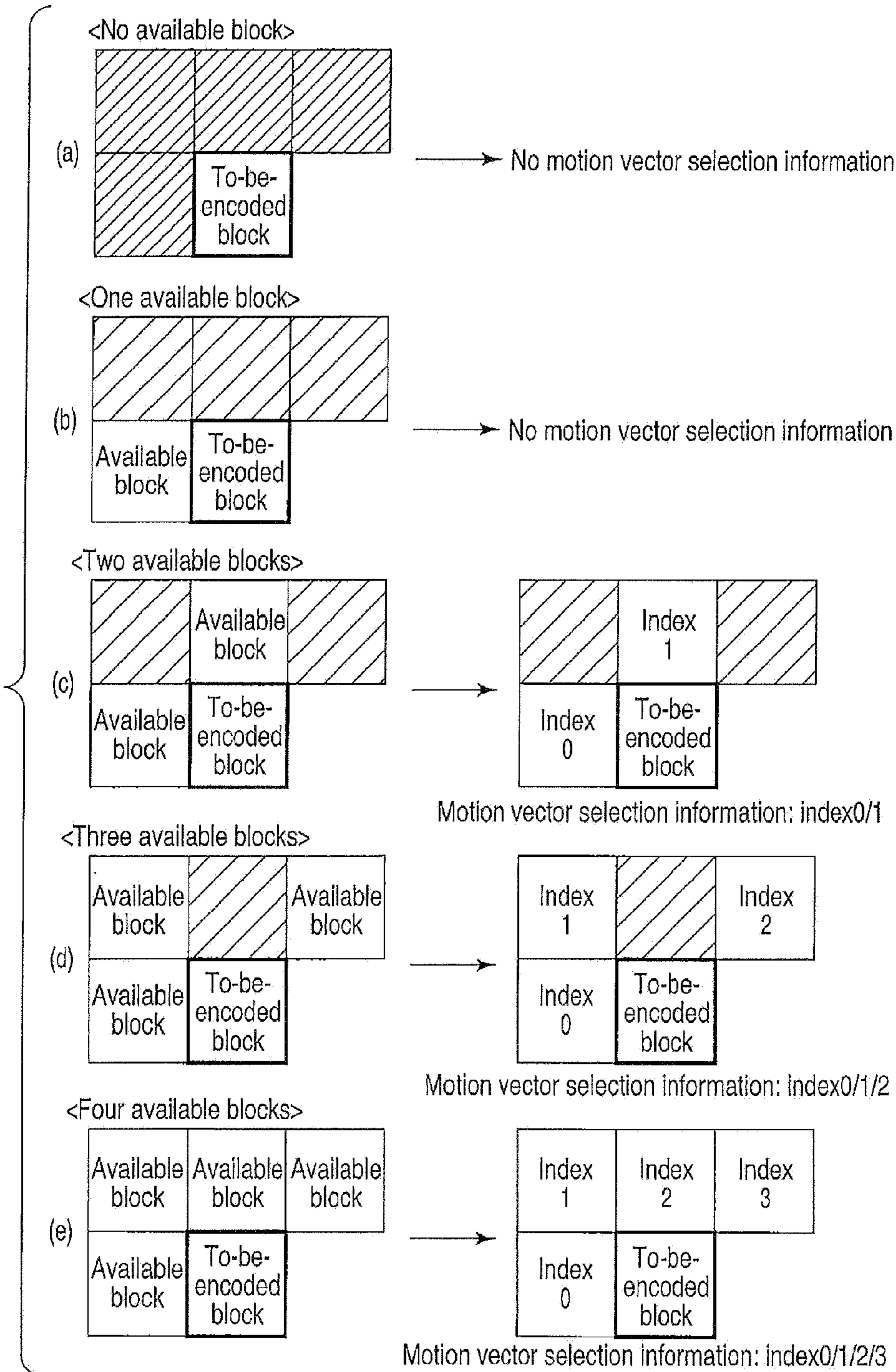

FIG. 7

<Two available blocks>		<Three available blocks>		<Four available blocks>	
Index	Code word	Index	Code word	Index	Code word
0	0	0	0	0	0
1	1	1	10	1	10
		2	11	2	110
				3	111

FIG. 8

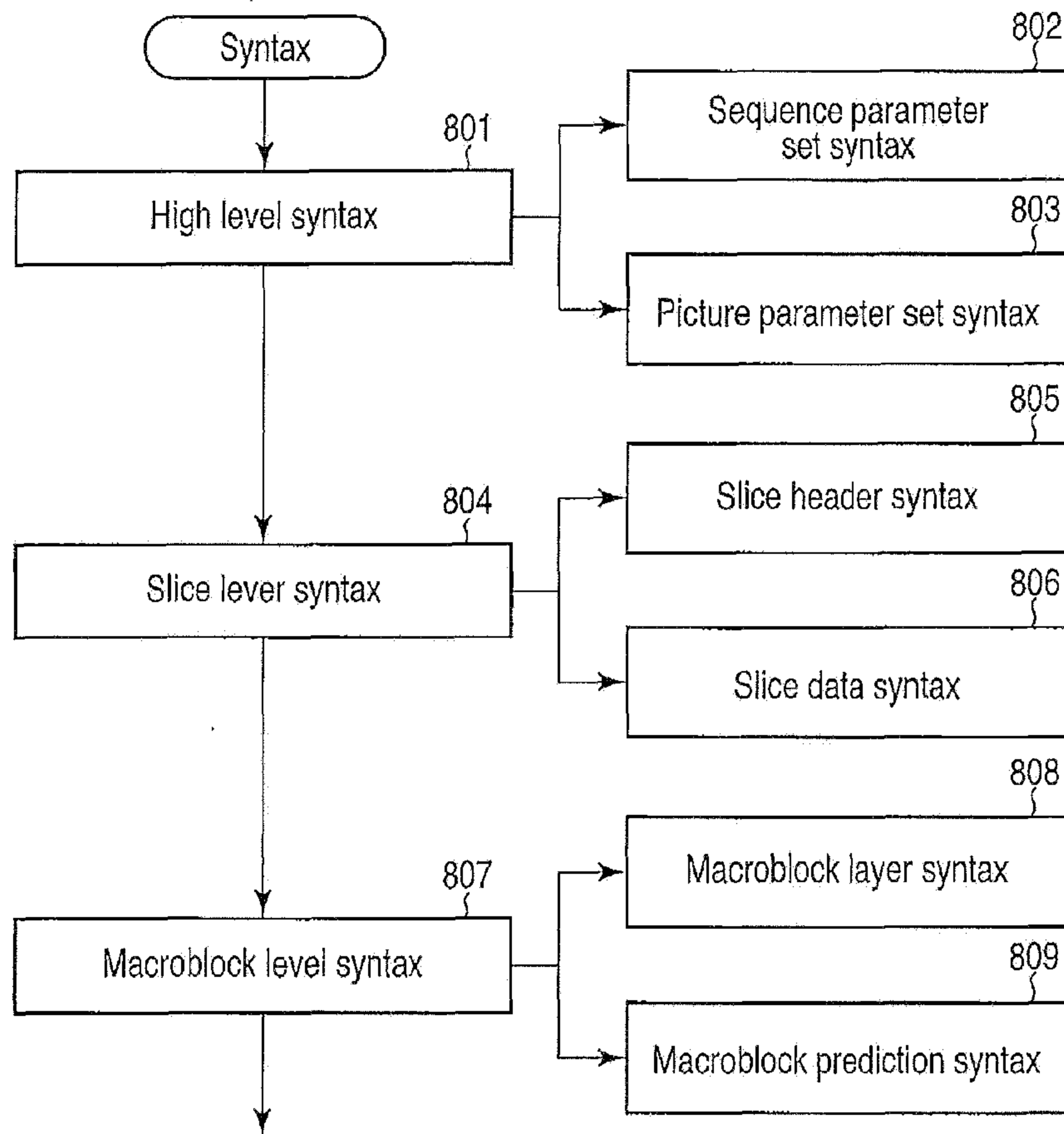

FIG. 9

```
Macroblock_layer( ){  
  mb_type  
  if (available_block_num>0)  
    mv_copy_flag  
  if (mvcopy_flag && available_block_num>1)  
    mv_select_info  
  ...  
}
```

(a)

```
Macroblock_layer( ){  
  if (available_block_num>0)  
    mv_copy_flag  
  if (mvcopy_flag && available_block_num>1)  
    mv_select_info  
  if (mvcopy_flag == 0)  
    mb_type  
  ...  
}
```

(b)

FIG. 10

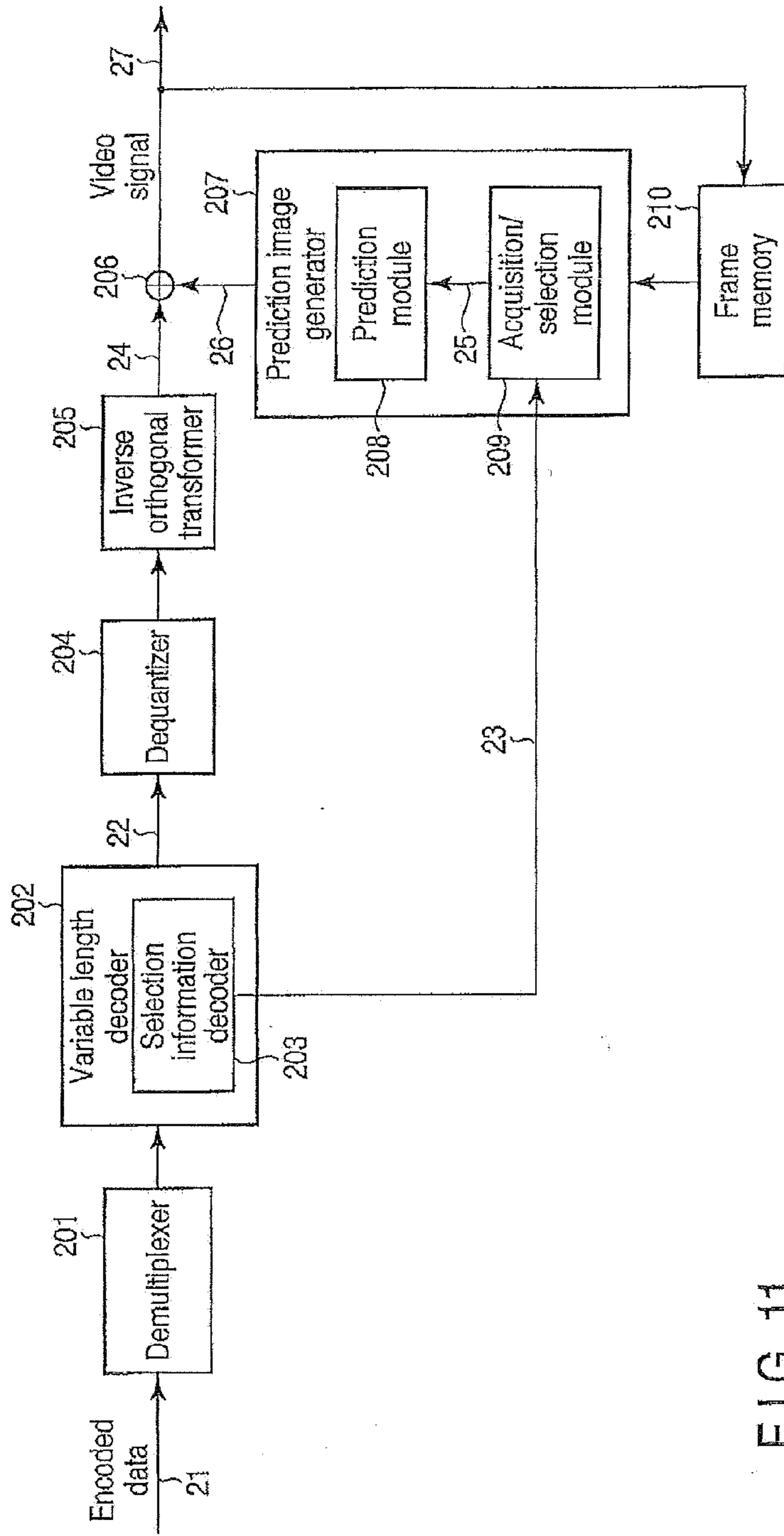

FIG. 11

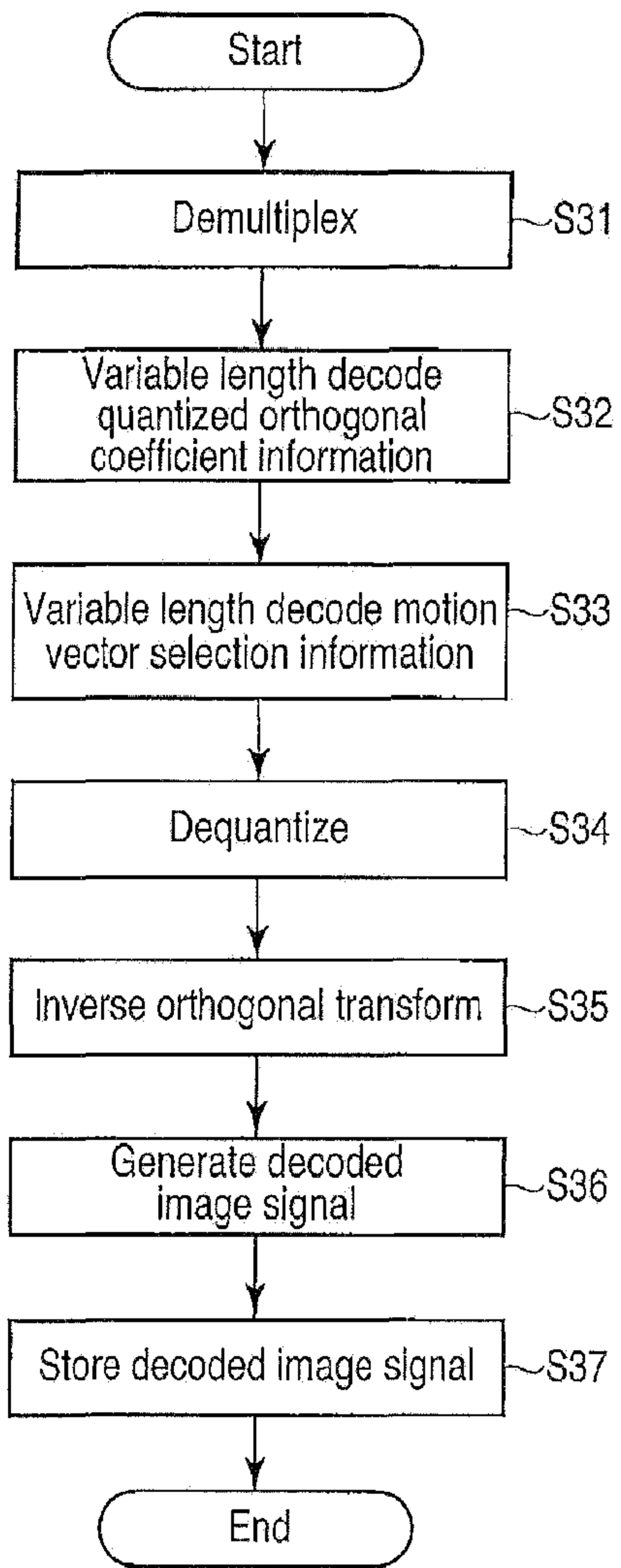

FIG. 12