

[54] **METHOD AND APPARATUS FOR MAKING LEAD STRIP**

[72] Inventors: **Franz Baier**, Teichstrasse 3, Saerback; **Rudolf Schmitz**, Austum 43., Emsdetten, both of Germany

[22] Filed: **Dec. 3, 1970**

[21] Appl. No.: **94,765**

**Related U.S. Application Data**

[62] Division of Ser. No. 580,326, Sept. 16, 1966.

[30] **Foreign Application Priority Data**

Oct. 15, 1965 Germany .....4494634

[52] U.S. Cl. ....156/438, 156/54, 156/201

[51] Int. Cl. ....B65h 45/08

[58] Field of Search .....156/54, 201, 202, 203, 436, 156/438, 461-466

[56]

**References Cited**

**UNITED STATES PATENTS**

3,011,933	12/1961	Barnes et al. ....	156/54 X
3,053,725	9/1962	Uhleen.....	156/499 X
3,320,110	5/1967	Gallagher.....	156/438
2,372,617	3/1945	Trew.....	156/252
2,803,730	8/1957	Kinghorn.....	156/54 X
2,989,430	6/1961	Pulaski.....	156/54 X
3,058,867	10/1962	Plummer et al.....	156/54 X

*Primary Examiner*—Benjamin A. Borchelt

*Assistant Examiner*—H. J. Tudor

*Attorney*—Craig, Antonelli, Stewart & Hill

[57]

**ABSTRACT**

A method and apparatus for making a lead strip to be secured to the lower edge of a curtain or drape as weight means in which the individual lead members are disposed in and surrounded by a relatively thin, hose-like sleeve made from a polyterephthalate foil strip which is formed into a tube upon insertion of the lead member, by means of a glued seam.

**13 Claims, 7 Drawing Figures**

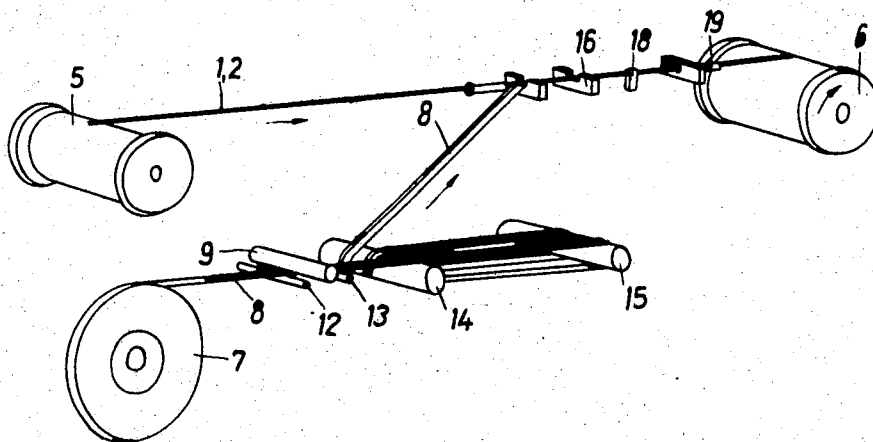

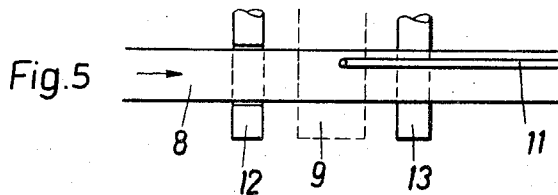
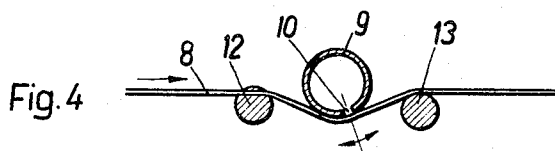
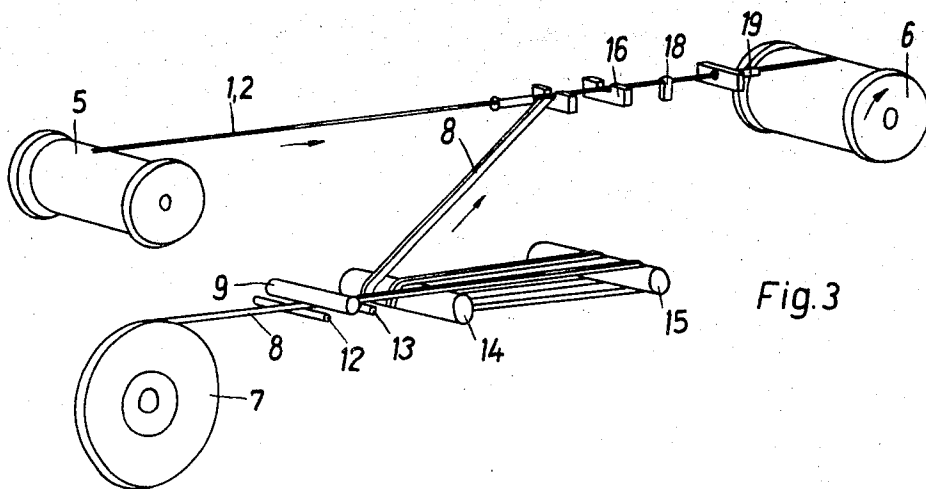
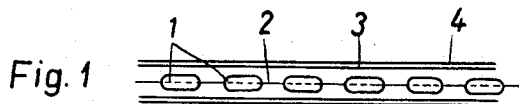

Inventors  
FRANZ BAIER  
RUDOLF SCHMITZ  
BY Craig, Antonelli,  
Stewart & Hill  
ATTORNEYS

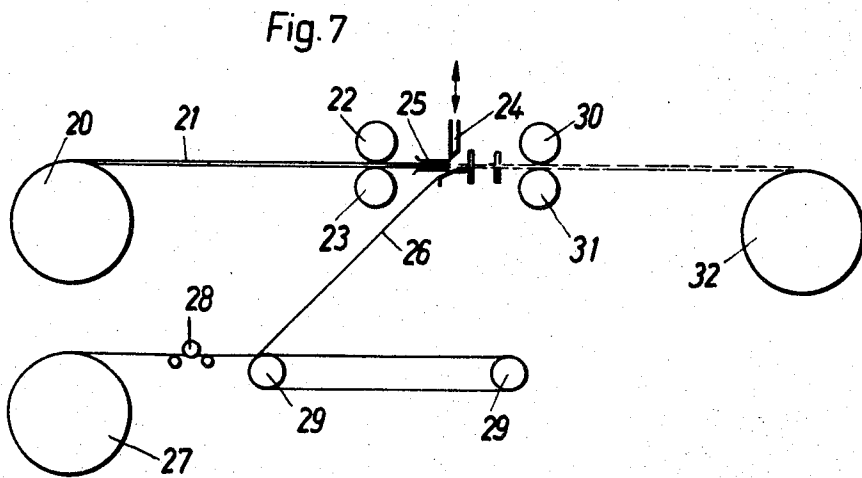
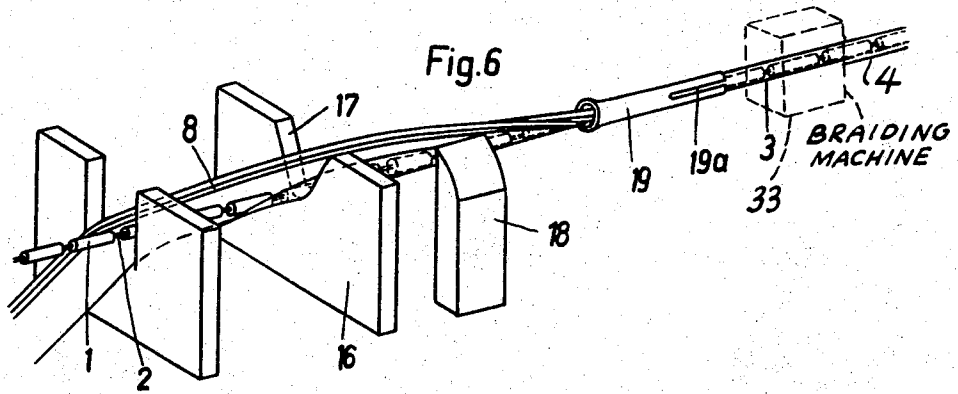

Inventors  
FRANK BAIER  
RUDOLF SCHMITZ  
By Craig, Antonelli,  
Stewart & Hill  
ATTORNEYS

## METHOD AND APPARATUS FOR MAKING LEAD STRIP

The present invention is a divisional application of Ser. No. 580,326, filed Sept. 16, 1966, relating to a lead strip for weighing down curtains and to apparatus for manufacturing such lead strips.

In order to fit a curtain in front of a window in such a way that it hangs smoothly and may also be attractively draped, the lower end of the curtain is usually provided with a lead strip. This so-called lead strip consists of small lead members, connected by a thread which passes through them. Heretofore, it has been customary to fit this lead strip to the bottom edge of the hanging curtain after previously providing a more or less wide seam thereon. More recently, the lead strip has been incorporated, i.e., worked into the material web, while the seam has been omitted. Owing to the elimination of the seam, also the stiffening of the lower curtain edge, which has hitherto been provided by this seam, has been eliminated, and the incorporation of the lead strip directly into the material supports the smooth hanging and draping of the curtain in vertically extending folds.

In order to achieve this purpose, the lead strip must be as flexible as possible.

Heretofore, the lead strip consisting of individual lead members, has been enveloped into a fabric sleeve in order to avoid the dark line otherwise created by the lead strip. However, it has become apparent that there occurs a discoloration of the fabric sleeve, caused by the lead strip due to atmospheric influences.

The present invention has the object of providing a lead strip which is fitted preferably to the lower edge of a hanging curtain or the like and acts as weighing down means, having the maximum possible flexibility, and avoiding, on the other hand, the risk of discoloration of the material enveloping the lead strip.

According to the invention, this object may be realized in a surprisingly efficient manner by enveloping the lead strip within a hose of foil material. A particularly suitable material for this purpose is a foil material of polyterephthalate, a product marketed under the Trade Names of "Hostaphan" or "Hostaphan PW."

Such foil material has an extraordinarily small wall thickness, combined with a very high tensile strength and a very high degree of flexibility. In addition, it is practically steamproof and highly heat resistant.

If a lead strip of the type hereinbefore described is provided with an envelope made from such foil material, its diameter remains practically unchanged, and is determined only by the diameter of the lead members. Due to the high flexibility of such a thin foil strip, the flexibility of the lead strip is in no way impaired, and the known flexibility of the lead strip, consisting exclusively of individual members is fully maintained, its diameter remains practically the same and discoloration of the strip cannot occur which might be transferred to the curtain material.

This lead strip with an envelope made from foil material fulfills its object without discoloration to such a degree that an additional envelope of textile material is no longer necessary. However, in order to provide for the curtain or drape the attractive and customary appearance, the additional envelope of textile material may, of course, be provided. In this case, it is not visible at all from the outside that there is a thin sleeve of foil material between the lead strip and the textile sleeve. This strip with foil envelope and with textile sleeve has the advantage that the flexibility of the lead strip is maintained, which is a prerequisite that the draping of the curtain with completely parallel vertical folds can be assured.

According to the present invention, the strip may be a foil strip which is placed about the lead strip and is closed by a longitudinal glued seam to form a hose.

In this case it is not absolutely necessary to use the known lead strip in which the individual members are threaded on a continuous thread, but according to the present invention this thread may be omitted since the lead members are held in

spaced relationship by the foil sleeve. The elimination of the thread improves again the flexibility of the lead strip, and this may be further enhanced by providing a sufficiently wide spacing between the individual members.

The present invention also relates to devices for manufacturing lead strips of this kind with foil material envelopes. In this device, the lead strip may be pulled off a storage reel. This foil strip, for example, "Hostaphan" or "Hostaphan PE" passes a glue applicator and runs then to the lead strip. Then the foil strip is prefolded and subsequently formed by further folding means into the finished hose.

According to the present invention, a drier is preferably installed between the glue applicator and the folder. In this manner, it may be assured that, in accordance with the glue used, this glue has acquired the correct degree of tackiness at the moment when the lead strip or the individual lead members come into contact with the glued strip.

This drier may consist simply in that the glue strip is conveniently passed repeatedly over two spaced delivery rollers.

A very simple and operationally reliable glue applicator is also realized if one uses a glue quill shaft whose glue outlet orifice is in contact with the foil strip. Such a quill shaft enables the quantitative control of the glue application, simply by pivoting the quill.

If, according to the invention a lead strip is to be used in which the individual members are not connected by a thread, the device according to the invention may comprise an arrangement for pulling a lead wire off a storage reel which is cut by a cutting device into individual cylindrical lead members. The arrangement is such that the individual lead members reach the prefolded foil strip in spaced apart relationship, wherein possibly these members are individually glued to the foil strip. Then the prefolded foil strip is folded by suitable folding devices to form the final hose shaped sleeve.

After finishing the lead strip with the foil sleeve, it may be conducted to a braiding machine which provides an additional textile sheath.

The invention will now be further described by way of example with reference to the accompanying drawings in which:

FIG. 1 is an axial cross-section through a lead strip with foil sleeve and textile envelope according to the present invention;

FIG. 2 is an axial cross-section through a modification of a lead strip according to the present invention;

FIG. 3 shows diagrammatically and in perspective a device for manufacturing the lead strip of FIG. 1;

FIG. 4 shows a glue applicator in longitudinal cross-section on an enlarged scale;

FIG. 5 is a plan view of the glue applicator of FIG. 4;

FIG. 6 shows the folding device for forming the foil material hoses in perspective and on a larger scale than FIG. 3; and

FIG. 7 shows diagrammatically in side elevation a device for manufacturing a lead strip of FIG. 2.

The lead strip of FIG. 1 consists of individual cylindrical lead members 1, arranged in spaced relationship and connected by a continuous thread 2. This chain of lead members is surrounded by a hose-shaped foil material strip 3 and this foil material envelope of the lead members is additionally surrounded by a textile sleeve 4.

The lead strip of FIG. 2 differs from FIG. 1 only in that its members are not connected by a continuous thread. However, also in this embodiment, the lead members 1 are spaced apart and are again surrounded by a hose-shaped foil sleeve 3 over which is slipped a textile hose 4. In the lead strip of FIG. 2, the individual lead members 1 are held in spaced relationship and in their position only by the foil sleeve 3. Each lead member may also be glued to the foil strip.

The device of FIG. 3 is intended for manufacturing a lead strip as shown in FIG. 1. This strip consisting of lead members 1 and a thread 2 is mounted on a storage reel 5. This lead strip 1, 2 is pulled off the reel 5 by a feed roller 6 which may simultaneously serve as take-up reel.

A second storage reel 7 has wound thereon a foil strip 8 consisting of a polyterephthalate, a product marketed under the trade name "Hostaphan" or "Hostaphan PE."

This foil strip 8 passes after leaving the storage reel 7 first through a glue applicator, consisting of a quill shaft 9 adapted to receive the glue and equipped with a glue discharge aperture or outlet 10 which may take any form necessary for varying the width of the strip of glue discharged. This glue outlet 10 is in contact with the foil strip 8. As shown in FIG. 5, a strip of glue 11 is thereby applied to the foil strip 8 which is supported during its passage through the glue applicator by support rollers 12 and 13, located on both sides of the glue quill shaft 9. In order to be able to adjust the application of the glue quantitatively, the glue quill 9 is pivotable as shown by the arrow in FIG. 4. The direction of movement of the foil strip 8 is indicated by the arrow in FIG. 5.

After passing through the glue applicator, the foil strip 8 with the glue strip 11 passes through a drier. This drier consists of two spaced rollers 14 and 15, of which at least one is positively driven by means now shown. Conveniently, the foil strip 8 passes several times around these rollers 14, 15 before it is fed into a folder. First the strip 8 is prefolded by a folding member 16 having a V-shaped opening 17. The position of this folder 16 is such that the lead strip 1, 2 is fed directly into the folded foil strip 8, as shown in detail in FIG. 6. Once the lead strip 1,2 has entered into the folded edge of the foil strip 8, the folding of the strip is finished by the downstream folding means 18 and 19 to form the hose-shaped sheath 3. The folding means 18 consists of a stationary deflector which folds over one half of the strip 8 inwardly in the direction toward the lead strip 1,2. The other half of the strip 8 is then folded over in the folding means 19 which has a tubular shape and is provided with a slot 19 a at its rear end. The slotted ends of the folding sleeve 19 have the purpose of exerting a pressure onto the foil sleeve so as to ensure the formation of an effective glued seal.

In the embodiment of FIG. 7, a lead wire 21 is pulled off a storage reel 20 by means of a pair of pull-off rollers 22,23. Downstream of this pair of rollers 22, 23 is arranged a cutter device having a vertically movable blade 24 and a guide sleeve 25. Within the zone of this cutter device 24, 25, the foil strip 26 is applied, which is again taken off a storage reel 27 and passes through a glue applicator 28 and a drier 29.

While the foil strip 26 arrives at the cutter 24, 25 it is already provided with a strip of glue, as has been explained with reference to FIGS. 4 and 5. The individual cylindrical lead members 1 come to rest in spaced relationship on the strip and adhere thereto by virtue of the glue. The transformation of the foil strip into a sleeve enveloping the individual lead members 1 is effected again by means of folding devices of the type explained, for example, with reference to FIGS. 3 and 6.

After the formation of the envelope this lead strip which is shown in detail in FIG. 2 passes over feed rollers 30, 31 to a take-up reel 32.

Both in the embodiment of FIGS. 3 to 6 and in the embodiment of FIG. 7, the lead strip with its foil envelope and being of the type shown in FIG. 1 or in FIG. 2 may be supplied to a conventional braiding machine 33 as shown in FIG. 6, where it is provided additionally with a textile sheath.

The cutting device 24, 25, the lead wire feed 22, 23, and the foil strip feed 30, 31 should be interconnected by a suitable gearing so that the length of the individual cylindrical lead members 1 and the gap between two adjacent members can be adjusted as required.

While we have shown and described several embodiments in accordance with the present invention, it is understood that the same is not limited thereto but is susceptible of numerous changes and modifications as known to a person skilled in the art, and we therefore do not wish to be limited to the details as disclosed herein but intend to cover all such changes and

modifications as are encompassed by the scope of the appended claims.

What we claim is:

1. A device for manufacturing a lead strip consisting of lead members spaced from each other and connected by a continuous thread, comprising means including a take-off reel for pulling the lead strip from a storage reel, means for pulling a foil strip off a further storage reel, a glue applicator, means for passing said foil strip through said applicator to the lead strip, first folding means for prefolding the foil strip, a drier mounted between the glue applicator and the first folding means, and second folding means for folding the prefolded foil strip to form a hose about said lead members.

2. A device as claimed in claim 1, characterized in that the drier is such that the foil strip runs repeatedly and successively over two space-apart delivery rollers.

3. A device as claimed in claim 2, characterized in that the glue applicator comprises a quill shaft carrying the glue and having a glue outlet in contact with the foil strip, which is supported by support rollers on either side of the glue quill shaft.

4. A device as claimed in claim 3, characterized in that the glue quill shaft is adapted to be manually pivoted to adjust the quantitative application of glue to the foil strip.

5. A device as claimed in claim 1, characterized in that the glue applicator comprises a quill shaft carrying the glue and having a glue outlet in contact with the foil strip, which is supported by support rollers on either side of the glue quill shaft.

6. A device as claimed in claim 5, characterized in that the glue quill shaft is adapted to be manually pivoted to adjust the quantitative application of glue to the foil strip.

7. A device for manufacturing a lead strip consisting of individual lead members spaced apart and held in position only by a foil sleeve, comprising means including a pair of pull-off rollers for pulling a lead wire from a storage reel, cutting means for cutting the pulled lead wire into individual cylindrical lead members, means providing a prefolded and glued foil strip, means for applying the individual cut lead members in spaced-apart relationship to the prefolded and glued foil strip, and folding means for completing the hose-shaped envelope formed by the foil strip about the lead members.

8. A device as claimed in claim 7, characterized in that the folding means for the foil strip includes a tubular folding sleeve having slots at its rear end.

9. A device as claimed in claim 8, characterized in that the lead strip surrounded by the foil sleeve is supplied to a braiding machine for forming an additional textile sleeve.

10. A device as claimed in claim 7, characterized in that the lead strip surrounded by the foil sleeve is supplied to a braiding machine for forming an additional textile sleeve.

11. A device as claimed in claim 7, characterized in that the cutting means includes a vertically movable blade for cutting the pulled lead wire into individual cylindrical lead members such that the cutting action results in the individual lead member being directly applied to the glued foil strip.

12. A device for manufacturing a lead strip consisting of lead members spaced from each other, comprising means for pulling a foil strip off a storage reel, a glue applicator, means for passing said foil strip through said applicator, means for feeding the lead members to said foil strip in such a manner that the foil strip can be folded about the lead members, first folding means for prefolding the foil strip, a drier mounted between the glue applicator and the first folding means, and second folding means for folding the prefolded foil strip to form a hose about said lead members.

13. A device as claimed in claim 12, characterized in that the drier is such that the foil strip runs repeatedly and successively over two spaced-apart delivery rollers.

\* \* \* \* \*