

[54] **KEYBOARD MUSICAL INSTRUMENT,
 MORE PARTICULARLY FOR USE AS A TOY**

[76] Inventor: **Paolo Bontempi**, via Don Bosco 49,
 Potenza Picena, Italy

[22] Filed: **Dec. 18, 1972**

[21] Appl. No.: **315,969**

[30] **Foreign Application Priority Data**

Dec. 18, 1971 Italy 32592 A/71
 June 30, 1972 Italy 26430 A/72

[52] U.S. Cl. **84/453, 206/13**

[51] Int. Cl. **G10g 5/00**

[58] Field of Search 84/327, 379, 421,
 84/453, 470; 206/13

[56] **References Cited**

UNITED STATES PATENTS

1,900,718 3/1933 Lang 206/13

3,478,159 11/1969 Olson 84/470 X
 3,695,138 10/1972 Andersen 84/470

Primary Examiner—Richard B. Wilkinson
Assistant Examiner—Lawrence R. Franklin
Attorney—Richard C. Sughrue, Robert V. Sloan et al.

[57] **ABSTRACT**

A keyboard musical instrument particularly suited, but not exclusively adapted, for use as a childrens' toy, comprising an elongate instrument body on which are formed the keyboard and other controls, and in which are housed all the sound producing devices of the instrument, and two half shells shaped to surround the instrument to form a carrying case, and also to be fitted back to back to form a supporting base for the body when the instrument is in use. The two half shells can be pivotally coupled by a removable hinge plate which also form a clasp to lock the shells into their two relative positions for the two uses thereof.

13 Claims, 15 Drawing Figures

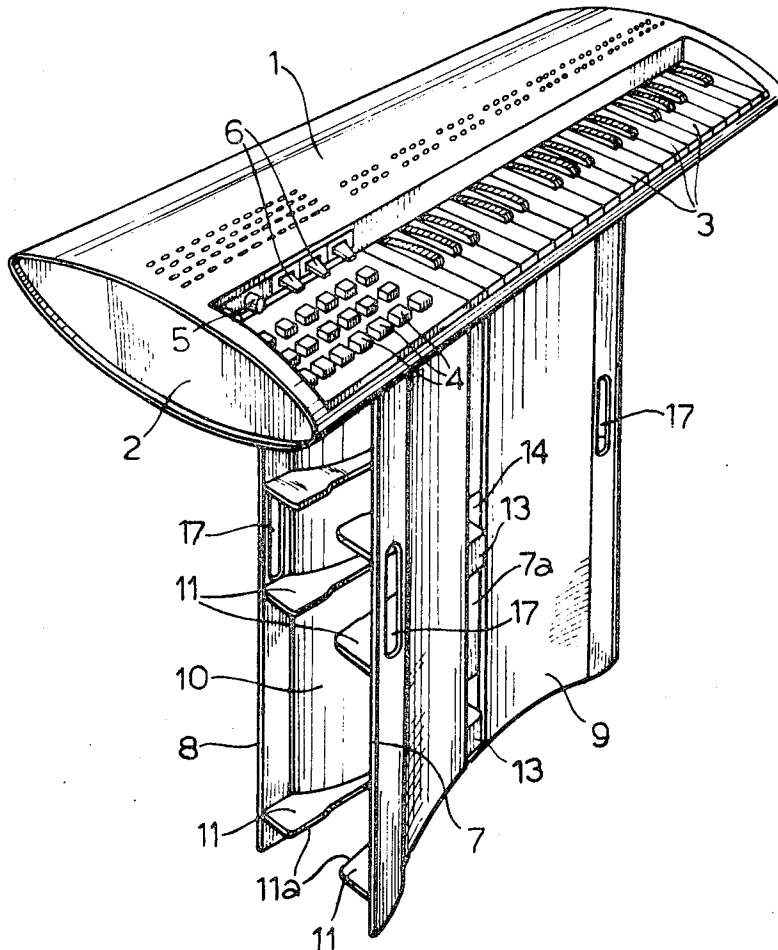

Fig. 1

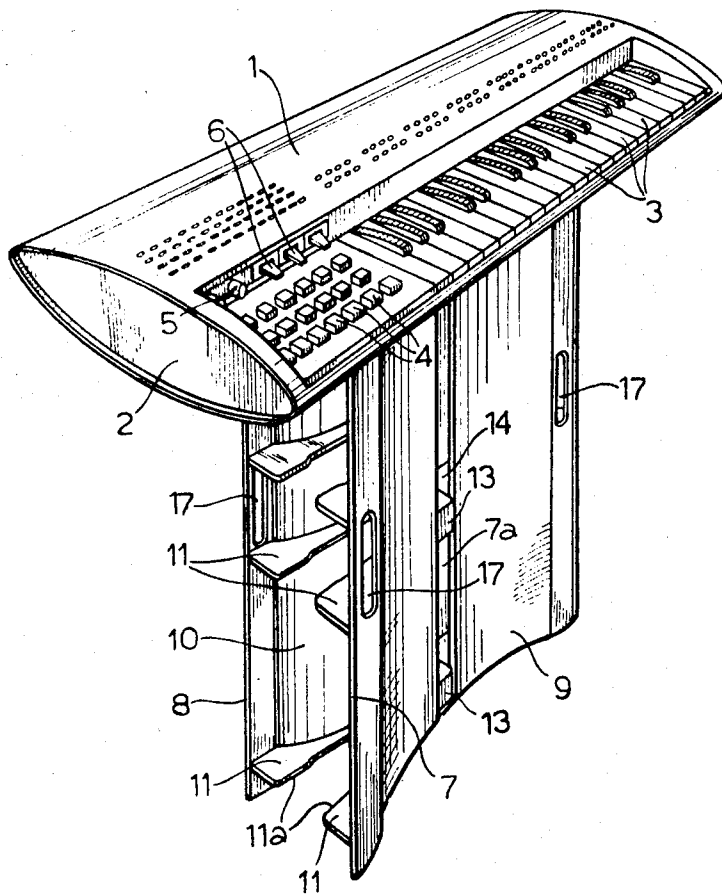

Fig-3

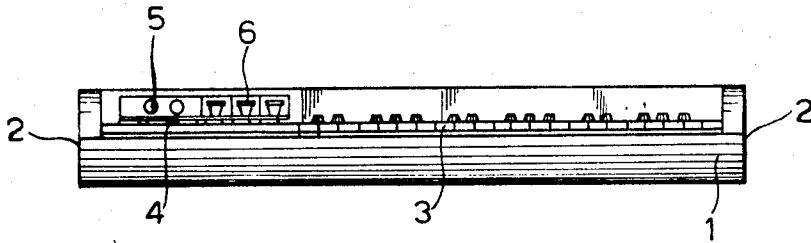

Fig-4

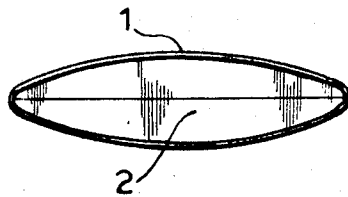

Fig-5

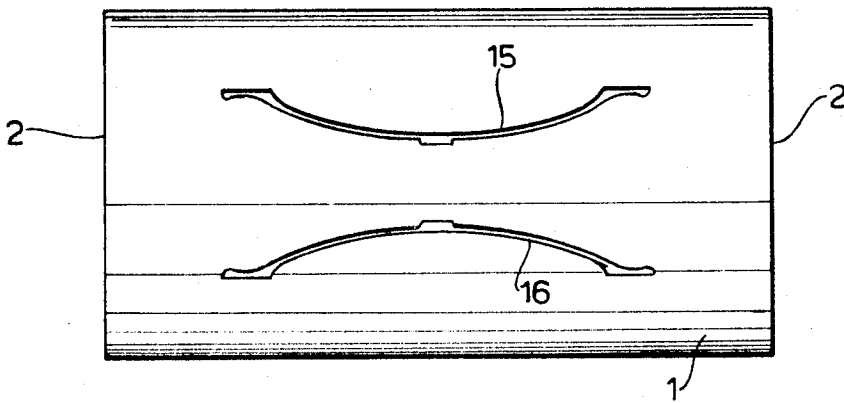

Fig. 6

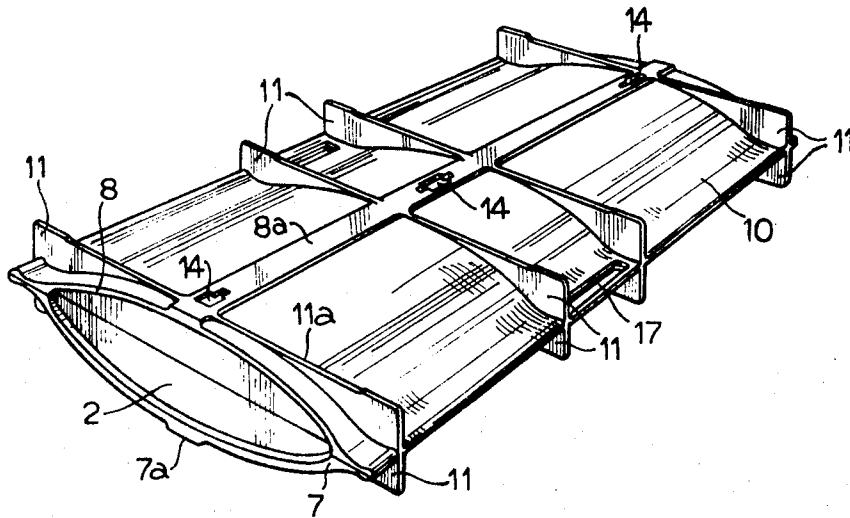
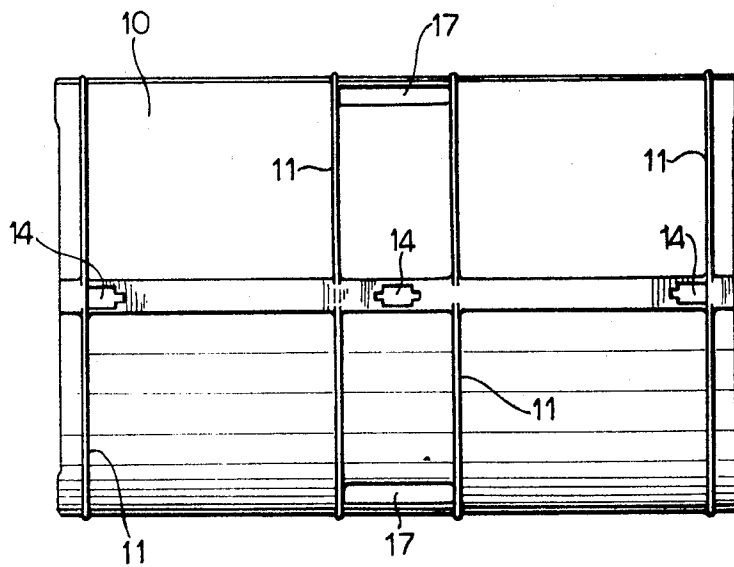

Fig. 7



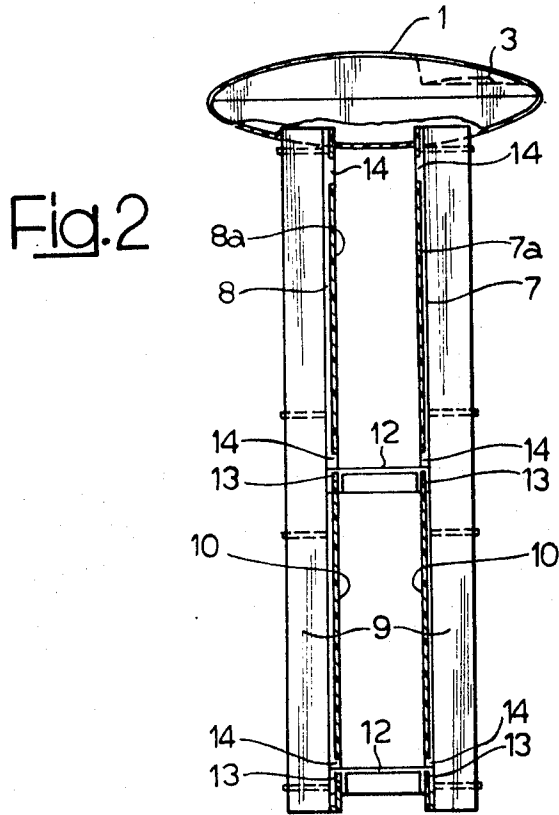

Fig. 8

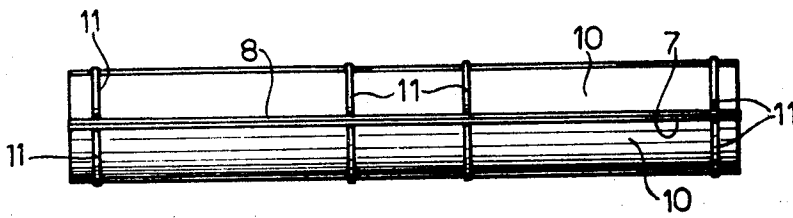

Fig. 9

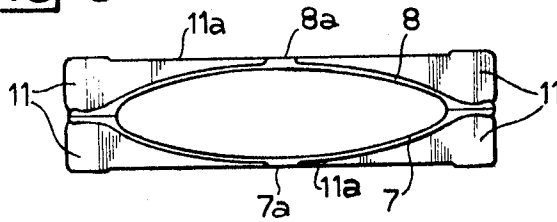

FIG. 10

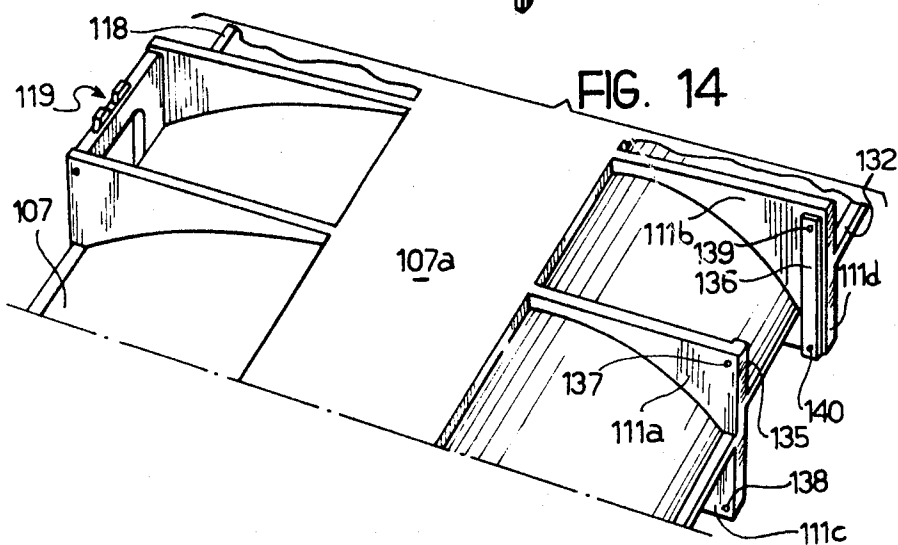
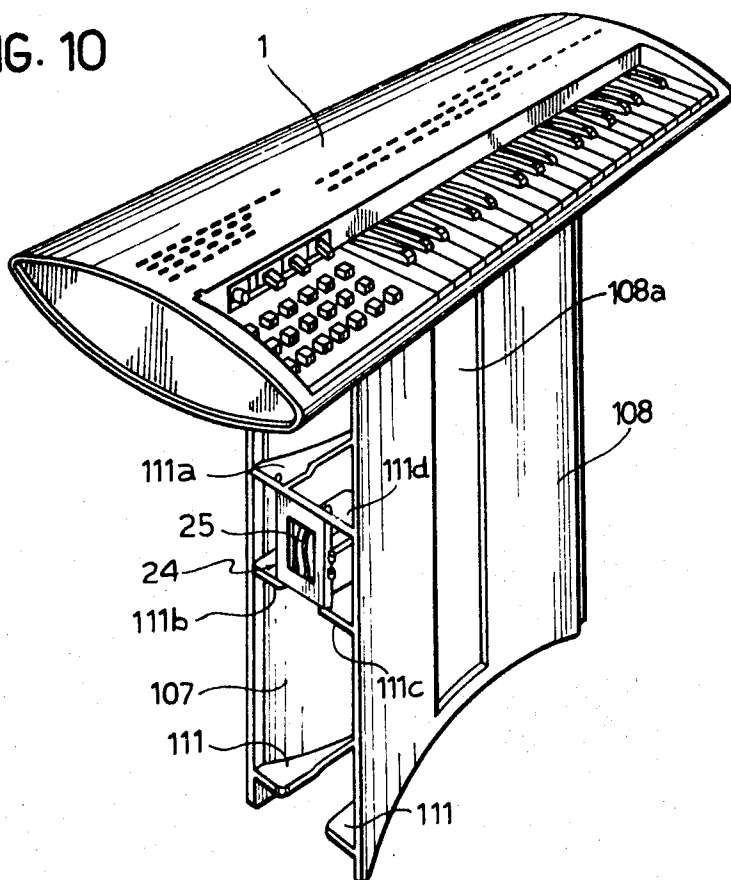

FIG. 15

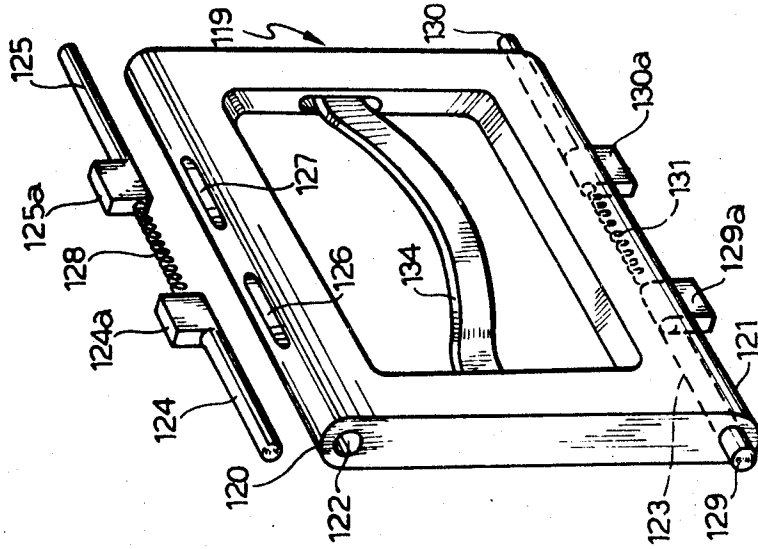
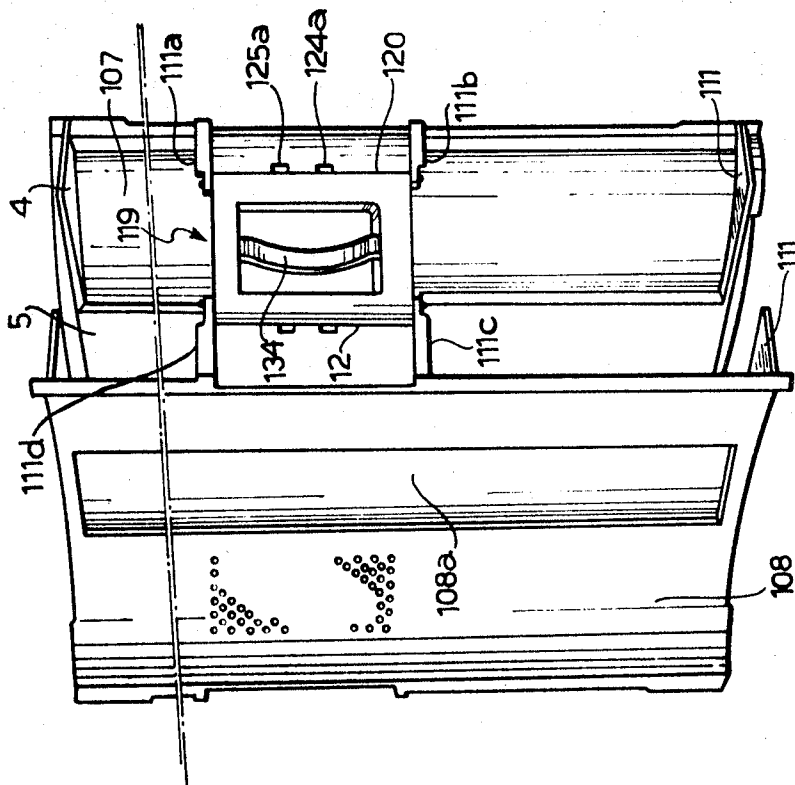
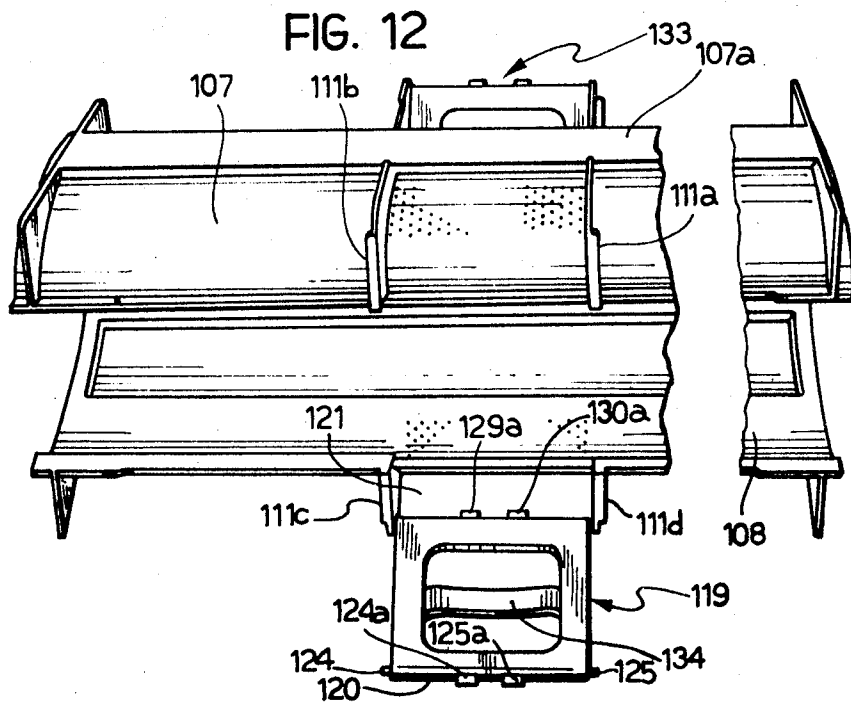
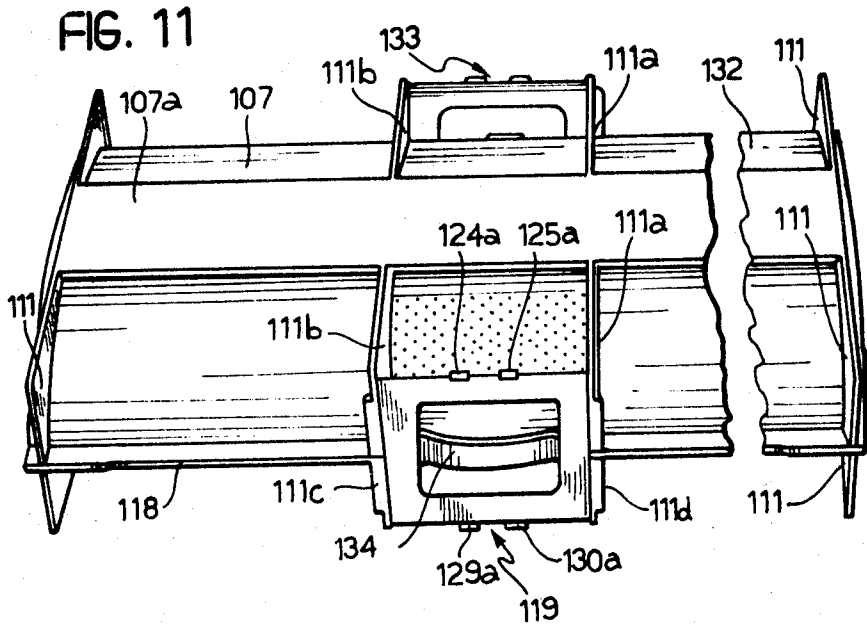

FIG. 13





KEYBOARD MUSICAL INSTRUMENT, MORE PARTICULARLY FOR USE AS A TOY

BACKGROUND OF THE INVENTION

The present invention relates to a keyboard musical instrument such as, for example, a pianoforte organ, or an electric or electronic organ, and particularly to a musical instrument for use as a toy, although embodiments of the invention can be provided for serious use by musicians.

Known musical instruments of this type normally comprise a body within which the sound producing devices are enclosed and on which is mounted a keyboard. The body which is normally longitudinal, is attached to a support consisting of legs or other form of base.

The legs or other form of support for the body of the instrument are constructed solely for the purpose of supporting the body, and when the instrument is stored, or during transport they require to be dismantled from the body and to have separate packing covers and protection from damage, or at least their own packing compartments within a larger container in which the instrument is housed as a whole. When the instrument is to be used, the supporting legs have to be taken out of the packing and assembled to the body.

This arrangement has a number of drawbacks and considerable practical difficulties in that it is necessary to perform separate checks on the legs and the instrument body when these are separated, and also it involves bulky packaging and a considerable amount of space both for storage and for transport.

Embodiments of this invention can be formed with a structure arranged so as to minimize the above mentioned transport and storage difficulties.

Moreover, known types of musical instruments, particularly those constructed as toys for use by children, there is a disadvantage in that children vary considerably in size, and thus require toys of different sizes, both with respect to the height of the keyboard, and also with respect to its length, older children requiring a higher and longer keyboard than younger children. One feature of the present invention is that the height of the keyboard, as determined by a supporting base, can be readily correlated with the length of the keyboard, so that the requirements of younger and older children can readily be accommodated.

SUMMARY OF THE INVENTION

According to the present invention a keyboard musical instrument, comprises a hollow elongate body within which are housed the sound producing devices of the instrument, and two half shells shaped to surround the body when in a first position, to form a protective container therefor, and to form a support for the body when in a second position, the half shells being provided with means for detachably coupling them to one another when in the said first position around the said hollow elongate body and means for removably attaching them to one another and to the body when in the said second position.

Various embodiments of the invention will now be more particularly described, by way of example, with reference to the accompanying drawings, in which:

BRIEF DESCRIPTION OF THE DRAWINGS

FIG. 1 is a perspective diagrammatic view of a musi-

cal instrument formed as one embodiment to the invention, shown in its operating position;

FIG. 2 is a diagrammatic section taken on the line II—II of FIG. 1;

FIG. 3 is a front view of that part of the body of the instrument in which the sound producing elements are located;

FIG. 4 is a side view of that part of the instrument body illustrated in FIG. 3;

FIG. 5 is an underplan view of the part of the instrument body illustrated in FIG. 3;

FIG. 6 is a perspective view of the musical instrument of FIG. 1, shown in a disassembled position;

FIG. 7 is a plan view of the instrument in the position shown in FIG. 6;

FIG. 8 is a front view of the instrument in the position shown in FIG. 6;

FIG. 9 is a side view of the support members of the instrument illustrated in the relative positions they occupy when the instrument is in the position shown in FIGS. 8 and 7;

FIG. 10 is a perspective view of a second embodiment of the invention illustrated in its operating position;

FIGS. 11, 12 and 13 are views, on a larger scale, of various constructional details of the embodiment of FIG. 10 shown in a number of different operating positions;

FIG. 14 is a perspective view of a part of a third embodiment of the invention; and

FIG. 15 is a perspective view of another part of the embodiment of FIG. 14.

DESCRIPTION OF THE PREFERRED EMBODIMENTS

Referring now to FIGS. 1 and 2 of the drawings there is shown a body 1 of a musical instrument, in which the sound producing devices are located. The body 1 extends longitudinally and is substantially rectangular in plan. The cross section of the body 1, on the other hand, is a substantially elliptical shape, and is closed at each end by elliptical end pieces 2.

The body 1 carries a keyboard 3 and a set of push-buttons 4, knobs 5 and stops 6 which form the controls, which are unknown per se in the case of an electric organ. The body 1 is mounted, when in the operating position illustrated in FIG. 1, on a base formed by two semi-elliptical half shells 7 and 8. The half shells 7 and 8 are shaped with the same elliptical curve in cross section as that of the body 1.

The concave surface 9 of the half shells 7 and 8 is smooth and the convex surface 10 of the half shells is provided with a plurality of ribs 11 which project perpendicularly with respect to the longitudinal axis of the half shells. When the instrument is in the operating position the half shells 7 and 8 are placed with their longitudinal axes vertically, as shown in FIGS. 1 and 2, and with their convex surfaces facing each other. The hollow space formed by the concave surface 9 of the half shell 7 on the same side of the body 1 as the keyboard 3, forms a convenient recess for the legs of the user. The junction between the half shells 7 and 8 is formed by means of a plurality of cross pieces 12 which are shaped at their ends with coupling flanges 13 for cooperation with the edges of openings 14 in the medial zones 7a and 8a of the half shells 7 and 8. The under surface of the body 1 (see particularly FIGS. 2 and 5)

has two slots 15 and 16, the shape of which matches the curve of the half shells 7 and 8, and into which the upper ends (see FIG. 2) of the half shells 7 and 8 are fitted when the instrument is in the operating position.

The body 1 is thus firmly anchored to the base, but is removable therefrom by taking the ends of the half shells 7, 8 from the slots.

Referring now to FIGS. 6, 7, 8 and 9, it can be seen that when the instrument is dismantled the half shells 7 and 8 can be placed on either side of the body 1 to form a container therefor. The ends of the body 1, that is the end pieces 2 of the body, remain uncovered. The ribs 11 have one edge 11a which is substantially rectilinear, and these are of such a shape that in the dismantled position illustrated in FIG. 6 the instrument only takes up the space required by a rectangular box having the dimensions of the major and minor axes of the elliptical cross section of the body 1, and the length thereof. A number of such instruments can thus readily be stacked thereby saving considerable space for storage or transport, and this is achieved without the use of any additional elements. The half shells 7 and 8 can be provided with slots 17 (FIGS. 6 and 7) to facilitate manual handling or carrying of the whole instrument when dismantled.

From the above description it will be clear that the musical instrument does not have to be provided with a separate support base or legs in addition to a carrying case since the half shells 7 and 8 which make up the carrying case for storage and transport of the body 1 of the instrument are also used to form the support base when the instrument is assembled in an operating position.

Moreover, the half shells 7 and 8 are at least as long as the body 1 so that the height of the support base formed thereby when the half shells 7 and 8 are placed in the vertical position, will be in direct proportion to the length of the body 1 of the musical instrument.

The problem of proportioning the height of the support base to the length of the body 1 is thus solved automatically.

In FIGS. 10 to 13 there is shown a further embodiment of the invention. In this embodiment the two half shells are indicated 107 and 108 and there is formed a web 119 between two adjacent ribs on each edge of each half-shell 107 and 108 extending substantially parallel to a plane containing the minor axis of the ellipse and the longitudinal axis of the half shell. These webs 110 act to stabilize the positioning of the half shells both when they are coupled to form the casing or container for the body of the musical instrument and when they are attached together to form the pillar-like base (FIG. 10) for the body 1.

The web 119 is conveniently a removable frame formed from a rectangular plate having a large rectangular opening therein (see FIG. 15). In this arrangement there are two elongate bores 122 and 123 extending along respective parallel sides 120 and 121 of the frame. In the bore 122, there is slidably arranged two pins 124 and 124, one end of each of which is formed as a block 124a, 125a to be trapped from sliding movement within a respective lateral opening in the form of a slot 126, 127 in the side of the bore 122. A spring 128 is located in the bore 122 between the blocks 124a, 125a which keeps the said pins 124 and 125 spaced apart from each other and urges them outwardly.

The pins 124, 125 normally project from opposite ends of the said bore 122, for a distance corresponding to the difference between the lengths of the slot openings 126 and 127 and the length of the blocks 124a and 125a at the end of the pins 124, 125.

A similar arrangement to that described for the bore 122 is provided in the bore 123, including pins 129 and 130 urged apart by a spring 131 located between them. The ends of the pins 124, 125, 129 and 130 which project from the plate 119 can be engaged into correspondingly positioned apertures in the ribs 111a, 111d respectively and this engagement connects the two half shells 107 and 108 along their long edges 118 when they are placed with these edges together to form a casing for the body 1 of the musical instrument. In order to complete the coupling of the two half shells a further plate 133 is provided for coupling the middle two ribs of each half shell at the opposite long edge 132 thereof.

The plates 119 and 133 also constitute the connecting elements of the musical instrument when it is in its operating position as shown in FIG. 10. In order to change the plates from the position in which the half shells 107 and 108 form a container or casing for the musical instrument, to the position in which the half shells are positioned to form a support for the body 1 of the instrument (FIG. 10) it is merely necessary to move any two of the blocks at the ends of the pins toward each other, for example the blocks 124a and 125a might be the most readily accessible; this disengages one side 120 of the plate 119 from the ribs 111a and 111b of the half shell 107, thus releasing the engagement between the adjacent edges of one side of the half shells, which are in contact along the line 118. The half shell 107 is then separated from the half shell 108 by pivoting it about the other plate 138, which remains connected, to allow removal of the instrument from within the casings formed by the two half shells. The half shell 107 is then rotated further about the pins of the other plate 133 until the cooperating rib 111 come into contact with one another. The half shells 107 and 108 are then located with their convex faces together. The blocks 124a and 125a are then moved towards one another again to effect re-engagement of the pins 124 and 125 into the apertures in the ribs 111a and 111b. The half shells 107 and 108 are thus locked into the shape of a pillar support, to the top of which the body 1 of the musical instrument can be attached by snapping the upper edges of the said half shells into cooperating slots 15, 16 in the under surface of the said body 1.

By using two identical plate-like elements for locking the two sides of the half shells 107 and 108 together and by providing each of two edges of the said plate-like elements with a symmetrical pair of spring loaded pins it is possible to separate the casing formed by the two half shells to form a supporting base for the instrument by utilising whichever of the plates and sets of pins is most convenient.

The rectangular aperture in the plate is crossed by a handle 134 by means of which a user is able to carry the musical instrument. The plate-like element 119 thus simultaneously fulfils three different functions, that is it provides the means for connecting and locking together the half shells 107 and 108 to form a casing for the musical instrument, the means for locking and stabilizing the half shells 107 and 108 to form support for

the body 1 of the musical instrument, and a carrying handle for transporting the instrument by hand.

In FIG. 14 is shown a third embodiment of the invention. In this embodiment the long edges 118 of the half shells are coupled in the same manner as in the embodiment of FIGS. 10 to 13, by a plate 119, but the other long edges 132 are connected by two bars 135 and 136 which are pivoted at each end to respective ribs 111a, 111c and 111b, 111d in such a way as to provide a hinge which can be turned through 360° to allow the two half shells to be rotated from one position to the other when the plate-like element 119 is disengaged.

Many variations and modifications to the embodiments of the invention described above can be made by changing the details thereof utilizing technically similar elements; similarly the materials used, and the dimensions, may be widely varied without thereby departing from the spirit and scope of the invention.

I claim:

1. A keyboard musical instrument comprising:
 - an elongate body portion within which are housed the sound producing devices of the instrument, said body portion also carrying a keyboard for controlling the operation of said sound producing devices, two elongate half shells of a shape corresponding to the shape of said body portion,
 - means for coupling said half shells in a first relative position where they surround said body portion to form a container therefor, and
 - means for coupling said half shells in a second relative position where they form a supporting base for said body portion to hold it in a position suitable for playing.
2. The keyboard musical instrument of claim 1 wherein said body portion is shaped generally as an elliptical prism, having a substantially rectangular plan form and a substantially elliptical cross section, said half shells having a concave face corresponding in shape to the curve of the said body portion.
3. The keyboard musical instrument of claim 2 wherein said half shells also have a convex face on which there are formed a plurality of identical ribs extending transverse the axis of the half shell, each rib having two substantially straight mutually perpendicular edges.
4. The musical instrument of claim 3 wherein said means for coupling said two half shells comprise:
 - at least one plate attachable to two adjacent said ribs at a point along one of the longer edges of said half shells,
 - means pivotally coupling said plate to said two adjacent ribs of one said half shell,
 - means detachably coupling said plate to said two adjacent ribs of the other said half shell, and
 - means pivotally connecting said other longer edges of said two half shells whereby said two half shells can be rotated between said first position with their concave faces together and said second position with their convex faces together when said detachable coupling of said plate and said two adjacent ribs of said other half shell is detached.

5. The keyboard musical instrument of claim 4 wherein said means pivotally coupling said plate to said one half shell is detachable, and said means detachably coupling said plate to said other half shell is a pivoted coupling.

6. The keyboard musical instrument of claim 5 wherein said coupling means comprise a housing formed along each of two edges of said plate, a pin slidable in each said housing, one end of each said pin projecting from said plate and being retractable against the action of resilient biasing means.

7. The keyboard musical instrument of claim 6 wherein said housings are formed as elongate bores in said plate, extending parallel to two said edges of said plate, there being located to said pins in each said bore, and there are further provided,

spring means in said bore between said two pins and urging two pins apart, and means for limiting the sliding movement of said two pins along said bore.

8. The keyboard musical instrument of claim 7 wherein each said pin is provided with a lateral projection,

elongate slots in the side walls of said bores, said lateral projections extending through said elongate slots, the length of said slots defining the limits of movement of said pins.

9. The keyboard musical instrument of claim 8 wherein said plate is substantially rectangular and has a substantially rectangular aperture therein, and handle means extending across the middle of said aperture parallel to the edges of said plate within which said elongate bores are formed.

10. The keyboard musical instrument of claim 4 wherein said hinge means about which said other edges of said first and second half shells are pivoted comprises a second plate similar to said one plate.

11. The keyboard musical instrument of claim 1 wherein said means for attaching said half shells together in said second position to form said supporting base for said body of said instrument, comprise at least one cross piece having engagement means at each end and said half shells have apertures therein for cooperation with said engagement means.

12. The keyboard musical instrument of claim 1 wherein said half shells are both formed with elongate openings at the mid point adjacent the longer edges thereof, said openings forming a handle for carrying said half shells when in said first position with said concave faces toward one another.

13. The keyboard musical instrument of claim 1 wherein said means for attaching said half shells to said body portion when said half shells are in said second position, comprise a pair of curved openings in the bottom surface of said body portion, said curved openings having a shape corresponding to the cross sectional shape of said half shells, whereby said body portion can be attached to said half shells by inserting said half shells in said second position into said openings in said body portion.

* * * * *