



(12) **DEMANDE DE BREVET CANADIEN
CANADIAN PATENT APPLICATION**

(13) **A1**

(86) **Date de dépôt PCT/PCT Filing Date:** 2022/02/03
(87) **Date publication PCT/PCT Publication Date:** 2022/08/11
(85) **Entrée phase nationale/National Entry:** 2023/07/28
(86) **N° demande PCT/PCT Application No.:** IB 2022/050943
(87) **N° publication PCT/PCT Publication No.:** 2022/167966
(30) **Priorité/Priority:** 2021/02/05 (IT102021000002570)

(51) **Cl.Int./Int.Cl. F24C 15/20** (2006.01)
(71) **Demandeur/Applicant:**
ELICA S.P.A, IT
(72) **Inventeurs/Inventors:**
BARIVIERA, DIEGO, IT;
BORGIANI, LORENZO, IT;
CRISA, FABRIZIO, IT
(74) **Agent:** TAKAGAWA, DAVID H.

(54) **Titre : APPAREIL DE CUISSON D'ALIMENTS**
(54) **Title: APPARATUS FOR COOKING FOOD**

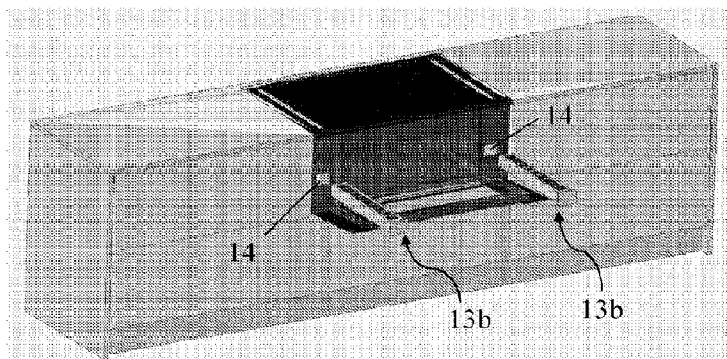

Fig. 6b

(57) **Abrégé/Abstract:**

The present invention relates to an apparatus (1) for cooking food comprising: an oven (2) having a cavity (3) and a door (4) associated to a front surface (3 A) of the cavity (3) and configured to selectively provide access to the inside of the cavity (3); a hob (6) defining an upper surface (1 A) of the cooking apparatus (1) comprising at least one heating element (7); at least one inlet opening (8) provided in said upper surface (1 A); at least one outlet opening (9); a downdraft hood (10) having at least one suction unit (11) configured to suck cooking fumes through said at least one inlet opening (8) and to eject them through said outlet opening (9); a duct system (12) comprising a first path of cooking fumes (12a) such that the sucked fumes flow between the inlet opening (8) and the outlet opening (9); a filter (13) arranged in the first path of cooking fumes (12a) upstream of the suction unit to filter the sucked cooking fumes. A characteristic of the apparatus (1) is that it comprises an extraction/insertion opening (14) provided in said front surface (3 A) of the cavity (3) of said oven (2), said extraction/insertion opening (14) being configured to extract/insert said filter (13), said extraction/insertion opening (14) being accessible when said door (4) allows access to the inside of the cavity (3) of the oven (2).

Date Submitted: 2023/07/28

CA App. No.: 3206957

Abstract:

The present invention relates to an apparatus (1) for cooking food comprising: an oven (2) having a cavity (3) and a door (4) associated to a front surface (3 A) of the cavity (3) and configured to selectively provide access to the inside of the cavity (3); a hob (6) defining an upper surface (1 A) of the cooking apparatus (1) comprising at least one heating element (7); at least one inlet opening (8) provided in said upper surface (1 A); at least one outlet opening (9); a downdraft hood (10) having at least one suction unit (11) configured to suck cooking fumes through said at least one inlet opening (8) and to eject them through said outlet opening (9); a duct system (12) comprising a first path of cooking fumes (12a) such that the sucked fumes flow between the inlet opening (8) and the outlet opening (9); a filter (13) arranged in the first path of cooking fumes (12a) upstream of the suction unit to filter the sucked cooking fumes. A characteristic of the apparatus (1) is that it comprises an extraction/insertion opening (14) provided in said front surface (3 A) of the cavity (3) of said oven (2), said extraction/insertion opening (14) being configured to extract/insert said filter (13), said extraction/insertion opening (14) being accessible when said door (4) allows access to the inside of the cavity (3) of the oven (2).

Title: "Apparatus for cooking food".**DESCRIPTION***Technical Field*

5 The present invention relates to an apparatus for cooking food, in accordance with the preamble of claim 1.

In particular, the present invention relates to an apparatus for cooking food which integrates an oven, a hob and a hood of the type commercially known as a recessed or downdraft hood.

Background art

10 In the state of the art there are known apparatuses for cooking food comprising an oven, a hob and a hood for sucking cooking fumes.

In particular, some of such apparatuses have downdraft hoods integrated in the hob or alternatively in the top of a kitchen cabinet where the apparatus for cooking food is housed.

15 Such a downdraft hood is configured to generate a descending current greater than the ascending speed of the fumes due to cooking so that such fumes are sucked towards an opening provided in the hob itself with motion having a downwards direction.

For example, document US 6,455,818 B1 shows an apparatus for cooking food
20 comprising an oven and a hob arranged vertically above the oven.

Such a hob has a central opening arranged between a plurality of cooking zones and is in fluid communication with a suction unit, positioned below the hob. In use, the suction unit is configured to generate a negative pressure which results in a suction effect of the cooking fumes through the central slot.

25 Said apparatus for cooking food comprises a filter unit arranged in the slot and vertically removable from the hob to carry out filter cleaning and replacing operations.

Disadvantageously, such a filter unit extends vertically between the hob and the oven thus reducing the useful volume of the cooking chamber of the oven itself.

30 In other words, the filter unit extending vertically between the hob and the oven prevents making oven cooking chambers which extend vertically up to near the hob. This limits the usability of the oven by the user.

Furthermore, the inlet opening of the fumes, being arranged in a central portion

of the hob, reduces the useful surface area thereof usable for cooking food. This reduction of the useful surface cooking area is all the more disadvantageous if the hob is of the "free induction" type, i.e., if the entire surface of the hob can be used for cooking food.

5 *Object of the invention*

In this context, an object underlying the present invention is to provide an apparatus for cooking food capable of maximising the useful volume and surface area for cooking food.

SUMMARY OF THE INVENTION

10 In accordance with the present invention, the technical task indicated and the specified objects are achieved by an apparatus for cooking food in accordance with one or more of the claims below.

Advantages of the invention

15 Thanks to the present invention, it is possible to provide an apparatus for cooking food having an oven cavity which, with the same installation conditions, allows to maximise the useful volume of the oven's cooking chamber. In particular, this is all the more advantageous if the apparatus of the present invention is installed in a modular cabinet of a kitchen having standard dimensions. In fact, in this configuration, thanks to the present invention it is possible to dedicate only a part of the available
20 space of the cabinet to the apparatus for cooking food in accordance with the present invention while preserving the other parts both in terms of intended use and functionality.

Furthermore, thanks to the present invention it is possible to obtain an apparatus for cooking food having a greater useful surface area for positioning the containers
25 containing the food to be heated.

Furthermore, thanks to the present invention, the maintenance operations of the filters are easier.

BRIEF DESCRIPTION OF THE DRAWINGS

30 Further features and advantages of the present invention will become more apparent from the description of an exemplary, but not exclusive, and therefore non-limiting preferred embodiment of an apparatus for cooking food, as illustrated in the appended figures, in which:

- figure 1a shows a perspective view from the front of an apparatus for cooking food, in accordance with the present invention, when the apparatus for cooking food is depicted in a first configuration of use and installed in a modular kitchen cabinet;
- figure 1b shows a perspective view of the apparatus for cooking food of figure 1a, where said apparatus for cooking food is depicted in a second configuration of use;
- figure 2 shows a perspective section view from the side of the apparatus for cooking food of figure 1a;
- figure 3 shows a perspective view from the back of some components of the apparatus for cooking food of figure 1a;
- figure 4 shows a perspective view from the back of figure 3 some parts of which have been removed to better illustrate others;
- figure 5 shows a perspective view from the front of some components of the apparatus for cooking food of figure 1a;
- figure 6a shows a perspective view from the side of a component of the apparatus for cooking food of figure 1a;
- figure 6b shows how the component of figure 6a is inserted in the apparatus of figure 1a.

DETAILED DESCRIPTION

Even if not explicitly highlighted, the individual features described with reference to the specific embodiments shall be understood as accessory to and/or interchangeable with other features described with reference to other embodiments.

The present invention relates to an apparatus for cooking food, indicated by 1 in the accompanying figures

In particular, the cooking apparatus 1 object of the present invention is configured to be recessed inside a special compartment 101 of a kitchen cabinet 100 having standard dimensions.

For example, in an embodiment, the compartment can have a height of 360mm, a width of 900mm, and a depth which varies as a function of the specific applications.

Preferably, the kitchen cabinet envisages that its compartments are occupied by drawers 103, for example 360mm tall, arranged on opposite sides of the compartment 101, and a lower drawer 104 arranged vertically below the compartment 101.

In other words, the kitchen cabinet 100 includes the apparatus for cooking food

1 which occupies a compartment of the cabinet 100.

As shown in figures 1a and 1b, such an apparatus 1 for cooking food comprises an oven 2 having a cavity 3 and a door 4 associated to a front surface 3A of the cavity.

The cavity 3 is configured to accommodate one or more foods to bake therein.

5 In an embodiment of the present invention, and in particular if the apparatus 1 for cooking food is integrated in the kitchen cabinet 100, it is understood that the cavity 3 of the oven 2 has a width equal to 660mm, a height equal to 210mm and a depth equal to 405mm.

The door 4 is configured to selectively provide access inside the cavity 3 of the oven 2 so as to allow the food to be cooked to be loaded and the cooked food to be unloaded.

In detail, such a door 4 is constrained in rotation to the apparatus 1 so as to be able to switch it between a first configuration of use, for example of cooking, in which the door 4 closes the cavity 3 frontally, and a second configuration of use, for example of loading/unloading food, in which the cavity 3 is frontally accessible.

15 The food loading/unloading configuration will also be indicated hereinafter as a maintenance configuration, as it allows the ordinary maintenance operations to be carried out on some components of the apparatus 1. More details on this will be provided later in the description.

20 The above-mentioned cooking and loading/unloading (or maintenance) configurations are shown in figures 1a and 1b, respectively.

The apparatus 1 of the present invention further comprises a hob 6 having a predetermined width "L", length "l" and height "H.

25 Such a hob 6 defines an upper surface 1A, which limits the apparatus 6 above, and a lower surface 1B, opposite the upper surface 1A.

In particular, when the apparatus 1 is installed in the special compartment 101 of the standard-sized kitchen cabinet 100, the upper surface 1A represents the visible or in-view side for the user while the lower surface 1B represents the surface hidden from the user's view, for example because it is recessed.

30 Preferably, when the apparatus 1 is installed the surface 1A is arranged seamlessly (i.e., continuously, uninterruptedly) with an outer surface 102A of a top 102 of the kitchen cabinet 100, as shown in figure 2 and in figure 1a.

The hob 6 comprises at least one heating element 7 at which a container containing the food to be heated is available.

Preferably, the hob 6 comprises a plurality of heating elements 7 suitably distributed on the upper surface 1A and, in particular, capable of transmitting energy
5 to the bottom of the containers in which the food to be heated is kept.

In a preferred embodiment, the at least one heating element 7 is embodied in a resistive, or gas or, preferably, inductive heating element.

Furthermore, the plurality of heating elements can be distributed on the upper surface 1A by means of a plurality of micro-inductors homogeneously distributed
10 throughout the entire hob 6.

Typically, the upper surface 1A is embodied in a sheet of glass or material having similar properties.

The apparatus 1 of the present invention further comprises at least one inlet opening 8 on the upper surface 1A of the hob 6.

In detail, the inlet opening 8 extends between the upper surface 1A and the lower surface 1B through the entire height "H" of the hob 6. The inlet opening 8 thus takes
15 the form of a through hole in the hob 6.

Preferably, the inlet opening 8 is rectangular in shape and one of its two dimensions is much larger with respect to the other. Preferably its smaller dimension
20 is between 2 - 3.5 cm.

Preferably, as shown in figure 3, the apparatus 1 comprises two or more inlet openings 8 each of which is arranged near a respective perimeter edge P of the hob 6.

In greater detail, the perimeter edge P comprises two side edges PL, which extend along the length "l" of the hob 6, a front edge PA extending along the width
25 "L" of the hob 6 at the oven door 4, and a rear edge PP extending along the width "L" of the hob 6 opposite the front edge.

It should be specified that the inlet openings can extend along the length "l" of the hob at both side edges, and along the width "L" only at the rear edge.

The apparatus 1 further comprises an outlet opening 9 in fluid communication
30 with the at least one inlet opening 8.

Such an outlet opening 9 represents the ejection point of the sucked fumes.

As shown in figure 4, the apparatus 1 comprises a downdraft-type hood 10.

Preferably, the downdraft-type hood 10 can be operated in suction or filtering mode. In greater detail, in suction mode the hood 10 is configured to eject the cooking fumes in an environment outside the room in which the hood 10 is arranged, preferably an open environment, while in filtering mode the hood 10 ejects the cooking fumes inside the room in which the hood 10 is arranged.

Such a downdraft hood 10 has one or more suction units 11 each of which is configured to suck the cooking fumes through the at least one inlet opening 8 and to eject them through a respective outlet opening 9.

The suction unit 11 is configured to generate a negative pressure (less than atmospheric) responsible for the suction effect of the cooking fumes through the at least one inlet opening 8.

Preferably, the suction unit 11 comprises a conveyor 11a adapted to channel the cooking fumes.

Preferably, as shown in figures 3 and 4, the apparatus 1 object of the present invention comprises a suction chamber 16 inside which the suction unit is arranged. Even more preferably, said suction chamber 16 contains the conveyor 11a entirely therein.

Even more preferably, said suction chamber 16 comprises a bottom 16a shaped to collect fluids such as water/grease flowing from the inlet opening 8. For example, the bottom can comprise a liquid collection basin (not shown) which can be removed from the suction chamber 16, or it can have a drainage tap (not shown) accessible by a user and arranged at a liquid collection cavity so as to allow the liquid accumulated therein to be emptied.

It should be specified that to fulfil the function of collecting the fluids, the bottom must prevent them from flowing out of the outlet opening 9 or from the openings if there are two suction units 11. To this end, a rib of predetermined height projecting from the bottom of the suction chamber 16 is included, which extends between the rear and front edge of the chamber itself along a direction perpendicular to both edges.

As shown in figures 3 and 4, the apparatus 1 comprises a duct system 12 comprising a first path of cooking fumes 12a. The sucked cooking fumes flowing along the first path of cooking fumes 12a flow between the at least one inlet opening 8 and the outlet opening 9.

In other words, the first path of cooking fumes 12a fluid-dynamically connects the inlet opening 8 and the outlet opening 9.

According to an aspect the duct system 12 is made of metallic material to better resist the heat emanating from the cavity 3 of the oven 2 during its operation. However,
5 other suitable materials can be used instead of metallic.

If the present invention comprises two inlet openings extending at the side edges PL of the hob 6, the duct system 12 comprises a path of the cooking fumes for each inlet opening 8. That is, the duct system 12 comprises a first and a second path of cooking fumes 12a, 12b each of which is associated to a respective inlet opening but
10 with the same outlet opening.

In this case in which the present invention comprises two inlet openings 8, the first and second paths of cooking fumes 12a, 12b are in fluid communication with the suction chamber upstream of the suction unit 11.

If the present invention comprises one or two further inlet openings 8 at the rear
15 edge PP of the hob 6, in addition to the two inlet openings 8 extending at the side edges PL, said duct system 12 comprises a third and a fourth path of cooking fumes 12c, 12d respectively in fluid communication with the first and second path 12a, 12b. Such third and fourth paths of cooking fumes 12c, 12d are configured to conduct the sucked cooking fumes through the further inlet openings 8 to the outlet opening, through the
20 first and second path of cooking fumes 12a, 12b.

As shown in figure 5, the apparatus 1 comprises a filter 13 for filtering the sucked cooking fumes.

Such a filter 13 is arranged in the first path of cooking fumes 12a of the duct system 12, in particular upstream of the suction unit 11.

Therefore, in use, the cooking fumes, once sucked through the at least one inlet
25 opening 8 by the suction effect generated by the suction unit 11, then proceed along the first path of cooking fumes 12a passing through the filter 13 to thus reach the suction unit 11 and then the outlet opening 9.

It should be specified that if there are two inlet openings extending at the side
30 edges PL, the second path of cooking fumes 12b comprises a respective filter 13 adapted to filter the cooking fumes flowing between the respective inlet openings 8 and the outlet opening 9. Therefore, in this case part of the cooking fumes will flow

along the first path 12a and part along the second path 12b to then reach the suction unit 11 and then the outlet opening 9

What is said for the first path of cooking fumes 12a below will be equally valid for the second path of cooking fumes 12b in the case in which the invention comprises
5 two inlet openings 8 extending at the side edges PL.

If the third and fourth paths of cooking fumes 12c, 12d are present, they are connected to the first and second paths of cooking fumes 12a, 12b upstream of the respective filters 13, respectively.

As shown in the sectional view of the first path of figure 5, the duct 12 in which
10 the filter is arranged is shaped to create a shape coupling with such a filter.

Preferably, the filter comprises a grease filter 13a configured to filter the greases present in the cooking fumes.

Still more preferably, the grease filter and is arranged transversely to a main extension direction Y-Y of the first path of cooking fumes 12a so as to maximise the
15 surface of the grease filter 13a exposed to the cooking fumes flow.

It should be specified that the grease filter is arranged in the duct so as to occupy the entire section, so that the entire flow is filtered.

For example, the grease filter 12a is made of a metal grille (or other material having similar features) retained by a metal or plastic profile arranged peripherally to
20 the grille.

Still more preferably, the filter 13 comprises an odour filter 13b configured to filter the molecules responsible for the odours of the cooking fumes, eliminating them.

In detail, as shown in figure 5, said odour filter 13b is arranged downstream of the grease filter 13a, i.e., the flow of cooking fumes passes first through the grease
25 filter 13a and then through the odour filter 13b.

It should be specified that the odour filter 13b as well as the grease filter 13a is arranged in the duct so as to occupy the entire section thereof, so that the entire flow is filtered.

According to an aspect, the odour filter 13b comprises a set of filters housed in
30 respective cavities of a filter holder element 131 extending along a main extension direction A-A.

For example, the odour filter 13b is an activated carbon filter.

In an embodiment the grease filter 13a and the odour filter 13b are constrained together so as to be removable/insertable as a single filter.

In the embodiment shown in the accompanying figures, the grease filter 13a is separate and distinct from the odour filter 13b, i.e., each grease and odour filter is
5 removable/insertable independently of the other, i.e., they are individually movable.

As certainly known to those skilled in the art, the suction hood filters of cooking fumes require ordinary maintenance operations which typically involve the cleaning/replacement of filters.

It is therefore evident that the user needs to be able to access the filter 13 in order
10 to carry out such routine maintenance operations.

In greater detail, as shown in Figure 1b, the apparatus 1 comprises an extraction/insertion opening 14 configured to allow the extraction and insertion of the filter 13 inside the first path of cooking fumes 12a.

In particular, the extraction/insertion opening 14 is sized to allow the extraction
15 and insertion of the filter 13 inside the first path of cooking fumes 12a.

Such an extraction/insertion opening 14 is arranged on the front surface 3A of the cavity 3 of the oven 2, and the filter 13 is removable/insertable along a direction perpendicular to said front surface 3A.

It should be noted that such filter extraction/insertion operations 13 can only be
20 carried out when the door 4 allows access to the oven cavity, i.e., when it is in the maintenance configuration. In fact, as shown in figure 1a, when the door 4 is in the cooking configuration, the extraction/insertion opening 14 is inaccessible, as it is covered by the door itself.

Preferably, this extraction/insertion opening 14 is arranged laterally with respect
25 to a perimeter contour F which surrounds an access mouth to the cavity 3 of the oven 2 on the front surface 3A.

Even more preferably, said extraction/insertion opening 14 is rectangular in shape and extends along a vertical direction at the filter 13, so as to allow the user to move the filter to and from the duct of the first path of fumes 12a.

The extraction/insertion opening 14 can extend along the vertical direction Y-Y
30 at both the grease filter 13a and the odour filter 13b, so as to allow the user to grasp and move them both or individually to and from the duct 12 in which they are housed.

In this case the opening 14 defines a surface, for example equal to 65x190mm.

In a preferred embodiment, the extraction/insertion opening 14 extends along the vertical direction Y-Y only at the odour filter 13b so as to extract only the odour filter.

In this case the opening 14 defines a surface, for example equal to 65x50mm.

5 It should be noted that if the extraction/insertion opening 14 extends along the vertical direction Y-Y only at the odour filter 13b, then it is possible for the grease filter 13a to be extracted from the inlet opening 8 along a direction perpendicular to the hob, i.e., substantially parallel to the vertical direction Y-Y.

Preferably, the apparatus 1 object of the present invention comprises closing
10 means 15 associated to the extraction/insertion opening 14 to tightly close it.

In other words, in use, the closing means 15 are shaped to hermetically plug the extraction/insertion opening 14 so as to prevent the creation of an air flow through the extraction/insertion opening 14, at least when the door 4 of the oven 2 is in the cooking configuration.

15 It should be noted that the closing means 15 have a surface which must be at least equal to or greater than that of the extraction/insertion opening 14.

In a first embodiment of the present invention, the closing means 15 are associated to the door 4 of the oven 2.

In detail, the oven door 4 comprises a surface adapted to close the
20 extraction/insertion opening 14 when the door 4 closes the cavity 3 of the oven 2, i.e., when the apparatus is in the cooking mode.

In other words, in the first embodiment, the extraction/insertion opening 14 is closed by switching the oven door 4 from the food loading/unloading configuration to the cooking configuration.

25 It should be specified that if both the first and second path for sucking fumes 12a, 12b are present, there will be two extraction/insertion openings 14 which will be closed simultaneously when the door 4 closes the cavity 3 of the oven 2.

In a second embodiment of the present invention, the closing means 15 are associated to the front surface 3A by pressure or hinging.

30 In other words, in the second embodiment, the closing means 15 are a sort of 'cap' which snaps into the front surface 3A to close the extraction/insertion opening 14.

In this embodiment, the closing means 15 can be hinged to the front surface 3A, so that by rotating with respect to the front surface they are arranged at the extraction/insertion opening 14 to close it.

5 In a third embodiment of the present invention, the closing means 15 are associated to a head end 130 of the filter 13 which, abutting against the extraction/insertion opening 14, when the filter is housed in the duct 12, is able to completely close it.

10 It should be specified that, in this scenario, both the odour filter 13b and the grease filter 13a comprise a relative closing surface arranged at a head end adapted to close the extraction/insertion opening 14, when the filter 13 is housed in the duct 12.

In a preferred embodiment, as shown in figures 6a and 6b, the closing means 15 comprise a closing surface 131a arranged at the head end 130 of the odour filter 13b only.

15 Such a head end 130 is oriented transversely, preferably orthogonally, to the main extension direction A-A of the filter holder 131.

In such a preferred embodiment, the relative closing surface 131a arranged at a head end 130 of the odour filter 13b is adapted to close the extraction/insertion opening 14, when the filter 13b is housed in the duct 12.

20 In other words, in the aforementioned preferred embodiment, the closing means 15 are associated only with the head end 130 of the odour filter 13b while the grease filter 13a lacks them.

25 Therefore, again in the aforementioned preferred embodiment, the odour filter 13b, by means of the relative closing surface 131a arranged at a head end 130, plugs the opening 14 and is removable/insertable through such an opening 14 while the grease filter 13 is removable/insertable from the respective inlet opening 8 (in the case of two or more inlet openings).

30 Clearly, in order to satisfy contingent and specific needs, a person skilled in the art may make numerous modifications and variants to the configurations described above. Such modifications and variations are all also contained within the scope of the invention, as defined by the following claims.

CLAIMS

1. An apparatus (1) for cooking food comprising:

- an oven (2) having a cavity (3) and a door (4) associated to a front surface (3A) of the cavity (3) and said door (4) being configured to selectively provide access to the
5 inside of the cavity (3) of the oven (2);
 - a hob (6) comprising at least a heating element (7), the hob (6) defining an upper surface (1A) of the cooking apparatus (1);
 - at least an inlet opening (8) provided in said upper surface (1A) of the hob (6);
 - at least an outlet opening (9);
 - 10 - a downdraft hood (10) having at least a suction unit (11) configured to suck cooking fumes through said at least an inlet opening (8) and to eject them through said outlet opening (9);
 - a duct system (12) comprising a first path of cooking fumes (12a) such that the sucked fumes flow between the inlet opening (8) and the outlet opening (9);
 - 15 - a filter (13) for filtering the sucked cooking fumes, said filter (13) being arranged in said first path of cooking fumes (12a), said filter (13) being arranged upstream of said suction unit (11);
- characterised in that** it comprises an extraction/insertion opening (14) provided in said front surface (3A) of the cavity (3) of said oven (2), said extraction/insertion
20 opening (14) being sized so as to extract/insert said filter (13), said extraction/insertion opening (14) being accessible when said door (4) allows access to the inside of the cavity (3) of the oven (2).

2. An apparatus (1) for cooking food according to claim 1, characterised in that it
25 comprises closing means (15) associated to said extraction/insertion opening (14) to tightly close said extraction/insertion opening (14).

3. An apparatus (1) for cooking food according to claim 1 or 2, wherein said filter (13)
30 comprises a grease filter (13a).

4. An apparatus (1) for cooking food according to claim 3, wherein said filter (13)
comprises an odour filter (13b), said odour filter (13b) being arranged downstream of

said grease filter (13a).

- 5 **5.** An apparatus (1) for cooking food according to claim 1, comprising two or more inlet openings (8) each of which is arranged near a respective perimeter edge (P) of the hob (6).
- 6.** An apparatus (1) for cooking food according to claim 2, wherein said closing means (15) are associated to said door (4) of the oven (2).
- 10 **7.** An apparatus (1) for cooking food according to claim 2, wherein said closing means (15) are associated to said front surface (3A) by means of pressure or hinging.
- 8.** An apparatus (1) for cooking food according to claim 2, wherein the filter (13) comprises a head end (130) adapted to abut against the extraction/insertion opening
15 (14) to close it when the filter 13 is inserted in the duct;
- 9.** An apparatus (1) for cooking food according to claim 1, comprising a suction chamber (16) inside which the suction unit (11) is arranged.
- 20 **10.** An apparatus (1) for cooking food according to claim 5, wherein said duct system (12) comprises a second path of cooking fumes (12b) so that the sucked fumes flow between a respective inlet opening (8) and said outlet opening (9).
- 11.** An apparatus (1) for cooking food according to claim 10, wherein the second path
25 of cooking fumes (12b) comprises a respective filter (13) adapted to filter the cooking fumes flowing between the respective inlet opening (8) and said outlet opening (9).
- 12.** An apparatus (1) for cooking food according to claim 10 or 11, wherein the first
30 and second path of cooking fumes (12a, 12b) are in fluid communication with said suction chamber (16) upstream of said suction unit (11).
- 13.** An apparatus (1) for cooking food according to claim 11, wherein said duct system

(12) comprises a third and fourth path of cooking fumes (12c, 12d) respectively in fluid communication with the first and second path of cooking fumes (12a, 12b) upstream of the respective filter (13).

- 5 **14.** An apparatus (1) for cooking food according to claim 9, wherein the suction chamber (16) comprises a bottom (16a) adapted to collect water/grease flowing through said at least an inlet opening (8).

10

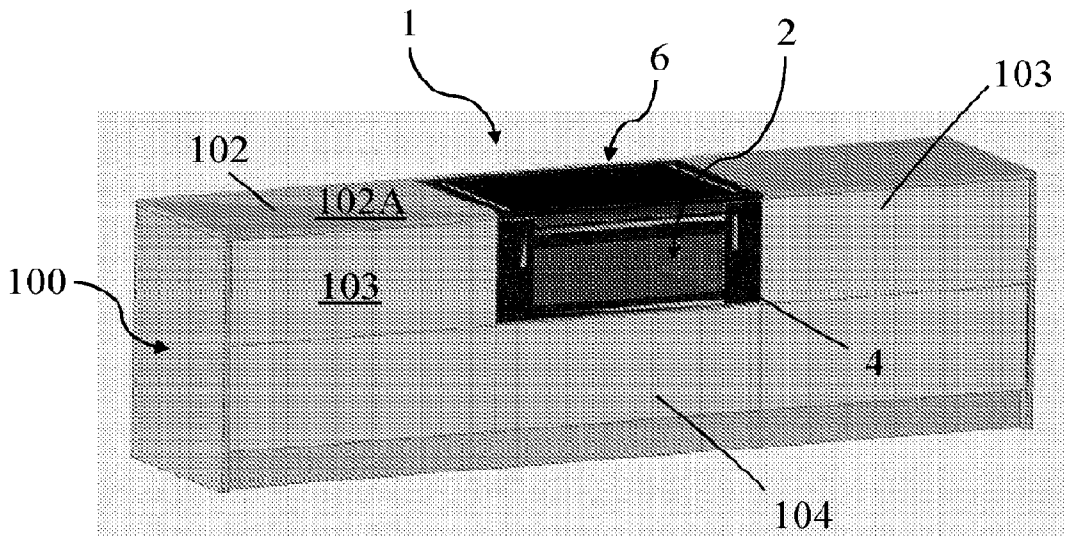

Fig. 1a

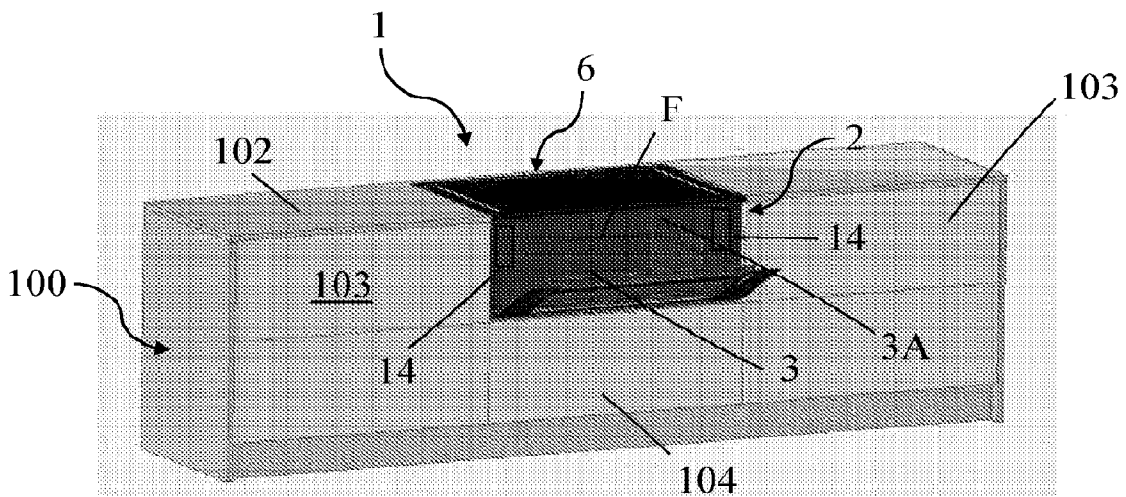

Fig. 1b

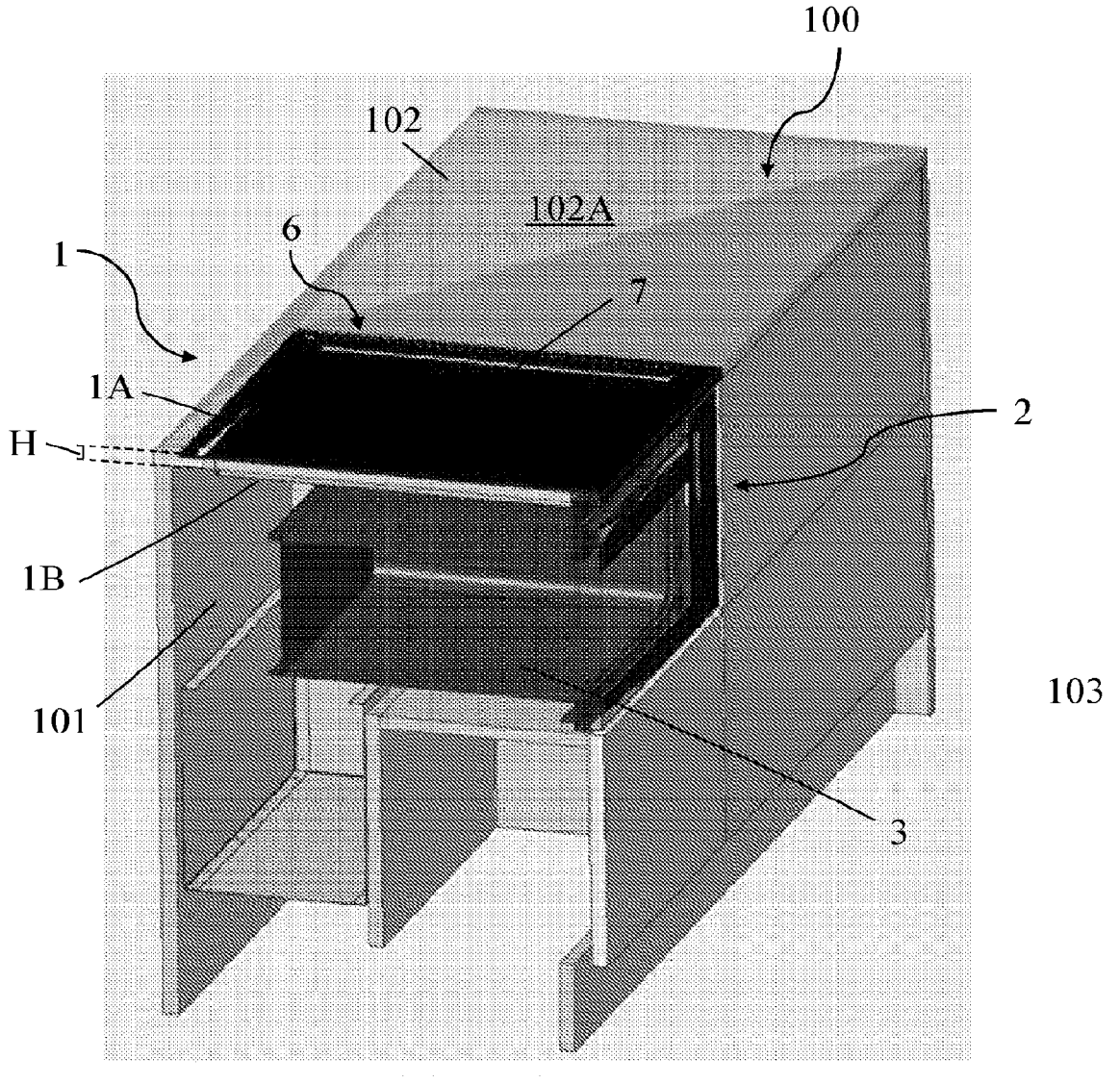

Fig. 2

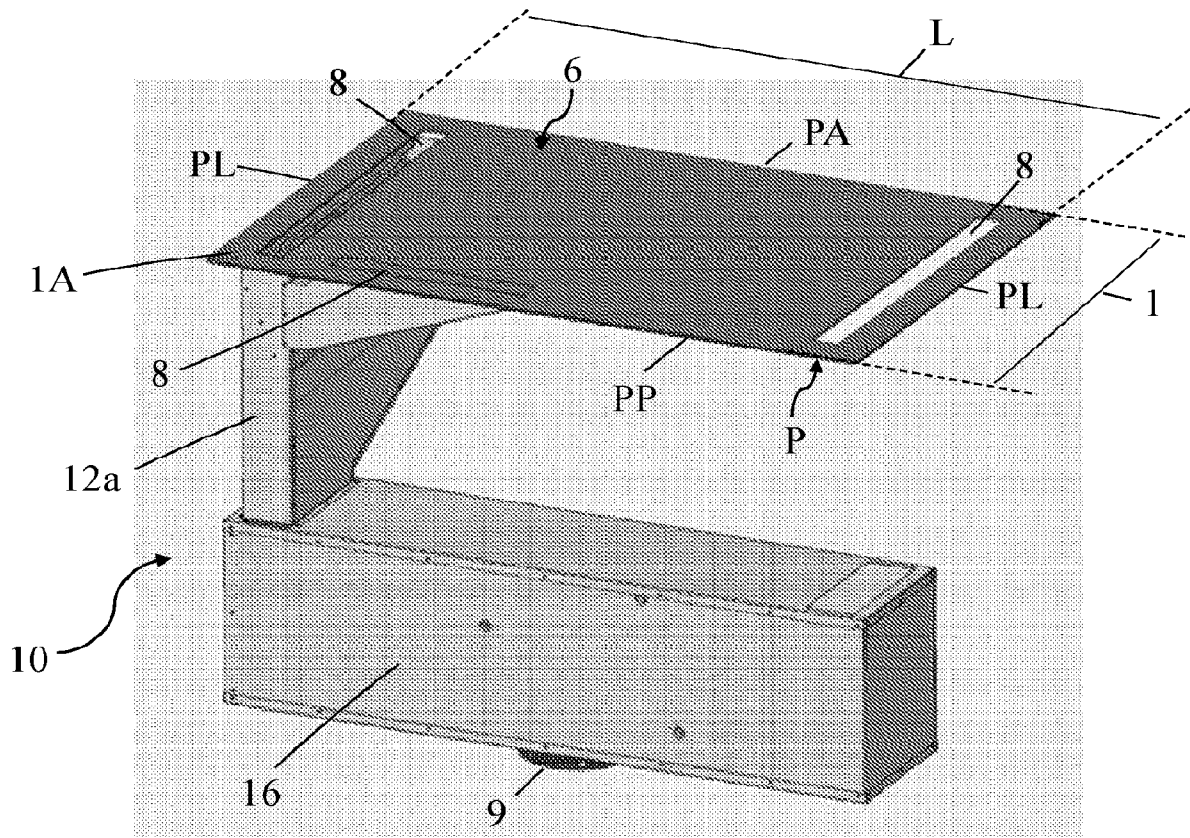

Fig. 3

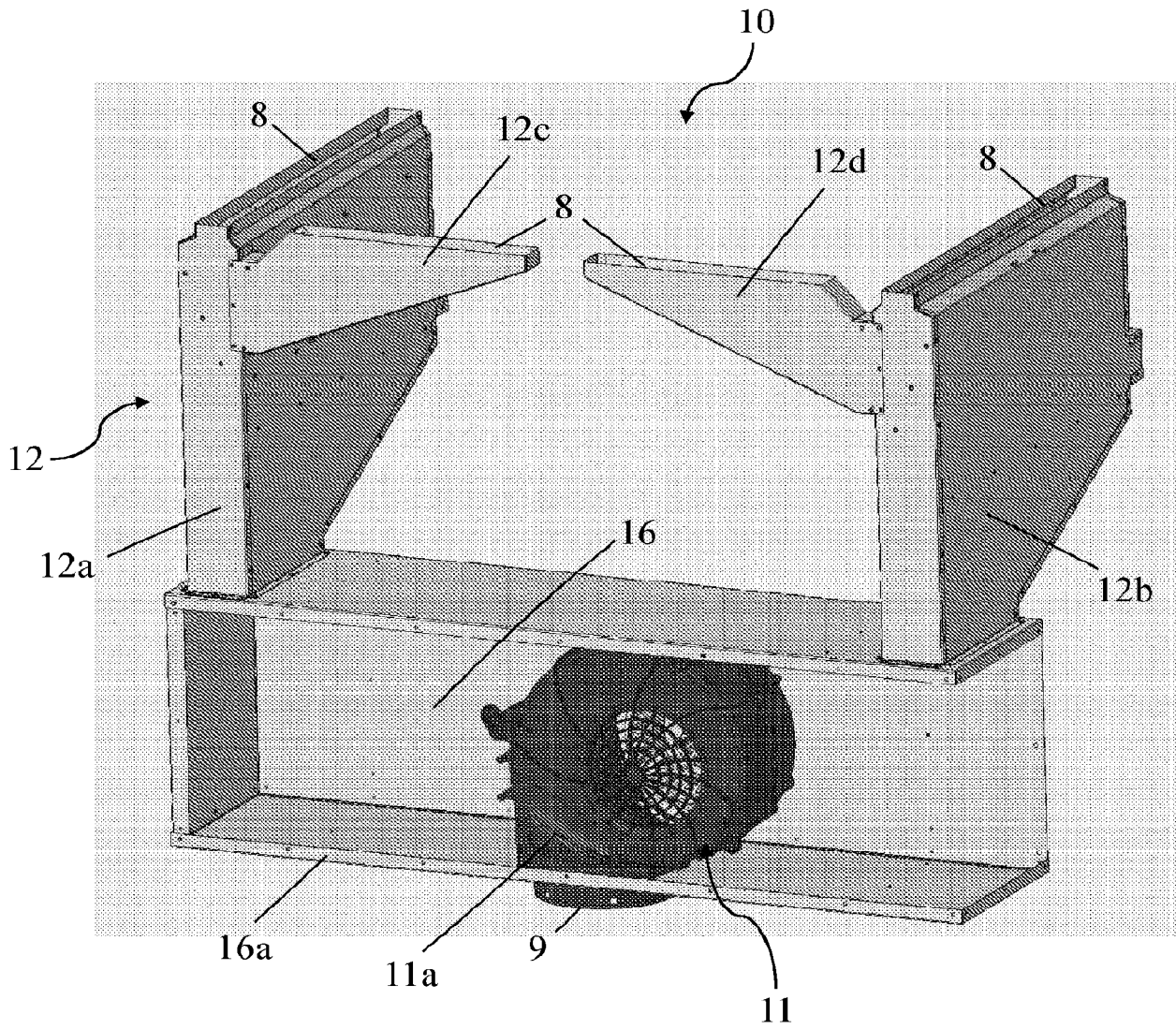

Fig. 4

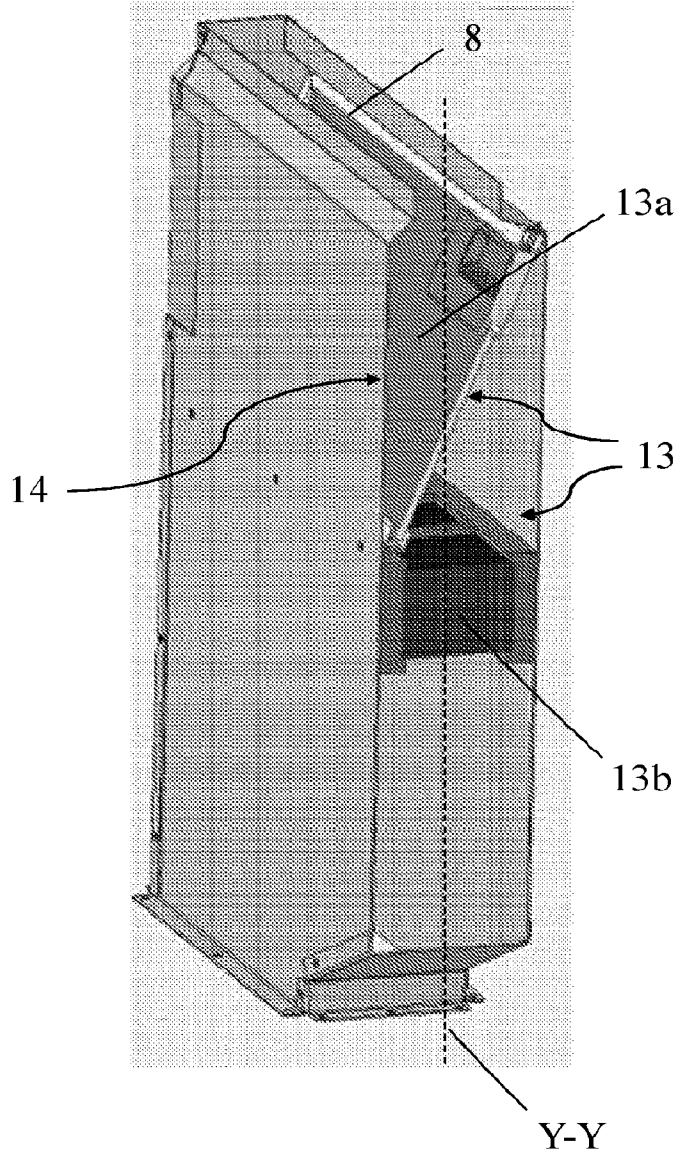

Fig. 5

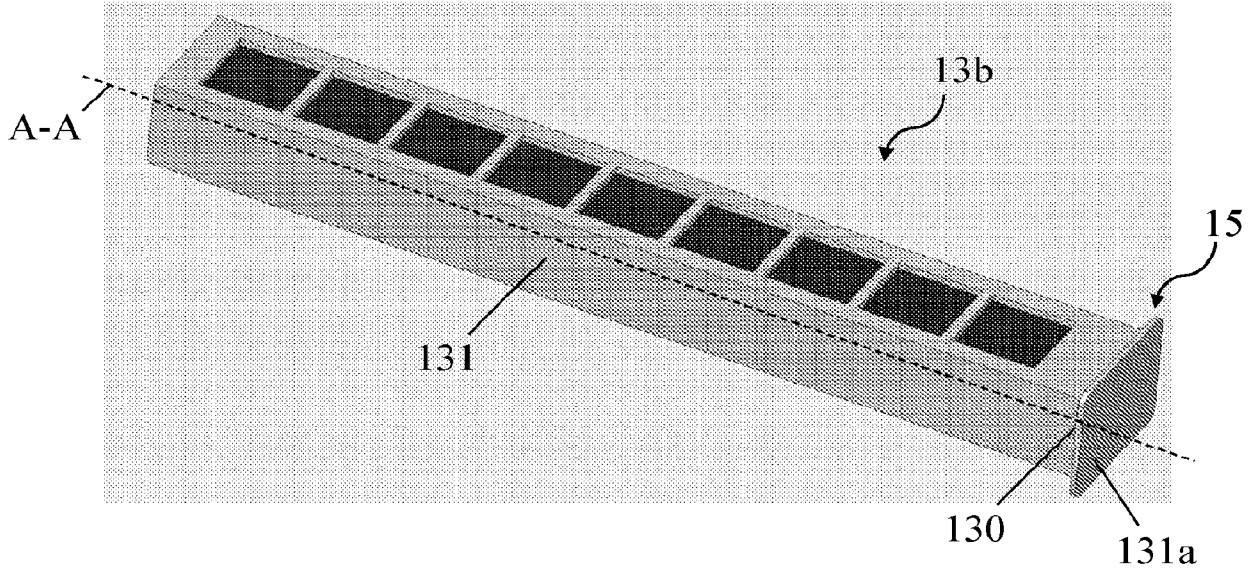

Fig. 6a

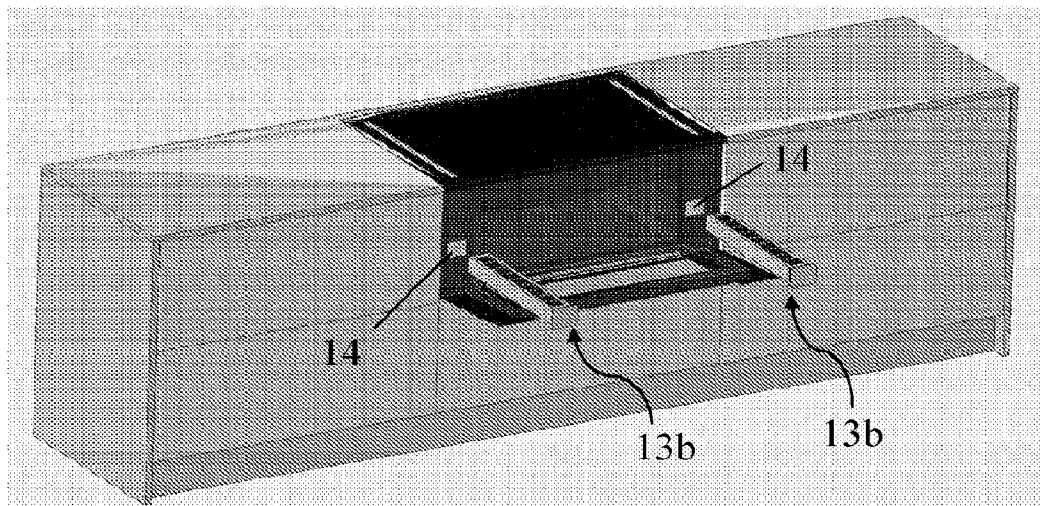

Fig. 6b

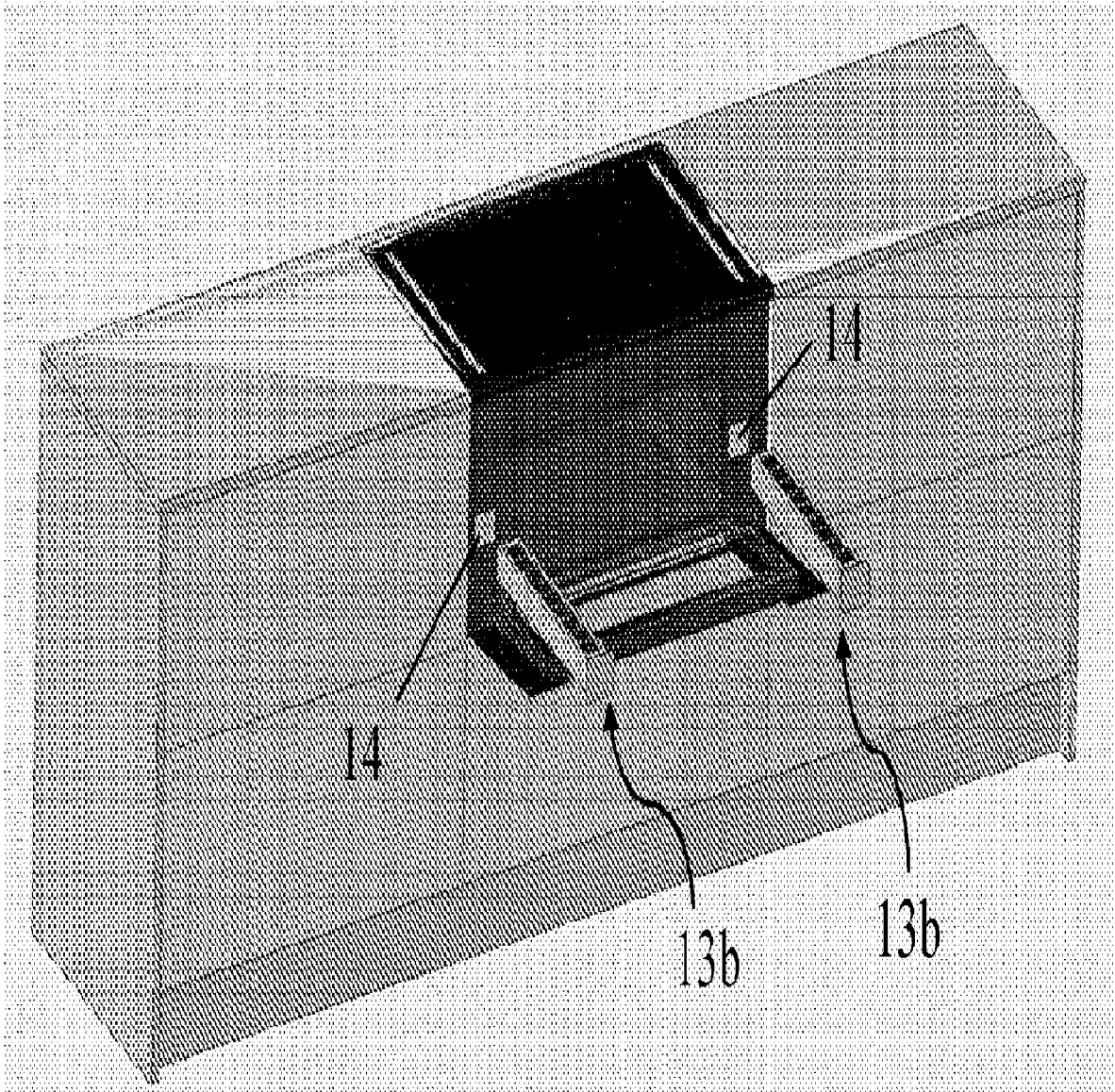

Fig. 6b