



US00D556836S

(12) **United States Design Patent**
Ashida et al.

(10) **Patent No.:** **US D556,836 S**

(45) **Date of Patent:** **** Dec. 4, 2007**

(54) **ELECTRONIC GAME MACHINE
SUPPORTED ON A BASE STAND**

(75) Inventors: **Kenichiro Ashida**, Kyoto (JP); **Masato Ibuki**, Kyoto (JP); **Shinji Yamamoto**, Kyoto (JP); **Hirokazu Matsui**, Kyoto (JP); **Akiko Suga**, Kyoto (JP)

(73) Assignee: **Nintendo Co., Ltd.**, Kyoto (JP)

(**) Term: **14 Years**

(21) Appl. No.: **29/271,595**

(22) Filed: **Jan. 23, 2007**

Related U.S. Application Data

(62) Division of application No. 29/242,325, filed on Nov. 9, 2005.

(30) **Foreign Application Priority Data**

May 11, 2005 (JP) 2005-13455
May 11, 2005 (JP) 2005-13456
May 11, 2005 (JP) 2005-13469

(51) **LOC (8) Cl.** **21-01**

(52) **U.S. Cl.** **D21/332; D21/324**

(58) **Field of Classification Search** D21/332,
D21/333, 324; 273/148 B, 148 R; 463/43-47,
463/29-35, 1; D14/496, 483, 475, 477; 345/156-169
See application file for complete search history.

(56) **References Cited**

U.S. PATENT DOCUMENTS

D379,832 S 6/1997 Ashida
D407,761 S 4/1999 Barr
D412,940 S * 8/1999 Kato et al. D21/324
D419,199 S 1/2000 Cordell et al.

D419,200 S 1/2000 Ashida
D433,381 S * 11/2000 Talesfore D13/123
D460,787 S * 7/2002 Nishikawa D21/329
6,540,611 B1 * 4/2003 Nagata 463/31
6,565,444 B2 * 5/2003 Nagata et al. 463/46
6,743,104 B1 * 6/2004 Ota et al. 463/44
D495,336 S * 8/2004 Andre et al. D14/434
6,821,204 B2 * 11/2004 Aonuma et al. 463/32
6,955,606 B2 * 10/2005 Taho et al. 463/43
7,090,582 B2 * 8/2006 Danieli et al. 463/35
D531,228 S * 10/2006 Ashida et al. D21/332
7,155,604 B2 * 12/2006 Kawai 713/2
D543,246 S * 5/2007 Ashida et al. D21/333

* cited by examiner

Primary Examiner—Prabhakar Deshmukh

(74) *Attorney, Agent, or Firm*—Nixon & Vanderhye, PC

(57) **CLAIM**

The ornamental design for an electronic game machine supported on a base stand, as shown and described.

DESCRIPTION

FIG. 1 is a front, top and left perspective view of an electronic game machine supported on a base stand showing our new design;

FIG. 2 is a rear, bottom and right perspective view thereof;

FIG. 3 is a front view thereof;

FIG. 4 is a rear view thereof;

FIG. 5 is a left side view thereof;

FIG. 6 is a right side view thereof;

FIG. 7 is a top plan view thereof; and,

FIG. 8 is a bottom plan view thereof.

1 Claim, 5 Drawing Sheets

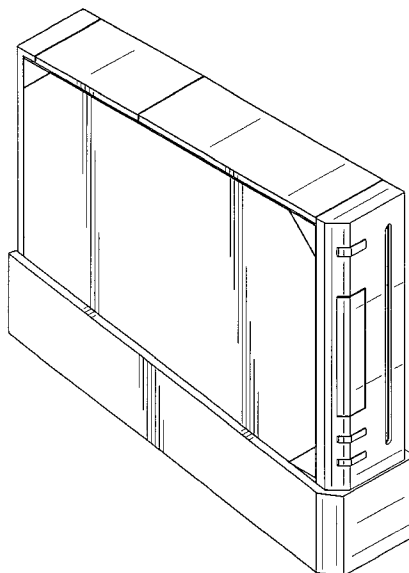

FIG. 1

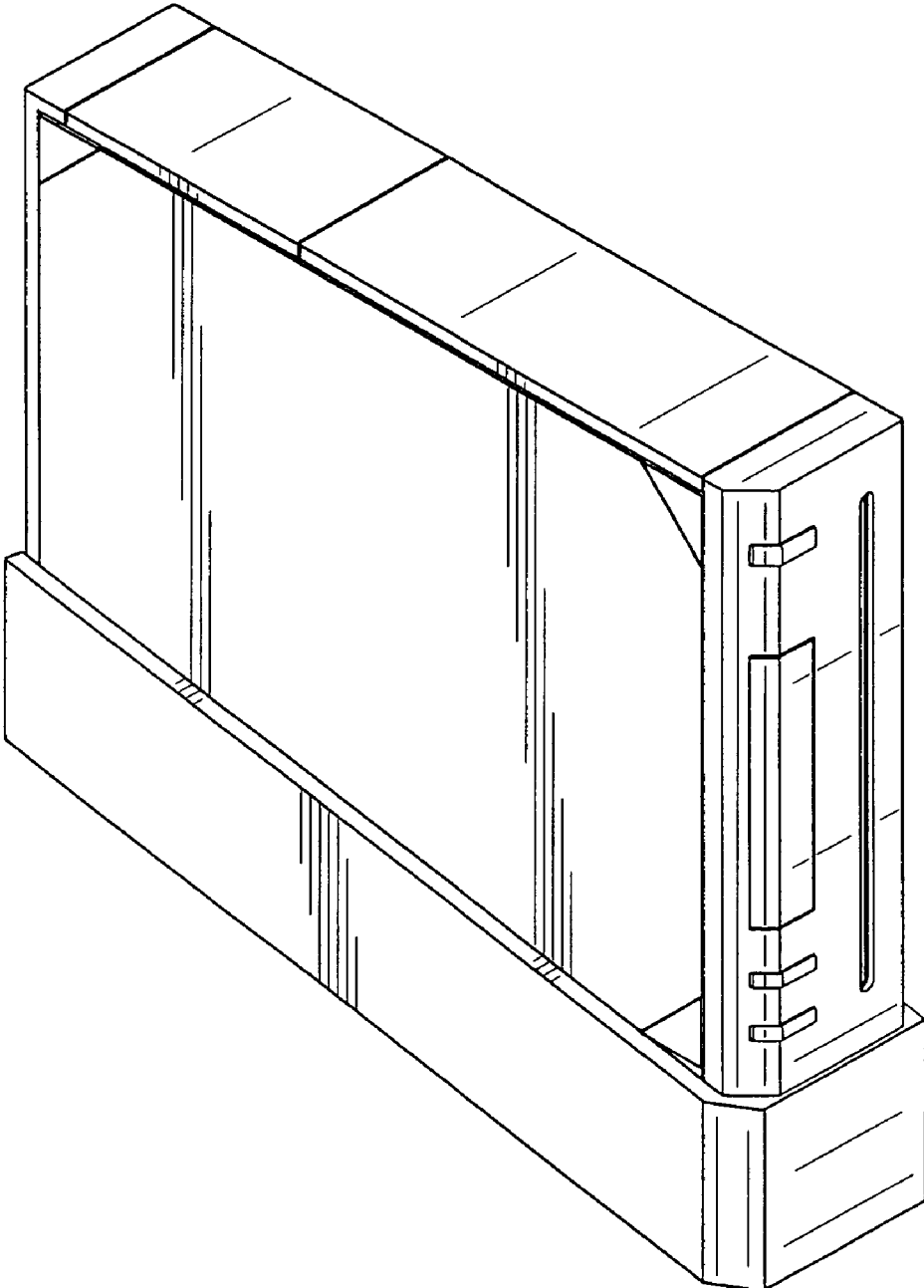

FIG. 2

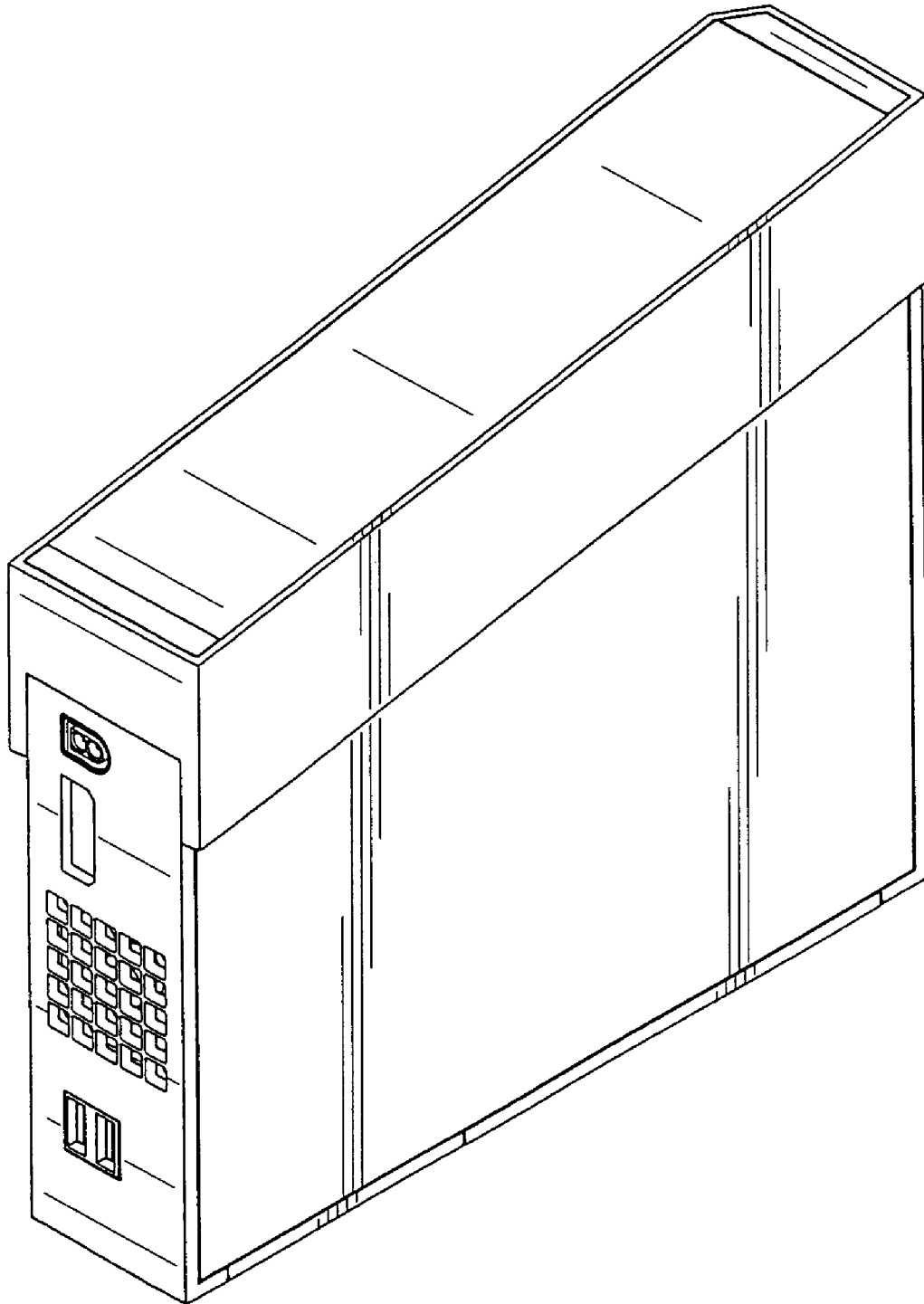

FIG.3

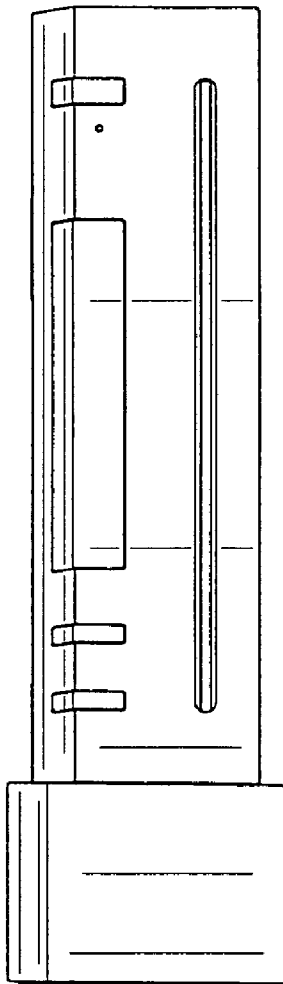

FIG.4

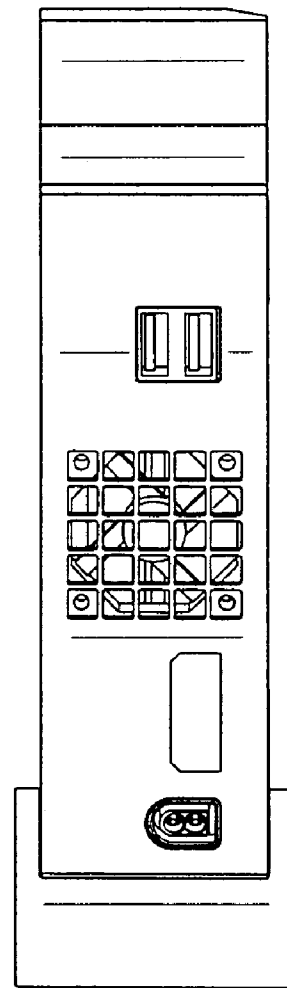

FIG. 5

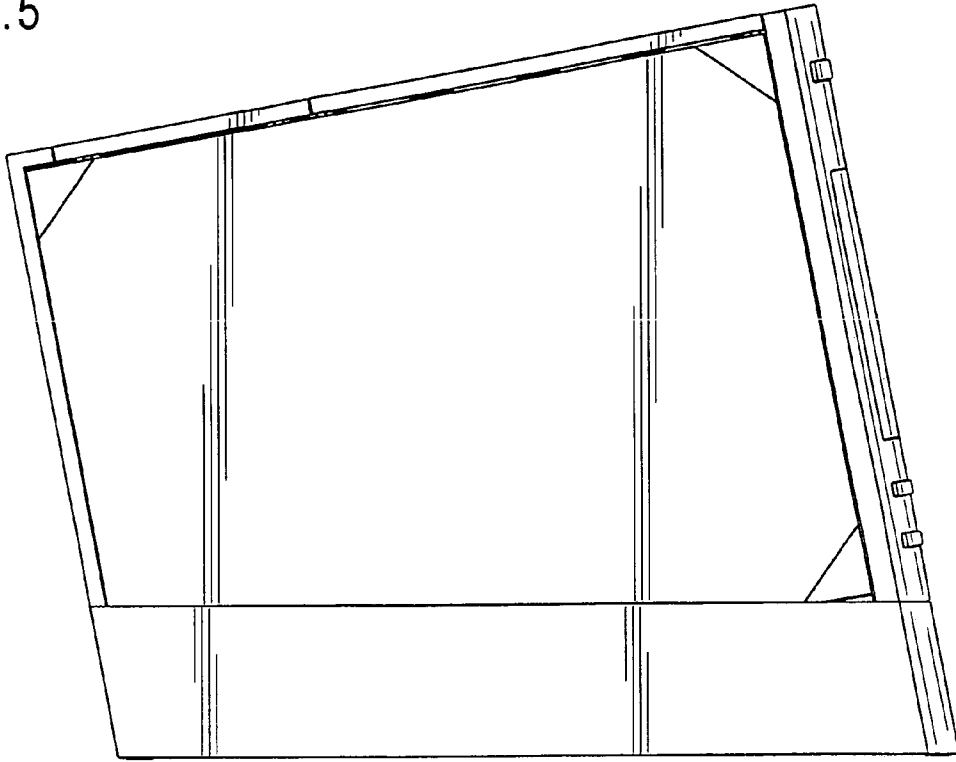

FIG. 6

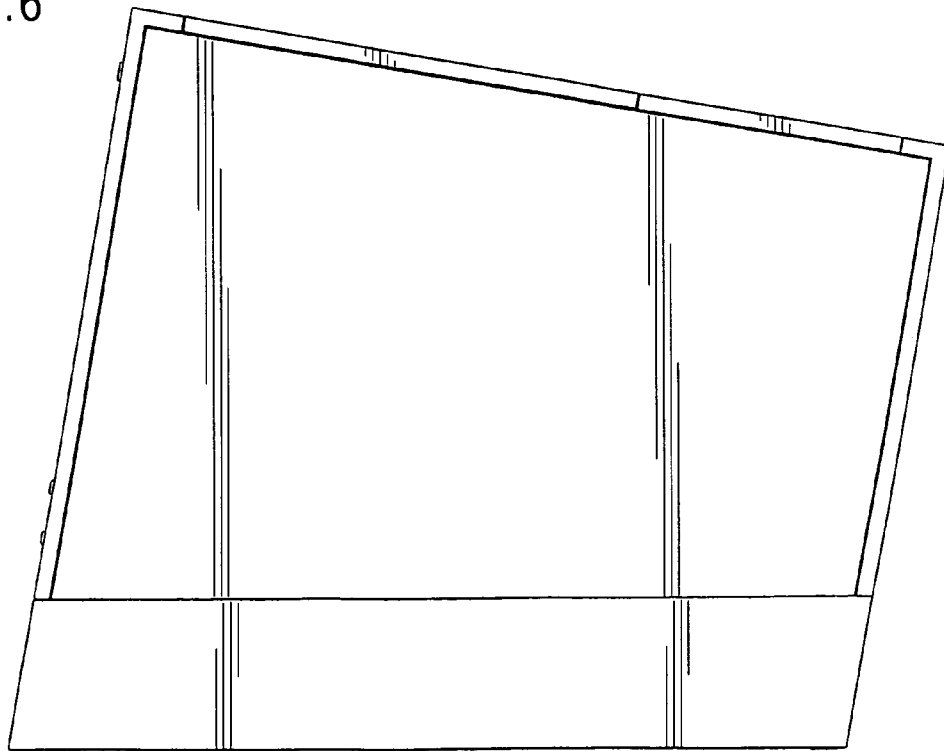

FIG.7

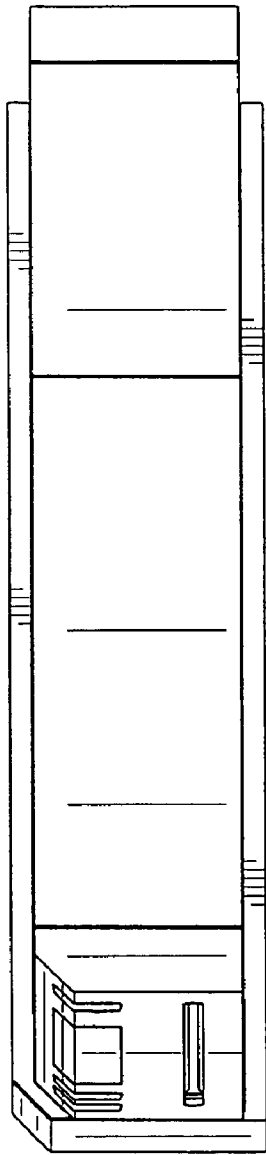

FIG.8

