

No. 831,757.

PATENTED SEPT. 25, 1906.

C. O. WESCOTT & F. P. ROBERTS.

TRACK LAYING MACHINE.

APPLICATION FILED JUNE 26, 1906.

2 SHEETS—SHEET 1.

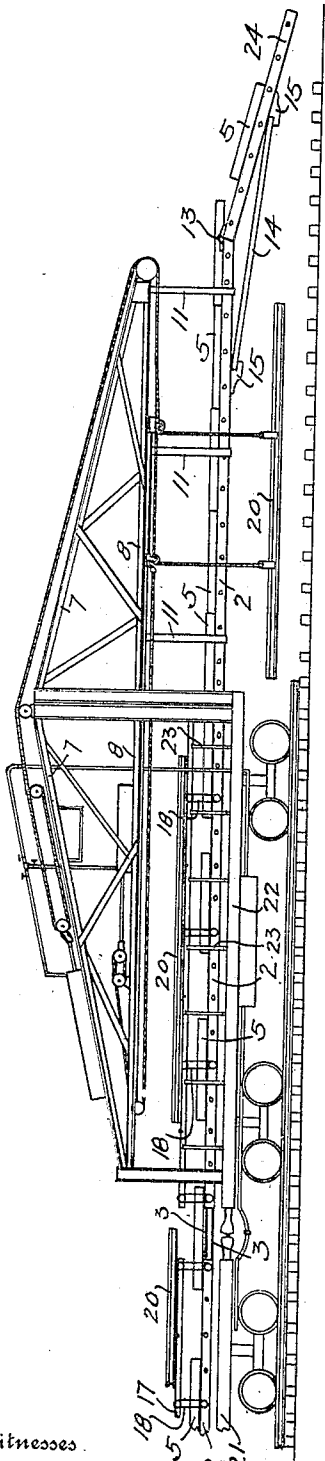

Fig. 1.

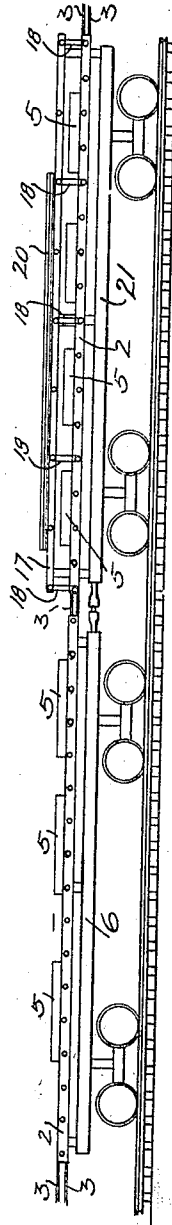

Fig. 2.

Witnesses.

H. Stanley Fogg
G. H. McNamee

Inventors

Charles O. Wescott

Frank P. Roberts

By

R. J. Elliott

Attorney

No. 831,757.

PATENTED SEPT. 25, 1906.

G. O. WESCOTT & F. P. ROBERTS.

TRACK LAYING MACHINE.

APPLICATION FILED JUNE 26, 1906.

2 SHEETS—SHEET 2.

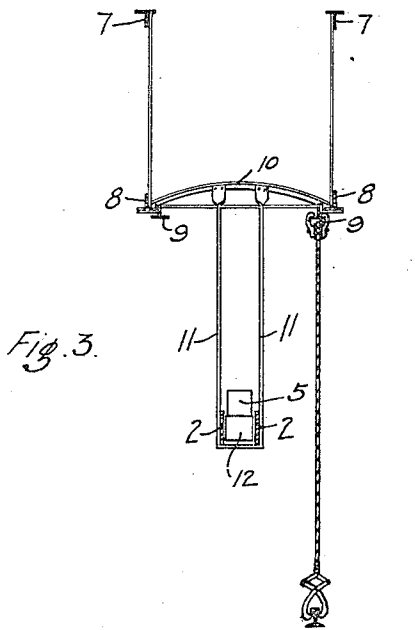

Fig. 3.

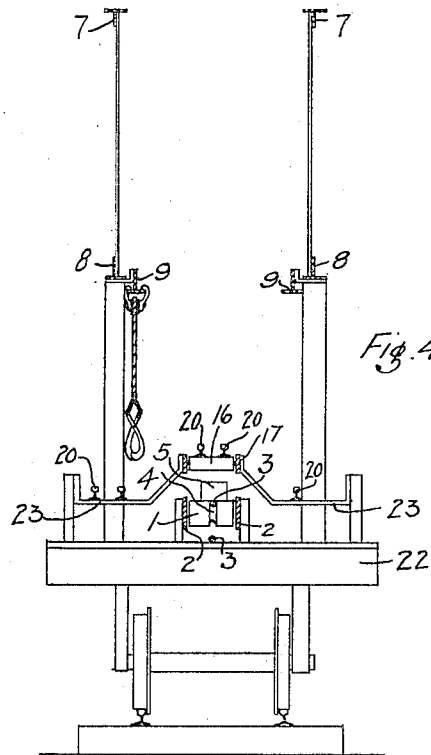

Fig. 4.

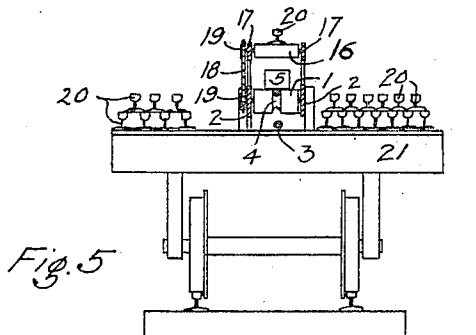

Fig. 5.

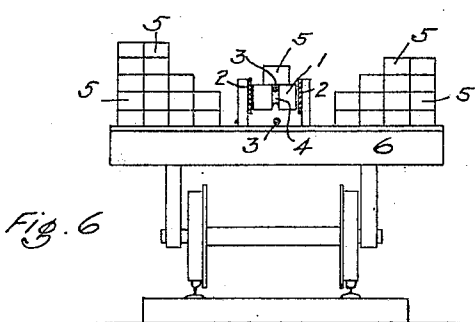

Fig. 6.

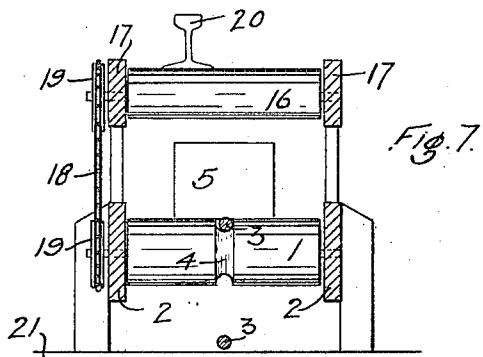

Fig. 7.

Witnesses
H. Stanley Fogg
G. H. McNamee

Inventors
Charles O. Wescott
Frank P. Roberts
R. H. Elliott Attorney

UNITED STATES PATENT OFFICE.

CHARLES O. WESCOTT AND FRANK P. ROBERTS, OF PUYALLUP,
WASHINGTON.

TRACK-LAYING MACHINE.

No. 831,757.

Specification of Letters Patent.

Patented Sept. 25, 1906.

Application filed June 26, 1906. Serial No. 323,524.

To all whom it may concern:

Be it known that we, CHARLES O. WESCOTT and FRANK P. ROBERTS, citizens of the United States of America, residing at Puyallup, in the county of Pierce and State of Washington, have invented certain new and useful Improvements in Track-Laying Machines, of which the following is a specification, reference being had therein to the accompanying drawings.

This invention relates to track-laying machines, and is especially applicable to the track-laying machine for which Letters Patent issued to Chas. O. Wescott on July 10, 1906.

The objects of our invention are to mount on the construction-train a conveyer to carry the ties from the rear portion of the train to a point about fifty feet in front of the train and to carry the rails from the rail-cars, which are located forward of the tie-cars, to the forward car, where the rails are gripped by the carrier, described and claimed in the patent above mentioned, and are carried forward and are lowered to their proper places.

Further objects of our invention are to drive the rail-conveyer from the tie-conveyer and to so construct the conveyer that it will not be affected in length by the curvature of the track, and therefore does not need any compensating arrangement to allow the train to follow the curves of the track without disturbing the conveyer.

We attain these objects by the devices and mechanism illustrated in the accompanying drawings, in which—

Figure 1 is a side view of the forward car of the construction-train. Fig. 2 is a similar view of the middle portion of the train, showing one rail-car and one tie-car. Fig. 3 is a cross-section of the forward extension of the conveyer at a point about fifteen feet forward of the forward car. Fig. 4 is a cross-section of the forward car. Fig. 5 is a cross-section of the rail-car. Fig. 6 is a cross-section of the tie-car, and Fig. 7 is an enlarged cross-section of the conveyer on the rail-car.

Similar numerals of reference refer to similar parts throughout the several views.

The tie-conveyer extends from the rear end of the train to the forward end thereof and consists of a series of rollers 1, mounted horizontally between the frames 2, which are supported above the center line of each car

and preferably extend a short distance beyond each end of each car. Each of the rollers 1 is grooved centrally to receive the endless driving-cable 3, which travels from the rear of the train to the forward car 22 thereof in the grooves 4 of the rollers 1 and back to the rear car, under the conveyer, and above the deck of the cars, where it is driven by any suitable driving mechanism. The ties 5 are stored on the tie-cars 6 on each side of the conveyer and are unloaded therefrom by simply lifting each tie from its place and placing it on the nearest rollers. Since the cable 3 is traveling forward, all the rollers 1 are turning with their upper edges going toward the forward end of the train, and as soon as a tie is placed on the conveyer it presses the cable down in the grooves 4 and is driven forward by the cable and by the rotating rollers.

In the above-mentioned patent the structure which carries the rails from the forward car 22 and lowers them in place on the ties is constructed so as to extend forward from the train and consists practically of two parallel cantalivers formed of upper chords 7 and lower chords 8, suitably connected together by bars and supporting the carrier-tracks 9 from the inner side of the lower chords. We use this cantaliver system to support the forward extension of the tie-conveyer by bridging across from one lower chord 8 to the other lower chord 8 above the carrier-tracks 9 with the bars 10, from which we hang the tie-conveyer frames 2 by means of suitable straps 11. This tie-conveyer extension is hung centrally between and below the cantalivers and extends out practically horizontally to a point beyond their ends and is formed of the side frames 2, which are placed slightly closer together than they are on the train, and the plane rollers 12, supported by the frames 2. As the ties arrive at the end of the cable-driven rollers 1 they pass onto the rollers 12, which are not driven. As each tie gets to this point it pushes all the ties which are in front of it forward along the extension.

At the end of the extension-conveyer is secured an inclined chute 24, which consists of practically the same construction as the tie-conveyer extension and which is supported therefrom by means of hinges 13, secured to the upper edges of the sides 2, and by a strut 14, below the conveyer and compressed be-

tween two blocks 15, secured, respectively, to the lower edges of the conveyer extension and of the chute. As the ties are pushed on the rollers 12 over the end of the conveyer extension they slide down the chute to the ground, the end of the chute being placed about two feet above the grade.

The rail-conveyer consists of a series of rollers 16, mounted between side frames 17, which are supported above the side frames 2 of the tie-conveyer. Preferably every alternate one of the rollers 16 is driven from the roller 1 below it by means of a sprocket-chain 18, which joins the two sprocket-wheels 19, mounted, respectively, on the axles of the rollers 1 and 16. The rail-conveyer does not extend the entire length of the train, but only from the rear rail-car, which is forward of the forward tie-car, to the forward car 22 of the train. The rails 20 are stored either on the deck of the rail-cars 21 or on a platform built thereon at about the level of the top of the rail-conveyer, in which latter case it will not be necessary to lift the rails; but they may be slid directly from the platform to the conveyer-rollers 16. On the forward car 22 are constructed on each side of the rail-conveyer a series of supporting-rods 23, preferably inclined downward therefrom for a short distance and then being horizontal, the said horizontal portion coming under the rail-carrier described in the above-mentioned patent. The rails may be picked up from these supporting-rods 23 and carried forward by the carrier and lowered into place on the ties.

Having now described our invention, what we claim is—

1. In a track-laying machine, the combination of a tie-conveyer extending from end to end of the train and mounted centrally thereof, a structure extending forward of the train, an extension to said tie-conveyer hung centrally from said structure, and an inclined chute extending forward from said extension.

2. In a track-laying machine, the combination of a series of rollers mounted centrally and transversely of the cars and extending from end to end of the train, an endless driving-cable supported centrally on the train by said rollers on one side and returning below said rollers, a structure extending forward of the train, a horizontal series of idle rollers extending forward from the end of said driven rollers and supported centrally from said structure, and an inclined series of idle rollers

extending forward from the end of said horizontal series.

3. In a track-laying machine, the combination of a tie-conveyer extending from end to end of the train and mounted centrally thereof, an endless driving-cable supported centrally on the train by said tie-conveyer and driving said conveyer, a rail-conveyer supported over said tie-conveyer, and driving means connecting said rail-conveyer with said tie-conveyer whereby said rail-conveyer is driven.

4. In a track-laying machine, the combination of a tie-conveyer extending from end to end of the train and mounted centrally thereof, an endless driving-cable supported centrally on the train by said tie-conveyer and driving said conveyer, a structure extending forward of the train, an extension of the tie-conveyer supported centrally by said structure and extending beyond said structure, a rail-conveyer supported over the tie-conveyer, driving means connecting said rail-conveyer with said tie-conveyer whereby said rail-conveyer is driven, an unloading-support on the forward car whereon the rails are unloaded from the rail-conveyer, and means supported by said structure whereby said rails are carried from the unloading-support and placed in position on the ties.

5. In a track-laying machine, the combination of a series of grooved rollers adapted to support and convey ties, an endless cable running in the grooves of said rollers from end to end of the series, a series of plane rollers supported over said grooved rollers and adapted to support and convey rails, and driving means joining said grooved rollers with said plane rollers whereby said plane rollers are driven.

6. In a track-laying machine, the combination of a tie-conveyer extending forward of the forward car and being supported from said car, an inclined chute secured to the end of said tie-conveyer by a strap or hinge, a pair of blocks secured to the lower sides of the conveyer and the chute, and a strut between said blocks.

In testimony whereof we affix our signatures in presence of two witnesses.

CHARLES O. WESCOTT.
FRANK P. ROBERTS.

Witnesses:

H. G. ROWLAND,
E. C. ELLINGTON.