

W. P. PARROTT.

Ore Crusher.

No. 28,499.

Patented May 29, 1860.

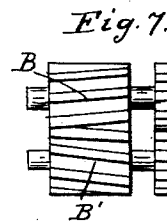
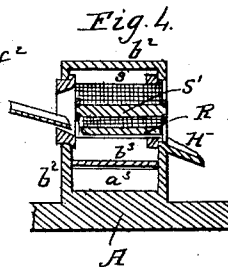
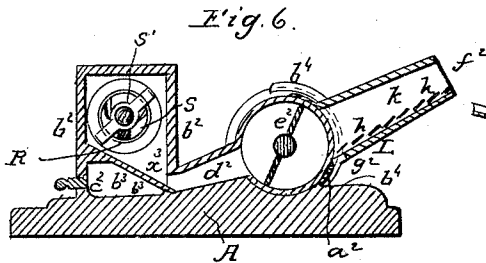
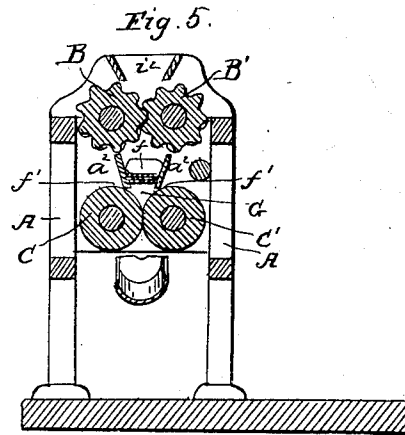
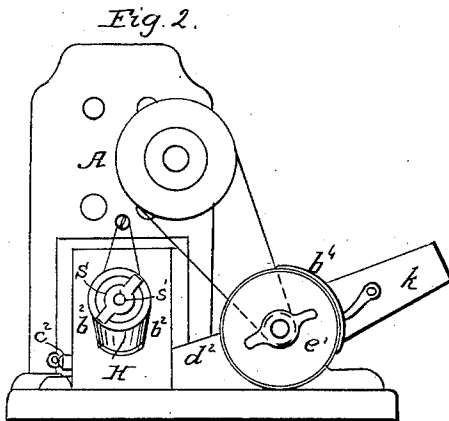
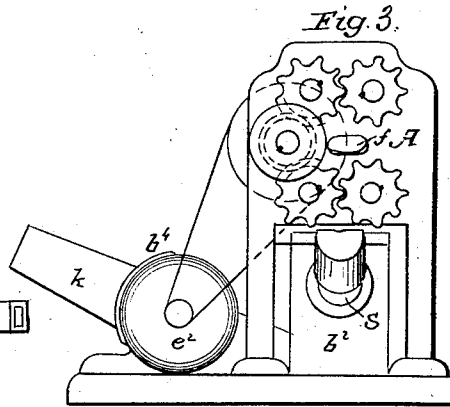
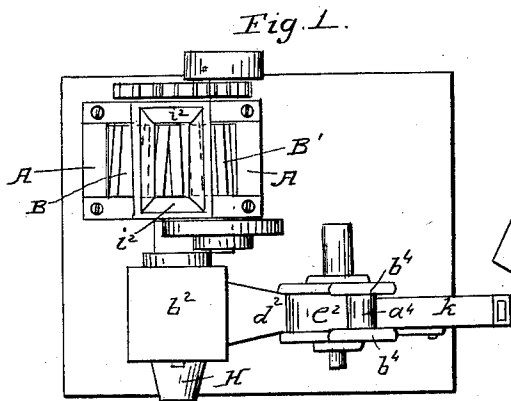

Witnesses:
H. L. Levi
Arthur. Hill.

Inventor:
W. P. Parrott

UNITED STATES PATENT OFFICE.

WILLIAM P. PARROTT, OF BOSTON, MASSACHUSETTS.

IMPROVEMENT IN MACHINES FOR CRUSHING MINERAL ORES.

SPECIFICATION forming part of Letters Patent No. 28,499, dated May 29, 1860.

To all whom it may concern:

Be it known that I, WILLIAM P. PARROTT, civil engineer, of Boston, in the county of Suffolk, in the Commonwealth of Massachusetts, have invented a new and useful or improved machine for crushing mineral ores and separating therefrom the metallic particles with which they may be impregnated; and I do hereby declare that the following is a full and exact description thereof, reference being had to the accompanying drawings, making part of the same.

Figure 1 of such drawings being a top view of my said machine; Fig. 2, a front elevation of it; Fig. 3, a rear elevation of it; Fig. 4, a transverse section taken through its rotary sieve. Fig. 5 is a vertical section taken through the crushing-rollers; Fig. 6, a longitudinal section of the rotary sieve and case, the fan-blower, its conduit, and separator; Fig. 7, a top view of fluted crushing-rollers, showing the angular arrangement of their flutes.

The nature of my invention consists in a combination and arrangement of one or more sets of crushing-rollers, a sifting or screening apparatus, an air-blast or fan-blower, and a discharging spout or conduit provided with a separator so arranged that by the conjoint operation of gravity and a blast of air the mineral matters may be separated from the refuse ore, substantially as herein described; also, in so combining the air-blast or fan-blower case and the conduit and its separator that the latter or the same and the conduit may be adjusted to any desirable angle of inclination relatively to the horizon; also, in so combining the rotary screen with the fan blast or blower and the conduit provided with a separator that the air blown through the conduit shall be made to first pass through the rotary screen, substantially in manner and for the purpose as described; also, in combining a regulating air-hole and plug or equivalent with the case of the rotary screen and with the fan-blower applied to operate therewith and with a discharging conduit and separator; also, in combining the extra inclined sieve or separator a^2 with the rotary screen s , the regulating air-inlets c^2 , and the fan-blast apparatus, its conduit, and separator.

To enable others skilled in the art to make and use my invention, I will proceed to describe its construction and operation.

In the drawings, A represents a strong frame, made of wood or other suitable material, carrying two sets of crushing-rolls B B' and C C', arranged so that the material operated upon may pass from one set to the other. In case the ores are very hard this series or set of rollers may be increased with a similar arrangement of one set below the others. In treating some kinds of ore I prefer to flute the upper or first series of rollers with the flutes not parallel to the axes of the rolls, but placed at an angle or obliquely thereto, and so that those of one roll may be in opposite directions relatively to that of the other, or as represented in Fig. 7, the same being in order that in working the operation of the flutes may resemble the action of shears. The upper set of rolls may have the boxes of their journals so arranged against springs or weighted levers that said rolls may be able to separate or move apart from one another in case a substance too hard for the rolls to crush may be taken in between them.

The rolls may be made with chilled-iron surfaces, or of steel or other hard metal, the lower or last series being so arranged as to run very closely together and be held firmly in that position in order that by their operation the ore may be reduced to or nearly to an impalpable powder.

Under the first series of rolls a grate G, with suitable passages or spaces $a^2 a^2$ in it, is placed, it being slightly inclined toward one side of the frame A in order to arrest those particles which may be too large or unsuitable to pass between the next set of rolls, for in copper ores it will often be the case that there may be portions of metallic parts which may be already partially cleaned and be too large and irregular in their form to pass between the lower rollers. The portions thus assorted may be discharged by a conductor f into a suitable receptacle. The other portions by another conductor f' are to be carried to the next series of rolls, and so on to the last series, when there may be more than two series. After passing between the rollers the crushed material should be conducted into a rotary screen or sieve s . This screen may be constructed of wire net or perforated plate and may contain within it rubbers R R, suspended from the screen-shaft s' and hanging vertically by their own weight, the shaft revolving within their stirrups or suspension devices. These rubbers may be

segmental in section and be placed very close to the inside surface of their screen in order that the powdered material or ore that may be caked by the operation of the rolls may be completely pulverized and caused to pass through the meshes of the rotary screen. The metallic particles being flattened by the rolls will, unless they should be very small, be assorted by the screen and pass out at its open end and into a suitable spout H. The smaller particles, with the dust containing them, will drop through the meshes of the sieve and upon an inclined plane a^3 , arranged in the sieve-box b^3 , as shown in Fig. 6, and furnished with long slits or air-apertures $b^3 b^3$. Below and in rear of the said inclined plane a^3 there is an air inlet or opening c^2 , made through the side of the box b^3 and provided with a plug. The powdered ore falling on the plane will be conducted by it to a spout or conduit d' , leading out of the case b^3 and into a fan-blower or air-blast apparatus, (shown at e^2 .) By being drawn through the rotary sieve the current of air facilitates the passage of the mineral particles through its meshes as well as their transmission into the fan-blast apparatus. The particles will be carried forward by the current of air and blown into a discharging spout or conduit k , which should be so arranged or applied to the fan-case as to be capable of being adjusted to any desirable angle of elevation in order to control the action of gravitation on the powdered particles passing up the conduit, which is constructed with two discharging-passages $f^2 g^2$, one being at the outer end of the conduit and the other near the case and below a dividing perforated partition or separator h or an arrangement of ripples or bars having spaces between them for communicating with the part L of the conduit, such part being closed at its upper end, so that there need be no current of air through it.

In applying the discharging-conduit of the air-blast apparatus to its case the two may be provided with two sets of curved flanges $a^4 a^4 b^4 b^4$, which may project from them, respectively, one set being arranged so as to lap over the other and keep the conduit close up to the curved periphery of the case and allow such conduit to be adjusted to any angle of inclination as well as to be removed from the case when necessary.

Upon the lower end of the part L the discharging-passage g^2 is placed, it being for the purpose of removing the particles which are thrown into said part L.

When the machine is put into operation, the hopper v^2 of the upper rolls is to be charged with a suitable quantity of the ore, which by the action of such rolls will afterward be reduced to a gross powder, the inclined screen immediately below them separating the irregular masses of metal, which will be carried off out of the apparatus, the balance falling through the inclined grate and being di-

rected upon and crushed by the other rolls. From them it passes into the revolving screen s , where the next larger particles of metal are separated, and the material, thoroughly pulverized by the action of the rubbers, will be drawn into the blower and by it be thrown into its discharging-conduit. As the mass is blown through the conduit by currents of air created by the fan, the metallic particles, being heavier than the dust, will take, gradually, the lower position and be arrested by the ripples and will fall back between them and into the lower trunk or part L, and finally will be discharged out of it. The trunk may be continued to a convenient length to carry the earth now cleaned from the metal to a suitable point of deposit.

I am aware that rollers have been used for crushing ores and screens used for separating the grains of different sizes for the purpose of washing with water. I do not claim a combination of rollers and screens for that purpose. By means of the air-inlet c^2 and its plug the current of air drawn through the rotary sieve may be moderated or varied as circumstances may require.

I claim—

1. The above-described combination and arrangement of one or more sets of crushing-rollers, B, B', C, C', a sifting or screening apparatus (consisting of a rotary screen S, and its case b^2), an air blast or blower e^2 , and a discharging-conduit, k , provided with a separator h , so arranged that by the conjoint action of gravity and a blast of air, the mineral matters may be separated from the refuse ore, the whole being for crushing ore and separating the metal therefrom substantially as specified.

2. So combining the air-blast or fan-blower, e^2 , and the conduit, k , and its separator, h , that the said conduit and separator may be adjusted at any desirable angle of inclination relatively to the horizon.

3. So combining the rotary screen-case, b^2 , with the fan blast or blower, e^2 , and the conduit, k , provided with a separator, h , that the air blown through the conduit shall first be made to pass through the rotary sieve substantially in manner and for the purpose as described.

4. Combining a regulating air-hole, c^2 , and plug or its equivalent with the case, b , of the rotary screen S and with the fan-blower, e^2 , applied to operate therewith and with a discharging-conduit k , furnished with a separator h , as specified.

5. Combining the inclined screen, a^3 , of the rotary sieve-case with the rotary screen, S, the regulating air-inlet, c^2 , and the fan-blast apparatus e^2 , its conduit, k , and separator, h .

WM. P. PARROTT.

Witnesses:

R. H. EDDY,
F. P. HALE, Jr.