

(19) World Intellectual Property Organization
International Bureau



(43) International Publication Date
30 June 2011 (30.06.2011)

PCT

(10) International Publication Number
WO 2011/075908 A1

- (51) **International Patent Classification:**
H04W 16/02 (2009.01) H04B 7/26 (2006.01)
- (21) **International Application Number:**
PCT/CN2009/076048
- (22) **International Filing Date:**
25 December 2009 (25.12.2009)
- (25) **Filing Language:** English
- (26) **Publication Language:** English
- (71) **Applicant (for all designated States except US):** NOKIA SIEMENS NETWORKS OY [FI/FI]; Karaportti 3, FIN-02610 Espoo (FI).
- (72) **Inventors; and**
- (75) **Inventors/Applicants (for US only):** CHE, Xiangguang [CN/CN]; South 4-2-301, Feng Dan Li She, No. 1, Jian Cai Cheng Zhong Lu, Xi San Qi, Haidian District, Beijing 100096 (CN). CHMIEL, Mieszko [PL/PL]; Powstancow Slaskich 50/23, PL-48-340 Glucholazy (PL).
- (74) **Agent:** KING & WOOD PRC LAWYERS; 31/F, Office Tower A, 39 Dongsanhuan Zhonglu, Chaoyang District, Beijing 100022 (CN).
- (81) **Designated States (unless otherwise indicated, for every kind of national protection available):** AE, AG, AL, AM,

AO, AT, AU, AZ, BA, BB, BG, BH, BR, BW, BY, BZ, CA, CH, CL, CN, CO, CR, CU, CZ, DE, DK, DM, DO, DZ, EC, EE, EG, ES, FI, GB, GD, GE, GH, GM, GT, HN, HR, HU, ID, IL, IN, IS, JP, KE, KG, KM, KN, KP, KR, KZ, LA, LC, LK, LR, LS, LT, LU, LY, MA, MD, ME, MG, MK, MN, MW, MX, MY, MZ, NA, NG, NI, NO, NZ, OM, PE, PG, PH, PL, PT, RO, RS, RU, SC, SD, SE, SG, SK, SL, SM, ST, SV, SY, TH, TJ, TM, TN, TR, TT, TZ, UA, UG, US, UZ, VC, VN, ZA, ZM, ZW.

(84) **Designated States (unless otherwise indicated, for every kind of regional protection available):** ARIPO (BW, GH, GM, KE, LS, MW, MZ, NA, SD, SL, SZ, TZ, UG, ZM, ZW), Eurasian (AM, AZ, BY, KG, KZ, MD, RU, TJ, TM), European (AT, BE, BG, CH, CY, CZ, DE, DK, EE, ES, FI, FR, GB, GR, HR, HU, IE, IS, IT, LT, LU, LV, MC, MK, MT, NL, NO, PL, PT, RO, SE, SI, SK, SM, TR), OAPI (BF, BJ, CF, CG, CI, CM, GA, GN, GQ, GW, ML, MR, NE, SN, TD, TG).

Declarations under Rule 4.17:

— of inventorship (Rule 4.17(iv))

Published:

— with international search report (Art. 21(3))

(54) Title: MAPPING REFERENCE SIGNAL FOR MULTI-CELL TRANSMISSION

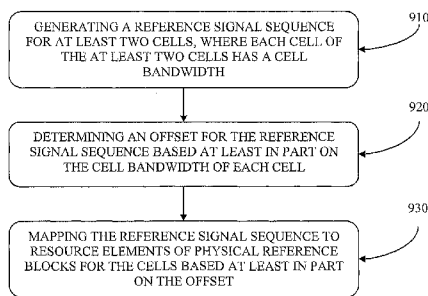

Figure 9

(57) **Abstract:** Described is a method for the mapping of reference signals. The method includes generating a reference signal sequence for two or more cells, where each cell of the two or more cells has a cell bandwidth. The method also includes determining an offset for the reference signal sequence based at least in part on the cell bandwidth of each cell. Mapping the reference signal sequence to resource elements of physical resource blocks for the cells based at least in part on the offset is included in the method. Apparatus and computer readable media are also disclosed.



WO 2011/075908 A1

MAPPING REFERENCE SIGNAL FOR MULTI-CELL TRANSMISSION

TECHNICAL FIELD:

The exemplary and non-limiting embodiments of this invention relate generally to wireless communication systems, methods, devices and computer programs and, more specifically, relate to mapping of reference signals for multi-cell transmission.

BACKGROUND:

This section is intended to provide a background or context to the invention that is recited in the claims. The description herein may include concepts that could be pursued, but are not necessarily ones that have been previously conceived or pursued. Therefore, unless otherwise indicated herein, what is described in this section is not prior art to the description and claims in this application and is not admitted to be prior art by inclusion in this section.

The following abbreviations that may be found in the specification and/or the drawing figures are defined as follows:

3GPP	third generation partnership project
BW	bandwidth
CDM	code division multiplexing
C-MIMO	cooperative MIMO
CoMP	coordinated multi-point transmission/reception
CRS	common reference signal
CSI	channel state information
DCI	downlink control information
DL	downlink (eNB towards UE)
DM-RS	demodulation RS
DRS	dedicated reference signal
eNB	E-UTRAN Node B (evolved Node B)
EPC	evolved packet core
E-UTRA	evolved UTRA
E-UTRAN	evolved UTRAN (LTE)

HARQ	hybrid automatic repeat request
ID	identity
JP	joint transmission/processing
LTE	long term evolution of UTRAN (E-UTRAN)
LTE-A	long term evolution advanced
MAC	medium access control (layer 2, L2)
MIMO	multiple input multiple output
MM/MME	mobility management/mobility management entity
MU	multi user
MU-MIMO	multi user MIMO
Node B	base station
O&M	operations and maintenance
OFDM	orthogonal frequency division multiplexing
OFDMA	orthogonal frequency division multiple access
PCI	physical cell ID
PDCP	packet data convergence protocol
PHY	physical (layer 1, L1)
PRB	physical resource block
QPSK	quadrature phase shift keying
RE	resource element
Rel	release
RLC	radio link control
RRC	radio resource control
RRM	radio resource management
RS	reference signal
SC-FDMA	single carrier, frequency division multiple access
SDM	space division multiplexing
S-GW	serving gateway
SI	system information
SU	single user
SU-MIMO	single user MIMO
TP	transmission point

TPMI	transmitted precoding matrix indicator
TTI	transmission time interval
UE	user equipment, such as a mobile station or mobile terminal
UL	uplink (UE towards eNB)
UMTS	universal mobile telecommunications system
URS	UE-specific reference signal
UTRA	UMTS terrestrial radio access
UTRAN	universal terrestrial radio access network
WID	work item description

A communication system known as evolved UTRAN (E-UTRAN, also referred to as UTRAN-LTE or as E-UTRA) has been specified within 3GPP. The DL access technique is OFDMA, and the UL access technique is SC-FDMA.

One specification of interest is 3GPP TS 36.300, V9.1.0 (2009-09), "3rd Generation Partnership Project; Technical Specification Group Radio Access Network; Evolved Universal Terrestrial Radio Access (E-UTRA) and Evolved Universal Terrestrial Access Network (E-UTRAN); Overall description; Stage 2 (Release 9)", incorporated by reference herein in its entirety.

Figure 1 reproduces Figure 4.1 of 3GPP TS 36.300, and shows the overall architecture of the E-UTRAN system. The E-UTRAN system includes eNBs, providing the E-UTRA user plane (PDCP/RLC/MAC/PHY) and control plane (RRC) protocol terminations towards the UE (not shown). The eNBs are interconnected with each other by means of an X2 interface. The eNBs are also connected by means of an S1 interface to an EPC, more specifically to a MME (Mobility Management Entity) by means of a S1 MME interface and to a Serving Gateway (SGW) by means of a S1 interface. The S1 interface supports a many-to-many relationship between MMEs/S-GW and eNBs.

The eNB hosts the following functions:

- functions for RRM: Radio Bearer Control, Radio Admission Control, Connection Mobility Control, Dynamic allocation of resources to UEs in

both UL and DL (scheduling);

- IP header compression and encryption of the user data stream;
- selection of a MME at UE attachment;
- routing of User Plane data towards the Serving Gateway;
- scheduling and transmission of paging messages (originated from the MME);
- scheduling and transmission of broadcast information (originated from the MME or O&M); and
- a measurement and measurement reporting configuration for mobility and scheduling.

UE-specific reference signals (URS) (also known as dedicated reference signal (DRS) or demodulation RS (DM-RS) within the context of LTE-A) were agreed to be used as the demodulation reference signal in the downlink of Rel-10 and Rel-9. These reference signals are present in the transmitted physical resource blocks (PRBs) and the transmitted spatial layers. They undergo the same precoding operations as the corresponding data channel. Benefits of URSs include non-constrained precoding, no need for transmit precoding matrix index (TPMI) signaling in the downlink and reduced overhead compared to non-precoded common reference signals (CRS). See further, 3GPP TR 36.814, v0.4.1, "Further Advancements for E-UTRA Physical Layer Aspects", February 2009 (attached as Exhibit A and incorporated by referenced in its entirety) and 3GPP WID RP-090359, "Enhanced DL transmission for LTE", March 2009 (attached as Exhibit B and incorporated by referenced in its entirety).

Coordinated multi-point transmission/reception (CoMP) is considered a promising technique in LTE-A to achieve high cell-edge and cell average throughput gains. DRS mapping and initialization is to be used in LTE Rel-9 (dual layer beamforming) and in LTE-A (higher order DL SU-MIMO, MU-MIMO and CoMP) as well as in LTE-A Rel-10. See further, 3GPP TR 36.814 (Exhibit A); 3GPP R1-093890, "Considerations on Initialization and Mapping of DM-RS Sequence", Nokia Siemens Networks, Nokia, October 2009 (attached as Exhibit C and incorporated by referenced in its entirety); 3GPP CR 0141R1, R1-095131, "CR 36.211 Introduction of enhanced dual layer

transmission”, November 2009 (attached as Exhibit D and incorporated by referenced in its entirety) and 3GPP R1-093697, “Proposed Way forward on Rel-9 Dual-layer beamforming for TDD and FDD” August 2009 (attached as Exhibit E and incorporated by referenced in its entirety).

Figure 2 illustrates an exemplary LTE-A Rel-9/10 URS scrambling sequence generation and mapping (for rank 1 - 2). The initialization and mapping of the URS scrambling sequences in LTE Rel-9/10 have the following properties: a re-initialization period of 1 subframe (1ms) (sequence periodicity: one radio frame, 10ms); a sequence for example, QPSK Gold initialized with Scrambling ID, Cell ID and subframe number; and a mapping, for example, the generated sequence assumes the maximum system BW in a subframe and maps to URS resource elements (REs) frequency-first (time-later) for the assumed system BW. The actual URS sequence may correspond to the used/allocated PRBs (pilots of multiple layers or SD multiplexed users can be separated by the use of an orthogonal code on top of the scrambling sequence). See further R1-093890 (Exhibit C) and R1-095131 (Exhibit D).

As shown, each RE in the resource grid represents a time-domain segment and frequency domain segment. As shown, one PRB encompasses twelve frequency domain segments of the system bandwidth and fourteen (or twelve for the extended cyclic prefix) time domain segments of the subframe (168 total REs or 144 total REs for the extended cyclic prefix). The PRB may be considered a PRB pair where the first seven (or six for the extended cyclic prefix) time domain segments represent even-numbered slots and the second seven (or six for the extended cyclic prefix) time domain segments represent odd-numbered slots.

The sequence of URS mapping progresses along the frequency domain for a first time domain segment then after reaching the maximum system bandwidth restarts in a first frequency domain segment at the next appropriate time domain segment.

Figure 3 illustrates exemplary URS sequences for different BWs (the DC subcarrier is ignored for simplicity). In other relative frequency positions of transmission points with different bandwidths MU joint transmission/processing CoMP (JP CoMP) is not possible. As shown in Figure 3, a given PRB pair (PRB with a given number/index) will use the same parts of the scrambling sequence regardless of the actual cell BW.

This operation is sufficient for the case when 1) cooperating cells have the same BW and their center frequencies (e.g., DC subcarriers) are aligned or 2) cooperating cells have different BWs and their first PRBs (the lowest frequency PRBs) are frequency aligned. In other cases (e.g. when the BWs of cooperating cells are different and are center aligned), MU JP CoMP based on code division multiplexed (CDMed) DRS may not be possible due to scrambling sequences on overlapping PRBs of cooperating cells not being in-sync (e.g., not the same).

The problem of reference signal sequence variance due to different cell BWs was noticed for CRS in Rel-8. The Rel-8 CRS solution was to use the sequence re-initialization period of one OFDM symbol, generate the sequence for the max system BW and use the central part of the sequence in a given BW. Therefore, the CRS sequence in the central PRBs would not depend on the system BW.

Although the DRS sequence can also be centered so that its central elements are invariant to the system BW, the disadvantage of this solution is that JP CoMP with transmission points of different BWs would be only possible in case the center frequencies of transmission points are aligned.

See further 3GPP TS 36.211, v8.8.0, "Evolved Universal Terrestrial Radio Access (E-UTRA); Physical channels and modulation", September 2009 (attached as Exhibit F and incorporated by referenced in its entirety) regarding the details of the Rel-8 CRS solution.

What is needed is a technique to sequence reference signals which can accommodate different cell BWs and does not require a specific frequency alignment.

SUMMARY

The below summary section is intended to be merely exemplary and non-limiting.

The foregoing and other problems are overcome, and other advantages are realized, by the use of the exemplary embodiments of this invention.

In a first aspect thereof an exemplary embodiment of this invention provides a method for mapping of RSs. The method includes generating a RS sequence for two or

more cells, where each cell of the two or more cells has a cell BW. The method also includes determining an offset for the RS sequence based at least in part on the cell BW of each cell. Mapping the RS sequence to REs of PRBs for the cells based at least in part on the offset is included in the method.

In another aspect thereof an exemplary embodiment of this invention provides an apparatus for mapping of RSs. The apparatus includes at least one processor; and at least one memory including computer program code. The at least one memory and the computer program code are configured to, with the at least one processor, cause the apparatus to perform operations. The operations include to generate a RS sequence for two or more cells, where each cell of the two or more cells has a cell BW. The operations also include to determine an offset for the RS sequence based at least in part on the cell BW of each cell. To mapping the RS sequence to REs of PRBs for the cells based at least in part on the offset is included in the operations.

In a further aspect thereof an exemplary embodiment of this invention provides a computer readable medium tangibly encoded with a computer program executable by a processor to perform actions for mapping of RSs. The actions include generating a RS sequence for two or more cells, where each cell of the two or more cells has a cell BW. The actions also include determining an offset for the RS sequence based at least in part on the cell BW of each cell. Mapping the RS sequence to REs of PRBs for the cells based at least in part on the offset is included in the actions.

In another aspect thereof an exemplary embodiment of this invention provides an apparatus for mapping of RSs. The apparatus includes means for generating a RS sequence for two or more cells, where each cell of the two or more cells has a cell BW. The apparatus also includes means for determining an offset for the RS sequence based at least in part on the cell BW of each cell. Means for mapping the RS sequence to REs of PRBs for the cells based at least in part on the offset is included in the apparatus.

BRIEF DESCRIPTION OF THE DRAWINGS

The foregoing and other aspects of exemplary embodiments of this invention are made more evident in the following Detailed Description, when read in conjunction with the attached Drawing Figures, wherein:

Figure 1 reproduces Figure 4 of 3GPP TS 36.300, and shows the overall architecture

of the E UTRAN system.

Figure 2 illustrates an exemplary LTE-A Rel-9/10 URS scrambling sequence generation and mapping.

Figure 3 illustrates an exemplary URS sequences for different bandwidths (BWs).

Figure 4 shows a simplified block diagram of exemplary electronic devices that are suitable for use in practicing various exemplary embodiments of this invention.

Figure 5 shows a more particularized block diagram of an exemplary user equipment such as that shown at Figure 4.

Figure 6 illustrates exemplary URS sequences for different bandwidths (BWs) in accordance with this invention.

Figure 7 illustrates an exemplary scrambling sequence mapping in accordance with this invention for two PRBs.

Figure 8 illustrates an exemplary scrambling sequence mapping in accordance with this invention for one PRBs where the offset is 1 PRB.

Figure 9 is a logic flow diagram that illustrates the operation of an exemplary method, and a result of execution of computer program instructions embodied on a computer readable memory, in accordance with various exemplary embodiments of this invention.

DETAILED DESCRIPTION

Various exemplary embodiments in accordance with this invention relate to an LTE-Advanced Study Item (or a Work Item) in Rel-10/11: more specifically, downlink UE-specific reference signal design in support of cooperative multi-cell transmission/reception (CoMP or C-MIMO) and related scrambling sequence mapping. Reference signals in support of the Joint Transmission/Processing flavor of CoMP (JP CoMP) may be used in situations where the transmission points (e.g. participating cells) have unequal bandwidths.

Before describing in further detail various exemplary embodiments of this invention, reference is made to Figure 4 for illustrating a simplified block diagram of various electronic devices and apparatus that are suitable for use in practicing exemplary embodiments of this invention.

In the wireless system 430 of Figure 4, a wireless network 435 is adapted for communication over a wireless link 432 with an apparatus, such as a mobile communication device which may be referred to as a UE 410, via a network access node, such as a Node B (base station), and more specifically an eNB 420. The network 435 may include a network control element (NCE) 440 that may include the MME/SGW functionality shown in Figure 1, and which provides connectivity with a network, such as a telephone network and/or a data communications network (e.g., the internet 438).

The UE 410 includes a controller, such as a computer or a data processor (DP) 414, a computer-readable memory medium embodied as a memory (MEM) 416 that stores a program of computer instructions (PROG) 418, and a suitable wireless interface, such as radio frequency (RF) transceiver 412, for bidirectional wireless communications with the eNB 420 via one or more antennas.

The eNB 420 also includes a controller, such as a computer or a data processor (DP) 424, a computer-readable memory medium embodied as a memory (MEM) 426 that stores a program of computer instructions (PROG) 428, and a suitable wireless interface, such as RF transceiver 422, for communication with the UE 410 via one or more antennas. The eNB 420 is coupled via a data/control path 434 to the NCE 440. The path 434 may be implemented as the S1 interface shown in Figure 1. The eNB 420 may also be coupled to another eNB via data/control path 436, which may be implemented as the X2 interface shown in Figure 1.

The NCE 440 includes a controller, such as a computer or a data processor (DP) 444, a computer-readable memory medium embodied as a memory (MEM) 446 that stores a program of computer instructions (PROG) 448.

At least one of the PROGs 418, 428 and 448 is assumed to include program instructions that, when executed by the associated DP, enable the device to operate in accordance with exemplary embodiments of this invention, as will be discussed below in greater detail.

That is, various exemplary embodiments of this invention may be implemented at least in part by computer software executable by the DP 414 of the UE 410; by the DP 424 of the eNB 420; and/or by the DP 444 of the NCE 440, or by hardware, or by a

combination of software and hardware (and firmware).

The UE 410 and the eNB 420 may also include dedicated processors, for example resource scheduler 415 and resource scheduler 425.

In general, the various embodiments of the UE 410 can include, but are not limited to, cellular telephones, personal digital assistants (PDAs) having wireless communication capabilities, portable computers having wireless communication capabilities, image capture devices such as digital cameras having wireless communication capabilities, gaming devices having wireless communication capabilities, music storage and playback appliances having wireless communication capabilities, Internet appliances permitting wireless Internet access and browsing, as well as portable units or terminals that incorporate combinations of such functions.

The computer readable MEMs 416, 426 and 446 may be of any type suitable to the local technical environment and may be implemented using any suitable data storage technology, such as semiconductor based memory devices, flash memory, magnetic memory devices and systems, optical memory devices and systems, fixed memory and removable memory. The DPs 414, 424 and 444 may be of any type suitable to the local technical environment, and may include one or more of general purpose computers, special purpose computers, microprocessors, digital signal processors (DSPs) and processors based on a multicore processor architecture, as non-limiting examples. The wireless interfaces (e.g., RF transceivers 412 and 422) may be of any type suitable to the local technical environment and may be implemented using any suitable communication technology such as individual transmitters, receivers, transceivers or a combination of such components.

Figure 5 illustrates further detail of an exemplary UE in both plan view (left) and sectional view (right), and the invention may be embodied in one or some combination of those more function-specific components. At Figure 5 the UE 410 has a graphical display interface 520 and a user interface 522 illustrated as a keypad but understood as also encompassing touch-screen technology at the graphical display interface 520 and

voice-recognition technology received at the microphone 524. A power actuator 526 controls the device being turned on and off by the user. The exemplary UE 410 may have a camera 528 which is shown as being forward facing (e.g., for video calls) but may alternatively or additionally be rearward facing (e.g., for capturing images and video for local storage). The camera 528 is controlled by a shutter actuator 530 and optionally by a zoom actuator 532 which may alternatively function as a volume adjustment for the speaker(s) 534 when the camera 528 is not in an active mode.

Within the sectional view of Fig. 5 are seen multiple transmit/receive antennas 536 that are typically used for cellular communication. The antennas 536 may be multi-band for use with other radios in the UE. The operable ground plane for the antennas 536 is shown by shading as spanning the entire space enclosed by the UE housing though in some embodiments the ground plane may be limited to a smaller area, such as disposed on a printed wiring board on which the power chip 538 is formed. The power chip 538 controls power amplification on the channels being transmitted and/or across the antennas that transmit simultaneously where spatial diversity is used, and amplifies the received signals. The power chip 538 outputs the amplified received signal to the radio-frequency (RF) chip 540 which demodulates and downconverts the signal for baseband processing. The baseband (BB) chip 542 detects the signal which is then converted to a bit-stream and finally decoded. Similar processing occurs in reverse for signals generated in the apparatus 410 and transmitted from it.

Signals to and from the camera 528 pass through an image/video processor 544 which encodes and decodes the various image frames. A separate audio processor 546 may also be present controlling signals to and from the speakers 534 and the microphone 524. The graphical display interface 520 is refreshed from a frame memory 548 as controlled by a user interface chip 550 which may process signals to and from the display interface 520 and/or additionally process user inputs from the keypad 522 and elsewhere.

Certain embodiments of the UE 410 may also include one or more secondary radios such as a wireless local area network radio WLAN 537 and a Bluetooth® radio 539,

which may incorporate an antenna on-chip or be coupled to an off-chip antenna. Throughout the apparatus are various memories such as random access memory RAM 543, read only memory ROM 545, and in some embodiments removable memory such as the illustrated memory card 547. The various programs 418 are stored in one or more of these memories. All of these components within the UE 410 are normally powered by a portable power supply such as a battery 549.

Processors 538, 540, 542, 544, 546, 550, if embodied as separate entities in a UE 410 or eNB 420, may operate in a slave relationship to the main processor 414, 424, which may then be in a master relationship to them. Embodiments of this invention are most relevant to the power chip 538, though it is noted that other embodiments need not be disposed there but may be disposed across various chips and memories as shown or disposed within another processor that combines some of the functions described above for Figure 5. Any or all of these various processors of Fig. 5 access one or more of the various memories, which may be on-chip with the processor or separate therefrom. Similar function-specific components that are directed toward communications over a network broader than a piconet (e.g., components 536, 538, 540, 542-545 and 547) may also be disposed in exemplary embodiments of the access node 420, which may have an array of tower-mounted antennas rather than the two shown at Fig. 5.

Note that the various chips (e.g., 538, 540, 542, etc.) that were described above may be combined into a fewer number than described and, in a most compact case, may all be embodied physically within a single chip.

Various exemplary embodiments in accordance with this invention introduce an offset to shift the mapped reference signal sequence such that the reference signal scrambling sequence from multiple transmission points can be the same in PRBs with different numbers (e.g. in PRBs with different indices). The offset may be configurable.

The offset may be signaled by dedicated RRC signaling, by SI signaling or by DCI signaling. Alternatively, the offset may be derived from other signaled parameters (e.g.

the configuration of the CoMP measurement set/transmission points such as BW, center frequency, etc.).

The offset may be defined to have a granularity of one PRB and take positive values (although negative offset values are not excluded) within the range from 0 to $N_{RB}^{\max, DL} - N_{RB}^{\min, DL}$ or to $N_{RB}^{DL} - N_{RB}^{\min, DL}$. For example, offset values $\{0, \frac{1}{2}(N_{RB2}^{DL} - N_{RB1}^{DL}), N_{RB2}^{DL} - N_{RB1}^{DL}\}$ corresponding to lower frequency edge aligned cells, frequency center aligned cells and upper frequency edge aligned cells, respectively, may be used.

$N_{RB}^{\max, DL}$ represents the largest downlink bandwidth configuration, $N_{RB}^{\min, DL}$ represents the smallest downlink bandwidth configuration and N_{RB}^{DL} represents the downlink bandwidth configuration. These values may be expressed in multiples of N_{sc}^{RB} which represents the resource block size in the frequency domain in numbers of subcarriers. See 3GPP TS 36.211 § 3.1 (Exhibit F). N_{RB1}^{DL} and N_{RB2}^{DL} represent bandwidths of transmission points expressed in PRBs.

Figure 6 illustrates exemplary URS sequences for different bandwidths (BW) in accordance with this invention. Cells 610 are two lower frequency edge aligned cells where the offset has a value of 0. Cells 620 are two center frequency aligned cells where the offset has a value of half the difference between the BWs of the cells. Cells 630 are two upper frequency edge aligned cells where the offset has a value of the difference between the BWs of the cells.

Various exemplary embodiments in accordance with this invention may use a URS sequence mapping equation such as:

$$a_{k,l}^{(p)} = s \cdot r(3 \cdot l' \cdot N_{RB}^{\max, DL} + 3 \cdot (n_{PRB} + n_{PRBoffset}) + m')$$

where $a_{k,l}^{(p)}$ is a value of resource element (k,l) for antenna port p , where s is sign (e.g., determined by the orthogonal code), where $r(x)$ is the x^{th} element in the scrambling sequence, where l' is a URS-bearing OFDM symbol index, where $N_{RB}^{\max, DL}$ is the size of the largest downlink bandwidth, where n_{PRB} is the physical resource block number, where $n_{PRBoffset}$ is the PRB number/index offset, and where m' is a URS frequency-domain resource element index within a PRB.

UEs may be informed of the frequency subband of cells in a measurement set such that the UE may measure and report channel state information (CSI) measurements. The information provided may include the width and location of the CSI subband to be measured. The CSI bandwidth may be equal to the full cell's BW.

In situations where the transmission points have different BW and are center aligned, the max number of PRBs, supporting JP MU-CoMP based on CDMed DRS, may be set as the number of the PRBs (N_{RB}^{DL}) of the cell with the lowest BW. Alternatively, in situations where the transmission points are not center aligned, the max number of PRBs, supporting JP MU-CoMP based on CDMed DRS, may be set as half of the PRBs of the cell with the lowest BW due to the DC subcarrier. Setting the max number of PRBs accordingly ensures that the system can provide JP CoMP.

Figures 7 and 8 illustrate an exemplary scrambling sequence mapping in accordance with this invention. Figure 7 illustrates a scrambling sequence mapping for two PRBs. Figure 8 illustrates a scrambling sequence mapping for one PRBs where the offset is 1 PRB.

Based on the foregoing it should be apparent that the exemplary embodiments of this invention provide a method, apparatus and computer program(s) for mapping of reference signals for multi-cell transmission. Using the described reference signals mapping, JP CoMP can be supported where the transmission points have different BWs or where the participating transmission points have different relative placements of the center frequencies.

Figure 9 is a logic flow diagram that illustrates the operation of a method, and a result of execution of computer program instructions, in accordance with the exemplary embodiments of this invention. In accordance with these exemplary embodiments a method performs, at Block 910, a step of generating a reference signal sequence for at least two cells, where each cell of the at least two cells has a cell bandwidth. The method performs determining an offset for the reference signal sequence based at least

in part on the cell bandwidth (and/or on the BW location) of each cell at Block 920. At Block 930, the method includes mapping the reference signal sequence to resource elements of physical resource blocks for the cells based at least in part on the offset.

The various blocks shown in Figure 6 may be viewed as method steps, and/or as operations that result from operation of computer program code, and/or as a plurality of coupled logic circuit elements constructed to carry out the associated function(s).

An exemplary embodiment in accordance with this invention is a method for mapping of RSs. The method includes generating a RS sequence for two or more cells, where each cell of the two or more cells has a cell BW. The method also includes determining an offset for the RS sequence based at least in part on the cell BW (and/or on the BW location) of each cell. Mapping the RS sequence to REs of PRBs for the cells based at least in part on the offset is included in the method.

In a further exemplary embodiment of the method above, determining the offset includes assigning the offset a value representing one of: zero, one half the difference between the BWs of the cells, the difference between the BWs of the cells.

In an additional exemplary embodiment of any one of the methods above, determining the offset includes determining whether the two or more cells are one of: center aligned, lower frequency edge aligned and upper frequency edge aligned.

In a further exemplary embodiment of any one of the methods above, a cell BW of a first cell of the two or more cells is not equal to a cell BW of a second cell of the two or more cells.

In an additional exemplary embodiment of any one of the methods above, the method also includes sending instruction to one or more UEs to measure a CSI subband. The instructions may include width information and location information of the CSI subband. The method may also include, in response to sending the instructions, transmitting CSI measurement results.

In a further exemplary embodiment of any one of the methods above, the method also includes transmitting the offset.

In an additional exemplary embodiment of any one of the methods above, transmitting the offset includes using RRC channel signaling, DCI signaling and/or SI

signaling.

In a further exemplary embodiment of any one of the methods above, the reference signal sequence is a JP CoMP RS sequence.

In an additional exemplary embodiment of any one of the methods above, the RS sequence is a DL UE specific RS sequence for CoMP.

In a further exemplary embodiment of any one of the methods above, the offset is a frequency offset.

An additional exemplary embodiment in accordance with this invention is a computer readable medium tangibly encoded with a computer program executable by a processor to perform actions for mapping of RSs. The actions include generating a RS sequence for two or more cells, where each cell of the two or more cells has a cell BW. The actions also include determining an offset for the RS sequence based at least in part on the cell BW (and/or on the BW location) of each cell. Mapping the RS sequence to REs of PRBs for the cells based at least in part on the offset is included in the actions.

In a further exemplary embodiment of the computer readable medium above, determining the offset includes assigning the offset a value representing one of: zero, one half the difference between the BWs of the cells, the difference between the BWs of the cells.

In an additional exemplary embodiment of any one of the computer readable media above, determining the offset includes determining whether the two or more cells are one of: center aligned, lower frequency edge aligned and upper frequency edge aligned.

In a further exemplary embodiment of any one of the computer readable media above, a cell BW of a first cell of the two or more cells is not equal to a cell BW of a second cell of the two or more cells.

In an additional exemplary embodiment of any one of the computer readable media above, the actions also include sending instruction to one or more UEs to measure a CSI subband. The instructions may include width information and location information of the CSI subband. The actions may also include, in response to sending the instructions, transmitting CSI measurement results.

In a further exemplary embodiment of any one of the computer readable media above, the actions also include transmitting the offset.

In an additional exemplary embodiment of any one of the computer readable media above, transmitting the offset includes using RRC channel signaling, DCI signaling and/or SI signaling.

In a further exemplary embodiment of any one of the computer readable media above, the reference signal sequence is a JP CoMP RS sequence.

In an additional exemplary embodiment of any one of the computer readable media above, the RS sequence is a DL UE specific RS sequence for CoMP.

In a further exemplary embodiment of any one of the computer readable media above, the offset is a frequency offset.

An additional exemplary embodiment in accordance with this invention is an apparatus for mapping of RSs. The apparatus includes at least one processor; and at least one memory including computer program code. The at least one memory and the computer program code are configured to, with the at least one processor, cause the apparatus to perform operations. The operations include to generate a RS sequence for two or more cells, where each cell of the two or more cells has a cell BW. The operations also include to determine an offset for the RS sequence based at least in part on the cell BW (and/or on the BW location) of each cell. To mapping the RS sequence to REs of PRBs for the cells based at least in part on the offset is included in the operations.

In a further exemplary embodiment of the apparatus above, when determining the offset the operations include to assign the offset a value representing one of: zero, one half the difference between the BWs of the cells, the difference between the BWs of the cells.

In an additional exemplary embodiment of any one of the apparatus above, when determining the offset the operations include to determine whether the two or more cells are one of: center aligned, lower frequency edge aligned and upper frequency edge aligned.

In a further exemplary embodiment of any one of the apparatus above, a cell BW of a first cell of the two or more cells is not equal to a cell BW of a second cell of the two or more cells.

In an additional exemplary embodiment of any one of the apparatus above, the

operations also include to send instruction to one or more UEs to measure a CSI subband. The instructions may include width information and location information of the CSI subband. The operations may also include, in response to sending the instructions, to transmit CSI measurement results.

In a further exemplary embodiment of any one of the apparatus above, the operations also include to transmit the offset.

In an additional exemplary embodiment of any one of the apparatus above, when transmitting the offset the operations include to use RRC channel signaling, DCI signaling and/or SI signaling.

In a further exemplary embodiment of any one of the apparatus above, the reference signal sequence is a JP CoMP RS sequence.

In an additional exemplary embodiment of any one of the apparatus above, the RS sequence is a DL UE specific RS sequence for CoMP.

In a further exemplary embodiment of any one of the apparatus above, the offset is a frequency offset.

An additional exemplary embodiment in accordance with this invention is a apparatus for mapping of RSs. The apparatus includes means for generating (e.g., a processor) a RS sequence for two or more cells, where each cell of the two or more cells has a cell BW. The apparatus also includes means for determining (e.g., a processor) an offset for the RS sequence based at least in part on the cell BW (and/or on the BW location) of each cell. Means for mapping (e.g., a processor) the RS sequence to REs of PRBs for the cells based at least in part on the offset is included in the apparatus.

In a further exemplary embodiment of the apparatus above, the determining means include means for assigning (e.g., a processor) the offset a value representing one of: zero, one half the difference between the BWs of the cells, the difference between the BWs of the cells.

In an additional exemplary embodiment of any one of the apparatus above, the determining means include means for determining (e.g., a processor) whether the two or more cells are one of: center aligned, lower frequency edge aligned and upper frequency edge aligned.

In a further exemplary embodiment of any one of the apparatus above, a cell BW of a first cell of the two or more cells is not equal to a cell BW of a second cell of the two or more cells.

In an additional exemplary embodiment of any one of the apparatus above, the apparatus also includes means for sending (e.g., a transmitter) instruction to one or more UEs to measure a CSI subband. The instructions may include width information and location information of the CSI subband. The apparatus may also include means for transmitting (e.g., a transmitter) CSI measurement results in response to sending the instructions.

In a further exemplary embodiment of any one of the apparatus above, the apparatus also includes means for transmitting (e.g., a transmitter) the offset.

In an additional exemplary embodiment of any one of the apparatus above, the transmitting means include means for using (e.g., a transmitter) RRC channel signaling, DCI signaling and/or SI signaling.

In a further exemplary embodiment of any one of the apparatus above, the reference signal sequence is a JP CoMP RS sequence.

In an additional exemplary embodiment of any one of the apparatus above, the RS sequence is a DL UE specific RS sequence for CoMP.

In a further exemplary embodiment of any one of the apparatus above, the offset is a frequency offset.

In general, the various exemplary embodiments may be implemented in hardware or special purpose circuits, software, logic or any combination thereof. For example, some aspects may be implemented in hardware, while other aspects may be implemented in firmware or software which may be executed by a controller, microprocessor or other computing device, although the invention is not limited thereto. While various aspects of the exemplary embodiments of this invention may be illustrated and described as block diagrams, flow charts, or using some other pictorial representation, it is well understood that these blocks, apparatus, systems, techniques or methods described herein may be implemented in, as nonlimiting examples, hardware, software, firmware, special purpose circuits or logic, general purpose hardware or controller or other computing devices, or some combination thereof.

It should thus be appreciated that at least some aspects of the exemplary embodiments of the inventions may be practiced in various components such as integrated circuit chips and modules, and that the exemplary embodiments of this invention may be realized in an apparatus that is embodied as an integrated circuit. The integrated circuit, or circuits, may comprise circuitry (as well as possibly firmware) for embodying at least one or more of a data processor or data processors, a digital signal processor or processors, baseband circuitry and radio frequency circuitry that are configurable so as to operate in accordance with the exemplary embodiments of this invention.

Various modifications and adaptations to the foregoing exemplary embodiments of this invention may become apparent to those skilled in the relevant arts in view of the foregoing description, when read in conjunction with the accompanying drawings. However, any and all modifications will still fall within the scope of the non-limiting and exemplary embodiments of this invention.

For example, while the exemplary embodiments have been described above in the context of the E-UTRAN (UTRAN-LTE) system, it should be appreciated that the exemplary embodiments of this invention are not limited for use with only this one particular type of wireless communication system, and that they may be used to advantage in other wireless communication systems such as for example (WLAN, UTRAN, GSM as appropriate).

It should be noted that the terms "connected," "coupled," or any variant thereof, mean any connection or coupling, either direct or indirect, between two or more elements, and may encompass the presence of one or more intermediate elements between two elements that are "connected" or "coupled" together. The coupling or connection between the elements can be physical, logical, or a combination thereof. As employed herein two elements may be considered to be "connected" or "coupled" together by the use of one or more wires, cables and/or printed electrical connections, as well as by the use of electromagnetic energy, such as electromagnetic energy having

wavelengths in the radio frequency region, the microwave region and the optical (both visible and invisible) region, as several non-limiting and non-exhaustive examples.

Further, the various names used for the described parameters (e.g., PRB, RRC, UE, etc.) are not intended to be limiting in any respect, as these parameters may be identified by any suitable names. Further, the formulas and expressions that use these various parameters may differ from those expressly disclosed herein. Further, the various names assigned to different channels (e.g., RRC, etc.) are not intended to be limiting in any respect, as these various channels may be identified by any suitable names.

Furthermore, some of the features of the various non-limiting and exemplary embodiments of this invention may be used to advantage without the corresponding use of other features. As such, the foregoing description should be considered as merely illustrative of the principles, teachings and exemplary embodiments of this invention, and not in limitation thereof.

WHAT IS CLAIMED IS:

1. A method comprising:
 - generating a reference signal sequence for at least two cells, where each cell of the at least two cells has a cell bandwidth;
 - determining an offset for the reference signal sequence based at least in part on the cell bandwidth of each cell; and
 - mapping the reference signal sequence to resource elements of physical reference blocks for the cells based at least in part on the offset.
2. The method of claim 1, where determining the offset comprises assigning the offset a value representing half a difference between the bandwidths of the at least two cells.
3. The method of claim 1, where determining the offset comprises assigning the offset a value representing a difference between the bandwidths of the at least two cells.
4. The method of any one of claims 1-3, where determining the offset comprises determining whether the at least two cells are one of: center aligned, lower frequency edge aligned and upper frequency edge aligned.
5. The method of any one of claims 1-4, where a cell bandwidth of a first cell of the at least two cells is not equal to a cell bandwidth of a second cell of the at least two cells.
6. The method of any one of claims 1-5, further comprising: sending instruction to at least one user equipment to measure a channel state information subband.
7. The method of claim 6, where the instructions comprise width information and location information of the channel state information subband.
8. The method of claim 6, further comprising, in response to sending the

instructions, transmitting channel state information measurement results.

9. The method of any one of claims 1-8, further comprising transmitting the offset.

10. The method of claim 9, where transmitting the offset comprises using at least one of: dedicated radio resource control signaling, downlink control information signaling and system information signaling.

11. The method of any one of claims 1-10, where the reference signal sequence is a joint transmission/processing coordinated multi-point transmission/reception reference signal sequence.

12. The method of any one of claims 1-11, where the reference signal sequence is a downlink user equipment specific reference signal sequence for coordinated multi-point transmission/reception.

13. The method of any one of claims 1-12, where the offset is a frequency offset.

14. An apparatus, comprising: at least one processor; and at least one memory including computer program code, the at least one memory and the computer program code configured to, with the at least one processor, cause the apparatus to perform at least the following:

to generate a reference signal sequence for at least two cells, where each cell of the at least two cells has a cell bandwidth;

to determine an offset for the reference signal sequence based at least in part on the cell bandwidth of each cell; and

to map the reference signal sequence to resource elements of physical reference blocks for the cells based at least in part on the offset.

15. The apparatus of claim 14, where the apparatus is configured, when determining the offset, to assign the offset a value representing half a difference between the bandwidths of the at least two cells.

16. The apparatus of claim 14, where the apparatus is configured, when determining the offset, to assign the offset a value representing a difference between the bandwidths of the at least two cells.

17. The apparatus of any one of claims 14-16, where the apparatus is configured, when determining the offset, to determine whether the at least two cells are one of: center aligned, lower frequency edge aligned and upper frequency edge aligned.

18. The apparatus of any one of claims 14-17, where a cell bandwidth of a first cell of the at least two cells is not equal to a cell bandwidth of a second cell of the at least two cells.

19. The apparatus of any one of claims 14-18, where the at least one memory and the computer program code are further configured to, with the at least one processor, cause the apparatus: to send instruction to at least one user equipment to measure a channel state information subband.

20. The apparatus of claim 19, where the instructions comprise width information and location information of the channel state information subband.

21. The apparatus of claim 19, where the at least one memory and the computer program code are further configured to, with the at least one processor, cause the apparatus: to transmit channel state information measurement results in response to sending the instructions.

22. The apparatus of any one of claims 14-21, where the at least one memory and the computer program code are further configured to, with the at least one processor, cause the apparatus: to transmit the offset.

23. The apparatus of claim 22, where the apparatus is configured, when transmitting the offset, to use at least one of: dedicated radio resource control signaling, downlink

control information signaling and system information signaling.

24. The apparatus of any one of claims 14-23, where the reference signal sequence is a joint transmission/processing coordinated multi-point transmission/reception reference signal sequence.

25. The apparatus of any one of claims 14-24, where the reference signal sequence is a downlink user equipment specific reference signal sequence for coordinated multi-point transmission/reception.

26. The apparatus of any one of claims 14-25, where the offset is a frequency offset.

27. A computer readable medium tangibly encoded with a computer program executable by a processor to perform actions comprising:

generating a reference signal sequence for at least two cells, where each cell of the at least two cells has a cell bandwidth;

determining an offset for the reference signal sequence based at least in part on the cell bandwidth of each cell; and

mapping the reference signal sequence to resource elements of physical reference blocks for the cells based at least in part on the offset.

28. The computer readable medium of claim 27, where determining the offset comprises assigning the offset a value representing half a difference between the bandwidths of the at least two cells.

29. The computer readable medium of claim 27, where determining the offset comprises assigning the offset a value representing a difference between the bandwidths of the at least two cells.

30. The computer readable medium of any one of claims 27-29, where determining the offset comprises determining whether the at least two cells are one of: center aligned, lower frequency edge aligned and upper frequency edge aligned.

31. The computer readable medium of any one of claims 27-30, where a cell bandwidth of a first cell of the at least two cells is not equal to a cell bandwidth of a second cell of the at least two cells.

32. The computer readable medium of any one of claims 27-31, where the actions further comprise: sending instruction to at least one user equipment to measure a channel state information subband.

33. The computer readable medium of claim 32, where the instructions comprise width information and location information of the channel state information subband.

34. The computer readable medium of claim 32, where the actions further comprise, in response to sending the instructions, transmitting channel state information measurement results.

35. The computer readable medium of any one of claims 27-34, where the actions further comprise transmitting the offset.

36. The computer readable medium of claim 35, where transmitting the offset comprises using at least one of: dedicated radio resource control signaling, downlink control information signaling and system information signaling.

37. The computer readable medium of any one of claims 27-36, where the reference signal sequence is a joint transmission/processing coordinated multi-point transmission/reception reference signal sequence.

38. The computer readable medium of any one of claims 27-37, where the reference signal sequence is a downlink user equipment specific reference signal sequence for coordinated multi-point transmission/reception.

39. The computer readable medium of any one of claims 27-38, where the offset is a

frequency offset.

40. An apparatus, comprising:

means for generating a reference signal sequence for at least two cells, where each cell of the at least two cells has a cell bandwidth;

means for determining an offset for the reference signal sequence based at least in part on the cell bandwidth of each cell; and

means for mapping the reference signal sequence to resource elements of physical reference blocks for the cells based at least in part on the offset.

41. The apparatus of claim 40, where the determining means comprises means for assigning the offset a value representing half a difference between the bandwidths of the at least two cells.

42. The apparatus of claim 40, where the determining means comprises means for assigning the offset a value representing a difference between the bandwidths of the at least two cells.

43. The apparatus of any one of claims 40-42, where the determining means comprises means for determining whether the at least two cells are one of: center aligned, lower frequency edge aligned and upper frequency edge aligned.

44. The apparatus of any one of claims 40-43, where a cell bandwidth of a first cell of the at least two cells is not equal to a cell bandwidth of a second cell of the at least two cells.

45. The apparatus of any one of claims 40-44, further comprising: means for sending instruction to at least one user equipment to measure a channel state information subband.

46. The apparatus of claim 45, where the instructions comprise width information and location information of the channel state information subband.

47. The apparatus of claim 45, further comprising means for transmitting channel state information measurement results in response to sending the instructions.

48. The apparatus of any one of claims 40-47, further comprising means for transmitting the offset.

49. The apparatus of claim 48, where the transmitting means comprises means for using at least one of: dedicated radio resource control signaling, downlink control information signaling and system information signaling.

50. The apparatus of any one of claims 40-49, where the reference signal sequence is a joint transmission/processing coordinated multi-point transmission/reception reference signal sequence.

51. The apparatus of any one of claims 40-50, where the reference signal sequence is a downlink user equipment specific reference signal sequence for coordinated multi-point transmission/reception.

52. The apparatus of any one of claims 40-51, where the offset is a frequency offset.

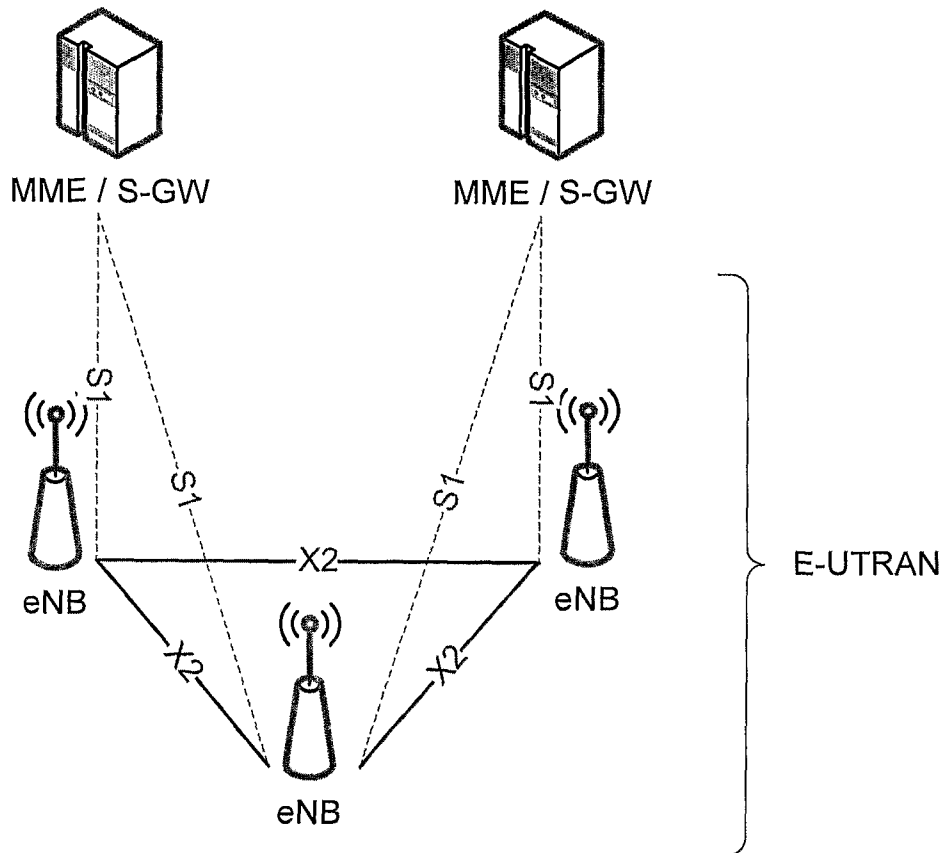
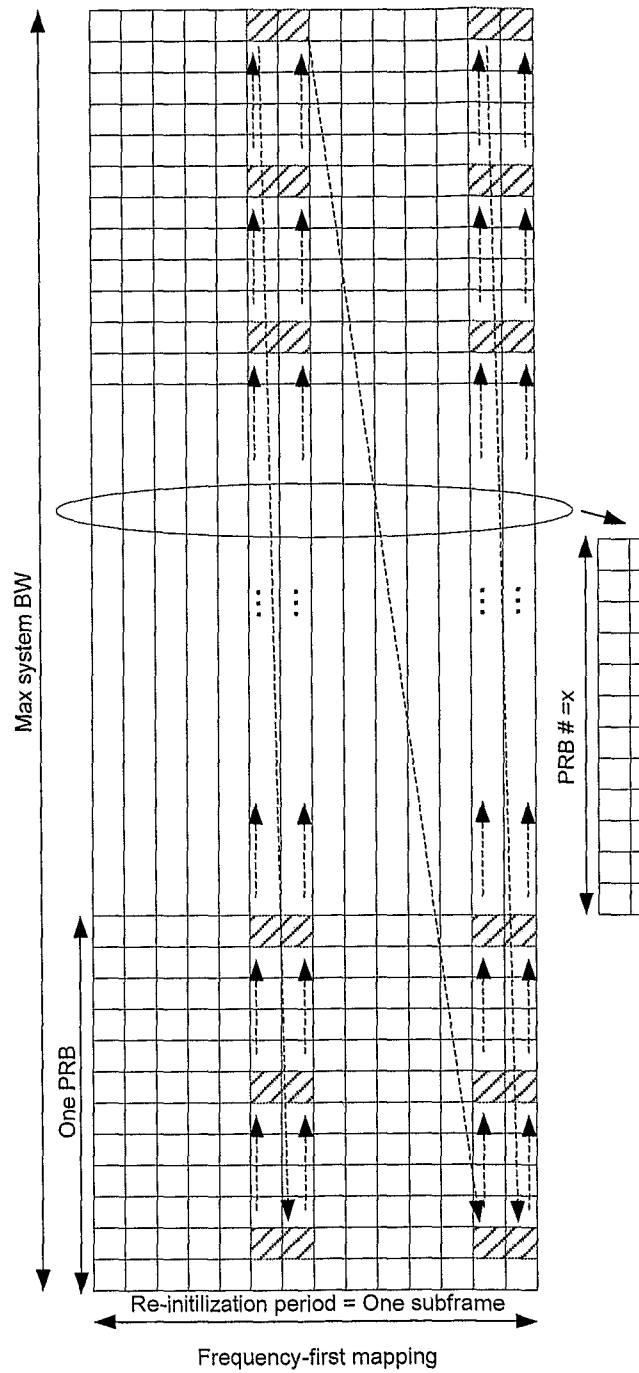

Figure 1 (Prior Art)



To Fig. 2b

Figure 2a (Prior Art)

To Fig. 2a

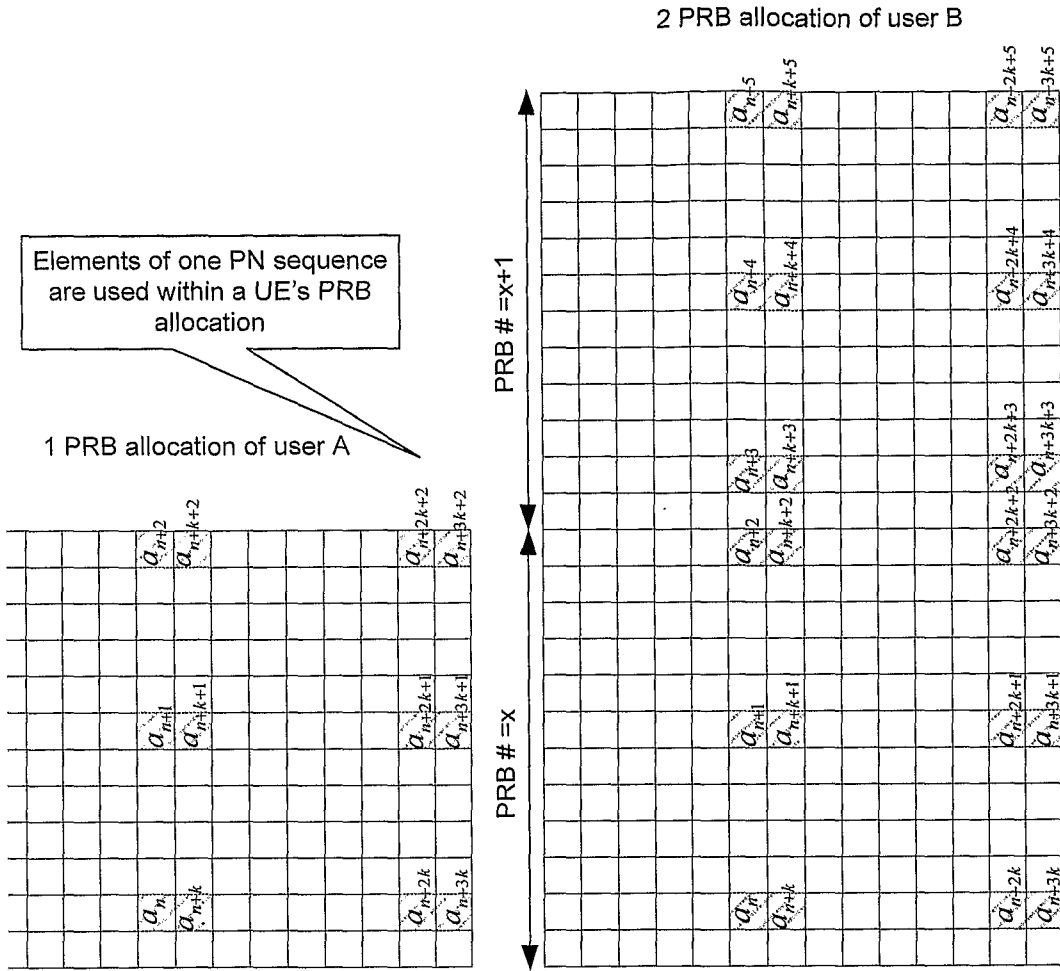

a_n n -th symbol of the scrambling sequence
 (a bit pair of the scrambling sequence due QPSK scrambling)

k number of URS REs in a DRS-bearing OFDM symbol
 assuming max. system BW

 URS RE

 Order of URS sequence mapping

Figure 2b (Prior Art)

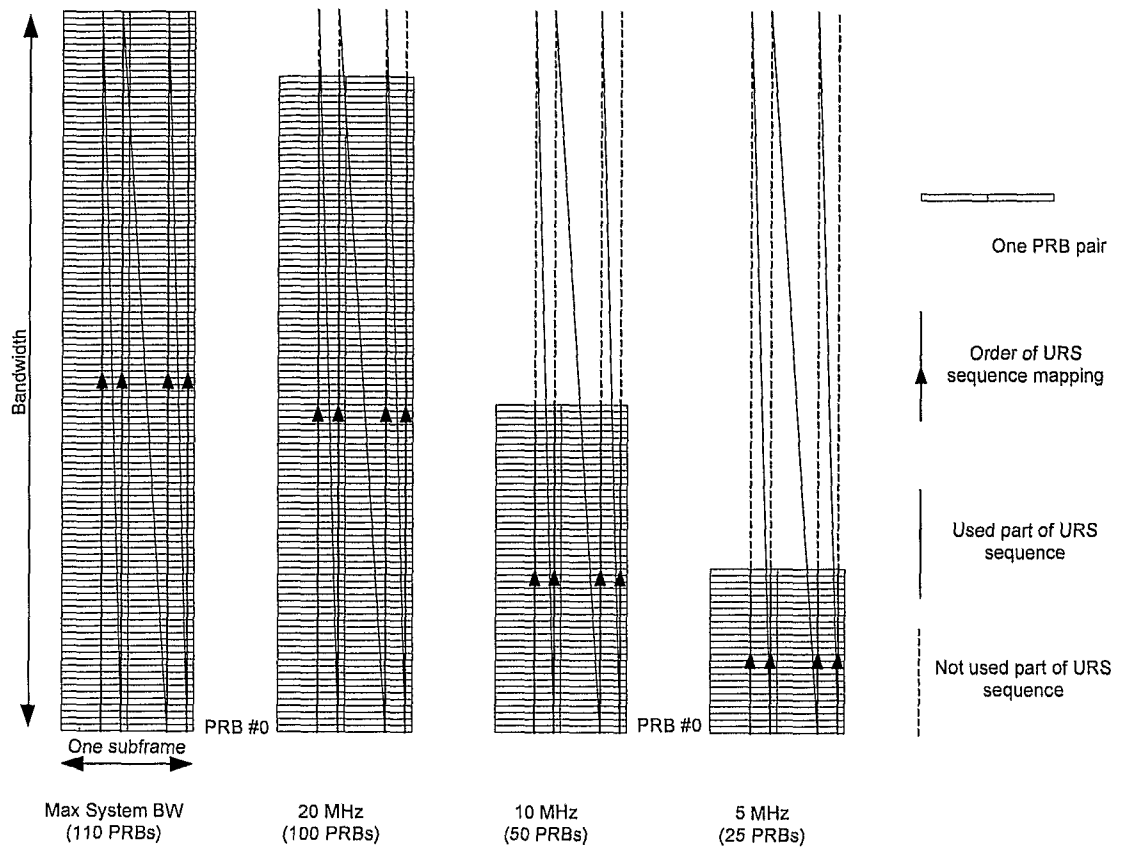

Figure 3 (Prior Art)

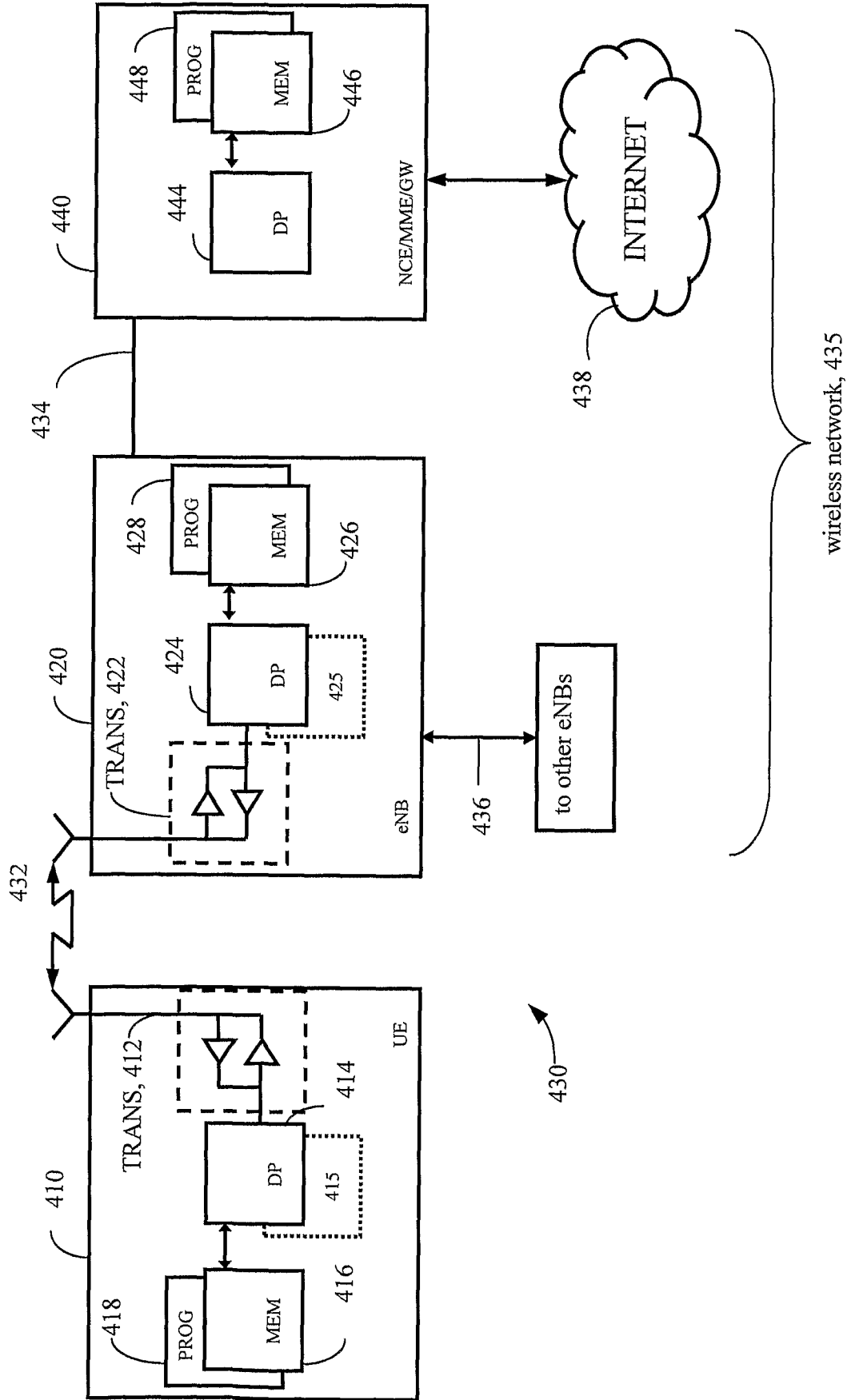

Figure 4

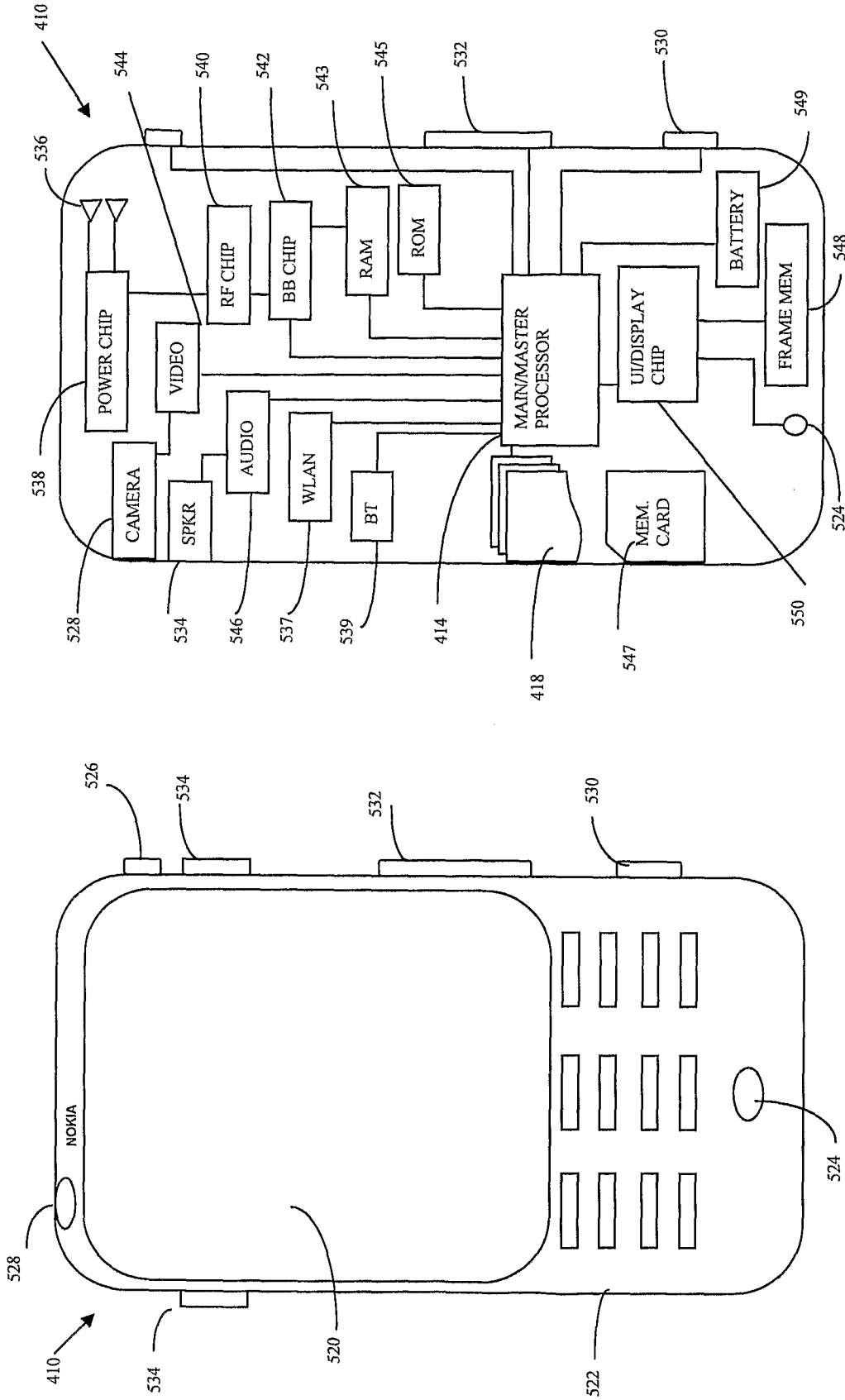

Figure 5

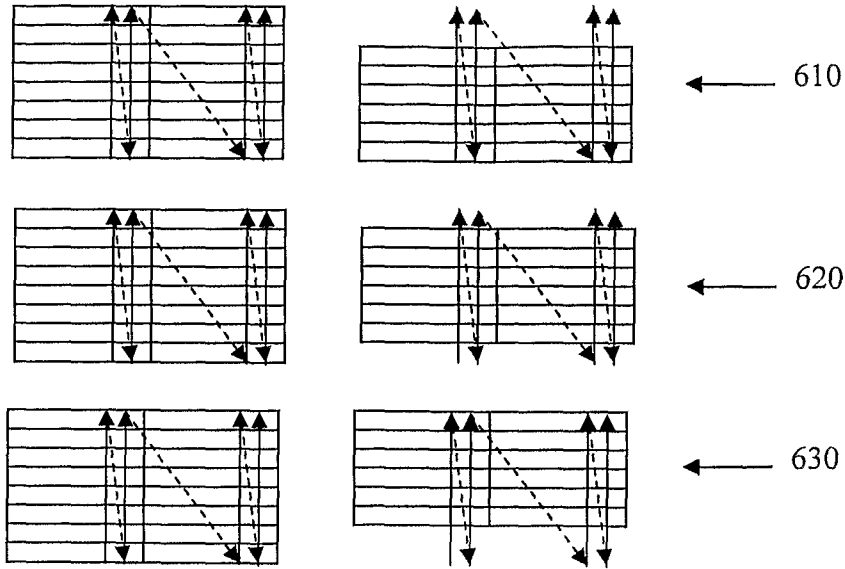

Figure 6

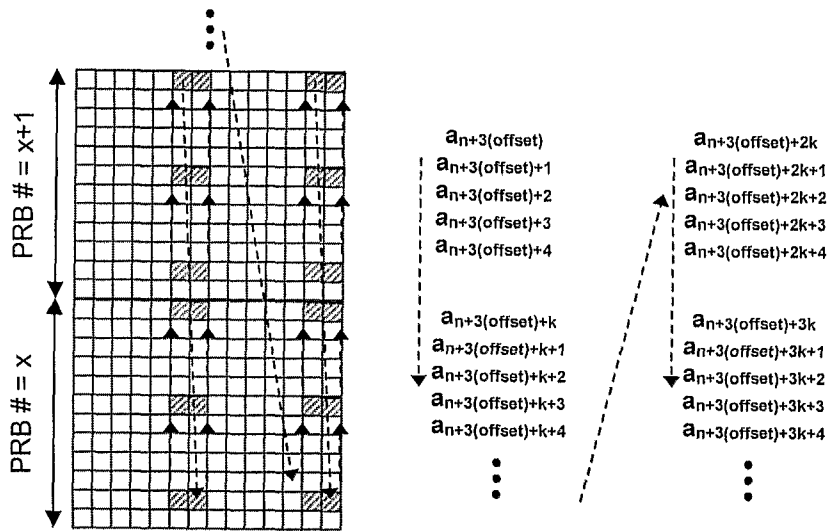

Figure 7

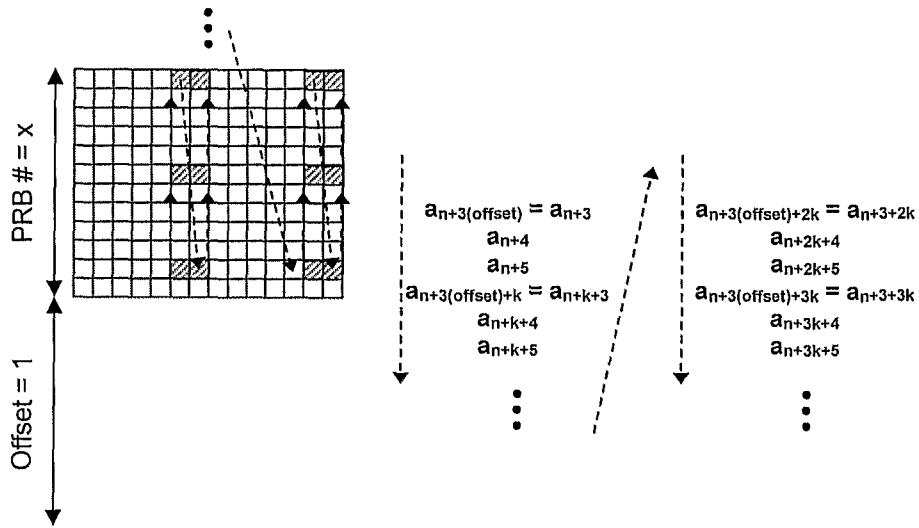

Figure 8

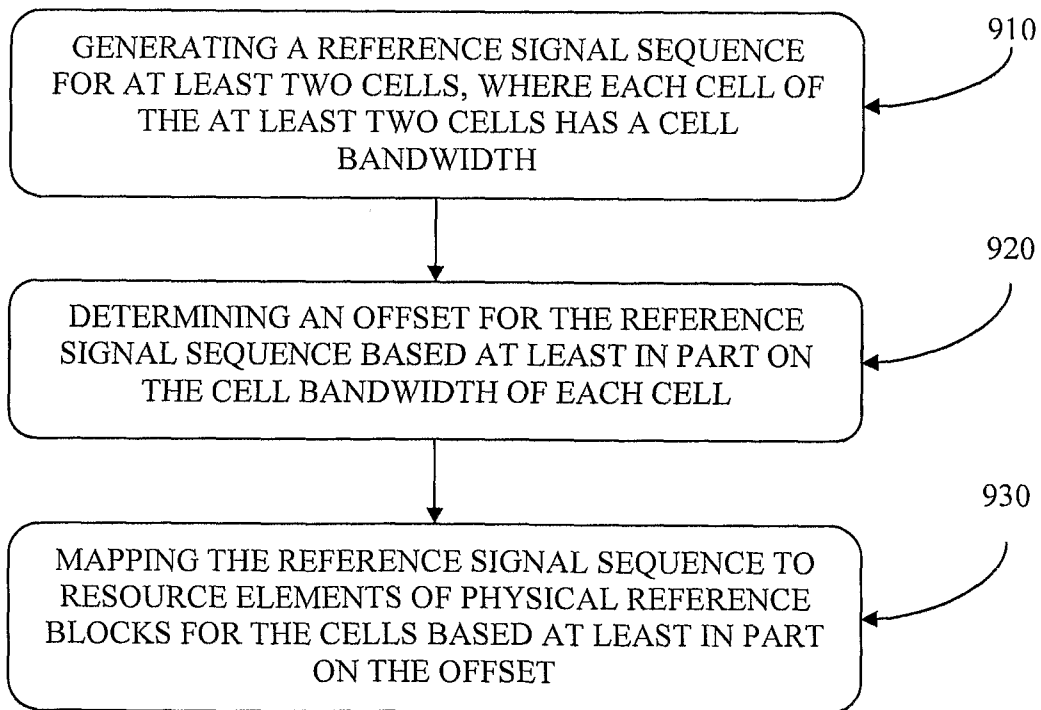

Figure 9

INTERNATIONAL SEARCH REPORT

International application No.
PCT/CN2009/076048

A. CLASSIFICATION OF SUBJECT MATTER

See the extra sheet

According to International Patent Classification (IPC) or to both national classification and IPC

B. FIELDS SEARCHED

Minimum documentation searched (classification system followed by classification symbols)

IPC: H04L H04W H04Q H04B

Documentation searched other than minimum documentation to the extent that such documents are included in the fields searched

Electronic data base consulted during the international search (name of data base and, where practicable, search terms used)

WPI,EPODOC,CNPAT,CNKI: reference, signal, cell, bandwidth, offset, shift, different

C. DOCUMENTS CONSIDERED TO BE RELEVANT

Category*	Citation of document, with indication, where appropriate, of the relevant passages	Relevant to claim No.
A	3GPP TSG RAN WG1 #58bis Meeting R1- 093890, "Consideration on initialization and mapping of DM-RS sequence", 12-16 Oct. 2009 (12-16.10.2009), pages 1-3	1-52
A	3GPP TS 36.211 v 8.9.0, "Evolved Universal Terrestrial Radio Access (E-UTRA); Physical Channels and Modulation", 16 Dec. 2009 (16.12.2009), the whole document	1-52
A	WO 2008/094022 A1 (LG ELECTRONICS INC.), 07 Aug. 2008 (07.08.2008), the whole document	1-52
A	WO 2008/093716 A1 (MATSUSHITA ELECTRIC INDUSTRIAL CO., LTD.), 07 Aug. 2008 (07.08.2008), the whole document	1-52
A	CN 101267664 A (HUAWEI TECHNOLOGIES CO., LTD.), 17 Sep. 2008 (17.09.2008), the whole document	1-52
A	CN 101500242 A (DA TANG MOBILE COMMUNICATION EQUIPMENT CO., LTD.), 05 Aug. 2009 (05.08.2009), the whole document	1-52

Further documents are listed in the continuation of Box C. See patent family annex.

<p>* Special categories of cited documents:</p> <p>"A" document defining the general state of the art which is not considered to be of particular relevance</p> <p>"E" earlier application or patent but published on or after the international filing date</p> <p>"L" document which may throw doubts on priority claim (S) or which is cited to establish the publication date of another citation or other special reason (as specified)</p> <p>"O" document referring to an oral disclosure, use, exhibition or other means</p> <p>"P" document published prior to the international filing date but later than the priority date claimed</p>	<p>"T" later document published after the international filing date or priority date and not in conflict with the application but cited to understand the principle or theory underlying the invention</p> <p>"X" document of particular relevance; the claimed invention cannot be considered novel or cannot be considered to involve an inventive step when the document is taken alone</p> <p>"Y" document of particular relevance; the claimed invention cannot be considered to involve an inventive step when the document is combined with one or more other such documents, such combination being obvious to a person skilled in the art</p> <p>"&" document member of the same patent family</p>
--	---

Date of the actual completion of the international search 10 Sep. 2010 (10.09.2010)	Date of mailing of the international search report 08 Oct. 2010 (08.10.2010)
---	--

Name and mailing address of the ISA/CN
The State Intellectual Property Office, the P.R.China
6 Xitucheng Rd., Jimen Bridge, Haidian District, Beijing, China
100088
Facsimile No. 86-10-62019451

Authorized officer
YANG Jiaoyu
Telephone No. (86-10)62413301

INTERNATIONAL SEARCH REPORT
Information on patent family members

International application No.
PCT/CN2009/076048

Patent Documents referred in the Report	Publication Date	Patent Family	Publication Date
WO 2008/094022 A1	07.08.2008	KR20080072500A	06.08.2008
		US2010/0008333A1	14.01.2010
WO 2008/093716 A1	07.08.2008	EP2120353A1	18.11.2009
		US2010/0002804A1	07.01.2010
		JP2008556139T2	20.05.2010
CN 101267664 A	17.09.2008	NONE	
CN 101500242 A	05.08.2009	NONE	

INTERNATIONAL SEARCH REPORT

International application No.

PCT/CN2009/076048

Continuation of : CLASSIFICATION OF SUBJECT MATTER

H04W 16/02 (2009.01) i

H04B 7/26 (2006.01) i