



(51) International Patent Classification:

G06F 3/0488 (2013.01) G06F 3/0484 (2013.01)  
G06F 3/0482 (2013.01) G06F 3/0486 (2013.01)  
G06F 3/0485 (2013.01)

(21) International Application Number:

PCT/US2013/033762

(22) International Filing Date:

25 March 2013 (25.03.2013)

(25) Filing Language:

English

(26) Publication Language:

English

(30) Priority Data:

61/615,316 25 March 2012 (25.03.2012) US  
61/615,307 25 March 2012 (25.03.2012) US  
61/615,876 26 March 2012 (26.03.2012) US

(71) Applicant: MASIMO CORPORATION [US/US]; 40 Parker, Irvine, CA 92618 (US).

(72) Inventors: AL-ALI, Ammar; 30312 Via Bella, San Juan Capistrano, CA 92675 (US). MUHSIN, Bilal; 43 Via Tor-

ina, San Clemente, CA 92673 (US). INDORF, Keith, Ward; 10606 Portsmouth Ct., Riverside, CA 92503 (US).

(74) Agent: CHRISTENSEN, Michael R.; 2040 Main Street, 14th Floor, Irvine, CA 92614 (US).

(81) Designated States (unless otherwise indicated, for every kind of national protection available): AE, AG, AL, AM, AO, AT, AU, AZ, BA, BB, BG, BH, BN, BR, BW, BY, BZ, CA, CH, CL, CN, CO, CR, CU, CZ, DE, DK, DM, DO, DZ, EC, EE, EG, ES, FI, GB, GD, GE, GH, GM, GT, HN, HR, HU, ID, IL, IN, IS, JP, KE, KG, KM, KN, KP, KR, KZ, LA, LC, LK, LR, LS, LT, LU, LY, MA, MD, ME, MG, MK, MN, MW, MX, MY, MZ, NA, NG, NI, NO, NZ, OM, PA, PE, PG, PH, PL, PT, QA, RO, RS, RU, RW, SC, SD, SE, SG, SK, SL, SM, ST, SV, SY, TH, TJ, TM, TN, TR, TT, TZ, UA, UG, US, UZ, VC, VN, ZA, ZM, ZW.

(84) Designated States (unless otherwise indicated, for every kind of regional protection available): ARIPO (BW, GH, GM, KE, LR, LS, MW, MZ, NA, RW, SD, SL, SZ, TZ, UG, ZM, ZW), Eurasian (AM, AZ, BY, KG, KZ, RU, TJ, TM), European (AL, AT, BE, BG, CH, CY, CZ, DE, DK,

[Continued on next page]

(54) Title: PHYSIOLOGICAL MONITOR TOUCHSCREEN INTERFACE

(57) Abstract: A physiological monitor touchscreen interface presents interface constructs on a touchscreen display that are particularly adapted to finger gestures so to change at least one of a physiological monitor operating characteristic and a physiological touchscreen display characteristic.

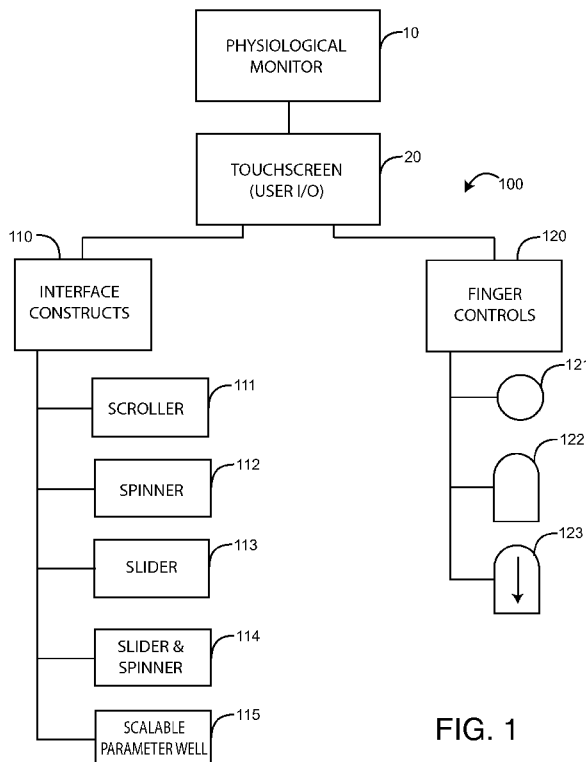

FIG. 1

WO 2013/148605 A1

EE, ES, FI, FR, GB, GR, HR, HU, IE, IS, IT, LT, LU, **Published:**  
LV, MC, MK, MT, NL, NO, PL, PT, RO, RS, SE, SI, SK, — *with international search report (Art. 21(3))*  
SM, TR), OAPI (BF, BJ, CF, CG, CI, CM, GA, GN, GQ,  
GW, ML, MR, NE, SN, TD, TG).

## PHYSIOLOGICAL MONITOR TOUCHSCREEN INTERFACE

### CROSS-REFERENCE TO RELATED APPLICATIONS

[0001] The present application claims priority benefit under 35 U.S.C. § 119(e) to U.S. Provisional Patent Application Serial No. 61/615,307, filed 03/25/2012, titled *Physiological Monitor User Controls*; U.S. Provisional Patent Application Serial No. 61/615,316, filed 03/25/2012, titled *Physiological Monitor User Interface*; and U.S. Provisional Patent Application Serial No. 61/615,876, filed 03/26/2012, titled *Physiological Monitor Touchscreen*; all of the above referenced applications are hereby incorporated in their entireties by reference herein.

### BACKGROUND OF THE INVENTION

[0002] Pulse oximetry is a widely accepted noninvasive procedure for measuring the oxygen saturation level of arterial blood, an indicator of a person's oxygen supply. A typical pulse oximetry system utilizes an optical sensor attached to a fingertip to measure the relative volume of oxygenated hemoglobin in pulsatile arterial blood flowing within the fingertip. Oxygen saturation ( $SpO_2$ ), pulse rate and a plethysmograph waveform, which is a visualization of pulsatile blood flow over time, are displayed on a monitor accordingly.

[0003] Conventional pulse oximetry assumes that arterial blood is the only pulsatile blood flow in the measurement site. During patient motion, venous blood also moves, which causes errors in conventional pulse oximetry. Advanced pulse oximetry processes the venous blood signal so as to report true arterial oxygen saturation and pulse rate under conditions of patient movement. Advanced pulse oximetry also functions under conditions of low perfusion (small signal amplitude), intense ambient light (artificial or sunlight) and electrosurgical instrument interference, which are scenarios where conventional pulse oximetry tends to fail.

[0004] Advanced pulse oximetry is described in at least U.S. Pat. Nos. 6,770,028; 6,658,276; 6,157,850; 6,002,952; 5,769,785 and 5,758,644, which are assigned to Masimo Corporation ("Masimo") of Irvine, California and are incorporated in their entirety by reference herein. Corresponding low noise optical sensors are disclosed in at least U.S. Pat. Nos. 6,985,764; 6,813,511;

6,792,300; 6,256,523; 6,088,607; 5,782,757 and 5,638,818, which are also assigned to Masimo and are also incorporated in their entirety by reference herein. Advanced pulse oximetry systems including Masimo SET<sup>®</sup> low noise optical sensors and read through motion pulse oximetry monitors for measuring SpO<sub>2</sub>, pulse rate (PR) and perfusion index (PI) are available from Masimo. Optical sensors include any of Masimo LNOP<sup>®</sup>, LNCS<sup>®</sup>, SofTouch<sup>™</sup> and Blue<sup>™</sup> adhesive or reusable sensors. Pulse oximetry monitors include any of Masimo Rad-8<sup>®</sup>, Rad-5<sup>®</sup>, Rad<sup>®</sup>-5v or SatShare<sup>®</sup> monitors.

**[0005]** Advanced blood parameter measurement systems are described in at least U.S. Pat. 7,647,083, filed March 1, 2006, titled *Multiple Wavelength Sensor Equalization*; U.S. Pat. No. 7,729,733, filed March 1, 2006, titled *Configurable Physiological Measurement System*; U.S. Pat. Pub. No. 2006/0211925, filed March 1, 2006, titled *Physiological Parameter Confidence Measure* and U.S. Pat. Pub. No. 2006/0238358, filed March 1, 2006, titled *Noninvasive Multi-Parameter Patient Monitor*, all assigned to Cercacor Laboratories, Inc., Irvine, CA (Cercacor) and all incorporated in their entirety by reference herein. Advanced blood parameter measurement systems include Masimo Rainbow<sup>®</sup> SET, which provides measurements in addition to SpO<sub>2</sub>, such as total hemoglobin (SpHb<sup>™</sup>), oxygen content (SpOC<sup>™</sup>), methemoglobin (SpMet<sup>®</sup>), carboxyhemoglobin (SpCO<sup>®</sup>) and PVI<sup>®</sup>. Advanced blood parameter sensors include Masimo Rainbow<sup>®</sup> adhesive, ReSposable<sup>™</sup> and reusable sensors. Advanced blood parameter monitors include Masimo Radical-7<sup>™</sup>, Rad-87<sup>™</sup> and Rad-57<sup>™</sup> monitors, all available from Masimo. Such advanced pulse oximeters, low noise sensors and advanced blood parameter systems have gained rapid acceptance in a wide variety of medical applications, including surgical wards, intensive care and neonatal units, general wards, home care, physical training, and virtually all types of monitoring scenarios.

### SUMMARY OF THE INVENTION

[0006] A physiological monitor touchscreen interface presents interface constructs on a touchscreen display that are particularly adapted to finger gestures so to change at least one of a physiological monitor operating characteristic and a physiological touchscreen display characteristic. The physiological monitor touchscreen interface has a first interface construct operable to select a menu item from a touchscreen display and a second interface construct operable to define values for the selected menu item.

[0007] In various embodiments, the first interface construct has a first scroller that presents a rotating set of the menu items in a touchscreen display area and a second scroller that presents a rotating set of thumbnails in a display well. The thumbnails reference the menu items and the thumbnails rotate with the menu items. The first scroller presents a rotating set of second level menu items upon selection of the menu item. The second interface construct is a slider for selecting limits for one of the second level menu items. A spinner is used in conjunction with the slider for making a first gross limit selection with the slider followed by a finer limit selection with the spinner. A parameter area displays parameter values in a full presentation format and a parameter well area displays parameter values in an abbreviated presentation format. The full presentation format is a larger font than the abbreviated presentation format. A dynamic space allocation for the parameters values is presented in the parameter area such that the more parameters there are in the parameter area and, accordingly, the fewer parameters there are in the parameter well area, then the larger the display font for the parameters in the parameter area.

BRIEF DESCRIPTION OF THE DRAWINGS

- [0008] FIG. 1 is a hierarchical chart of a physiological monitor touchscreen interface including interface constructs and finger controls;
- [0009] FIGS. 2-7 are illustrations of various touchscreen interface constructs for controlling a physiological monitor;
- [0010] FIGS. 2A-D are illustrations of a scroller;
- [0011] FIGS. 3A-C are illustrations of a physiological monitor main menu and sub-menus implemented with a scroller;
- [0012] FIGS. 4A-C are illustrations of a spinner;
- [0013] FIGS. 5A-B are illustrations of a slider;
- [0014] FIG. 6 is an illustration of a slider-spinner; and
- [0015] FIGS. 7A-D are illustrations of a parameter monitor touchscreen providing dynamic allocation of the parameter display area utilizing a parameter well.

### DETAILED DESCRIPTION OF THE PREFERRED EMBODIMENTS

[0016] **FIG. 1** illustrates a touchscreen interface 100 for a physiological monitor 10 and, in particular, for a touchscreen display 20 integral to the monitor 10. In general, the touch screen interface 100 provides an intuitive, gesture-oriented control for the physiological monitor 10. In particular, the touchscreen display 20 presents a user with interface constructs 110 responsive to finger controls 120 so as to change displays and settings, such as monitor operating characteristics, display contents and display formats using a finger touch, a finger touch and move, or a fingertip flick.

[0017] As shown in **FIG. 1**, interface constructs 110 include a scroller 111, a spinner 112, a slider 113, a slider-spinner 114 and a scalable parameter well 115. A scroller 111 is described below with respect to FIGS. 2-3. A spinner 112 is described below with respect to FIGS. 4A-C. A slider 213 is described below with respect to FIGS. 2-3. A slider-spinner 214 is described below with respect to FIGS. 5A-B. A scalable parameter well 216 is described below with respect to FIGS. 7A-D.

[0018] Also shown in **FIG. 1**, finger controls 120 include a touch 121, a touch and move 121 and a flick 121. A touch 121 is finger contact with an active display area. A touch and move 121 is finger contact in conjunction with finger movement in a particular direction. A flick 121 is finger contact in conjunction with a quick finger movement in a particular direction.

[0019] **FIGS. 2-7** illustrate various touchscreen interface constructs 110 (**FIG. 1**) for controlling a physiological monitor 10 (**FIG. 1**), as described above. **FIGS. 2A-D** illustrate a scroller 200 construct configured for a touchscreen display. The scroller 200 is organized as a menu 210 disposed on a virtual, horizontally-rotatable loop. Only a viewable section 201-204 of the menu 210 is visible on the display at any given time. The scroller 200 is responsive to finger controls so as to bring into view any menu section, as described below.

[0020] Also shown in **FIGS. 2A-D**, a scroller 200 embodiment has thumbnails 250 disposed on a second, virtual, horizontally-rotatable loop located in a display well 211. The menu 210 has menu icons 230 and corresponding menu titles 240. The thumbnails 250 have a one-to-one correspondence to the menu icons 230, as indicated by thumbnail icons corresponding to the menu icons or thumbnail initials corresponding to the menu titles 240.

[0021] Further shown in **FIGS. 2A-D**, the scroller 200 advantageously allows for an unrestricted number of menu items. A user can rotate the scroll left or right using *touch and move* 122 (FIG. 1). A user can scroll left or right with velocity using *flick* 123 (FIG. 1). Further, a user can navigate to a menu item using *touch* 121 (FIG. 1) on menu item icon or title. In addition, a user can quick scroll to menu item using *touch* 121 (FIG. 1) on a thumbnail in the display well 211.

[0022] As shown in **FIGS. 2A-D**, when the user applies *touch and move* 207 (FIG. 2A) to the menu icons the user can freely and smoothly slide the menu 201 (FIG. 2A) to the left 202 (FIG. 2B) or the right. On release the menu icons snap and lock 203 (FIG. 2C) to their closest grid location employing an ease-in animation so the transition is smooth and natural and not abrupt. Then, on *touch* 208 (FIG. 2C) the user can navigate to any visible menu option 210. The navigate executes on release.

[0023] Further shown in **FIGS. 2C-D**, when the user wants to jump to a menu item not on the screen they can use a quick scroll. The user applies *touch* 209 (FIG. 2C) on a particular thumbnail indicator (K) 233 and the icon menus scroll into position giving center focus to the menu item (Icon K) 214 FIG. 2D represented by the touched thumbnail indicator 233. As shown in FIG. 2D, once the icon menu scroll animation is complete, the thumbnail indicators rapidly slide to their new orientation.

[0024] When the user applies *flick* (not shown) to the menu icons 210, the menu icons move with velocity along the horizontal vector the gesture implied and the icon menus slide into place. In particular, when the menu icons momentum decreases and they begin to come to a stop, the menu icons will snap to their closest grid location as described above.

[0025] **FIGS. 3A-C** illustrate a physiological monitor main menu 301 (FIG. 3A) and sub-menus 302, 303 (FIGS. 3B-C) implemented with a scroller construct, as described above with respect to FIGS. 2A-D. For example, a user may *touch* "parameter settings" 310 in the main menu scroller 301 and be presented with a parameter menu stroller 302. The user may then *touch* "alarm limits" 320 in the parameter settings stroller 302 and be presented with the alarm limits scroller 303.

[0026] **FIGS. 4A-C** illustrate a spinner having one or more tiers, which open one at a time. Shown is a two-tiered spinner 400. Each spinner tier 410, 420 can



display any specified number. The user applies *touch* to open one tier of the spinner at a time. The spinner elements include a label 430, buttons 440 and corresponding button text. A tier open state 401 (FIG. 4B), 402 (FIG. 4C) has two preceding and two trailing values on a spinner element, and a spinner closed state 403 (FIG. 4B) displaying the selected value. In the spinner open state, the user can use a vertical *touch and move* or *flick* to adjust the value. When open, a spinner tier overlays other user controls on the screen. To close the spinner the user can *touch* the center, highlighted value or another control on the screen.

[0027] FIGS. 5A-B illustrate a slider 500 that allows one touch value settings, such as for parameter limits as one example. FIG. 6 illustrates a slider-spinner 600 embodiment, which is a combination of a slider and spinner, each described separately above. A slider-spinner 600 advantageously allows both a quick and an accurate capability to set a value. In particular, the slider 601 allows a user to quickly get to a specific range and the spinner allows a fine adjustment of that range.

[0028] FIGS. 7A-D illustrate a scalable parameter display 700 and corresponding parameter well 710 advantageously providing a parameter monitor touchscreen with dynamic allocation of the parameter display area 700 so as to maximize screen capability and a caregiver's ability to automatically emphasize and distinguish parameters of greater importance from parameters of lesser importance. In particular, different monitor users care about different parameters. For example, a hemotologist might focus on blood-related parameters, such as SpHb, a noninvasive and continuous reading of total hemoglobin. Accordingly, the user has the ability to remove parameters of little or no interest from a main display area 700 and to place them in the parameter well 710. This is accomplished by a touch and hold gesture over a parameter to select the parameter, followed by a drag and drop gesture to remove the selected parameter from the main display area 700 into the well 710. The parameters remaining in the main display area 700 become bigger in size according to the number of remaining parameters. The removed parameters become smaller in size according to the number of parameters in the well 710. That is, the monitor dynamically adjusts parameter size according the available main display and well display areas. For example, FIG. 7A illustrates eight parameters in the main display 700 and one parameter (SpOC) in the well 710. FIG. 7B illustrates the

relative size of six parameters in the main display 700, with three parameters in the well 710. FIG. 7C illustrates three parameters in the main display 700 dynamically increasing in size and six parameters in the well 710. FIG. 7D illustrates a single, very large SpO2 parameter advantageously solely displayed 700 so as to provide particular emphasis to that parameter and in a manner that can be seen across a room and readily noticed and monitored for change even by caregivers passing by at a distance. Sensors trigger parameters that are displayed so as not to hold space for non-active parameters.

**[0029]** A physiological monitor touchscreen interface has been disclosed in detail in connection with various embodiments. These embodiments are disclosed by way of examples only and are not to limit the scope of the claims herein. One of ordinary skill in art will appreciate many variations and modifications.

WHAT IS CLAIMED IS:

1. A physiological monitor touchscreen interface presents interface constructs on a touchscreen display that are particularly adapted to finger gestures so to change at least one of a physiological monitor operating characteristic and a physiological touchscreen display characteristic, the physiological monitor touchscreen interface comprising:

a first interface construct operable to select a menu item from a touchscreen display; and

a second interface construct operable to define values for the selected menu item.

2. The physiological monitor touchscreen interface according to claim 1 wherein the first interface construct comprises:

a first scroller that presents a rotating set of the menu items in a touchscreen display area; and

a second scroller that presents a rotating set of thumbnails in a display well;

wherein the thumbnails reference the menu items and the thumbnails rotate with the menu items.

3. The physiological monitor touchscreen interface according to claim 2 wherein the first scroller presents a rotating set of second level menu items upon selection of the menu item.

4. The physiological monitor touchscreen interface according to claim 3 wherein the second interface construct is a slider for selecting limits for one of the second level menu items.

5. The physiological monitor touchscreen interface according to claim 4 further comprising a spinner used in conjunction with the slider for making a first gross limit selection with the slider followed by a finer limit selection with the spinner.

6. The physiological monitor touchscreen interface according to claim 5 wherein the touchscreen display further comprises:

a parameter area for displaying parameter values in a full presentation format; and

a parameter well area for displaying parameter values in a abbreviated presentation format; and

the full presentation format being a larger font that the abbreviated presentation format.

7. The physiological monitor touchscreen interface according to claim 6 further comprising a dynamic space allocation for the parameters values presented in the parameter area such that the more parameters in the parameter area and, accordingly, the fewer parameters in the parameter well area, the larger the display font for the parameters in the parameter area.

8. A physiological monitor touchscreen interface method for customizing a physiological monitor comprising:
  - defining a virtually rotating menu scroller;
  - flicking a first icon on the menu scroller so as to spin the rotating menu;and
  - touching a second icon on the menu scroller so as to open a corresponding menu selection.
9. The physiological monitor interface method according to claim 8 further comprising:
  - synchronizing a thumbnail scroller with the menu scroller; and
  - touching a thumbnail within the thumbnail scroller so as to open a menu selection.
10. The physiological monitor interface method according to claim 9 further comprising touching and moving a slider so as to set a parameter value.
11. The physiological monitor interface method according to claim 10 further comprising opening a spinner so as to refine the parameter value.
12. The physiological monitor interface method according to claim 11 wherein opening the spinner comprises opening a first tier of the spinner to define a first parameter limit.
13. The physiological monitor interface method according to claim 12 wherein opening the spinner comprises opening a second tier of the spinner to define a second parameter limit.
14. The physiological monitor interface method according to claim 13 further comprising scaling a plurality of parameters within a parameter display area by moving at least one of the parameters between the parameter display area and a parameter well area.

15. A physiological monitor touchscreen interface comprising a first scroller means for virtually rotating a plurality of menu items under finger control across a parameter display area of a touchscreen display.

16. The physiological monitor interface method according to claim 15 further comprising:

a second scroller means for virtually rotating a plurality of thumbnail means within a parameter well area of the touchscreen display;

the second scroller means rotating in response to the first scroller means.

17. The physiological monitor interface method according to claim 16 further comprising a slider means for grossly defining values for selected one of the menu items.

18. The physiological monitor interface method according to claim 17 further comprising a spinner means for finely defining values for the selected one of the menu items, where the spinner means is used in conjunction with the slider means.

19. The physiological monitor interface method according to claim 18 further comprising a scalable means for increasing the size of displayed parameters according to the number of displayed parameters.

20. The physiological monitor interface method according to claim 19 further comprising a parameter well means for removing parameters from a parameter display area so as to increase the size of the displayed parameters.

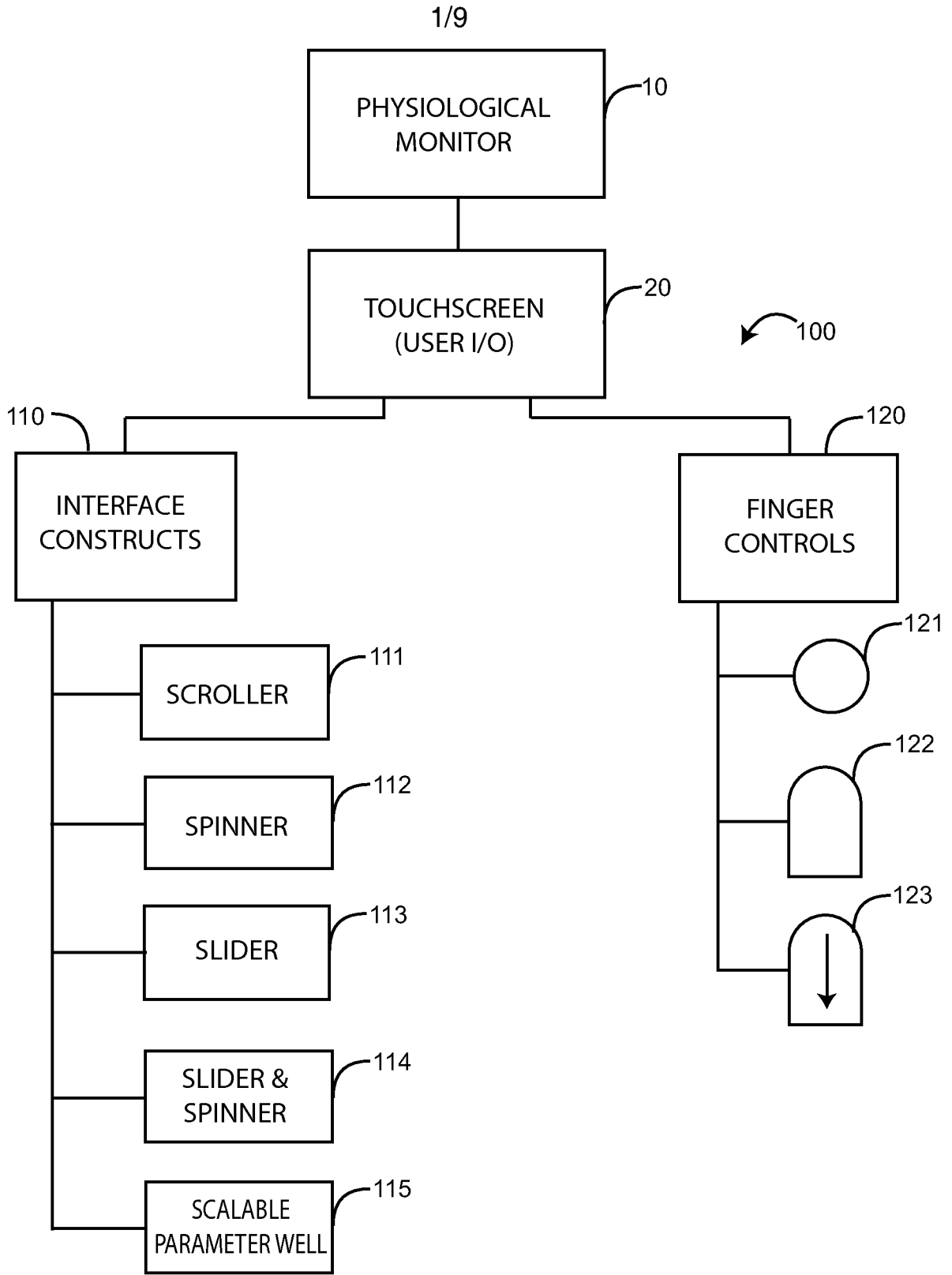

FIG. 1

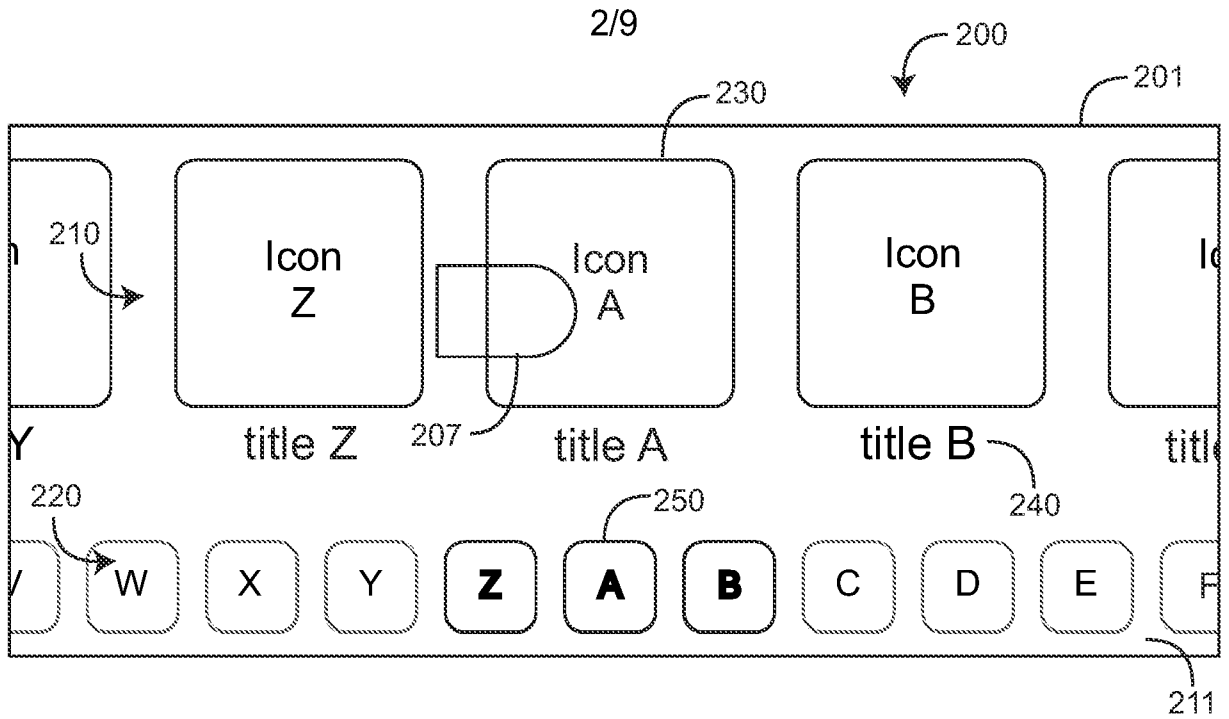

FIG. 2A

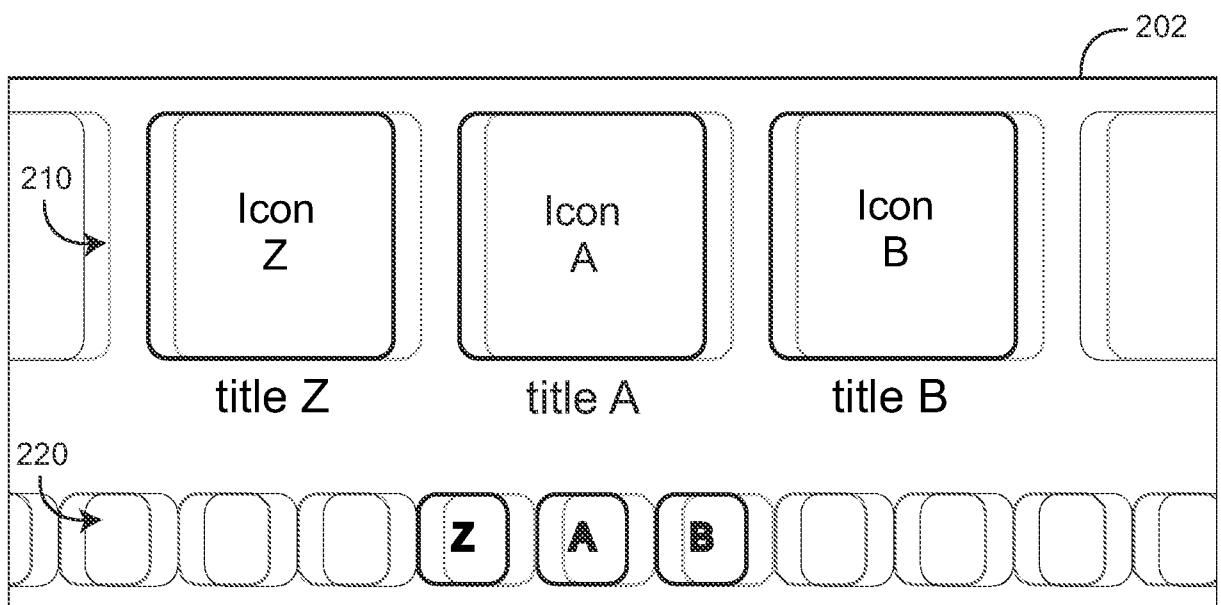

FIG. 2B



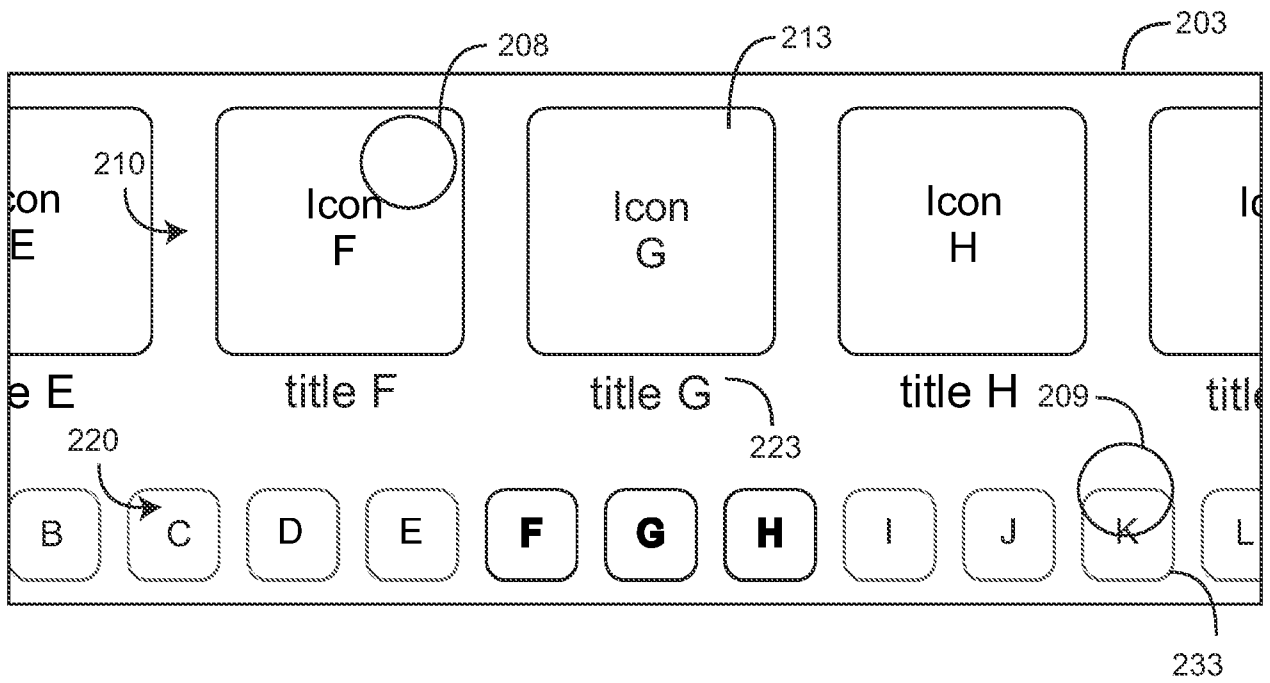

FIG. 2C

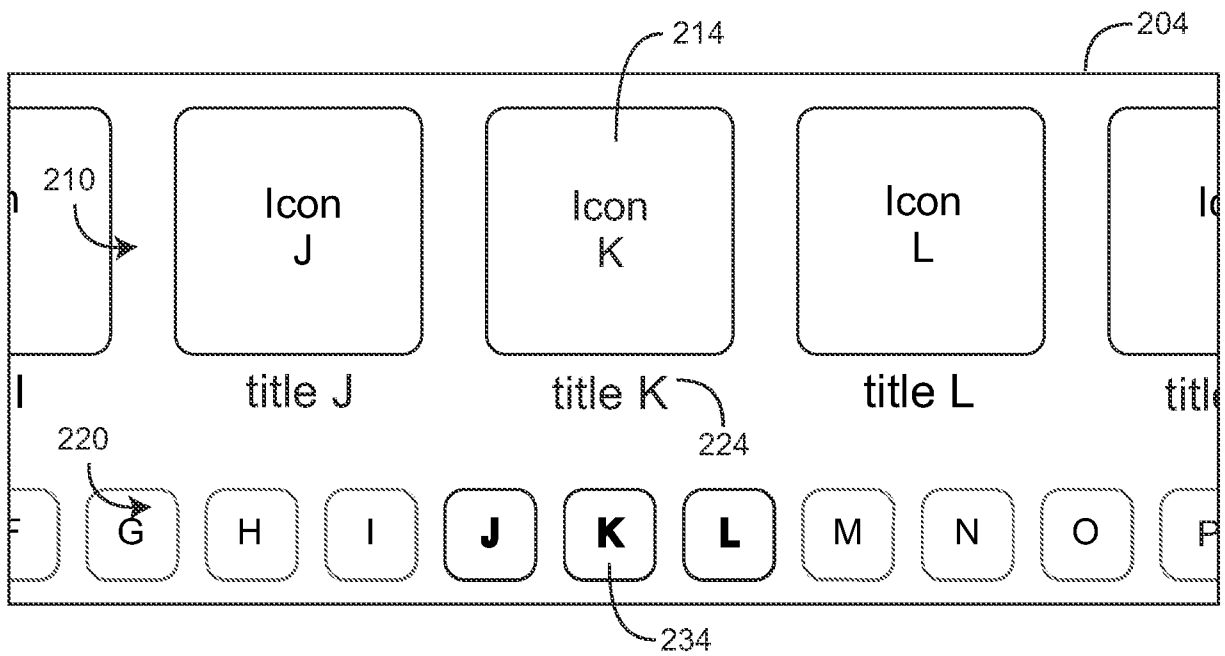

FIG. 2D

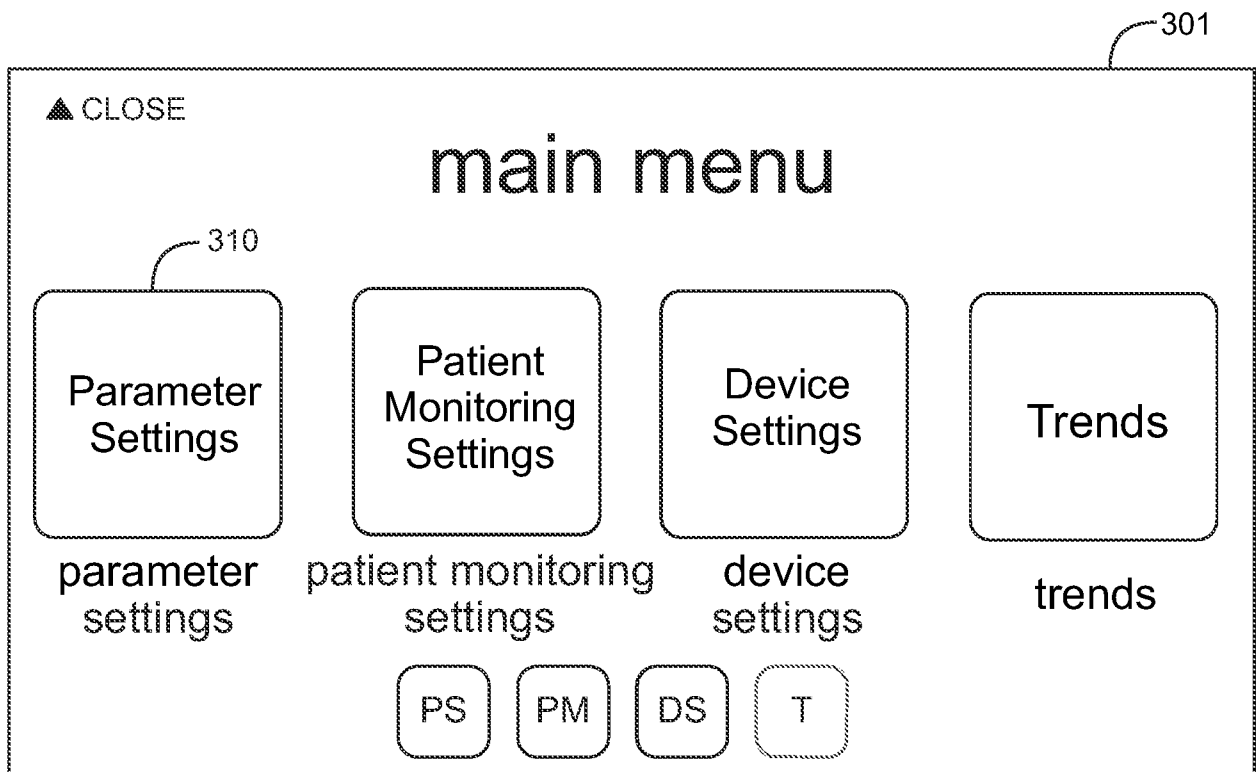

FIG. 3A

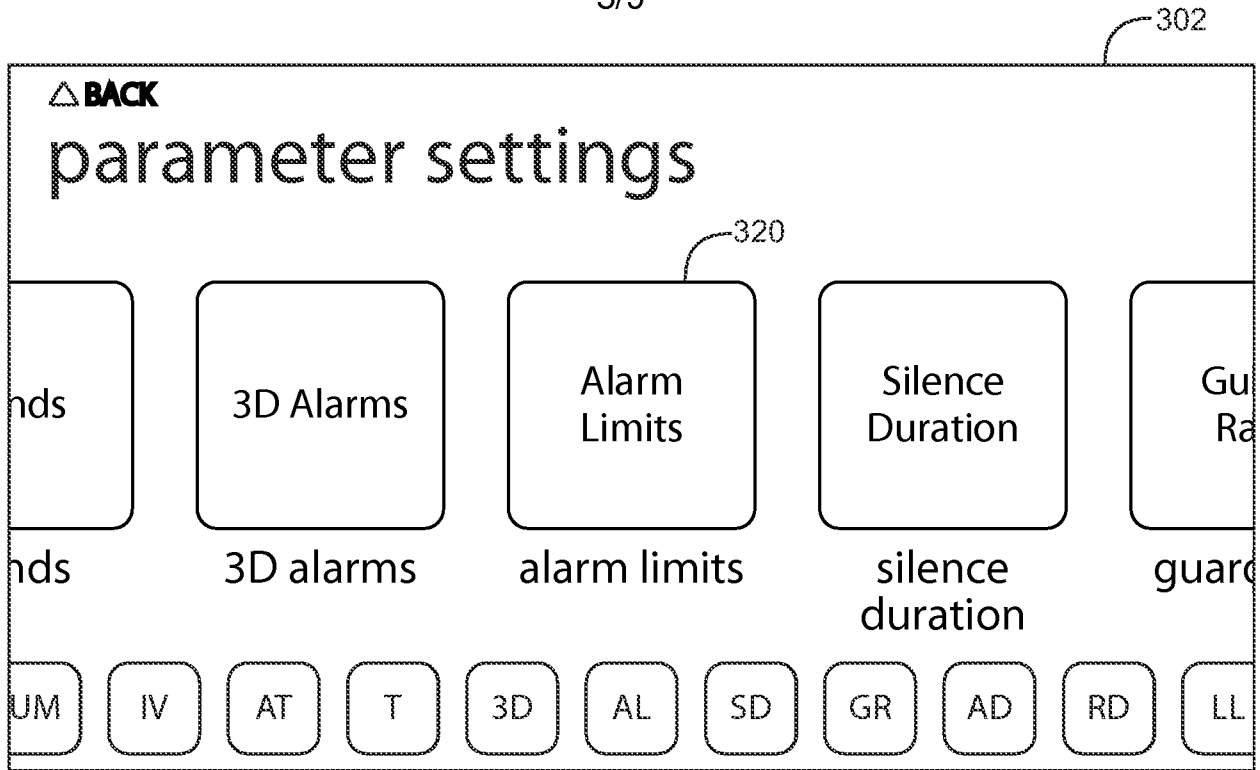

FIG. 3B

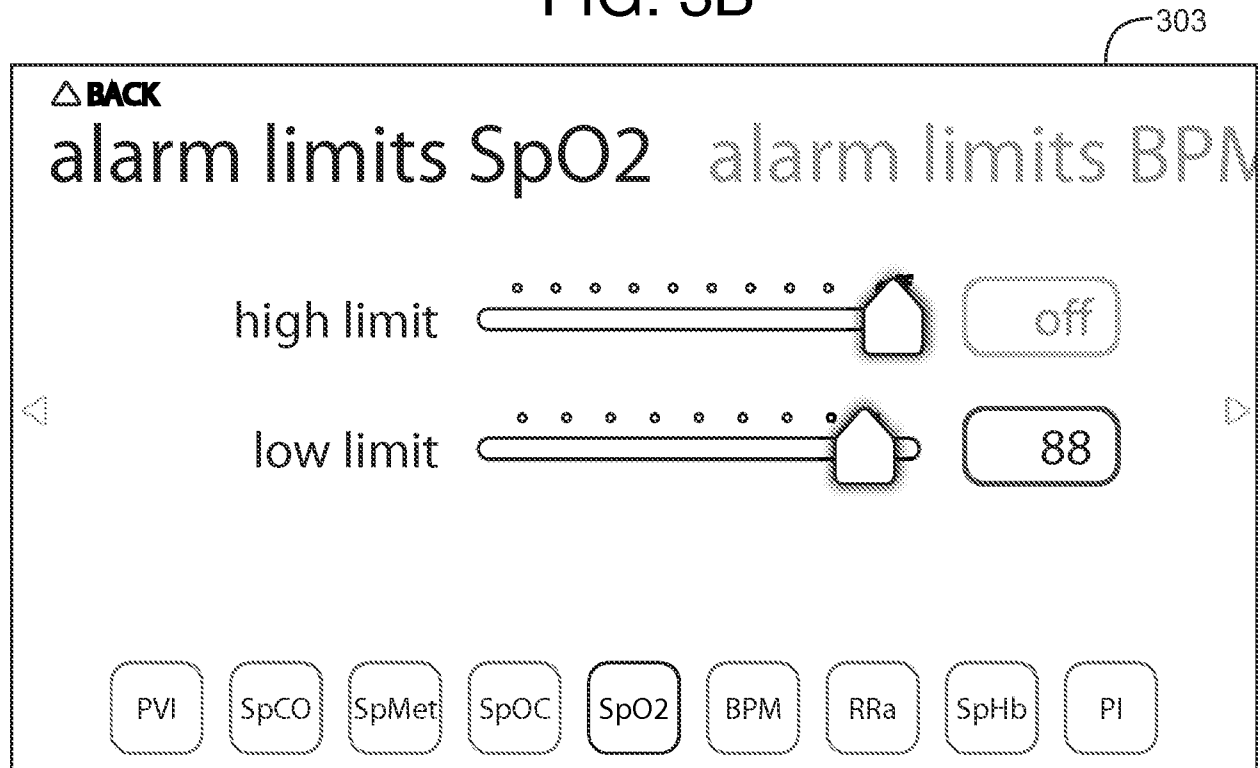

FIG. 3C

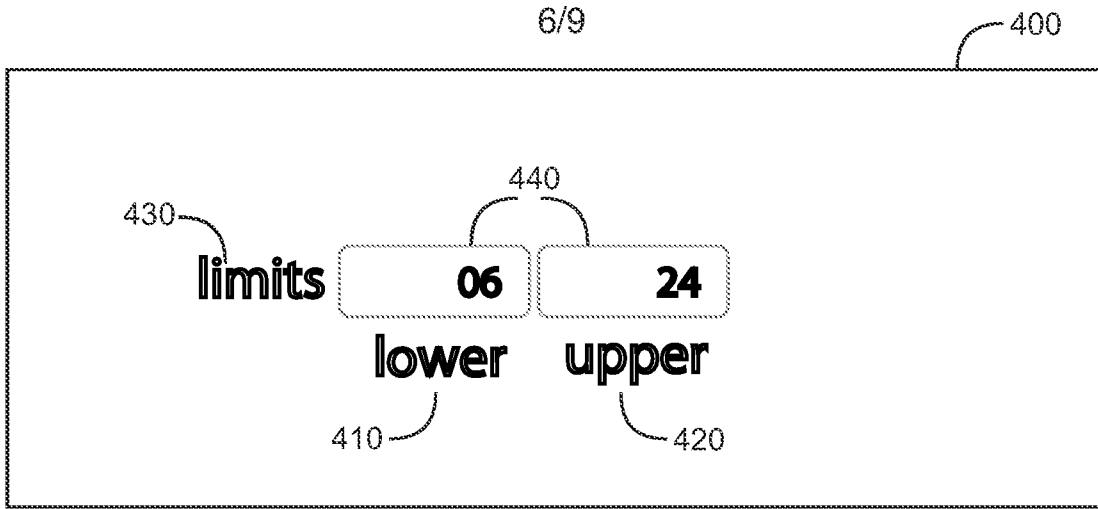

FIG. 4A

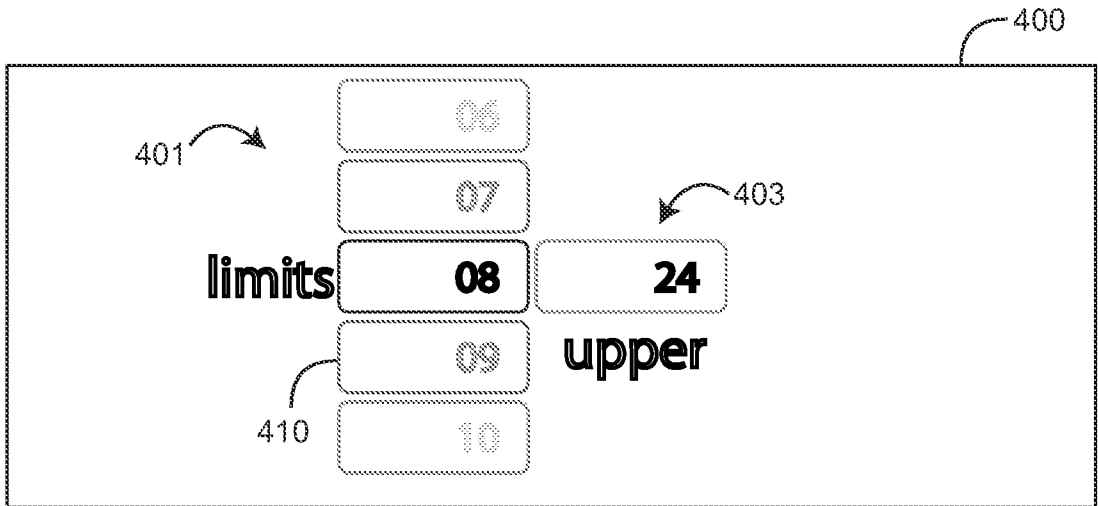

FIG. 4B

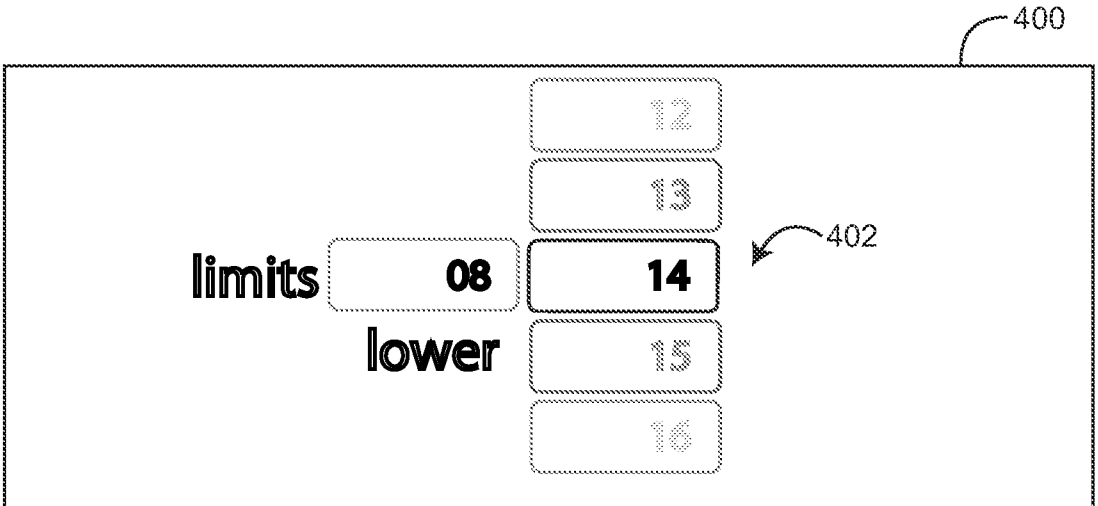

FIG. 4C

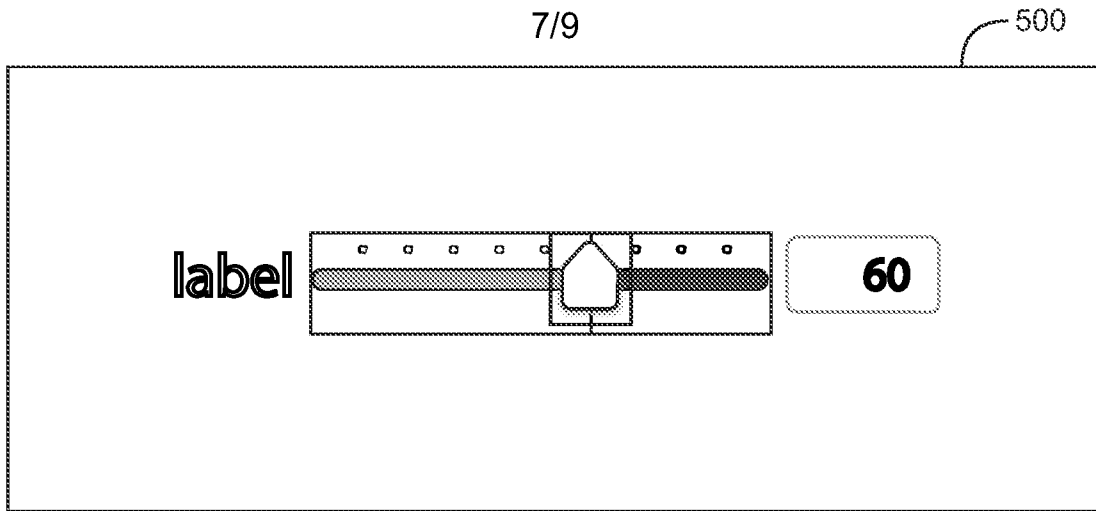

FIG. 5A

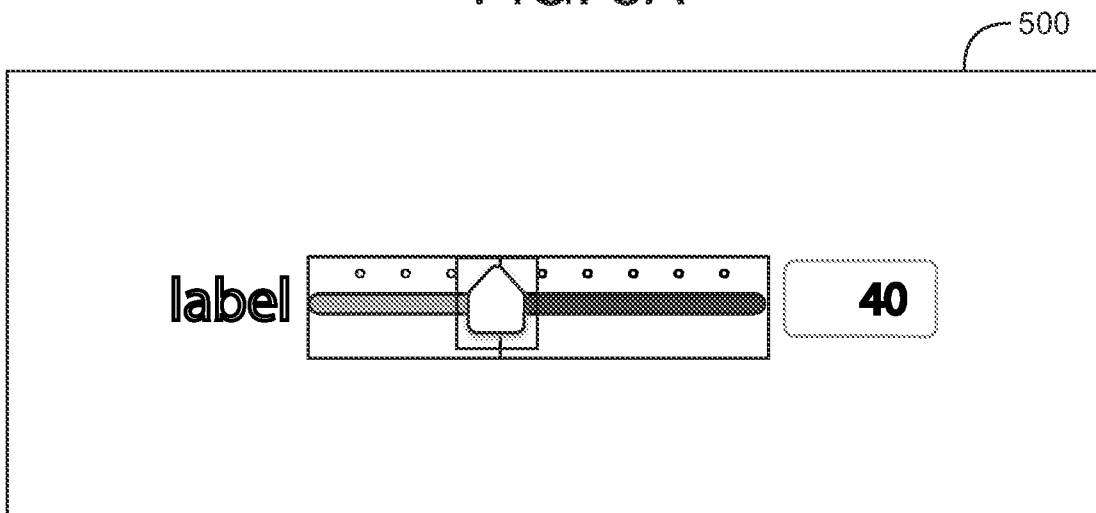

FIG. 5B

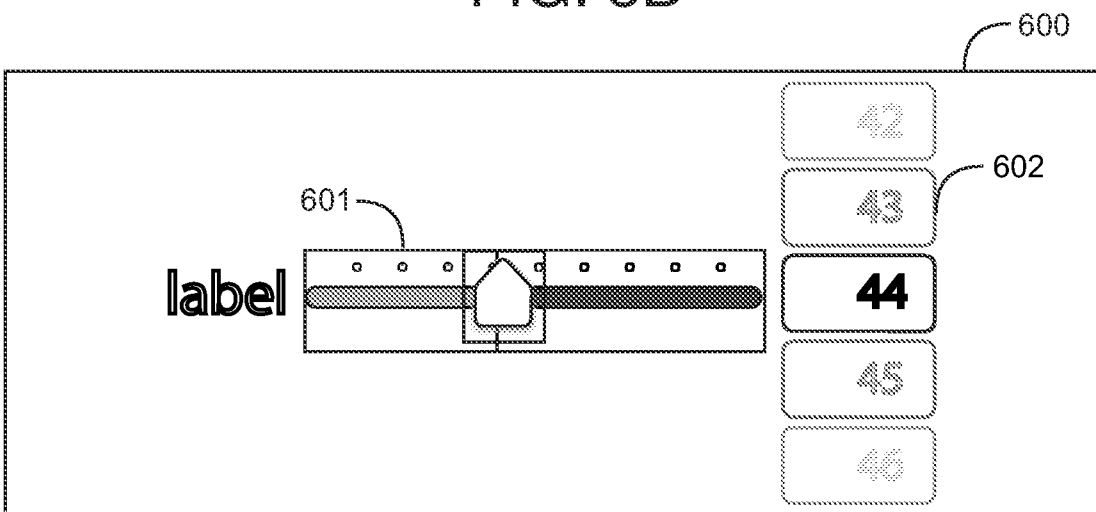

FIG. 6

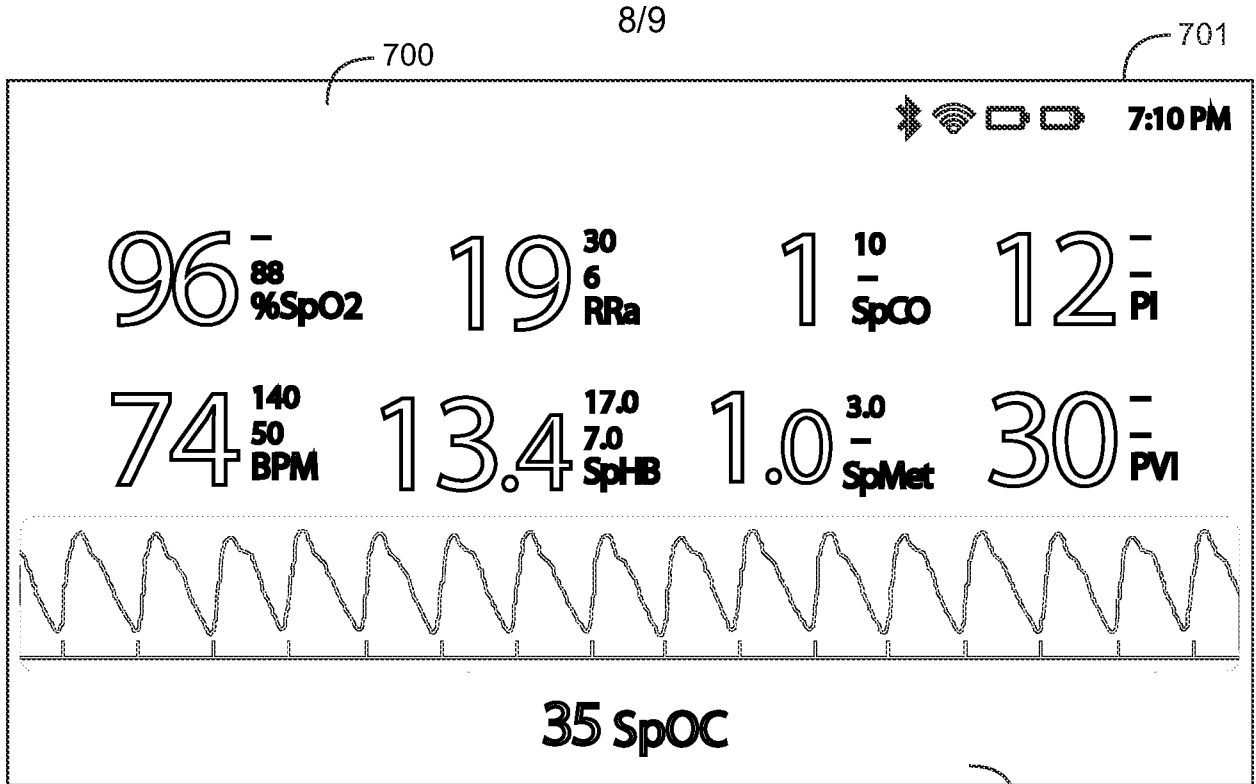

FIG. 7A

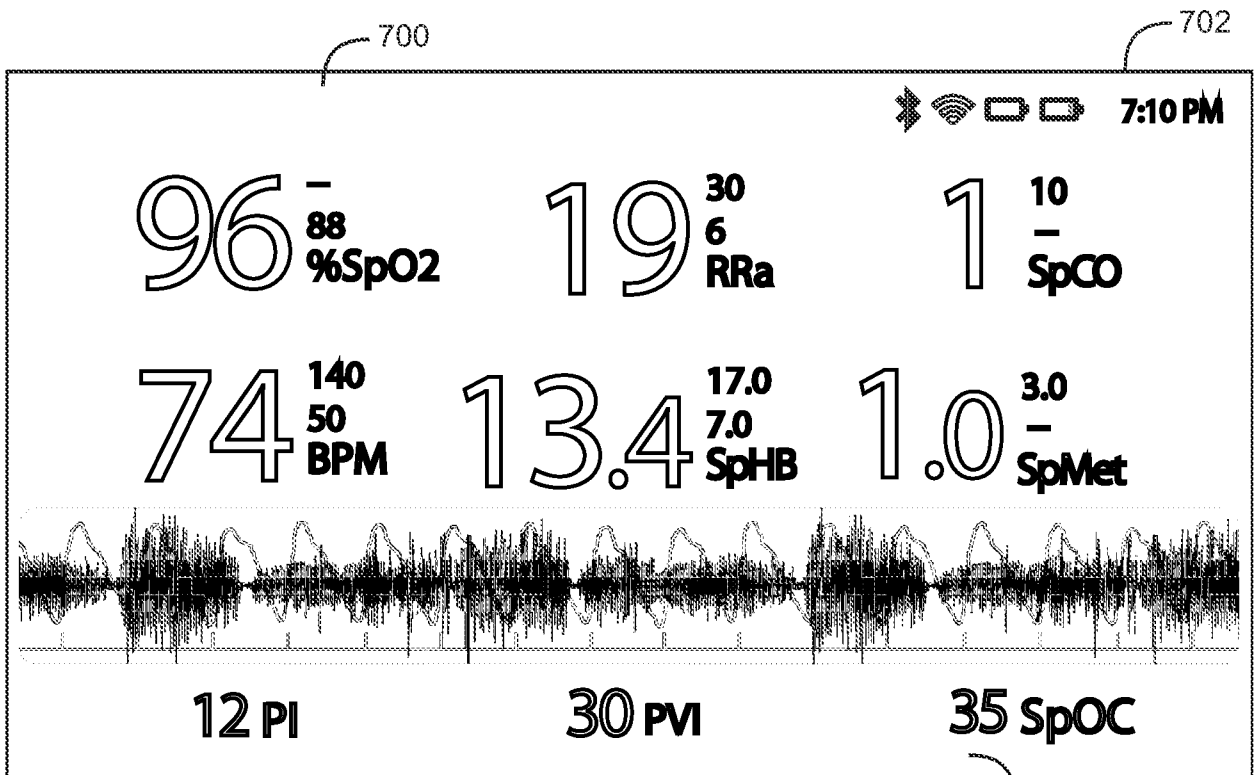

FIG. 7B

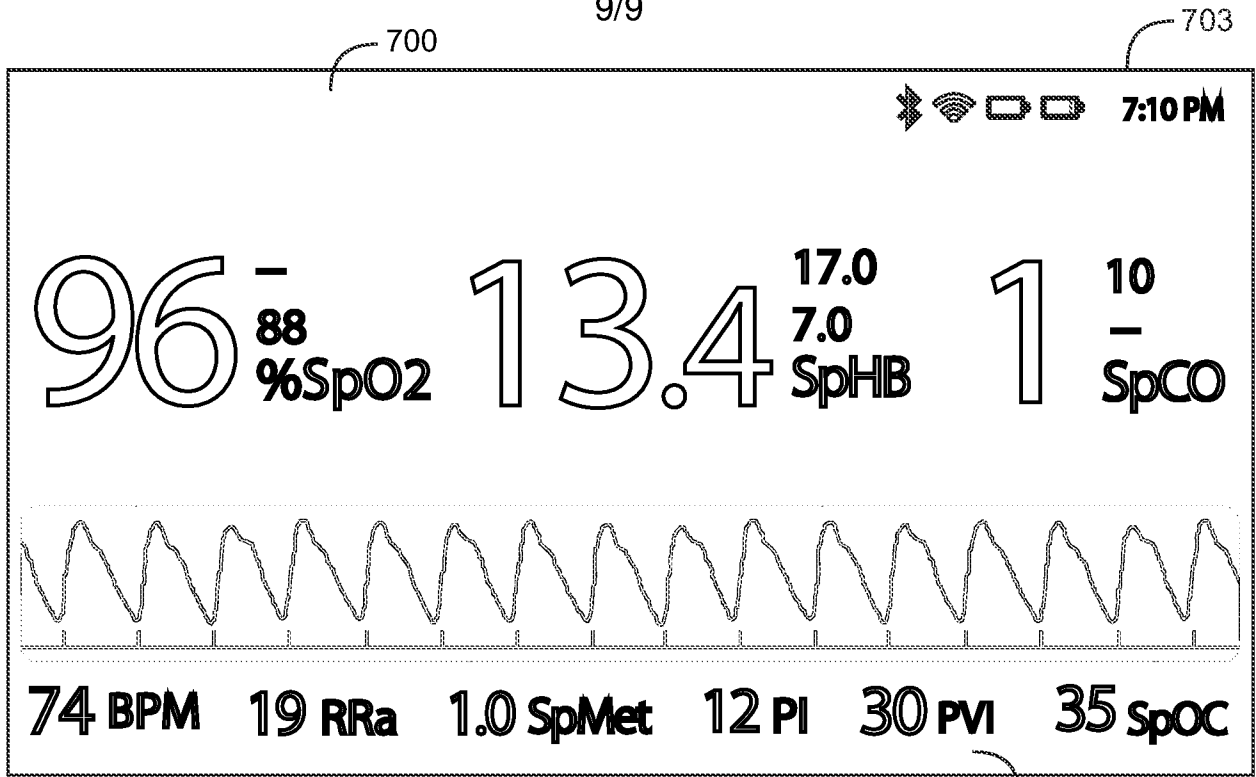

FIG. 7C

710

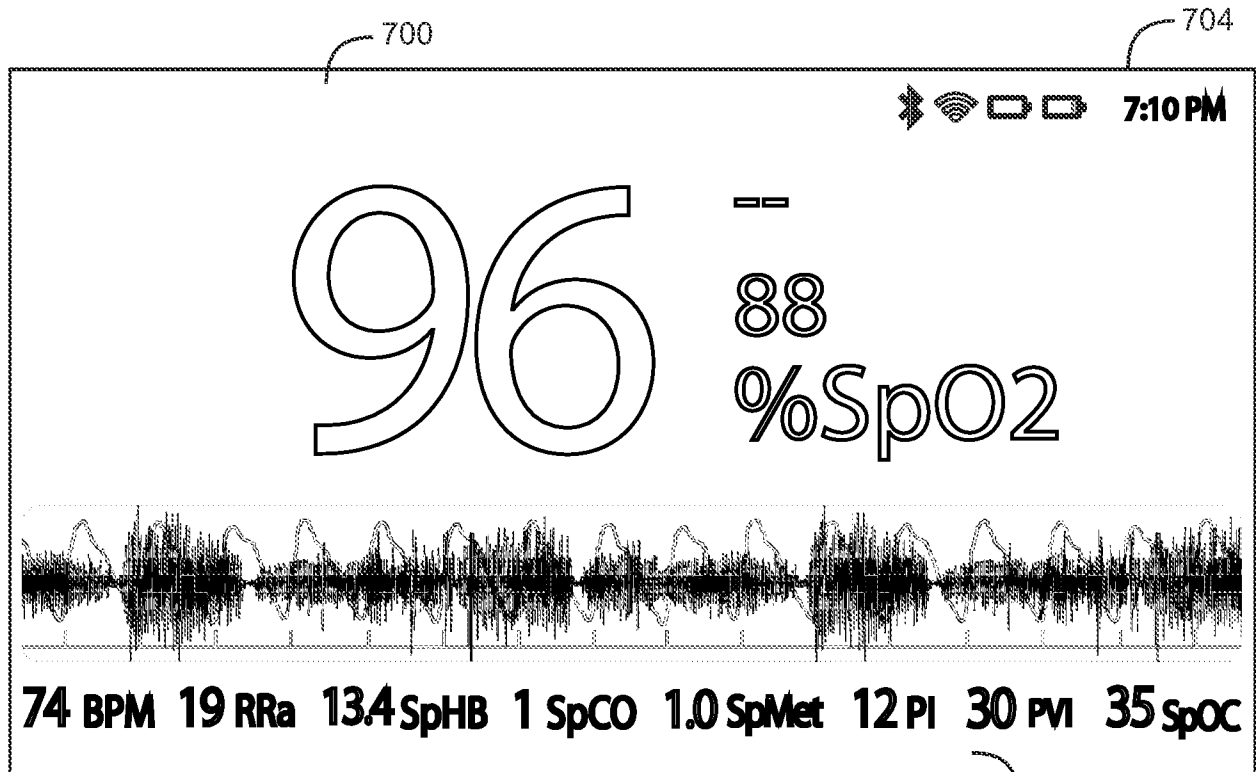

FIG. 7D

710

**INTERNATIONAL SEARCH REPORT**

International application No  
PCT/US2013/033762

A. CLASSIFICATION OF SUBJECT MATTER  
INV. G06F3/0488 G06F3/0482 G06F3/0485 G06F3/0484 G06F3/0486  
ADD.  
According to International Patent Classification (IPC) or to both national classification and IPC

B. FIELDS SEARCHED  
Minimum documentation searched (classification system followed by classification symbols)  
G06F  
Documentation searched other than minimum documentation to the extent that such documents are included in the fields searched

Electronic data base consulted during the international search (name of data base and, where practicable, search terms used)  
EPO-Internal, WPI Data

C. DOCUMENTS CONSIDERED TO BE RELEVANT		
Category*	Citation of document, with indication, where appropriate, of the relevant passages	Relevant to claim No.
X	US 2012/026119 A1 (JUDY JOHN [US] ET AL) 2 February 2012 (2012-02-02) paragraphs [0036] - [0037]; figure 2 paragraphs [0074] - [0083]; figures 8-9 -----	1
X	US 2011/317192 A1 (FUKUOKA KAORU [JP] ET AL) 29 December 2011 (2011-12-29) paragraphs [0044] - [0094]; figures 3-8 -----	1-20
X	EP 2 112 594 A2 (NINTENDO CO LTD [JP]) 28 October 2009 (2009-10-28) paragraphs [0061] - [0075]; figures 1-4 -----	1-20
X	US 2009/019401 A1 (PARK WAN-JE [KR] ET AL) 15 January 2009 (2009-01-15) paragraphs [0047] - [0120]; figures 1-11 -----	8
A	----- -/--	3

Further documents are listed in the continuation of Box C.  See patent family annex.

\* Special categories of cited documents :

"A" document defining the general state of the art which is not considered to be of particular relevance	"T" later document published after the international filing date or priority date and not in conflict with the application but cited to understand the principle or theory underlying the invention
"E" earlier application or patent but published on or after the international filing date	"X" document of particular relevance; the claimed invention cannot be considered novel or cannot be considered to involve an inventive step when the document is taken alone
"L" document which may throw doubts on priority claim(s) or which is cited to establish the publication date of another citation or other special reason (as specified)	"Y" document of particular relevance; the claimed invention cannot be considered to involve an inventive step when the document is combined with one or more other such documents, such combination being obvious to a person skilled in the art
"O" document referring to an oral disclosure, use, exhibition or other means	"&" document member of the same patent family
"P" document published prior to the international filing date but later than the priority date claimed	

Date of the actual completion of the international search <b>6 June 2013</b>	Date of mailing of the international search report <b>13/06/2013</b>
---	---

Name and mailing address of the ISA/ European Patent Office, P.B. 5818 Patentlaan 2 NL - 2280 HV Rijswijk Tel. (+31-70) 340-2040, Fax: (+31-70) 340-3016	Authorized officer <b>Legrand, J</b>
--	---



## INTERNATIONAL SEARCH REPORT

International application No

PCT/US2013/033762

C(Continuation). DOCUMENTS CONSIDERED TO BE RELEVANT		
Category*	Citation of document, with indication, where appropriate, of the relevant passages	Relevant to claim No.
A	<p>Anonymous: "Configuring the Microphones Using AP-Ware",  17 February 2009 (2009-02-17),  XP055065304,  Retrieved from the Internet:  URL:<a href="http://web.archive.org/web/20090217190928/http://www.accessgrid.org/agdp/howto/config-gentner-ap400/1.5.1/html/x430.html">http://web.archive.org/web/20090217190928/http://www.accessgrid.org/agdp/howto/config-gentner-ap400/1.5.1/html/x430.html</a>  [retrieved on 2013-06-05]  page 3</p>	4,5, 10-13, 17,18
A	<p>-----  US 7 374 535 B2 (SCHOENBERG IDO [IL] ET AL) 20 May 2008 (2008-05-20)  column 6, line 46 - column 7, line 67;  figures 2A, 2B</p>	6,7,14, 19,20
A	<p>-----  EP 1 965 324 A1 (CORPORACIO SANITARIA PARC TAUL [ES]) 3 September 2008 (2008-09-03)  paragraph [0073]; figures 4-5  -----</p>	6,7,14, 19,20

# INTERNATIONAL SEARCH REPORT

Information on patent family members

International application No PCT/US2013/033762
---

Patent document cited in search report	Publication date	Patent family member(s)	Publication date
US 2012026119	A1	02-02-2012	NONE
-----			
US 2011317192	A1	29-12-2011	JP 5067448 B2 07-11-2012
			JP 2012006263 A 12-01-2012
			US 2011317192 A1 29-12-2011
-----			
EP 2112594	A2	28-10-2009	EP 2112594 A2 28-10-2009
			JP 4171770 B1 29-10-2008
			JP 2009265929 A 12-11-2009
			US 2009271723 A1 29-10-2009
-----			
US 2009019401	A1	15-01-2009	KR 20090005680 A 14-01-2009
			US 2009019401 A1 15-01-2009
-----			
US 7374535	B2	20-05-2008	AU 5405798 A 31-07-1998
			US 6322502 B1 27-11-2001
			US 2002177758 A1 28-11-2002
			US 2002177759 A1 28-11-2002
			US 2003036687 A1 20-02-2003
			US 2005125256 A1 09-06-2005
			US 2008208618 A1 28-08-2008
			US 2011004489 A1 06-01-2011
			WO 9829790 A2 09-07-1998
-----			
EP 1965324	A1	03-09-2008	EP 1965324 A1 03-09-2008
			EP 2115647 A2 11-11-2009
			JP 2010519975 A 10-06-2010
			KR 20090116810 A 11-11-2009
			US 2010106825 A1 29-04-2010
			WO 2008104602 A2 04-09-2008
-----			