



Europäisches Patentamt
European Patent Office
Office européen des brevets



(11) **EP 1 206 608 B1**

(12) **EUROPEAN PATENT SPECIFICATION**

(45) Date of publication and mention
of the grant of the patent:

28.12.2005 Bulletin 2005/52

(21) Application number: **00951268.2**

(22) Date of filing: **03.08.2000**

(51) Int Cl.7: **E04D 1/00**

(86) International application number:
PCT/DK2000/000434

(87) International publication number:
WO 2001/009457 (08.02.2001 Gazette 2001/06)

(54) **METHOD AND BINDER FOR LAYING AND ANCHORING PANTILES ON ROOF CONSTRUCTIONS COMPRISING SUB ROOF**

VERFAHREN UND KLAMMER ZUM LEGEN UND BEFESTIGEN VON DACHPFANNEN AUF DÄCHERN MIT EINEM UNTERDACH

PROCEDE ET FRETTE DE POSE ET D'ANCRAGE DE TUILES PANNE SUR DES CONSTRUCTIONS DE TOIT COMPRENANT UN SOUS-TOIT

(84) Designated Contracting States:
**AT BE CH CY DE DK ES FI FR GB GR IE IT LI LU
MC NL PT SE**
Designated Extension States:
LT LV

(30) Priority: **03.08.1999 DK 108599**

(43) Date of publication of application:
22.05.2002 Bulletin 2002/21

(73) Proprietor: **Jensen, Victor Sonne
8832 Skals (DK)**

(72) Inventor: **Jensen, Victor Sonne
8832 Skals (DK)**

(74) Representative: **Nielsen, Leif et al
Patrade A/S
Fredens Torv 3A
8000 Aarhus C (DK)**

(56) References cited:
**DE-A- 3 333 937 DE-C- 148 026
DK-C- 25 298 FR-E- 33 862
SE-C- 53 556**

EP 1 206 608 B1

Note: Within nine months from the publication of the mention of the grant of the European patent, any person may give notice to the European Patent Office of opposition to the European patent granted. Notice of opposition shall be filed in a written reasoned statement. It shall not be deemed to have been filed until the opposition fee has been paid. (Art. 99(1) European Patent Convention).

Description

[0001] The present invention concerns a method for the laying and anchoring of pantiles on rafters on roof constructions with sub roof. The invention also concerns a tile binder of stiff material for use in the execution of the method, of the kind which is used for the laying and anchoring of pantiles on roof constructions with sub roof, and comprising an insertion part for insertion in the binding boss on the underside of the tile, and in extension herewith a part standing in connection with a gripping end part.

[0002] Roof-tile binders are used in connection with the laying of roofs consisting of tiles or other materials (in the following mutually called tiles), with the view to achieving a certain anchoring of the tiles to the underlying rafters in the event of outwardly-directed wind forces as a result of the influence by wind on the roof construction.

[0003] The underside of the tile, cf. fig. 1, comprises a binding boss 5 and a laying boss 7 at the front edge. The binding boss, which consists of a projection on the underside of the tile, is provided with a through-going hole 3, cf. fig. 3, disposed in the longitudinal direction of the tile for the accommodation of the straight end part 4 of a wire-formed tile binder, the other end of which is staggered in relation to said end part, and which in the laying of the tile is introduced in behind the rafter closest to the foot (lower part) of the tile, or that rafter (10) on which the upper end of the underlying tile 22 is supported, where the staggered end of the binder is in contact with that side of said rafter which faces towards the sub roof (not shown). The laying boss 7 consists of a projection on the underside of the tile at the top 24 (upper end) of the tile. In the correctly laid out position of the tile, the under edge 9 of the laying boss is in abutment with the upper edge 11 of an underlying rafter 30, so that the tile is held and secured by the rafter (for the sake of clarity and understanding, in figs. 1 and 3 a clearance is shown in between the under edge of the laying boss and the upper edge 11 of the rafter 30).

[0004] The known tile binders typically consist of a stiff piece of round wire of steel with a strength of 16-1800 N/mm², and they are shaped as shown in fig. 1. The known tile binder 2 comprises a straight free insertion part 4 for insertion from the lower end of the tile into the hole in the boss 5 of a tile 6, and a gripping end part 8 for anchoring in abutment against a rafter 10, and a slightly curved intermediate length 12 in between said parts, beginning with an approximately right-angled bend 14 followed by two consecutive 45° bends 16, 18, and ending with a bending-over 20 of the wire in towards itself to form the gripping end part 8, whereby the tile binder 2 is able to be placed extending around the underlying tile 22 and the rafter 10. It must be noted that in the mounted state, the obtuse extending end of the bend is not intended to engage with the side of the rafter 10, but serves merely to stabilise the tile binder in the

event of possible influence by outwardly-directed, transverse forces on the tile 6, and to prevent damage to the sub roof when the tile binder is mounted. The tile binder is secured in its position partly by friction which arises by the abutment pressure of the staggered end part against the rafter 10, and partly due to the fact that the laying boss 7 of the underlying tile prevents the straight insertion part 4 from sliding out of the hole 3 in the binding boss 5, cf. fig. 1.

[0005] The known tile binders, however, have certain disadvantages, e.g. they are very sensitive to incorrect rafter dimensions, which means that the anchoring becomes poor if the rafters are too narrow, and rafters which are too large in dimensions can cause wear damage to arise on the sub roof, and further that the straight free insertion end 4 placed in the boss 5 can give rise to an undesired, outwardly directed force on the upper end 24 of the tile 6 (indicated by the arrow 26 in fig. 1), for the reason that the gripping end part 8 is placed at a greater distance from the underside 28 of the tile. This outwardly-directed force arises in that the insertion part placed in the tile's boss is turned, whereby the outer end of the insertion part exercises an outwardly-directed pressure on the boss, and herewith on the tile, which results in a considerable reduction in the abutments pressure of the upper end of the tile on the underlying rafter. All in all, the latter disadvantage can give rise to an inexpedient effect of the tile binders when the rafters and binders do not correspond with each other. The known tile binders are thus delivered in different dimensions, corresponding to a rafter of a given size, which thus means that a craftsman should/must hold a stock of tile binders of different dimensions.

[0006] From DK 25298 there is known a tile binder for use for under-pointed roof constructions, where there is access to the undersides of the tiles after they have been laid. The tile binder comprises an upper bent-over end for insertion in the hole in the tile's binding boss from above, and a lower end which is of rectangular U-shape and intended to grip around the whole of the underlying rafter with the free end in between the rafter and the underside of the front end of the underlying tile. The tile binder also comprises an intermediate length with a spirally-wound flexible part which makes it possible to stretch the binder during insertion of the upper bent-over end in the tile's binding boss. The tile binder is intended for mounting after the tiles have been laid. After the tiles have been laid, an under-pointing (sealing) of the spaces in between the tiles is carried out with mortar, after which the binders are mounted in that the rectangular U-shaped lower end is led around the rafter, and the bent-over end of the binder is subsequently inserted in the hole in the binding boss, which is possible due to the good possibilities of access to the underside of the tiles.

[0007] The inventor has acknowledged that the anchoring of the tile in accordance with the known technique (disclosed in DK 25298), which has previously been used in connection with under-pointed tiles, is

even particularly expedient, in that the binder exercises a resulting downwards-directed force on the tiles, so that these hereby lie in a firmer manner against the underlying roof construction. The configuration of this known binder, whereby this is secured around the whole of the underlying rafter, results however - due to inadequate space conditions when laying tiles on roof constructions with sub roof, and the lack of possibilities for access to the under side of the tiles for the subsequent mounting of the insertion end of the known tile binder - that this binder can not be used in the laying of tiles on roof constructions with sub roof.

[0008] The object of the invention is thus to provide a method for the laying and anchoring of tiles on roof constructions of the kind disclosed (with sub roof), which ensures an effective and more durable securing of the tiles than with the known method which is used for roof constructions with sub roof, and also a binder for use in the execution of the method.

[0009] This object is achieved by the introduction of the insertion part of a tile binder with a substantially inverted U-shaped insertion part, an intermediate length with a part which provides flexibility, and a gripping end part with a U or V-shaped bend, into the through-going hole in the tile's binding boss or similar insertion opening from the upper end of the binding boss, followed by the placing of the tile on the upper side of the underlying tile, after which the tile is tilted down so that the tile's laying boss is placed on top of the rafter at the top of the tile, whereby the free end of the gripping end part is turned in behind the underside of the rafter at the foot (lower end) of the tile, upon which the tile is pushed upwards, whereby the free end of the gripping end part is brought into abutment with the underside of the rafter at the foot of the tile, and by continued displacement of the tile, stretching (tensioning) of the flexible part of the tile binder, with the laying boss sliding on the outer side of the rafter at the top of the tile, until the front end of the tile falls down on the outer side of the rafter and rests on this with the back of the laying boss in abutment with the upper side of the rafter, whereby the tile is secured.

[0010] There is hereby achieved a considerably improved securing of the tile in comparison with the known method, in that the tile is secured in its correct position by a downwards-directed force brought about by the stretching of the flexible part of the tile binder as a consequence of the anchoring of the gripping end part in the underside of the underlying rafter, which results in both the front edge and the rear edge of the tile being drawn respectively against the foremost rafter and the upper edge of the preceding/underlying tile.

[0011] A tile binder for use in the execution of the method according to the invention comprises a body (a length) of stiff but outwardly-flexible material comprising a substantially reversed U-shaped insertion part for insertion from above in a tile's binding boss or similar insertion opening, said insertion part, via an intermediate length comprising a part which provides elasticity in both

the tile's longitudinal and transverse directions, standing in connection with an anchoring part, characterised in that the anchoring part comprises a substantially straight length having a free end which is concluded with a U- or V-shaped bend for engagement in the underside of the rafter nearest to the foot (lower end) of the tile extending in substantially the same plane as the reversed U-shaped insertion part.

[0012] Out of regard for the achieving of an expedient anchoring of the free end of the bent-over part, it can be mentioned that the directional deviation of the bend in relation to the straight extent of the anchoring part forms an angle within the interval of 90° - 225°, typically between 110° - 200°, and preferably within the interval 120° - 190°.

[0013] By use of the tile binder according to the invention in combination with the method according to the invention, there is hereby achieved a particularly effective anchoring of tiles laid out on roof constructions with sub roof, in that in the correctly laid position on the rafters, by stretching of the elasticity-providing part, the tiles are drawn respectively in against the underlying tile and against the outer side of the rafters which support the front end of the tile. With the tile binder according to the invention, there is thus achieved the same effective anchoring of tiles laid out on roof constructions with sub roof, than has hitherto been possible only when using the previously-mentioned tile binders for use with roof constructions with under-pointed tiles, where subsequent mounting of tile binders is possible as a result of unhindered access to the underside of the roof after the laying of the tiles.

[0014] Laboratory tests have also shown that roof constructions with sub roof provided with tiles anchored with tile binders according to the present invention have been considerably more resistant to wind effects than roofs where the tiles are anchored with the commonly-known tile binders for anchoring of tiles laid on roof constructions with sub roof.

[0015] The configuration of the insertion part as the free end of a U-shaped insertion part makes it possible for the insertion part to be inserted from the upper end of the binding boss (unlike the known tile binders which are inserted in the through-going hole in the boss from below), and in combination with the gripping end part which is brought into abutment with the rafter at the foot of the tile, as already mentioned this results in a considerable improvement of the anchoring of the tile to the underlying roof construction. The reason for this is that when the tile binder is mounted, with the altered point of engagement in the boss, an inclined, downwards-directed resulting force on the tile is achieved in relation to the surface of the tile, regardless of deviations in rafter dimensions as well as in the breadth and the height of the rafters and tiles used in the roof construction, in that compensation is made for these deviations by the elasticity-providing part of the binder. With rafters which are too large, it is thus achieved, unlike with the known tile

binder cf. the above, that the downwards-directed tractive force on the tile is increased with subsequent increase in the stability of the roof. With rafters which are too small, it is achieved merely that the force is reduced, though not more than the said inclined downwards-directed force can be maintained. Consequently, when use is made of the tile binder according to the invention, no outwardly-directed force which could give rise to the roofing tiles becoming unstable is applied to the upper end of the tile under any positioning/building-in/mounting conditions whatsoever. Moreover, the tile binder according to the invention has the further advantage that it can be used together with rafters of different dimensions. Practical tests with the tile binder according to the invention have thus shown that this can be used together with rafters of three different dimensions (30/50, 50/50 and 40/60), which is not possible with the known tile binders where a specific type of binder must be used with rafters of specific dimensions.

[0016] With the view to achieving an expedient distribution of pressure in between the obtuse end of the bend and the rafter, the obtuse end can be flattened so that there is hereby formed a pressure surface with an area which is greater than the cross-sectional area of the obtuse end.

[0017] With the view to providing the tile binder with additional flexibility, its middle section in between the insertion part and the gripping end part can extend in a substantially curved manner.

[0018] Without waiving any other configurations, an advantageous configuration of the curved extent of the middle part can be disclosed as being a bend in the plane of the U-shaped insertion part oriented towards the insertion part, standing in connection with the U-shaped insertion part, followed by an oppositely-directed (outwards-directed) bending of the middle section and thereafter a substantially straight piece continuing over to the elasticity-providing part which is concluded with the gripping end part.

[0019] The elasticity-providing part in the middle section can be configured in different ways, but without waiving other configurations, a preferred embodiment hereof consists of at least one zig-zag bending (W-shaped bending) of the middle section. The possibility is hereby provided for an elastic increase in the length of the middle section when placing the gripping end part of the tile binder on the underside of the nearest rafter, in that a pull on the gripping end part will result in a stretching at the angle bends in the zig-zag-bent area.

[0020] The angles in the tips of the zig-zag bends when the tile binder is not mounted lie within the range of 60-120°, typically within 80-110° and typically between 90-100°.

[0021] The length of the tile binder can also with advantage be adapted so that the angles of the angle bends in the elasticity-providing part when the tile binder is mounted are greater than 90°. It is hereby achieved that the tile binder according to the invention exercises

an adequate downwards-directed force on the tiles, whereby the necessary anchoring of the roof is ensured.

[0022] An adjustment of the flexibility and tractive force of the tile binder can also with advantage be effected by shortening/lengthening the straight section in between the bends in the zig-zag part in the elasticity-providing area.

[0023] The tile binder according to the invention can with advantage consist of a piece of stiff, round wire, with a yield stress within the interval of 1400-1800 N/mm².

[0024] The tile binder can also with advantage consist of a piece of stiff, round wire with a diameter lying within the range of 1.0 - 4.0 mm, typically within the interval 1.5-3.0 mm, and typically within the interval 1.7-2.2 mm.

[0025] With the tile binder according to the invention, savings can be achieved in wire due to the increased, better anchoring ability which is achieved by changing the engagement point of the tile binder in the boss. In accordance with future EU standards, the presently prescribed wire diameter of 3.0 mm for tile binders of the known type can thus be reduced to a diameter of between 1.8-2.2 mm, whereby a saving in wire right up to 50% could be achieved.

[0026] In the following, the invention will be explained in more detail with reference to the drawing, where

Fig. 1 is a side view of a tile binder of the kind used in roof constructions with sub roof, where the same is shown inserted in a roof construction,

Fig. 2 is an end view of a pantile,

Fig. 3 is a side view of a tile binder according to the invention, and the same inserted in a roof construction with sub roof, and

Fig. 4 illustrates the laying of a tile provided with a tile binder according to the invention.

[0027] Fig. 1 shows one of the tile binders which are typically used for anchoring tiles on roof constructions with sub roof (not shown, but cf. fig. 3). Such a binder consists of a piece of stiff, round steel wire with a strength of 16-1800 N/mm², and which typically has the shown configuration.

[0028] The shown, known tile binder 2 comprises a straight, free insertion part 4 for insertion from the lower end of the tile in the hole 3 (cf. fig. 2) in the binding boss 5 of a tile 6, and an end part 8 for anchoring to a rafter 10, and an approximately curved middle section 12 in between said parts, beginning with an approximately right-angled bend 14 followed by two successive 45° bends 16, 18, and terminated with a bending-over 20 of the wire end in against itself to form an end part 8 which will not be able to damage the sub roof by penetration. With this configuration, the roof-tile binder 2 can thus be mounted extending around the laying boss 7 on the underlying tile 22 and the rafter 10. Moreover, the laying boss 7 will be able to prevent the tile binder from falling out, in that with a downwards-directed displacement of

the binder 2, the right-angle bend 14 will abut up against the front edge of the laying boss 7 before the insertion part is displaced out of the boss 5.

[0029] However, the shown, known tile binder 2 is very sensitive to incorrect rafter dimensions, which means that the anchoring becomes poor if the rafters are too small, and rafter dimensions which are too great can result in wear damage occurring on the sub roof. Moreover, rafter dimensions which are too great can result in the straight free insertion end 4 of the binder placed in the boss 5 giving rise to an undesired, outwards-directed force being applied to an upper end 24 of the tile 6, indicated by the arrow 26, this being a consequence of the gripping end part 8 being placed at a greater distance from the underside 28 of the tile than the displacement which is provided by the bends 14, 16, 18 in the middle section 12. The outwards-directed force 26 arises by the insertion part 4, which is housed in the hole 3 (cf. fig. 2) in the tile's boss 5, being turned so that the outer end of the gripping end part 4 exercises an outwards-directed pressure on the boss 5 and herewith the tile 6, the lower underside 28 of which is hereby pressed more firmly against the underlying tile 22, whereby the contact pressure of the tile's upper end on the overlying rafter 30 is considerably reduced as a result of the outwards-directed influence 26 from the roof-tile binder.

[0030] Fig. 3 shows a roof-tile binder 40 according to the invention, respectively before and after insertion in a roof construction with sub roof 102. The roof construction also comprises underlying rafters 100, on the upper side of which the sub roof 102 is laid, for example in the form of a strong plastic foil. The sub roof is secured by a spacing batten 104 which is fastened to the outer side of the rafters. In fig. 3, these components 100, 102, 104 are for the sake of clarity shown with spaces between them, but in practice they will be in abutment with one another. Rafters 110 are placed on the outside of the spacing battens at mutual intervals which are selected to suit the tiles 6 which are to be laid on the roof construction. The inner sides 112 of the rafters are in abutment with the spacing battens 104, and the outer sides 114 of the rafters are in abutment with the tiles 6. The rafters also have an upper side 116 and a lower side 118.

[0031] In the shown embodiment, the roof-tile binder 40 consists of a piece of stiff, round steel wire, typically with a yield stress lying in the range of 1400-1800 N/mm². The tile binder 40 comprises an insertion part 42 which consists of the free end of an inverted U-shaped bending 44 of the one end of the middle section 46. It is hereby achieved that the insertion part 42 can be inserted in the hole 3 from the upper end 45 of the boss 5. At least a part of the bottom section 46 of the U-shaped bend 44 is hereby brought into abutment with the upper end surface 45 of the boss.

[0032] The roof-tile binder also comprises a section 48 which comprises an elasticity-providing part 50 which allows an elastic extension of the distance between the

bottom section 46 of the U-shaped bend 44 and a gripping end part 52 which preferably consists of a U- or V-shaped bending over of the free end 54 of the section 48. The gripping end part 52 is intended for fastening to the underside 118 of the rafter 10 at the foot of the tile.

[0033] The elasticity-providing part 50 of the section 48 can be configured in different ways, but without waiving other configurations, the preferred embodiment shown here can consist of two successive zig-zag bends (W-shaped bending) of the middle section 48. The possibility is hereby provided for an elastic increase in the length of the middle section when placing the gripping end part 52 of the tile binder on the underside 118 of the nearest lying rafter 110, in that a pull on the gripping end part will result in a stretching at the angle bends 56, 58, 60 in the zig-zag-bent area.

[0034] The configuration of the insertion part 42 as the free end of a U-shaped insertion part 44 enables the insertion part 42 to be inserted in the through-going hole 3 in the boss from the upper end 45, whereby at least a part of the bottom section 46 of the U-shaped bend 44 abuts up against the upper end surface 45 of the boss. This, in combination with the gripping end part 52, which when the tile 6 is being laid is brought into engagement with the underside 118 of the rafter 110, results in a considerable improvement of the anchoring of the tile 6 to the underlying roof construction. The reason for this is that when the tile binder is mounted in the boss 5, with the changed point of engagement in the tile's upward-facing side 45, there is achieved a resulting force on the tile 6 which in relation to the surface 62 of the tile is in an inclined downwards direction (indicated by the arrow 64), regardless of deviations in the dimensions of the rafter 110, on the underside 118 of which the gripping end part 52 of the tile binder is anchored, in that compensation is made for these deviations by the elasticity-providing part 50. With use of the tile binder according to the invention, the upper end 24 of the tile will hereby always be secured by the force directed towards an underlying rafter 30.

[0035] With rafters which are too large, it is thus achieved, unlike with the known tile binder cf. the above, that the downwards-directed tractive force on the tile is increased with subsequent increase in the stability of the roof. With rafters which are too small, it is achieved merely that the force is reduced, though not more than the said inclined downwards-directed force can be maintained. Consequently, when use is made of the tile binder according to the invention, no outwardly-directed force which could give rise to the roofing tiles becoming unstable is applied to the upper end of the tile under any positioning/building-in/mounting conditions whatsoever.

[0036] Moreover, the tile binder 40 according to the invention has the further advantage that it can be used together with rafters of different dimensions. Practical tests with the tile binder according to the invention have thus shown that this can be used together with rafters

of three different dimensions (30/50, 50/50 and 40/60), which is not possible with the known tile binders where a specific type of binder must be used with rafters of specific dimensions.

[0037] In fig. 4 it is shown how a tile 6 provided with a binder 40 according to the invention is laid on rafters 110. The tile 6 is laid after insertion of the insertion end 42 in the hole 3 in the boss 5, with the binder hanging down under the tile, after which the tile is tilted down so that the laying boss 7 at the upper end of the tile is brought into abutment with the outer side 114 of the overlying rafter 110. In the tilting movement, the obtusely-extending free end 54 of the gripping end part 52 is turned in behind the underside 118 of the rafter 110 at the foot of the tile, after which the tile is pushed slanting upwards in the direction of the arrow 120 until the tile's laying boss 7 passes the edge of the upper side 116 of the rafter, whereby the underside 28 of the tile is brought to rest against the outer side 114 of the rafter 110, and the underside 9 of the laying boss 7 is in abutment with the upper side 116 of the rafter. At the same time with said displacement of the tile 6, there occurs a displacement of the binder 10, whereby the free end 54 of the gripping end part 52 is now brought into abutment with the underside 118 of the rafter 110 at the foot of the tile. With continued displacement of the tile towards its final position, a tractive force in the longitudinal direction is applied to the elasticity-providing part 50, which results in a downwards-directed pull on the tile 6.

[0038] Before the roof-tile binder is mounted, the angles A, B, C, D in the zig-zag bends 56, 58, 59, 60 lie within the range of 60-120°, typically within the interval 80-110° and typically between 85-90°.

[0039] The length of the tile binder is selected so that when the binder is mounted, the angles A, B, C and D of the bends 56, 58, 59, 60 in the elasticity-providing part 30 are greater than 90°, whereby it is achieved that the tile binder 40 according to the invention exercises sufficient downwards-directed force 64 on the tiles 6, whereby the necessary anchoring of the roof is ensured.

[0040] Moreover, in the production of the roof-tile binders 40 according to the invention, it will be possible to effect an adjustment of the flexibility and tractive power of the binder 40 by shortening/lengthening the sections 66, 68, 70, 72, 74 in between the bends in the zig-zag section in the elasticity-providing area 50.

[0041] With the view to achieving a suitable anchoring of the bent-over free end 54 at the gripping end part 52, it can be mentioned that the directional deviation of the bend in relation to the straight extent of the anchoring part can form an angle E within the interval of 90° - 225°, typically between 110° - 200° and preferably within the interval of 120° - 190°. The free end can also be rounded-off, flattened or pointed with the view to providing a preferred grip in the underside 118 of the rafter.

[0042] With the roof-tile binder 40 according to the invention, a saving in wire can be achieved due to the increased, better anchoring ability which is obtained by

changing the point of engagement of the roof-tile binder in the boss 5. In accordance with future EF standards, a reduction will thus be able to be made in the presently prescribed wire diameter of 3.0 mm for tile binder of the known type to a diameter of 1.8-2.2 mm, whereby a saving in wire of right up to 50% will be able to be achieved.

[0043] With the invention, there is thus disclosed a new roof-tile binder which, in addition to eliminating the disadvantages connected with the use of roof-tile binders of the known type, is also resource-saving in production and herewith cheaper to produce.

[0044] The inventor has acknowledged that the roof-tile binder according to the invention can assume other configurations. The elasticity-providing element 50 could thus be configured as a spirally-wound spring, and the section between the insertion part 42 and the gripping end part 52 could also be of other configurations. Moreover, it is also envisaged that the binders could be configured in materials other than metal (steel wire), and the material could be of cross-sections other than circular (which is that which the steel wire normally has), but which, however will place requirements on the configuration of the tile where the opening for the insertion of the binder is concerned. Combinations of cross-sectional shapes and materials could also be envisaged.

[0045] This does not, however, change the basic concept of the invention, which is based on the provision of a roof-tile binder for use in the laying of tiles on roof constructions with sub roof, which has considerably increased the strength of the anchoring of the tiles in comparison to that which has hitherto been possible to achieve with roof-tile binders currently used for roof constructions of this type. This is effected by making use partly of the technique disclosed in DK patent no. 252898, where the insertion of the roof-tile binder's insertion part takes place from the upper side of the boss, combined with the establishing of a suitable gripping end part 52 with a free end 54 which can easily be brought into engagement in the underside 118 of the rafter at the foot of the tile, and furthermore by giving the length of the roof-tile binder an elasticity-providing part which, when the tile is laid, is tensioned and herewith subsequently gives rise to a constantly-applied downwards-directed force on the tile in towards the rafters 110, hereby achieving a considerably better anchoring of the tile to the underlying supporting roof construction.

50 Claims

1. Method for the laying and anchoring of tiles (6) on roof constructions with sub roof, **characterised in that** the insertion part (42) of a roof-tile binder (40) with a substantially U-shaped insertion part (44), a section (46) with an elasticity-providing part (50), and a gripping end part (52) with a U- or V-shaped bend, is inserted in the through-going hole in the

tile's binding boss (5) or similar insertion opening from the upper end of the binding boss, followed by the placing of the tile (6) with the foot on the upper side of the underlying tile (22), after which the tile is tilted down so that the tile's laying boss (7) is placed on top of the rafter (110) at the top of the tile, whereby the free end (54) of the gripping end part (52) is turned in behind the underside (118) of the rafter (110) at the foot of the tile, whereupon the tile (6) is pushed upwards, whereby the free end (54) of the gripping end part is brought into abutment with the underside 118 of the rafter 110 at the foot of the tile, and whereby a further displacement of the tile (6) gives rise to a stretching of the binder's elasticity-providing part (50), with the laying boss (7) sliding on the outer side (114) of the rafter (110) at the top of the tile until the front end of the tile falls down on the outer side (114) of the rafter, and rests on this with the back (9) of the laying boss (7) in abutment with the upper side (116) of the rafter, whereby the tile is secured.

2. Roof-tile binder (40) for use in the execution of the method according to claim 1, and comprising a body of stiff but still outwardly-flexible material, comprising a substantially inverted U-shaped insertion part (42, 44) for insertion from above in the binding boss (5) in a tile (6) or similar insertion opening, said insertion part (42) comprising via a bottom part (46) an elasticity-providing part (50) in both the longitudinal and transverse direction of the tile which stands in connection with an anchoring part (48), **characterised in that** the anchoring part (48) comprises a substantially straight section with a free end (54) which ends in a U- or V-shaped bend (52) for engagement in the underside (118) of the rafter (110) nearest to the foot (lower end) of the tile, said bend (52) extending in substantially the same plane as the inverted U-shaped insertion part (44).
3. Roof-tile binder (40) according to claim 2, **characterised in that** the directional deviation of the bend (52) in relation to the straight section of the anchoring part (48) forms an angle within the interval 90° - 225° , typically between 110° - 200° and preferably within the interval 120° - 190° .
4. Roof-tile binder (40) according to claim 2 or 3, **characterised in that** the obtuse end (54) of the bend (52) is flattened, thus forming a pressure surface with an area which is greater than the cross-sectional area of the obtuse part.
5. Roof-tile binder (40) according to any of the claims 2-4, **characterised in that** the obtuse end (54) of the bend (52) is pointed.
6. Roof-tile binder according to any of the claims 2-5,

characterised in that bottom section (46) extends in a substantially curved manner in between the insertion part (42, 44) and the gripping end part (52).

7. Roof-tile binder (40) according to any of the claims 2-6, **characterised in that** the curved extent of the bottom section (46) is given as a bend in the plane of the U-shaped insertion part (44) oriented in towards the insertion part (42), followed by an oppositely-directed bending of the section (46), and thereafter a substantially straight piece leading to an elasticity-providing part (50), which at its end comprises an angle before a straight part (48) which ends in a gripping end part (52) with a bent-over obtuse projecting free end in substantially the same plane as the U-shaped insertion part (44).
8. Roof-tile binder (40) according to any of the claims 2-7, **characterised in that** the elasticity-providing part (50) in the section (46) consists of at least one zig-zag bend (50) and preferably two consecutive zig-zag bends.
9. Roof-tile binder (40) according to claim 8, **characterised in that** the angles in the zig-zag bends in the binder's unmounted state lie within the range of 60 - 120° , preferably within 80 - 110° and typically between 90 - 100° .
10. Roof-tile binder (40) according to claim 8 or 9, **characterised in that** its length is selected so that when the tile binder is mounted, the angles in the angle bends in the elasticity-providing part (50) are greater than 90° .
11. Roof-tile binder (40) according to any of the claims 8-10, **characterised in that** the adjustment of the flexibility and the tractive force of the binder is effected by shortening/lengthening the straight sections in between the bends in the zig-zag section in the elasticity-providing area (50).
12. Roof-tile binder (40) according to any of the claims 1-11, **characterised in that** it consists of a piece of stiff, round wire with a yield stress lying within the interval 1400 - 1800 N/mm².
13. Roof-tile binder (40) according to any of the claims 12, **characterised in that** it consists of a piece of stiff, round wire with a diameter lying within the interval 1.0 - 4.0 mm, typically within the interval 1.5 - 3.0 mm and typically between 1.7 - 2.2 mm.

55 Patentansprüche

1. Verfahren zum Legen und Verankern von Ziegeln (6) auf Dachkonstruktionen mit Unterdach, da-

- durch gekennzeichnet, dass das Einschubteil (42) eines Dachziegel-Verbinders (40) mit im Wesentlichen U-förmigem Einschubteil (44), einem Abschnitt (46) mit einem elastizitätsgebenden Teil (50) und einem Greifendabschnitt (52) mit einem U- oder V-förmigem Knie in das Durchgangsloch im Ziegelverbindungswulst (5) oder in eine ähnliche Einschuböffnung vom oberen Ende des Verbindungswulsts eingeschoben wird, gefolgt von dem Anordnen des Ziegels (6) mit dem Fuß auf der Oberseite des darunterliegenden Ziegels (22), woraufhin der Ziegel nach unten geneigt wird, so dass der Ziegelauflegewulst (7) auf der Oberseite des Sparrens (110) am oberen Ende des Ziegels zu liegen kommt, wodurch das freie Ende (54) des Greifendabschnitts (52) hinter die Unterseite (118) des Sparrens (110) am Fuß des Ziegels hineingedreht wird, woraufhin der Ziegel (6) nach oben geschoben wird, wodurch das freie Ende (54) des Greifendabschnitts in Anschlag mit der Unterseite (118) des Sparrens (110) am Fuß des Ziegels gebracht wird und wodurch eine weitere Verlagerung des Ziegels (6) Anlass zu einer Dehnung des elastizitätsgebenden Teils (50) des Verbinders gibt, wobei der Auflegewulst (7) auf der Außenseite (114) des Sparrens (110) am oberen Ende des Ziegels gleitet, bis das vordere Ende des Ziegels von der Außenseite (114) des Sparrens herabfällt und darauf in der Weise liegt dass sich die Rückseite (9) des Auflegewulstes (7) in Anschlag an der Oberseite (116) des Sparrens befindet, wodurch der Ziegel gesichert ist.
2. Dachziegel-Verbinder (40) für die Verwendung bei der Ausführung des Verfahrens nach Anspruch 1, der einen Körper aus einem steifen, jedoch noch nach außen flexiblen Werkstoff umfasse der ein Einschubteil (42, 44) im Wesentlichen in Form eines umgedrehten U aufweist, das von oben in den Verbindungswulst (5) In einem Ziegel (6) oder In eine ähnliche Einschuböffnung eingeschoben wird, wobei das Einschubteil (42) über ein Bodenteil (46) ein sowohl in longitudinaler als auch in transversaler Richtung des Ziegels elastizitätsgebendes Teil (50), das mit einem Verankerungsteil (48) in einer Verbindung steht, aufweist, **dadurch gekennzeichnet, dass** das Verankerungsteil (48) einen im Wesentlichen geraden Abschnitt mit einem freien Ende (54), das in einem U- oder V-förmigen Knie (52) für den Eingriff in der Unterseite (118) des Dachsparrens (110) in der Nähe des Fußes (des unteren Endes) des Ziegels endet, aufweist, wobei sich das Knie (52) im Wesentlichen in derselben Ebene wie das Einschubteil (44) in Form eines umgedrehten U erstreckt.
3. Dachziegel-Verbinder (40) nach Anspruch 2, **dadurch gekennzeichnet, dass** die Richtungsabweichung des Knies (52) in Bezug auf den geraden Abschnitt des Verankerungsteils (48) einen Winkel in einem Intervall von 90° bis 225°, typischerweise im Bereich von 110° bis 200° und vorzugsweise im Bereich von 120° bis 190° bildet.
4. Dachziegel-Verbinder (40) nach Anspruch 2 oder 3, **dadurch gekennzeichnet, dass** das stumpfe Ende (54) des Knies (52) abgeflacht ist, wodurch eine Druckoberfläche mit einer Fläche, der größer als die Querschnittsfläche des stumpfen Teils ist, gebildet wird.
5. Dachziegel-Verbinder (40) nach einem der Ansprüche 2 bis 4, **dadurch gekennzeichnet, dass** das stumpfe Ende (54) des Knies (52) zugespitzt ist
6. Dachziegel-Verbinder nach einem der Ansprüche 2 bis 5, **dadurch gekennzeichnet, dass** sich der Bodenabschnitt (46) in einer im Wesentlichen gekrümmten Weise zwischen dem Einschubteil (42, 44) und dem Greifendabschnitt (52) erstreckt.
7. Dachziegel-Verbinder (40) nach einem der Ansprüche 2 bis 6, **dadurch gekennzeichnet, dass** der Krümmungsverlauf des Bodenabschnitts (46) als eine Krümmung in der Ebene des U-förmigen Einschubteils (44) gegeben ist, die zum Einschubteil (42) gerichtet ist, gefolgt von einer entgegengesetzt gerichteten Krümmung des Abschnitts (46) und danach von einem im Wesentlichen geraden Teil, das zu einem elastizitätsgebenden Teil (50) führt, das an seinem Ende einen Winkel vor einem geraden Teil (48) aufweist, das in einem Greifendabschnitt (52) endet, das ein umgebogenes, stumpfes, vorstehendes freies Ende im Wesentlichen in derselben Ebene wie das U-förmige Einschubteil (44) besitzt.
8. Dachziegel-Verbinder (40) nach einem der Ansprüche 2-7, **dadurch gekennzeichnet, dass** das elastizitätsgebende Teil (50) in dem Abschnitt (46) im Wesentlichen aus einer Zickzack-Krümmung (50) und vorzugsweise aus zwei aufeinander folgenden Zickzack-Krümmungen besteht.
9. Dachziegel-Verbinder (40) nach Anspruch 8, **dadurch gekennzeichnet, dass** die Winkel der Zickzack-Krümmungen im nicht montierten Zustand des Verbinders im Bereich von 60° bis 120°, vorzugsweise Im Bereich von 80° bis 110° und typischerweise im Bereich von 90° bis 100° liegen.
10. Dachziegel-Verbinder (40) nach Anspruch 8 oder 9, **dadurch gekennzeichnet, dass** seine Länge so gewählt ist, dass bei montiertem Ziegel-Verbinder die Winkel in den Winkelecken in dem elastizitätsgebenden Teil (50) größer als 90° sind.

11. Dachziegel-Verbinder (40) nach einem der Ansprüche 8-10, **dadurch gekennzeichnet, dass** die Einstellung der Flexibilität und der Zugkraft des Verbinders durch Verkürzen/Verlängern der geraden Abschnitte zwischen den Ecken im Zickzack-Abschnitt in dem elaszitätsgebenden Bereich (50) erfolgt. 5
12. Dachziegel-Verbinder (40) nach einem der Ansprüche 1-11, **dadurch gekennzeichnet, dass** er aus einem Teil eines steifen, runden Drahts mit einer Streckgrenze im Bereich von 1400 bis 1800 N/mm² besteht. 10
13. Dachziegel-Verbinder (40) nach Anspruch 12, **dadurch gekennzeichnet, dass** er aus einem Teil eines steifen, runden Drahts mit einem Durchmesser im Bereich von 1,0 bis 4,0 mm, typischerweise im Bereich von 1,5 bis 3,0 mm und typischerweise im Bereich von 1,7 bis 2,2 mm besteht. 15

Revendications

1. Procédé de pose et d'ancrage de tuiles (6) sur des structures de toit munies d'un sous-toit, **caractérisé en ce que** la partie d'insertion (42) d'une frette de tuile de toit (40) munie d'une partie d'insertion sensiblement en forme de U (44), d'une section (46) avec une partie assurant une élasticité (50) et d'une partie d'extrémité d'accrochage (52) munie d'une partie courbée en forme de U ou V, est insérée dans le trou traversant du bossage de liaison de tuile (5) ou une ouverture similaire d'insertion à partir de l'extrémité supérieure du bossage de liaison, suivi du placement de la tuile (6) avec un pied sur le coté supérieur de la tuile sous-jacente (22), après quoi la tuile est basculée vers le bas de façon à ce que le bossage de pose de tuile (7) soit placé au sommet du chevron (110) sur le dessus de la tuile, l'extrémité libre (54) de la partie d'extrémité d'accrochage (52) étant ainsi tournée derrière le verso (118) du chevron (110) au pied de la tuile, la tuile (6) étant alors poussée vers le haut, l'extrémité libre (54) de la partie d'extrémité d'accrochage étant ainsi amenée en butée contre le verso (118) du chevron (110) au pied de la tuile et un déplacement supplémentaire de la tuile (6) entraînant ainsi un étirement de la partie assurant une élasticité (50) de la frette, le bossage de pose (7) coulissant sur le coté externe (114) du chevron (110) au sommet de la tuile jusqu'à ce que l'extrémité avant de la tuile tombe sur le coté externe (114) du chevron et repose sur ce dernier avec l'arrière (9) du bossage de pose (7) en butée contre le coté supérieur (116) du chevron, la tuile étant ainsi fixée. 20
2. Frette de tuile de toit (40) pour la mise en oeuvre du procédé selon la revendication 1, et comprenant un corps d'un matériau raide bien que flexible vers l'extérieur, comprenant une partie d'insertion sensiblement en forme de U inversé (42, 44) pour une insertion par en dessus dans le bossage de liaison (5) d'une tuile (6) ou une ouverture d'insertion similaire, ladite partie d'insertion (42) comprenant par l'intermédiaire d'une partie de fond (46) une partie assurant une élasticité (50) dans la direction à la fois longitudinale et transversale de la tuile qui reste en connexion avec une partie d'ancrage (48), **caractérisée en ce que** la partie d'ancrage (48) comprend une section sensiblement droite avec une extrémité libre (54) se terminant en une partie courbée en forme de U ou V (52) pour un engagement dans le verso (118) du chevron (110) le plus proche du pied (extrémité inférieure) de la tuile, ladite partie courbée (52) s'étendant sensiblement dans le même plan que la partie d'insertion en forme de U inversé (44). 25
3. Frette de tuile de toit (40) selon la revendication 2, **caractérisée en ce que** l'écart de direction de la partie courbée (52) par rapport à la section droite de la partie d'ancrage (48) fait un angle compris entre 90° et 225°, typiquement entre 110° et 200° et de préférence entre 120° et 190°. 30
4. Frette de tuile de toit (40) selon la revendication 2 ou 3, **caractérisée en ce que** l'extrémité obtuse (54) de la partie courbée (52) est aplatie, formant ainsi une surface de pression avec une zone qui est plus grande que la surface de section transversale de la partie obtuse. 35
5. Frette de tuile de toit (40) selon l'une quelconque des revendications 2 à 4, **caractérisée en ce que** l'extrémité obtuse (54) de la partie courbée (52) est effilée. 40
6. Frette de tuile de toit (40) selon l'une quelconque des revendications 2 à 5, **caractérisée en ce que** la section de fond (46) s'étend, d'une façon sensiblement incurvée, entre la partie d'insertion (42, 44) et la partie d'extrémité d'accrochage (52). 45
7. Frette de tuile de toit (40) selon l'une quelconque des revendications 2 à 6, **caractérisée en ce que** l'extension incurvée de la section de fond (46) est constituée d'une partie courbée dans le plan de la partie d'insertion en forme de U (44) orientée en direction de la partie d'insertion (42), suivie d'une courbure opposée de la section (46) puis d'une partie sensiblement droite conduisant à une partie assurant une élasticité (50), faisant à son extrémité un angle avant une partie droite (48) se terminant en une partie d'extrémité d'accrochage (52) avec une extrémité libre obtuse en projection dans sensiblement le même plan que la partie d'insertion en 50

forme de U (44).

8. Frette de tuile de toit (40) selon l'une quelconque des revendications 2 à 7, **caractérisée en ce que** la partie assurant une élasticité (50) dans la section (46) consiste en au moins une partie courbée en zigzag (50) et de préférence, en deux parties courbées consécutives en zigzag. 5
9. Frette de tuile de toit (40) selon la revendication 8, **caractérisée en ce que** les angles des parties courbées en zigzag dans l'état non monté de la frette s'étendent entre 60 et 120°, de préférence entre 80 et 110° et typiquement entre 90 et 100°. 10
15
10. Frette de tuile de toit (40) selon la revendication 8 ou 9, **caractérisée en ce que** sa longueur est sélectionnée de façon à ce que, lorsque la frette de tuile est montée, les angles des parties courbées angulaires dans la partie assurant une élasticité (50) soient supérieurs à 90°. 20
11. Frette de tuile de toit (40) selon l'une quelconque des revendications 8 à 10, **caractérisée en ce que** le réglage de la flexibilité et de la force de traction de la frette est effectué par raccourcissement/allongement des sections droites séparant les parties courbées de la section en zigzag dans la partie assurant une élasticité (50). 25
30
12. Frette de tuile de toit (40) selon l'une quelconque des revendications 1 à 11, **caractérisée en ce qu'elle** consiste en une pièce de fil arrondi raide avec une résistance au formage comprise entre 1400 et 1800 N/mm². 35
13. Frette de tuile de toit (40) selon l'une quelconque des revendications 12, **caractérisée en ce qu'elle** consiste en une pièce de fil arrondi raide avec un diamètre compris entre 1,0 et 4,0 mm, typiquement entre 1,5 et 3,0 mm et typiquement entre 1,7 et 2,2 mm. 40
45
50
55

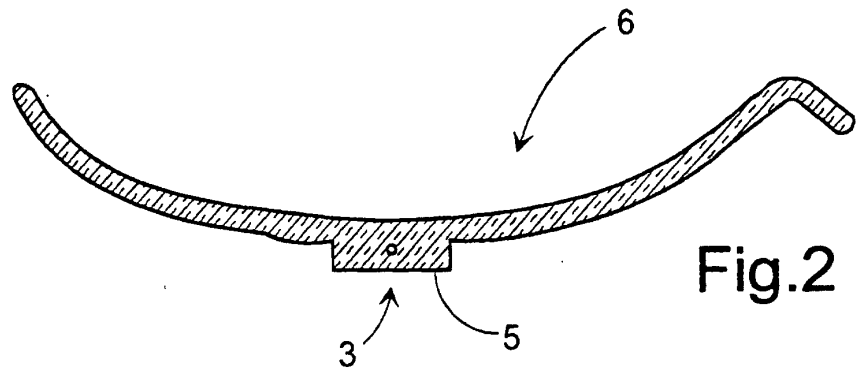
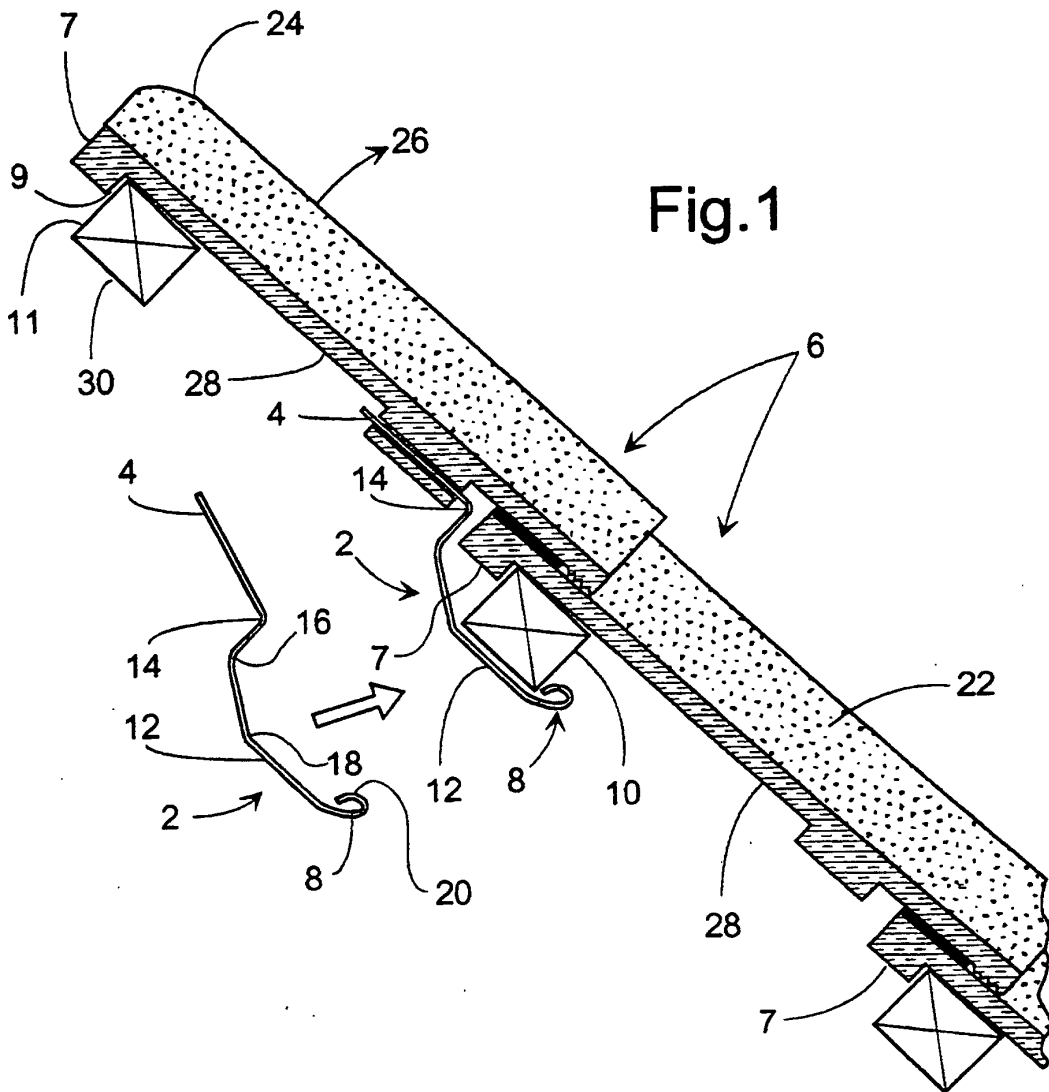

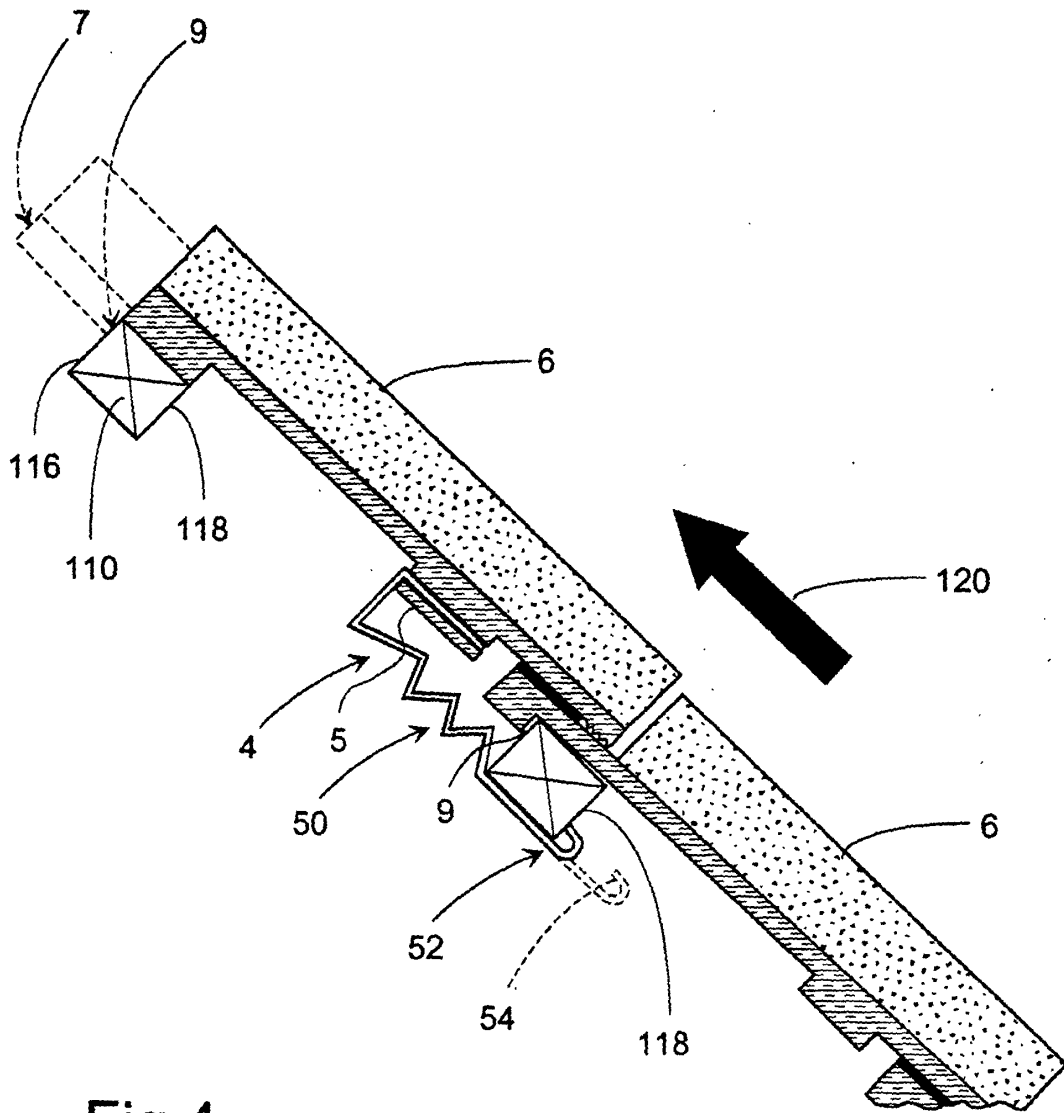

Fig.4