



(11)

EP 4 495 352 A1

(12)

EUROPEAN PATENT APPLICATION

(43) Date of publication:
22.01.2025 Bulletin 2025/04

(51) International Patent Classification (IPC):
E04F 15/02 ^(2006.01) **E04F 15/024** ^(2006.01)
E04F 15/10 ^(2006.01)

(21) Application number: **24188337.0**

(52) Cooperative Patent Classification (CPC):
E04F 15/02405; E04F 15/02172; E04F 15/02452;
E04F 15/02458; E04F 15/105; E04F 2015/0205;
E04F 2201/0138; E04F 2201/042

(22) Date of filing: **12.07.2024**

(84) Designated Contracting States:
AL AT BE BG CH CY CZ DE DK EE ES FI FR GB
GR HR HU IE IS IT LI LT LU LV MC ME MK MT NL
NO PL PT RO RS SE SI SK SM TR
Designated Extension States:
BA
Designated Validation States:
GE KH MA MD TN

(72) Inventors:
• **HUSS, Philip C.**
Smyrna, 37167 (US)
• **MOUGHLER, John**
Smyrna, 37167 (US)

(30) Priority: **18.07.2023 US 202318223142**

(74) Representative: **Plasseraud IP**
104 Rue de Richelieu
CS92104
75080 Paris Cedex 02 (FR)

(71) Applicant: **Wearwell, LLC**
Smyrna TN 37167 (US)

(54) **CUSTOMIZABLE TILE FOR MODULAR PLATFORM SYSTEM, MODULAR PLATFORM SYSTEM WITH CUSTOMIZABLE TILE, AND METHOD OF PLATFORM MAKING**

(57) A customizable tile is configured for use with a modular platform system that uses tiles, beams supporting the tiles, and legs supporting the beams. The customizable tiles include a tile sizing structure on an underside thereof. The tile sizing structure includes channels and cutting slots extending in different directions so that the channels and cutting slots intersect. The cutting slots

act as a guide to cut the tile to alter its width and/or length so that the tile has a customized size for use in the modular platform system. The channels are configured to receive a support board, if necessary, to provide support for the tile on the beams once the tile is cut to size. The channels can also connect to the beams for tile support if need be.

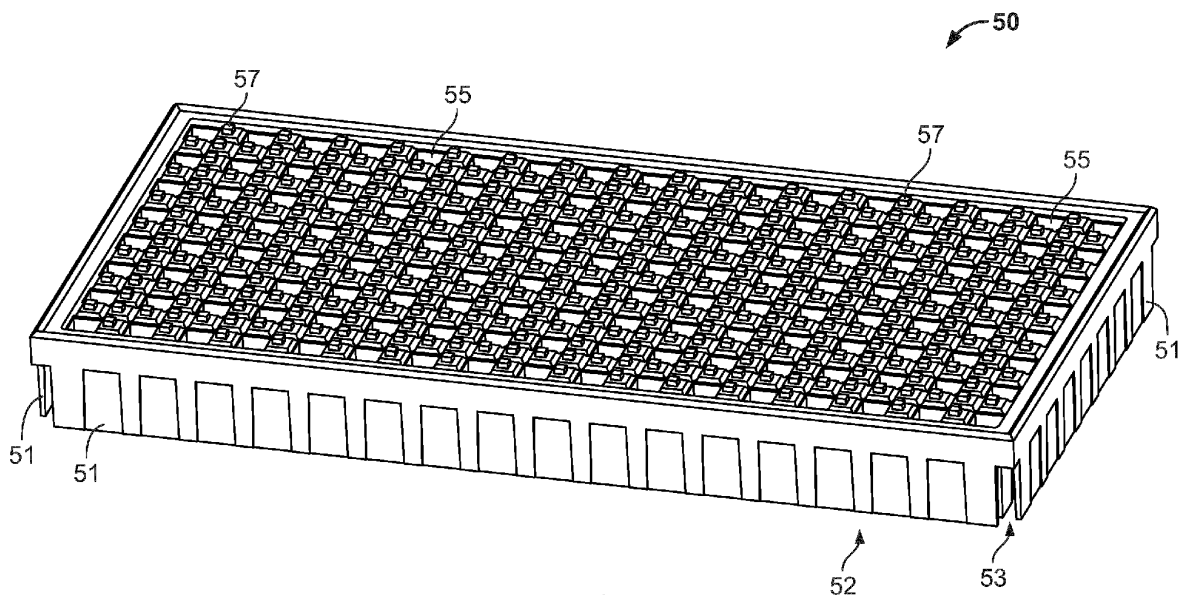

FIG. 6

EP 4 495 352 A1

Description

FIELD OF THE INVENTION

[0001] A modular platform system that uses tiles, beams, and legs, each being configured together to allow creation of differently-configured platforms in a simple fashion, uses a customizable tile that allows for precise size adjustment of a platform area of the modular platform system.

BACKGROUND OF THE INVENTION

[0002] Platform systems are known in the art. Patent Nos. 4,676,036 to Bessert, 6,256,952 to Fahy et al., 4,901,490 to Zinniel, 4,561,232 to Gladden, Sr. et al., 7,360,343 to Spransy et al, and 2,956,653 and 3,180,460 to Liskey Jr. are examples of such systems. However, these platform systems lack flexibility and ease in the ability to make differently-configured platforms using the same components. In general, these prior art systems are time consuming and inconvenient to create a desired platform, expensive, inflexible in accommodating different configurations, and are ad-hoc or special purpose in their design.

[0003] An improved platform system is also known, wherein the platform system uses specially-configured and modular components that permit the creation of differently configured platform systems using the same components. This platform system is described in Pre-Grant Publication No. 2022/0356718 to Huss et al. and is herein incorporated by reference in its entirety. Figure 1 shows an example of this platform system. More particularly, Figure 1 shows a perspective view of one arrangement of the modular components of the modular platform system. The modular platform system (hereinafter the platform system) is designated by the reference numeral 10. The platform system has a number of components that are used to assemble a completed platform system, some essential components to create a functional platform and some optional components used if the platform application requires such optional components.

[0004] The platform system 10 includes a plurality of tiles 1a and 1b and beams 3, 3'. The tiles 1a are open tiles and the tiles 1b are closed and smooth surfaced tiles. The tiles are designed to clip or snap onto the portions of the beams 3 for easy assembly and disassembly of the platform system. The beams 3, 3' are supported by legs 5. The beams 3, 3' and legs 5 are configured so that the legs 5 can be easily attached to the beams 3, 3'.

[0005] In one embodiment, the platform system 10 also includes brackets 7. The brackets 7 are configured to attach the legs 5 to the beams 3. The brackets 7 can also be used to secure a leg 5 to a ground surface if further securement of the platform system is required. Other means as would be known in the art can be used to secure the legs to the beams, e.g., a direct attachment of the leg to a beam without the need for the additional

bracket.

[0006] The beams 3 can be arranged to run in different directions for a given platform system. In Figure 1, the platform system has one section 9, which uses four beams 3' and twelve tiles, with the beams 3' of section 9 running along direction "X". Another section of tiles 11 uses three beams 3 and eight tiles. The beams 3 in tile section 11 run along direction "Y", which is perpendicular to the direction "X" for beams 3' in tile section 9. The two sets of beams 3, 3' can be attached in one way using the brackets 7.

[0007] In alternative and not shown in Figure 1, the legs of each tile section 9 and 11 could be attached to the floor so that there would be no need for a connection between support beams of adjacent tile sections 9 and 11. The tile sections 9 and 11 would stand alone from each other but still be located next to each other to provide a continuous upper surface for the platform system. By using just the legs to support different platform sections of a platform system, the beams could run in different angled directions rather than just 90 degrees as shown in Figure 1. One set of beams could be angled at 30 or 45 degrees, for example, to another set of beams.

[0008] The platform system 10 can also include cross beams 13. The cross beams 13 and legs 5 are configured so that one cross beam 13 can attach between adjacent legs 5. More particularly, the free end of tile section 11 has three legs 5 and two cross beams 13, each cross beam 13 arranged between adjacent legs 5. With the placement of the cross beams 13, the legs 5 are further stabilized against movement and shifting when the weight or other forces are applied to the platform. Preferably, the cross beams are made of the same material as the beams and legs. However, since the cross beams do not see the loads that the beams and legs see, other materials for the cross beams can be employed, e.g., non-metallics like polymers.

[0009] The platform system can also include a ramp 15, the ramp designed to attach to a beam 3, preferably in a similar manner as the attachment between the beams 3, 3' and tiles 1a and 1b. The ramp allows for platform system use by a user that cannot handle walking up or down steps and/or allows items to be rolled up to the platform upper surface or down therefrom. The ramp can be made of any material that would provide the strength to support a worker traveling up or down the ramp and any items that may be rolled up or down the ramp. A metal ramp is preferred as this would provide the desired strength but high strength polymers, composites, and the like could also be used.

[0010] Another feature of the platform system is the use of hand railing 17. The hand railing can be configured to attach to the platform in any manner, and preferably to one or more legs, beams or other platform system components. The handrail 17 can be positioned with respect to the tile section 9 of tiles forming a floor of the platform system. While the railing 17 is shown associated with tile section 9, it can be associated with other sections of tiles

or multiple railings could be used depending on the location of the platform assembly and need to the presence of a railing for safety purposes.

[0011] The legs 5 can be made of the same material as the beams 3, 3' and also provided in a standard length, e.g., six feet. With this standard length, the legs can then be cut to length to provide a given platform system with tiles at different elevations. A six foot length of leg could provide six 1 foot sections for platform use, for example. Of course, the legs 5 could be supplied in lengths specified by a customer for a particular platform system as well.

[0012] Typically, the beams 3 would be made in six foot lengths as shown in tile sections 9 and 11 and this six foot length would accommodate four tiles that are 18 inches square. For the step 19, the legs are shortened in length as are the beams 3, with the beams being roughly 54 inches to accommodate a run of three 18 inch on side tiles 1b.

[0013] An example of the one type of adjustable height feature of the legs is shown in the platform system 10 of Figure 1. In this system, a number of tiles 1b, beams 3", smaller height legs 5', cross beams 13, and brackets 7 are employed to create a step designated by the reference numeral 19. It can be seen that the beams 3, 3' for tile sections 9 and 11 are one length (the equivalent of four tiles in length) and the beams 3" that form the step 19 are shorter in length (three tiles in length). The construction of the step 19 illustrates the flexibility of the platform system as the same beams and legs that are used for each tile section 9 and 11 can be used to create step 19; just that the beams and legs are cut and reduced in length to form the step 19. This length flexibility in both the legs and beams allows a wide variety of elevations for a platform system or within a platform system and a wide variety of the arrangement of the tiles for a given platform system.

[0014] Yet another feature of the platform system is the use of trays 21, which are used in the tile section 11 of the platform system 10. The trays 21 are positioned beneath the open tiles 1a to collect any debris or other items that may fall onto the open tiles and pass therethrough. The trays 21 and beams 3 are also configured to allow the trays 21 to slide along a surface of the beams 3 to be positioned beneath the tiles 1a. The trays 21 could be sized to match the size of a given tile or be longer in length. In Figure 1, a set of two trays (four trays in total) are shown beneath each of the longitudinally or Y-direction-aligned four tile sets of tile section 11. The trays can be made of any material, metal or non-metallic, but a preferable construction would be non-metallic, e.g., a polymer that could be easily molded into the tray shape and be inexpensive and light weight.

[0015] Another feature of the platform system is the use of toe boards, which are designed as a barrier along the peripheral edge of the platform to prevent items from rolling off the platform surface. One configuration of toe boards is shown in Figure 1 as 23 and the other as 23' for

closed tile section 9. The toe boards 23 and 23' are configured to abut an outer edge of a run of tiles and extend above the tile surfaces to prevent items that may be on the tile surface or dropped thereon from rolling off the platform. In one mode, the toe board 23 can attach to the beams 3. In other mode, the toe boards could be secured to the platform using the legs 5. The modes of attachment are only exemplary and other modes of attachment could be used as long as the attachment positions a portion of the toe board above the tile surfaces. The toe boards could be made of any material, either metallic or non-metallic. As with the trays, a preferred material would be a durable polymer that would have sufficient strength to take impact from workers or other items on the platform surface that may come into contact with the toe board. An example of this material would be a high density polyethylene.

[0016] The platform system 10 can include different designed tiles, one of which is shown in Figure 2a as a tile, with a number of openings 2 therein. The open tile design shown is only an example of the types of openings employed and other opening designs could also be used for the tile 1a. The tile could also have a closed top surface as well.

[0017] Figure 3 shows an enlarged view of a portion of the tile of Figure 2 and its tile periphery 25. The tile periphery 25, that is, all four sides of a given tile, has a slot 27 along each side. The slot is formed by a side face 26 of the tile 1a and a peripheral member 29 that extends from an upper portion 32 of the tile 1a. The member 29 has an enlarged portion 31, which creates a bias against an adjacent surface fitted into the slot 27 so that a clipping or snap on action is obtained when the tile 1a is attached to a beam 3. The tile 1a also includes an underside surface 33 that also engages a surface of the beam 3 for tile support.

[0018] The beam 3 has an elongate shape and a profiled cross section that provides a number of different functionalities for the assembly and stability of the platform system. Figure 4a shows a portion of the beam 3 in perspective view and Figure 4b shows a sectional view of the beam 3. Preferably, the beam 3 is one that is extruded from an aluminum alloy for ease of making the desired profile. Using aluminum as the material of the beam allows for the use of a high strength aluminum alloy such as from one from the 6000 series alloys.

[0019] An upper portion 33 of the beam 3 includes a pair of upright members 35. The upright members 35 form a channel 37. Laterally outside of the upright members 35 and channel 37 are a pair of supporting surfaces 39. The upright members 35 and channel 37 interface with the periphery 25 of the tile 1a to allow the tile 1a to easily snap into place on the arrangement of beams for any given platform system as is detailed below.

[0020] One example of a connection arrangement between a beam and tiles is illustrated in Figure 5. The location of this particular arrangement is designated by the reference numeral 30 in Figure 1, which is a front view

of the free end of the tile section 11. In the tile and beam connection, each member 29 of each tile 1a engages the channel 37 formed between the two upright members 35 of the beam 3. At the same time, each upright member 35 engages the slot 27 in each tile periphery 25. Because of the shape of the members 29 and enlarged portion 31 thereof, the members 29 snap in or clip to the beam 3 to provide a tight connection between tile and beam. That is, the member 29 is biased against an inside surface of the channel 37 between the upright members 35 of the beam 3. Since the connection is primarily made using the clip action described above, the tiles are also easily removed from the beams by lifting the tile with enough force to disengage the upright members 35 of the beam 3 from a slot 27 in the tile periphery 25.

[0021] One drawback of the platform system of Figure 1 is the configuration of the tiles 1a and 1b. Typically, the tiles are made of aluminum and are not easily customizable to precisely adjust the area of the platform for a desired use. The aluminum nature of the tiles make them difficult to cut to a desired size and there is really no easy way to resize the tile in an easy and efficient manner.

[0022] In light of these drawbacks, there is a need to provide an improved tile design that permits precise area adjustments for the platform.

[0023] The present invention responds to this need by the creation of a customizable tile and tile assembly that allows the tile to be altered in size to allow for the use of precisely sized tiles for platform construction.

SUMMARY OF THE INVENTION

[0024] One object of the invention is to provide an improved modular platform system, including one that uses a customizable size tile.

[0025] Another object of the invention is to provide a customizable tile that can be used in existing platform systems.

[0026] A further object of the invention is to provide the customizable tile with one or more support boards that can be used to support the tile once cut to a different size.

[0027] The invention also provides an improved way to create the modular platform systems by allowing tile sizing to be done at the site of the platform system creation, thereby allowing changes in the platform size from that originally contemplated.

[0028] Other objects and advantages will be apparent from the detailed description of the invention provided below.

[0029] For the customizable sized tile embodiment of the invention, the tile includes a top portion and a tile periphery, the tile periphery including peripheral members therearound. A tile size adjusting structure forms part of the tile, the tile size adjusting structure extending from an underside of the top portion. The tile size adjusting structure also has a periphery and the tile size adjusting structure periphery and the peripheral members form a peripheral slot inward of the peripheral members for tile

attachment purposes. The tile size adjusting structure further includes a plurality of channels extending in first and second directions, and a plurality of cutting slots also extending in the first and second directions. The channels and cutting slots extending in the first direction intersecting with the channels and cutting slots extending in the second direction. For channels and cutting slots extending in the same direction, each channel is positioned between a pair of cutting slots, cutting along one or more of the cutting slots allowing the dimension of the tile to be reduced.

[0030] While the tile can be made of any material that provides the necessary strength when used in a modular platform system, a preferred material is a polymeric material as such materials are easier to cut than metals such as aluminum.

[0031] While the channels can be formed by various configurations of the tile sizing structure, one embodiment uses opposing discontinuous walls to form the channels, each discontinuous wall having spaces to accommodate intersecting channels and intersecting cutting slots. In this embodiment, each cutting slot is formed by one of the opposing discontinuous walls used for channel formation and a second discontinuous wall.

The second discontinuous wall is formed by wall segments of the opposing discontinuous walls that form channels that intersect the cutting slot.

[0032] The corners of the periphery of the tile size adjusting structure includes I-shaped wall segments, such I-shaped wall segments cooperating in forming the peripheral slots adjacent the peripheral members of the tile.

[0033] The tile top portion can have virtually any configuration, including one with openings therethrough and one with a top surface that is closed and has no openings. The top surface of the tile, with openings or not, can include traction means as raised portions on the top surface or recesses therein to provide traction for movement by a user or objects on the top surface.

[0034] The invention also includes the customizable tile in combination with at least one support board, the at least one support board sized to fit into one of the channels. The support board provides additional support for the tile once it is cut down in size. Like the tile, the support board can be cuttable so that the at least one support board that can fit into a channel whose length is changed by cutting of the tile along one of the cutting slots thereof.

[0035] Another embodiment of the invention is the use of the tile as an improvement in known modular platform systems that use tiles, beams, and legs, wherein the tiles are supported by the beams and the beams are supported by the legs. The modular platform system can also include one or more support boards if cutting of the tiles requires their use.

[0036] Yet another aspect of the invention is an improved way to create a modular platform system. Unlike prior art systems where tile sizes need to be customized and the tiles had to be cut by the platform system provider,

the customizable tiles allow creating the modular platform system on site by assembling of the tiles, beams, legs, etc., and at the same time, allowing the tile to be cut to the desired size on site. With this capability, if the original layout of the platform should change from that provided by the platform system provider, the changes in tile size can be easily made at the site of platform installation. This method of creating the modular platform system could also include use of the support boards and cutting thereof if required for tile customization.

BRIEF DESCRIPTION OF THE DRAWINGS

[0037]

Figure 1 shows a prior art modular platform system in perspective view.

Figure 2 shows a perspective view of the kind of tile used in the platform system of Figure 1.

Figure 3 shows an enlarged portion of a periphery of the tile of Figure 2.

Figures 4a and 4b shows views of the beam used in the platform system of Figure 1.

Figure 5 shows a front view of a connection of two tiles and a beam from the platform system of Figure 1.

Figure 6 shows a perspective view of the top side of one embodiment of the inventive tile, with openings in the top portion of the tile.

Figure 7 shows a perspective view of the top side of another embodiment of the inventive tile, with top portion of the tile being closed and relatively smooth surfaced.

Figure 8 shows an underside perspective view of the tile of Figure 6.

Figure 9 shows a schematic representation of the underside of the tile of Figure 6.

Figure 10 shows a view along the line X-X of Figure 9.

Figure 11 shows a view along the line XI-XI of Figure 9.

Figure 12 shows a perspective view of a support board for use with the tile of Figure 6.

Figure 13 shows an underside perspective view of the tile of Figure 6 with a pair of support boards attached thereto.

Figure 14 shows another schematic representation of the underside of the tile of Figure 6, with a different sizing arrangement as compared to that described in connection with Figure 9.

DETAILED DESCRIPTION OF THE INVENTION

[0038] Figure 6 shows one embodiment of the inventive tile in top perspective view. The tile is designated by the reference numeral 50 and includes peripheral members 51 that form a tile periphery and a slot 53 disposed along an inner face of each peripheral members 51. The members 51 and slot 53 function in the similar manner as

the peripheral member 29 and slot 27 shown in Figure 3 of the platform system described above. That is, the peripheral member 51 is configured to fit within a slot like the slot 37 of the beam 3 of Figure 4B.

[0039] The tile 50 is shown with an open top configuration, wherein a top portion of the tile has a series of openings 55 that allow debris, water, and the like to drop through the tile 50 and not accumulate on a surface thereof. The solid portions of the top portion surrounding or adjacent to the openings 55 are shown with a protrusion 57 to improve traction when a user is walking on the tile. Of course, other configurations can be used for the solid portions of the top portion.

[0040] Figure 7 shows an alternative tile configuration to tile 50, designated as 50'. The tile 50' has a solid top portion 59 with intersecting slots 61 in the top portion 59 for traction purposes. While slots are shown, which are recessed portions in a top surface of the top portion, protrusions or raised portions can also be employed for traction purposes. Further, raised and recessed portions can be combined for traction purposes as well. These traction options could also apply to top surface portions of the tile 50 has openings therethrough.

[0041] Figure 8 shows a perspective view of the underside of the tile 50. As will be described in more detail below, the underside of the tile has tile sizing structure extending from the top portion 59 that creates a number of channels and cutting slots. The channels and the cutting slots both run longitudinally in an x direction and transversely in a y direction so as to be intersecting with each other. That is, the channels and cutting slots that run in a first direction, e.g., an x-direction, intersect with channels and cutting slots that run in a second direction, e.g., perpendicular to the first direction, a y-direction.

[0042] The tile 50 also includes a tile sizing structure is designated by reference numeral 54. This tile sizing structure also includes its own periphery that forms one of the faces of the slot 53. This peripheral face is described in more detail below in connection with Figure 11.

[0043] The cutting slots are used to customize the size of the tile to fit in a given modular platform system. More particularly, the cutting slots provide a guide so that the tile can be cut either longitudinally (x direction), transversely (y direction) or in both x and y directions, the number of cuts and placement thereof dependent on the final customizable size of the tile.

[0044] The channels are sized to accommodate members to provide support along the length or width of the tile once is customized in size. The channels can also function to attach to a beam of a platform system and this functionality is described in more detail below.

[0045] The intersecting nature of both the channels and the cutting slots allows the tile to be cut in a number of different configurations for optimum flexibility in determining a final width and length of the tile when customized in size and still provide the needed support when

used in a modular platform system.

[0046] In one embodiment, the channels are formed by a pair of discontinuous walls, with the channel disposed therebetween. Since the channels run both longitudinally and transversely, the walls forming the channels are discontinuous to allow for the channels to traverse both the width and length of the tile for customizing of tile size. It should be understood that a discontinuous wall is a wall having discontinuities along a length thereof. The actual walling feature is maintained in spite of the discontinuities or spaces along the length of the wall as the wall is made of up spaced apart portions, the spaced apart portions forming the discontinuities, with the spaced apart portions extending from an underside of the top portion of the tile and aligned in a given direction to form a wall-like structure for formation of the channels and cutting slots.

[0047] The cutting slots are formed using discontinuous walls. In the illustrated embodiment, one of the discontinuous walls that form a given channel is used to form a wall of a given cutting slot. Another discontinuous wall that cooperates to form the cutting slot is formed by wall segments of the discontinuous walls that form channels running perpendicular to the direction of the given cutting slot.

[0048] Figure 9 shows a schematic view of an underside of the tile to better illustrate the channels, the cutting slots, the discontinuous walls forming the channels, and the discontinuous wall and wall segments forming a given cutting slot.

[0049] The peripheral members 51 and slots 53 are shown surrounding the inner tile sizing structure 54 that forms the channels and cutting slots. The channels running in the x direction are designated by the reference numeral 63a-p, and the channels running in the y direction are designated by the reference numeral 65a-g.

[0050] Taking y-direction channel 63a as an example, a pair of discontinuous walls 67a1 and 67a2 are provided. The walls are discontinuous as each wall must have a space for x-direction channels 65a-65g. For channel 65a running in the x direction, the pair of discontinuous walls are designated by reference numerals 69a1 and 69a2. These x-direction discontinuous walls have the same longitudinal configuration as y-direction walls 67a1 and 67a2, just that they provide spaces for channels 63a-p.

[0051] A discontinuous wall 71 as part of the tile sizing structure is also employed to form the slot 53 with the peripheral member 51 and allow the y-direction channels 63a-p to be open to the slots 53. Similar discontinuous walls are employed for each of the peripheral members 51 of the tile.

[0052] Turning back to the cutting slots and x-direction channel 65a, one cutting slot running in the x direction is designated by the reference numeral 73a. This cutting slot 73a is formed on one side by the discontinuous wall 69a1 that abuts or helps form the channel 65a with the other discontinuous wall 69a2. The other side of the cutting slot 73a is formed by wall segments of the discontinuous walls that form the y-direction channels

63a-63p and the other cutting slot wall is discussed in more detail below in connection with Figure 11. In the y direction, there would be 14 cutting slots 73a-73n. In the x direction, there would be 32 cutting slots, numbering 75a-75ff.

[0053] Figure 10 shows an enlarged sectional view of Figure 7 and one viewed along the lines X-X of Figure 9. When viewing along the line X-X, the discontinuous wall 67i2 of Figure 9 is shown in more detail. As noted above, the wall 67i2 is discontinuous for two reasons. One is that it must have one set of discontinuities or spaces for the channels, e.g., channel 65a, to be formed and run in the x direction. A second is the formation of another set of discontinuities in the wall 67i2 to allow the cutting slots, e.g., 73a, to also be formed and run in the x direction. In the embodiment of Figure 8 and shown in more detail in Figure 10, the discontinuities in the wall 67i2 for channel spaces are formed by the use of pins. With reference to x-direction channel 65a, a pairs of pins 79 are provided as part of the wall, opposing pairs of pins 79 are spaced apart in the y-direction, forming part of the x-direction channel 65a.

[0054] The wall 67i2 also includes number of wall segments 81, which function in part as forming the wall 67i2. The wall segments 81 combine with the pins 79 to create a discontinuous wall in the y direction, e.g., discontinuous wall 67i2, the discontinuous wall 67i2 forming the y direction channel 63i with an opposing discontinuous wall section not shown in Figure 9. Similar discontinuous wall sections, for example discontinuous wall sections 69a1 and 69a2 with its own set of wall segments 81, see Figure 8, run in the x direction to form the x direction channel 65a.

[0055] The pins 79 and wall segments 81 are arranged on an underside of the tile 50 in an alignment, wherein spaced apart opposing pins 79 are arranged to form part of the channel 65a for example. A wall segment 81 and a pin 79 adjacent thereto not only form part of the discontinuous wall 67i2, they also form part of a cutting slot running in the x direction, cutting slot 73a for example.

[0056] For the cutting slots, one of the pair of opposing discontinuous wall sections and faces of the wall segments 81 form the cutting slots. With reference to Figure 11, a view along the line Xi-XI of Figure 8, shows cutting slot 75w. It can be seen that one wall of the cutting slot is formed by faces 81a of the wall segments 81 form a discontinuous wall 85w. This discontinuous wall 85w coupled with discontinuous wall section 6711, see Figure 9, forms the cutting slot 75w. The discontinuous wall section 6711 and faces 81a of the wall segments 81 function as a guide for cutting of the tile along the cutting slot 75w.

[0057] For the slot 53, aligned wall segments 81 and aligned faces 81a of other wall segments 81 face the outer peripheral member 51 to form the slots 53.

[0058] Referring back to Figure 9, each corner of the tile underside structure has an l-shaped wall segment 84 made up of two wall segments joined together. There is

no need to have disconnected wall segments at the corners of the underside tile structure as the cutting slots are spaced from each slot 53 that follows the periphery of the tile.

[0059] The y direction channels 63a-p and x direction channels 65a-65g are designed with two functions in mind. In one function, the channels accommodate one or more support boards 90, which is shown in Figure 12. The support board 90 is designed to press fit within one or more of the channels 63a-p and 65a-g in the tile 50 and rest on one of the supporting surfaces 39 of the beam shown in Figure 4B. The support board 90 provides support for the tile when it is sized is changed by removing parts of the tile using the cutting slots. Another function of the channels 63a-9 and 65a-g has the channels replicating the function of the outer peripheral member 51 and the slot 53 as described in more detail below.

[0060] Figure 13 shows an uncut tile 50 in combination a pair of support boards 90. The support boards 90 are positioned in x-direction channels 65a and 65g. The tile is then cut along cutting slots 73a and 73n so that the tile would be reduced in with y direction while maintaining the same length in the x direction. The tile could then be used in a platform system with the y direction slots 53 engaging a pair of spaced apart beams. As noted above, the support boards 90 are sized so that a face 93 of each end portion 91 would rest on the supporting surfaces 39 of the beam 3, see Figures 4A and 4B. In this mode of use, the parts of the tile in terms of the outer peripheral member 51 and slot 53 are used in support of the tile with the beams 3. While Figure 12 shows the tile dimension adjusted in the y direction, the support boards 90 could be arranged in the two of the channels 63a-63p and the tile dimension could be adjusted in the x direction as well. In this mode, the other set of original outer peripheral members 51 and slots 53 extending in the x-direction would be used to secure the tile to a pair of beams 3.

[0061] Figure 14 shows another schematic similar to that use in Figure 9 as an example of the tile being reduced in both x and y directions. In this drawing, the tile is reduced in dimension in both the x and y directions. The tile would be cut at y-direction cutting slot 75o and x-direction cutting slot 73j. With this cut configuration, a support board 90 could be inserted into channel 65e. The tile could be placed between two beams, one beam engaging the channel 63h and the other beam engaging the y-direction slot 53. In this configuration, the tile is supported across its longer dimension. However, if the platform system was such that the tile needed to be supported across its shorter dimension, a support board could be placed in channel 63h and the x-direction slot 53 and the channel 65e could be used to engage beams of the platform system.

[0062] By having a large number of channels and cutting slots, the tile dimension can be fine tuned in small dimensions. While the spacing of the wall segments and pins can vary for the number of cutting slots in both the x and y directions, the wall segments and pins can be

arranged so that the tile can be cut in 1 inch increments for a precise control of the customized tile shape. Referring back to Figure 9, the y-direction cutting slot 75a can be spaced an inch from the y-direction cutting slot 75c. Instead of making the y-direction cut in cutting slot 75a and using a support board in y-direction channel 63a, one could reduce the x-direction length of the tile by one inch and cut along cutting slot 75c and use a support board in y-direction channel 63b.

[0063] The customizable tile can be provided separately to users of an existing modular platform system or included as part of the modular platform system along with stock size tiles. Then, the modular platform system could be made with a combination of stock size tiles and customizable tiles for the ultimate in control in the size of the platform system.

[0064] While the discontinuous walls are made up of pins and wall segments to create the intersecting channels and intersecting cutting slots, other configurations for the portions of the walls that create the channels and cutting slots could be used. For example, while generally cylindrical pins are shown, the pins could be polygonal in shape, e.g., have a square transverse cross section. Likewise, instead of faces of wall segments forming one of the walls that form the cutting slots, other structure could be added between the faces of the wall segments (or substituted for the faces of the wall segments) to increase the area of the wall facing the discontinuous wall that forms one side of the channel.

[0065] When creating a modular platform using tiles, beam, and legs, the customizable tiles can be incorporated into the method of creating the modular platform. Once the size of the tile is known for use in the platform, the tile can be cut to size using one or more of the cutting slots and one of more of the channels for support board engagement.

[0066] While the customizable tile can be made out of any material, a preferred material would be a non-metallic material, e.g., a polymer like polypropylene, polyethylene, polyvinyl chloride, and the like and engineered plastics like ABS and the like. Having a non-metallic material like a polymer makes it much easier to cut the tile to a desired size using the cutting slots as opposed to the aluminum tiles that were used in prior art systems.

[0067] The support boards are also preferably made from a non-metallic material as well as the support boards may need to be cut to size. For example, in Figure 13, the boards extend along the entire x-direction of the tile so that cutting to narrow the width of the tile would not require cutting the support boards. However, the tile that is adjusted in width and length as shown in Figure 14 would require cutting of the support board. While the support boards could be a metallic material, they could also be made from a polymeric material, like that exemplified for the tile itself.

[0068] It should also be understood that if the tile is cut to a size that is quite small as compared to the original size of the tile for use in a modular platform system, the

tile itself when attached to beams of the modular platform system may be able to support any loads placed on the tile during platform use. In these instances, one or more support boards would not be required.

[0069] As noted above, the customizable tile provides a significant advantage when construction platform systems like the one shown in Figure 1. With the customizable tile, very fine size adjustments, e.g., on the order of an inch can be achieved so that the platform can be easily sized for any designed configuration. Since the tiles are made of a polymer material, e.g., high density polyethylene, polypropylene, or other high strength polymers, they can be cut on site once the platform system is being constructed. They are also more easily cut than the prior art tiles, which were made of aluminum. With these tiles, it was typical to have to receive the dimensions of the platform system prior to delivery of the system and have the tiles cut prior to delivery. This pre-cutting did not provide any leeway if the dimensions of the platform system needed to be altered. With the customizable tiles, any dimensional changes could be easily accommodated on site when the platform system is being constructed.

[0070] The cutting of the tile along the cutting slots can be done using any known cutting tool, saws, slitting blades, etc.

[0071] Since the tiles are not only customizable in size, the presence of the channels and capability to use a support board also the use of non-metallic materials as the support board can provided the needed strength to support a load on the tile when the tile is spanning beams in the platform system.

[0072] As such, an invention has been disclosed in terms of preferred embodiments thereof which fulfills each and every one of the objects of the present invention as set forth above and provides a new and improved customizable tile for use in a modular platform system, a modular platform system including one or more of the customizable tile, and a method of creating the modular platform system.

[0073] Of course, various changes, modifications, and alterations from the teachings of the present invention may be contemplated by those skilled in the art without departing from the intended spirit and scope thereof. It is intended that the present invention only be limited by the terms of the appended claims.

Claims

1. A customizable sized tile comprising:

a top portion and a tile periphery, the tile periphery including peripheral members,
a tile size adjusting structure extending from an underside of the top portion, a periphery of tile size adjusting structure and the peripheral members forming a peripheral slot inward of the

peripheral members;

the tile size adjusting structure further comprising a plurality of channels extending in first and second directions, and a plurality of cutting slots also extending in the first and second directions, the channels and cutting slots extending in the first direction intersecting with the channels and cutting slots extending in the second direction; for channels and cutting slots extending in the same direction, each channel is positioned between a pair of cutting slots, cutting along one or more of the cutting slots allowing the dimension of the tile to be reduced.

5

10

15

20

25

30

35

40

45

50

55

2. The tile of claim 1, wherein the tile is made of a polymeric material.

3. The tile of claim 1, wherein each channel is formed by opposing discontinuous walls, each discontinuous wall having spaces to accommodate intersecting channels and intersecting cutting slots.

4. The tile of claim 3, wherein each cutting slot is formed by one of the opposing discontinuous walls for each channel and a second discontinuous wall, the second discontinuous wall formed by wall segments of the opposing discontinuous walls forming channels intersecting the cutting slot.

5. The tile of claim 1, wherein corners of the periphery of the tile size adjusting structure includes L-shaped wall segments.

6. The tile of claim 1, wherein the top portion has a plurality of openings therethrough.

7. The tile of claim 1, wherein the top portion has a closed top surface with no openings therethrough.

8. The tile of claim 6, wherein surface portions of the top portion include protrusions for traction.

9. The tile of claim 7, wherein the closed top surface has raised or recessed portions to provide traction.

10. A tile assembly comprising the customizable tile of claim 1 and at least one support board, the at least one support board sized to fit into one of the channels.

11. The assembly of claim 10, wherein the at least one support board is cuttable so that the at least one support board that can fit into a channel whose length is changed by cutting of the tile along one of the cutting slots thereof.

12. In a modular platform system comprising tiles, beams, and legs, wherein the tiles are supported

by the beams and the beams are supported by the legs, the improvement comprising at least one of the customizable tiles of claim 1.

13. The modular platform system of claim 12, further comprising and at least one support board, the at least one support board sized to fit into one of the channels. 5

14. In a method of creating a modular platform system at an on-site location, wherein tiles are attached to beams at the on-site location site and the beams are attached to legs at the on-site location, the improvement comprising providing at least one of the customizable tiles of claim 1, and cutting the at least customizable tile at the on-site location for fitting on at least two beams. 10 15

15. The method of claim 10, wherein at least one support board is provided, the support board sized to fit into one of the channels, and the at least one support board is positioned in one of the channels after the tile is cut. 20

16. The method of claim 11, wherein the at least one support board is also cut to a predetermined size before being positioned in the channel of the cut customizable tile. 25

30

35

40

45

50

55

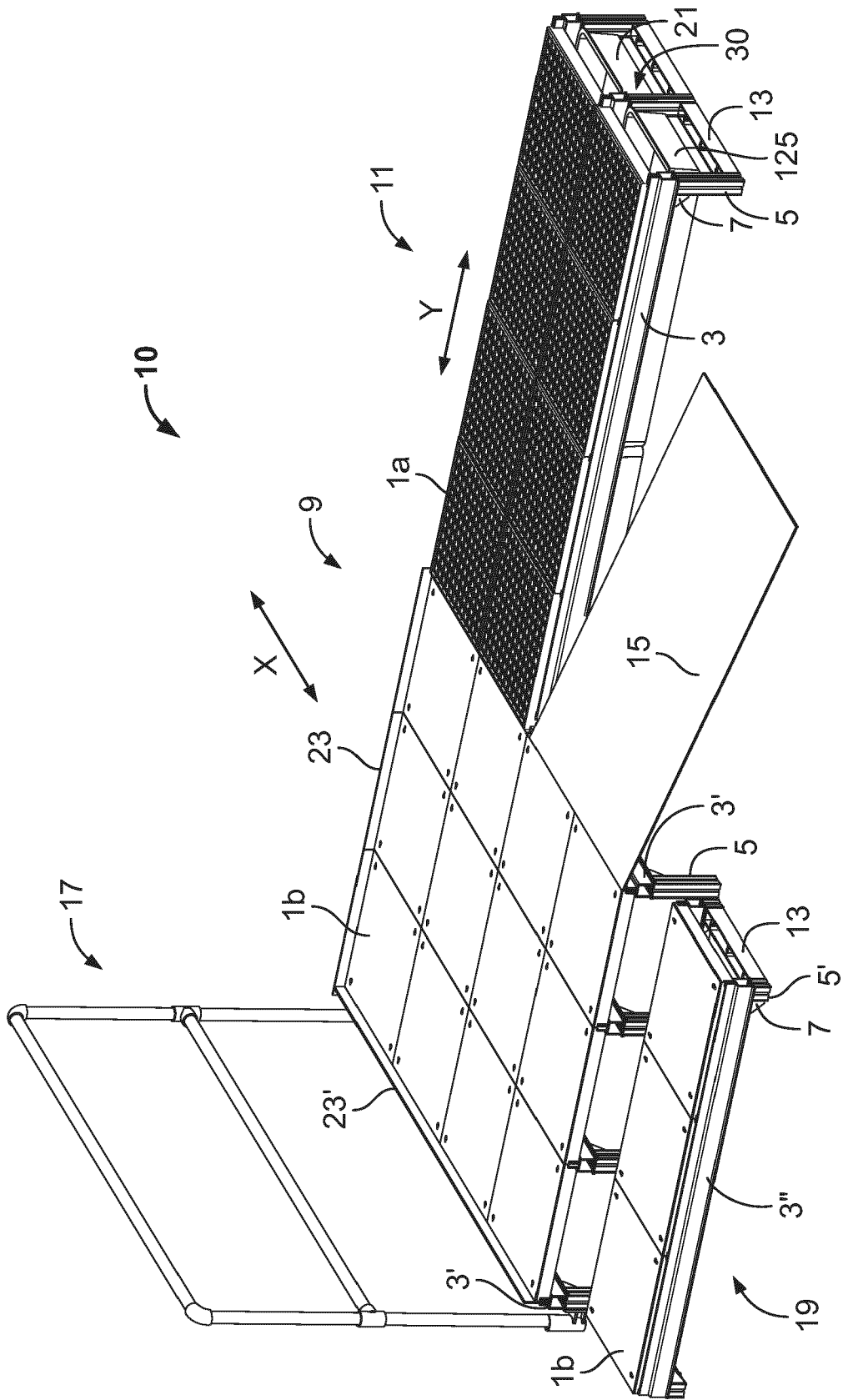

FIG. 1

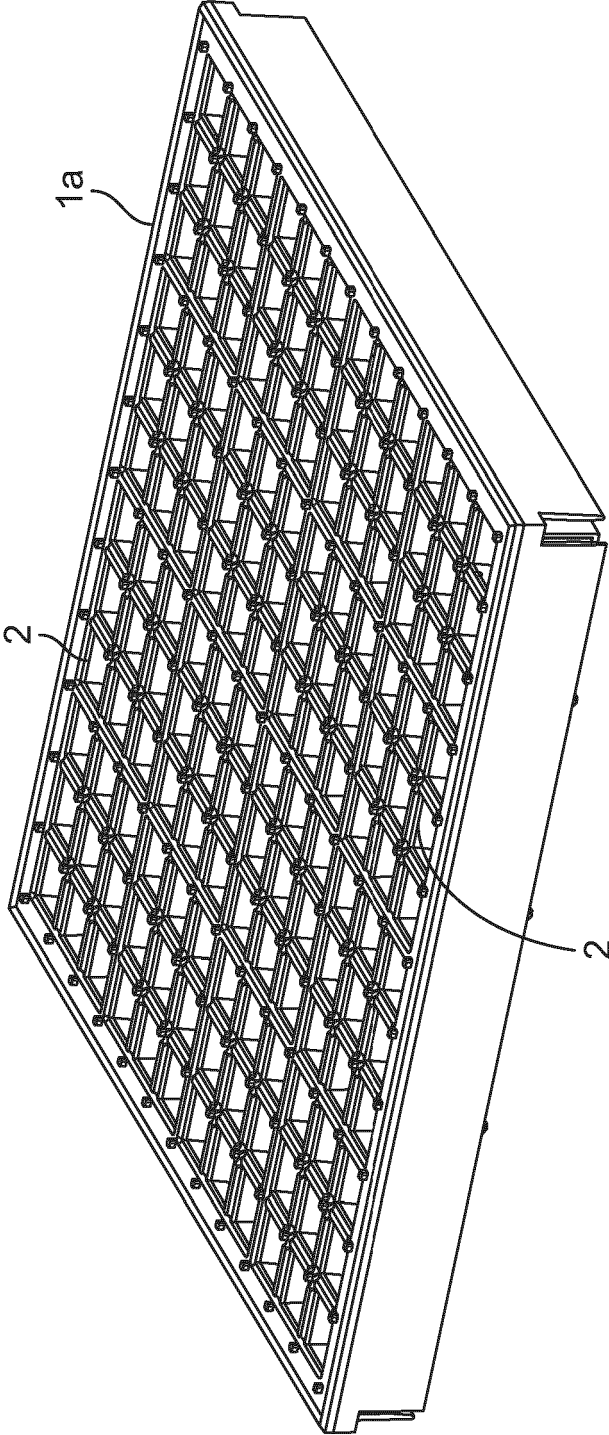

FIG. 2

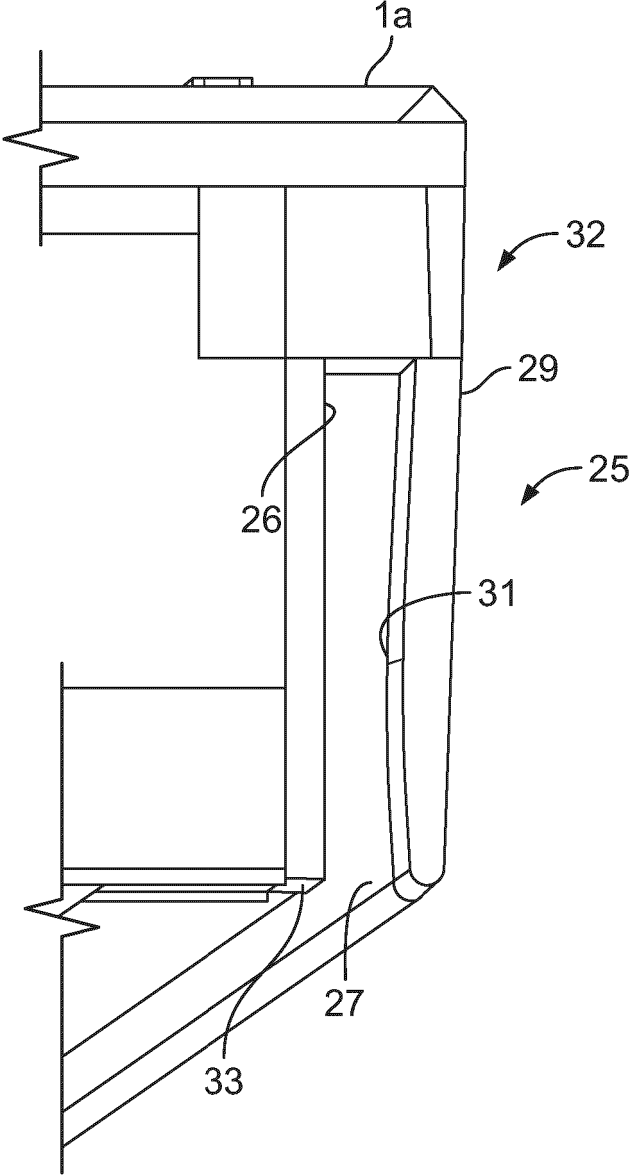

FIG. 3

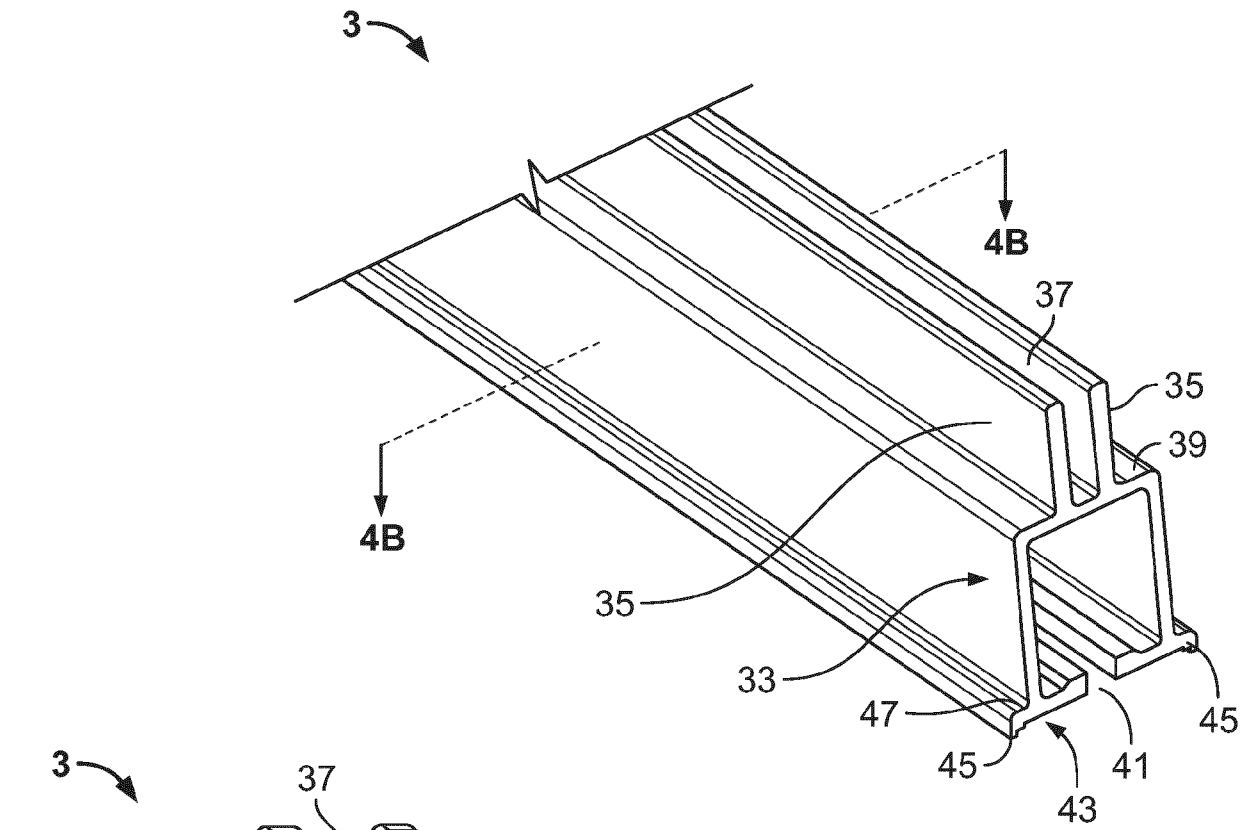

FIG. 4A

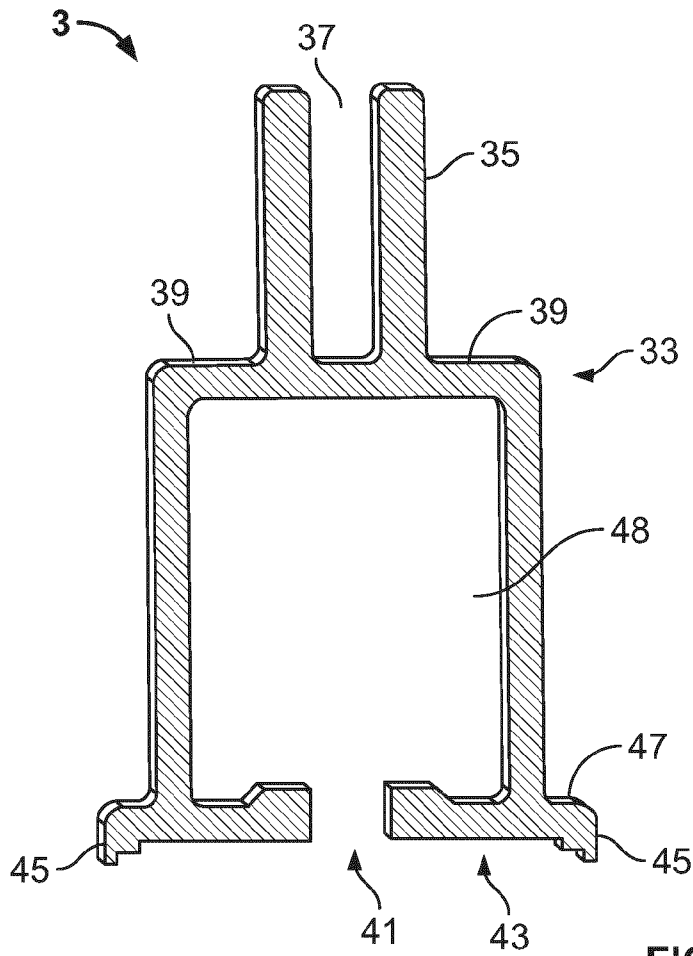

FIG. 4B

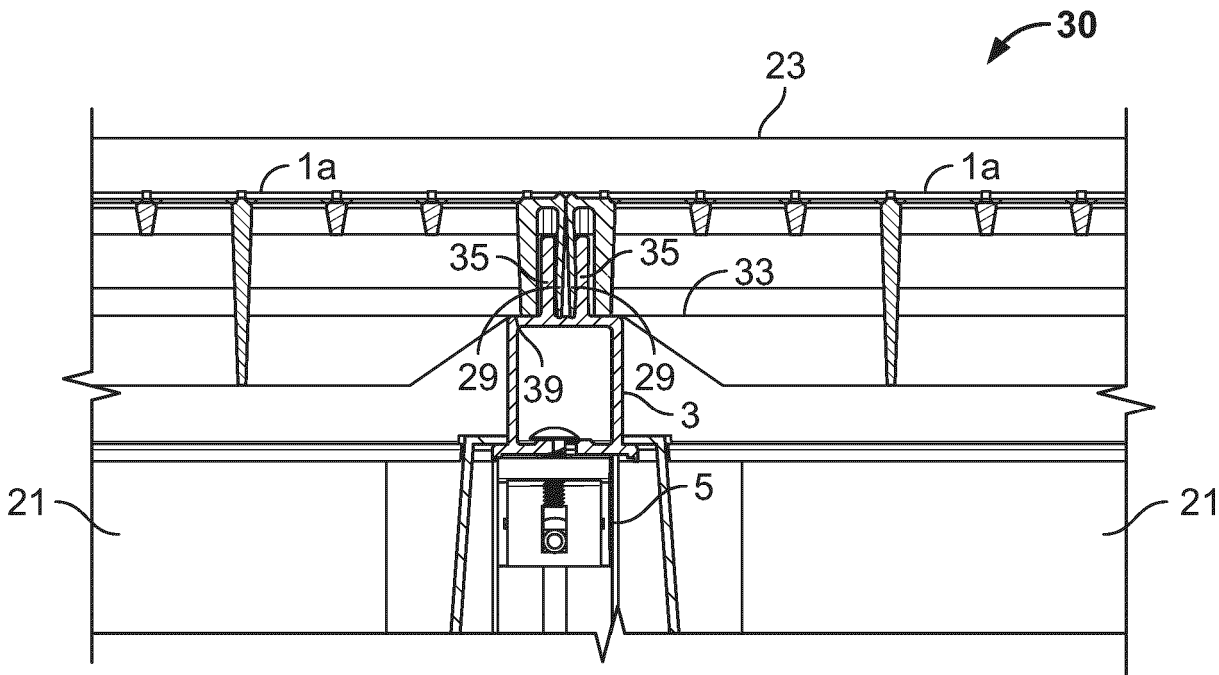

FIG. 5

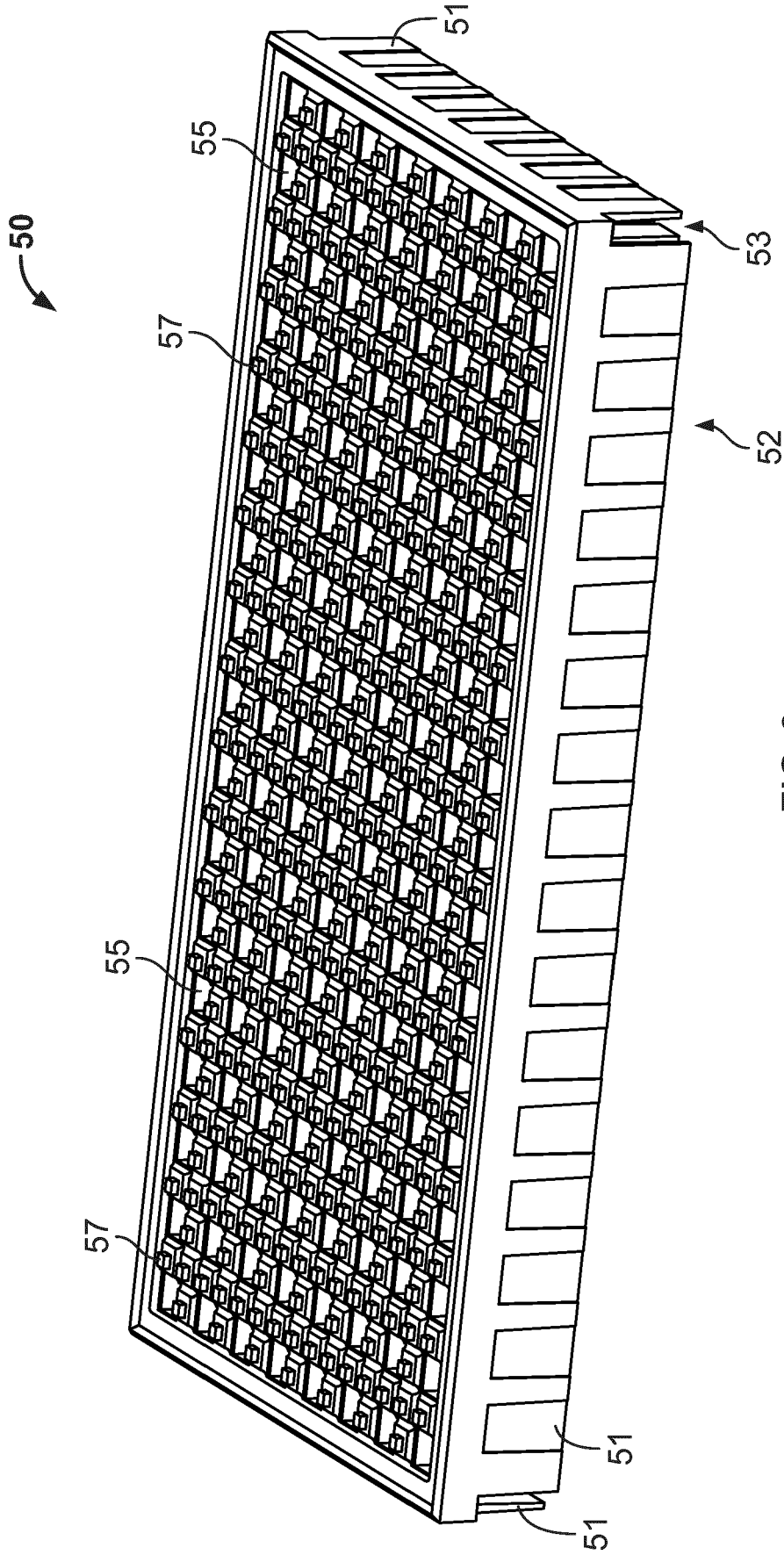

FIG. 6

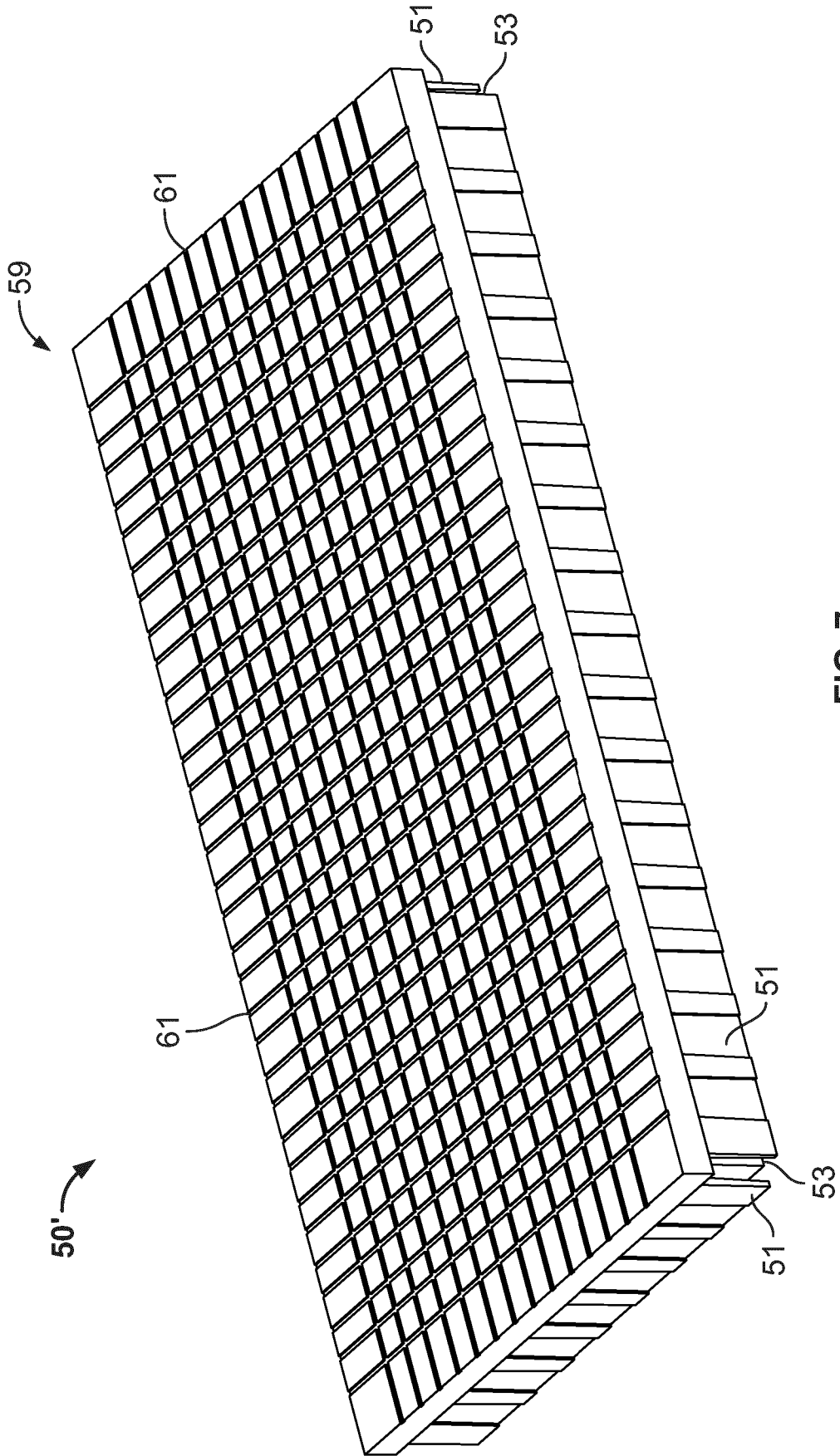

FIG. 7

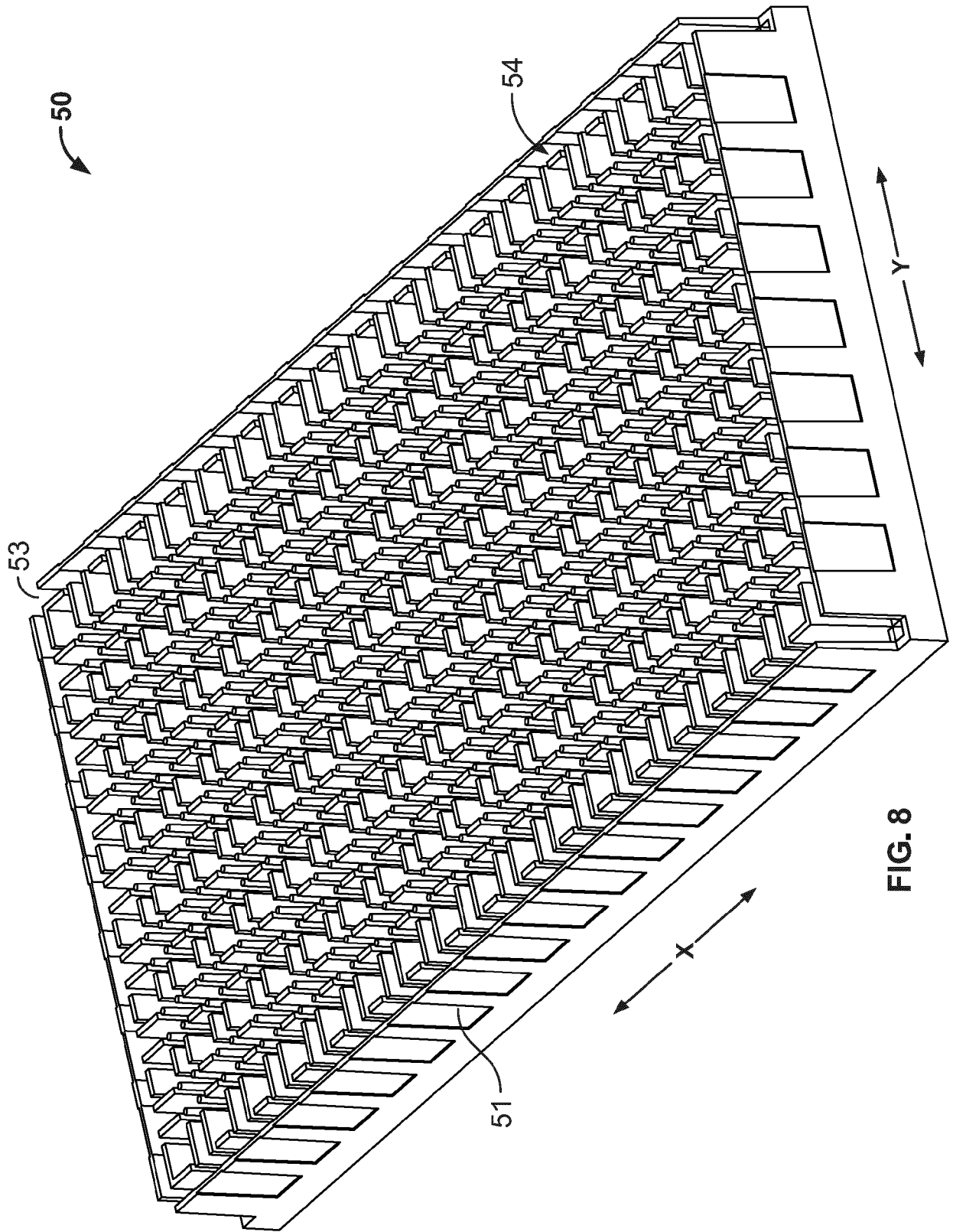

FIG. 8

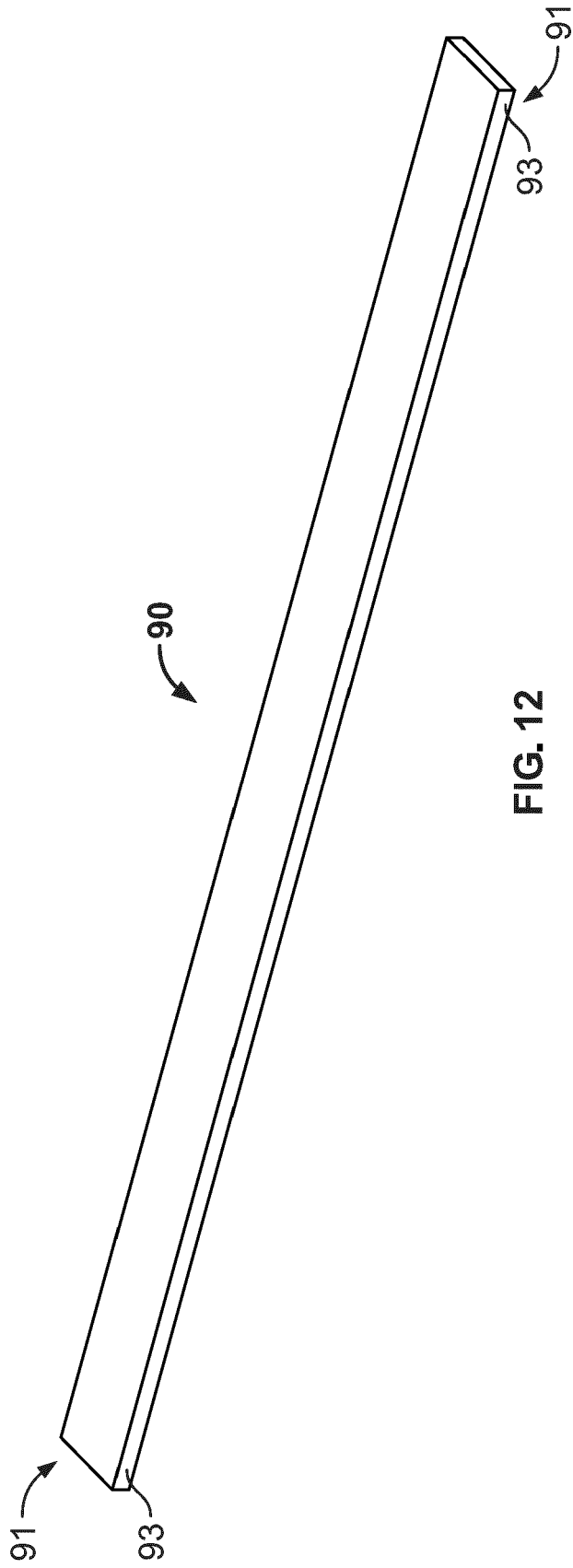

FIG. 12

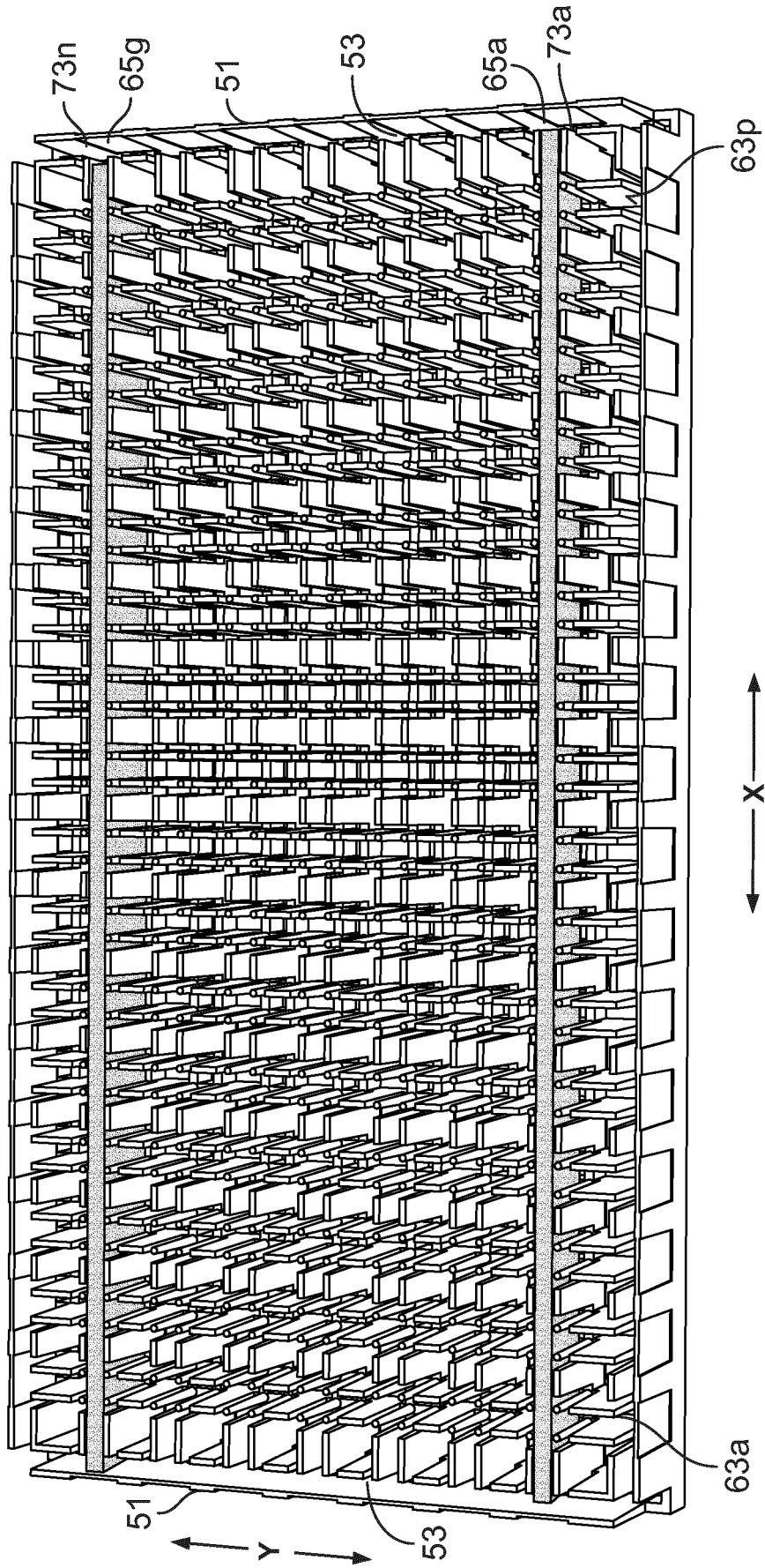

FIG. 13

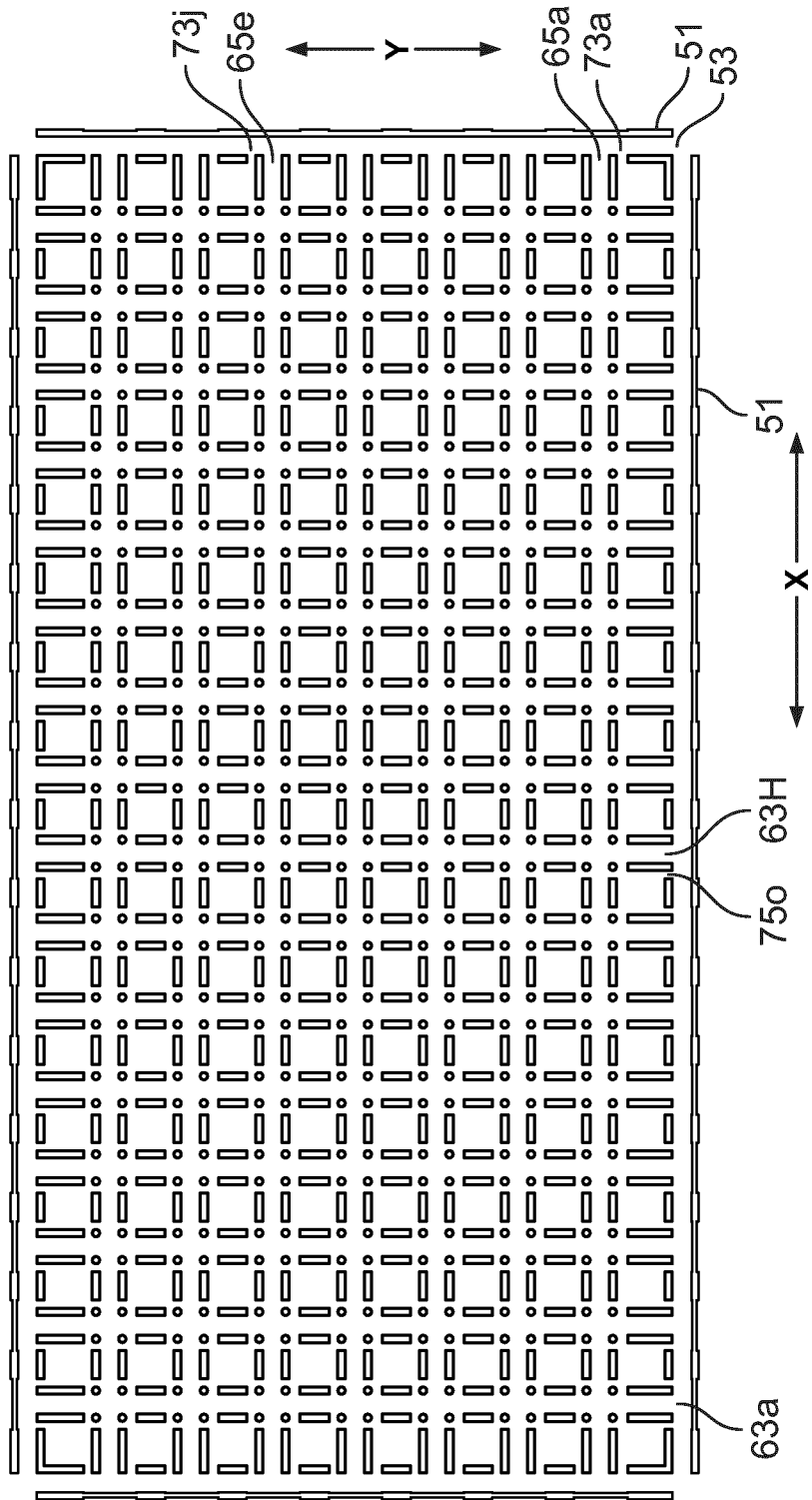

FIG. 14



EUROPEAN SEARCH REPORT

Application Number
EP 24 18 8337

5

10

15

20

25

30

35

40

45

50

55

DOCUMENTS CONSIDERED TO BE RELEVANT			
Category	Citation of document with indication, where appropriate, of relevant passages	Relevant to claim	CLASSIFICATION OF THE APPLICATION (IPC)
Y	US 2005/252109 A1 (FUCCELLA DANIEL C [US] ET AL) 17 November 2005 (2005-11-17)	1, 2, 5-9, 12, 14	INV. E04F15/02
A	* figures 1-2, 13-16 * * paragraph [0019] * * paragraph [0048] - paragraph [0052] * -----	3, 4, 10, 11	E04F15/024 E04F15/10
Y	US 2022/064965 A1 (HUSS PHILIP C [US] ET AL) 3 March 2022 (2022-03-03)	1, 2, 5-9, 12, 14	
A	* figures 1, 2A, 3A-3C, 4A-4B, 5 * * paragraph [0074] * -----	13, 15, 16	
			TECHNICAL FIELDS SEARCHED (IPC)
			E04F
The present search report has been drawn up for all claims			
Place of search Munich		Date of completion of the search 3 December 2024	Examiner Estorgues, Marlène
CATEGORY OF CITED DOCUMENTS X : particularly relevant if taken alone Y : particularly relevant if combined with another document of the same category A : technological background O : non-written disclosure P : intermediate document		T : theory or principle underlying the invention E : earlier patent document, but published on, or after the filing date D : document cited in the application L : document cited for other reasons & : member of the same patent family, corresponding document	

1
EPO FORM 1503 03.82 (P04C01)

**ANNEX TO THE EUROPEAN SEARCH REPORT
ON EUROPEAN PATENT APPLICATION NO.**

EP 24 18 8337

5 This annex lists the patent family members relating to the patent documents cited in the above-mentioned European search report.
The members are as contained in the European Patent Office EDP file on
The European Patent Office is in no way liable for these particulars which are merely given for the purpose of information.

03 - 12 - 2024

Patent document cited in search report	Publication date	Patent family member(s)	Publication date
US 2005252109 A1	17 - 11 - 2005	CA 2556881 A1	09 - 09 - 2005
		GB 2427211 A	20 - 12 - 2006
		US 2005252109 A1	17 - 11 - 2005
		WO 2005081923 A2	09 - 09 - 2005

US 2022064965 A1	03 - 03 - 2022	CA 3128792 A1	03 - 03 - 2022
		EP 3964671 A1	09 - 03 - 2022
		ES 2947785 T3	18 - 08 - 2023
		PL 3964671 T3	02 - 10 - 2023
		US 2022064965 A1	03 - 03 - 2022
		US 2022356718 A1	10 - 11 - 2022

EPO FORM P0459

For more details about this annex : see Official Journal of the European Patent Office, No. 12/82

REFERENCES CITED IN THE DESCRIPTION

This list of references cited by the applicant is for the reader's convenience only. It does not form part of the European patent document. Even though great care has been taken in compiling the references, errors or omissions cannot be excluded and the EPO disclaims all liability in this regard.

Patent documents cited in the description

- WO 4676036 A, Bessert **[0002]**
- WO 6256952 A, Fahy **[0002]**
- WO 4901490 A, Zinniel **[0002]**
- WO 4561232 A, Gladden, Sr. **[0002]**
- WO 7360343 A, Spransy **[0002]**
- WO 2956653 A **[0002]**
- WO 3180460 A, Liskey Jr. **[0002]**
- WO 20220356718 A, Huss **[0003]**