



(51) International Patent Classification:
F24J 2/04 (2006.01) F24J 2/54 (2006.01)
F24J 2/40 (2006.01)

(21) International Application Number:
PCT/IT2008/000525

(22) International Filing Date:
31 July 2008 (31.07.2008)

(25) Filing Language: English

(26) Publication Language: English

(71) Applicants (for all designated States except US): **INTERNEW ELECTRONICS S.R.L.** [IT/IT]; Contrada Piancardillo, 37, I-85010 Pignola, Potenza (IT). **GOEDSK.IT DI PASCUALE DE MARTINO** [IT/IT]; Contrada Piancardillo, 37, I-85010 Pignola Potenza (IT).

(72) Inventor; and
(75) Inventor/Applicant (for US only): **DE MARTINO, Pasquale** [IT/IT]; Contrada Pignola, 37, I-85010 Pignola, Potenza (IT).

(81) Designated States (unless otherwise indicated, for every kind of national protection available): AE, AG, AL, AM, AO, AT, AU, AZ, BA, BB, BG, BH, BR, BW, BY, BZ, CA, CH, CN, CO, CR, CU, CZ, DE, DK, DM, DO, DZ, EC, EE, EG, ES, FI, GB, GD, GE, GH, GM, GT, HN, HR, HU, ID, IL, IN, IS, JP, KE, KG, KM, KN, KP, KR, KZ, LA, LC, LK, LR, LS, LT, LU, LY, MA, MD, ME, MG, MK, MN, MW, MX, MY, MZ, NA, NG, NI, NO, NZ, OM, PG, PH, PL, PT, RO, RS, RU, SC, SD, SE, SG, SK, SL, SM, ST, SV, SY, TJ, TM, TN, TR, TT, TZ, UA, UG, US, UZ, VC, VN, ZA, ZM, ZW.

(84) Designated States (unless otherwise indicated, for every kind of regional protection available): ARIPO (BW, GH, GM, KE, LS, MW, MZ, NA, SD, SL, SZ, TZ, UG, ZM,

[Continued on next page]

(54) Title: MODULAR SOLAR PANEL WITH ROTATING COLLECTORS FOR WINDOWS AND FACADES

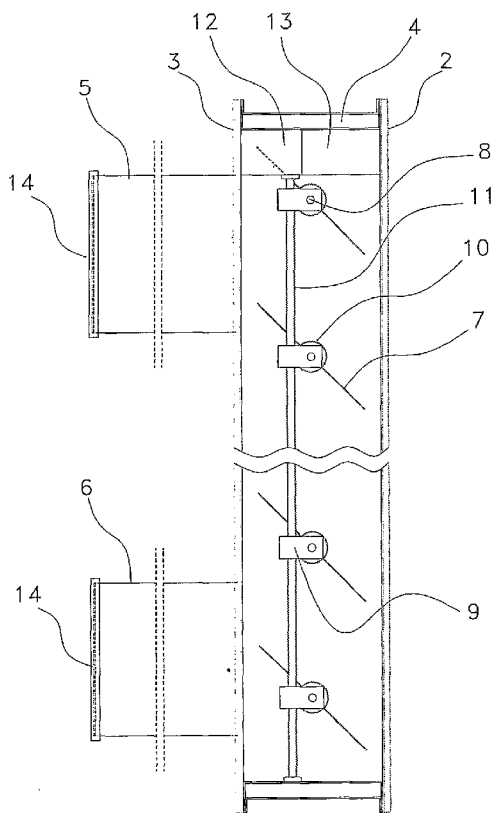

fig. 7a

(57) Abstract: Thermal solar panel for windows and continuous facades having a front (2) surface and a back surface (3) constituted by a transparent glass. The back surface (3) comprises an outtake /intake warm air hole (5) and an intake /outtake cold air hole (6), Internally to the panel (1) revolving collectors (7) are installed, each of them respectively with one side of very dark colour and the other one of very clear colour.

WO 2010/013269 A1

ZW), Eurasian (AM, AZ, BY, KG, KZ, MD, RU, TJ, TM), European (AT, BE, BG, CH, CY, CZ, DE, DK, EE, ES, FI, FR, GB, GR, HR, HU, IE, IS, IT, LT, LU, LV, MC, MT, NL, NO, PL, PT, RO, SE, SI, SK, TR), OAPI (BF, BJ, CF, CG, CI, CM, GA, GN, GQ, GW, ML, MR, NE, SN, TD, TG).

Published:

— *with international search report (Art. 21(3))*

Description

Modular solar panel with rotating collectors for windows and facades

Technical field

5 Solar panel, transparent on the front and back sides, internally furnished with thermal revolving collectors for the production of thermal energy, to be installed in place of the normal glass windows, using their regular chassis, or as a continuous facade on industrial sheds and houses.

Technique state

10 The sun is an inexhaustible resource for man. The use of technologies which exploit this resource can give a big contribution to the solution of problems tied to the thermal pollution, with an abrupt decrement of CO₂ emissions in the air. The whole world is actually focusing to develop technologies and products which use the solar energy both to heat,
15 eventually at high temperatures, liquids or gases, and to directly produce electrical energy.

The most known are thermal sun panels, essentially composed of a box with an upper transparent surface and a lower opaque one; inside there is a serpentine or a dark catching plate in which a fluid, generally water,
20 flows. These panels are assembled on the roofs of houses and industrial sheds or on platforms for the purpose of heating the fluid with the solar radiation.

To avoid they can be shuttered because of a storm or a strong wind, they are fixed on the site, with a optimal inclination which depends on the latitude of the place, usually 45-60° faced south, to take advantage from the solar radiation. It would be better the solar panel could follow the sun by varying its inclination above the horizon to collect optimally the solar radiation.

The motorization of these panels is not convenient, because they are heavy and as stated they must be well fixed; a system of inclination of the whole panel would involve higher costs not justified by the energetic return.

Purposes and advantages of the invention

The purpose of this invention is to make a solar panel using air as fluid, and having only an active movable collecting part, simply said the collectors, in order to optimize solar radiance.

Other purpose of this invention in agreement with the previous one where the movement of the active movable collecting part can be obtained manually or with an automated software controlled device, by means of a solar clock.

Other purpose of this invention in agreement with the previous one where the active collecting part, i.e. the collectors, are made of high thermal conductivity material, and the two sides of the collectors are respectively one of very dark colour and the other one of very clear colour.

Other purpose of this invention in agreement with the previous ones is to make a thermal solar panel with revolving collectors having the

characteristic to be transparent on the main - front and back - sides, in order to be installed as a normal glass window inside a chassis, or as a continuous front facade.

Other purpose of this invention in agreement with the previous ones is that the internal collectors can rotate along their elongation axis of symmetry, by 360° allowing to be used, in the case of window like installation, also as darkening or shady curtain as protection from excessive light, a typical condition when the sun is below 45° of the horizon.

Other purpose of this invention in agreement with the previous ones is that the thermal solar panels with revolving collectors for windows and continuous facades have the possibility to be embedded each other to synchronize the movement of the collectors in order that an eventual ribbon window or continuous facade can have a single colour at the observer's view, contributing to a less intrusive architectural impact; the collectors in such a position don't take away excessively from the chromatic effect given from the colour or the aesthetic of the building.

Description of the Drawings and way to carry out the invention

These and other characteristics as well as advantages will result evident from the following description and from the enclosed drawings showed for just indicative purpose and not limitative in which:

Figure 1 shows a front view of the thermal panel with revolving collectors.

Figure 2 shows an orthogonal lateral view of the thermal panel with revolving collectors.

Figure 3 shows an orthogonal view from top of the thermal panel with revolving collectors.

Figure 4 shows a lateral section view of the thermal panel with revolving collectors.

5 Figure 5 shows another section view from top of the thermal panel with revolving collectors.

Figures 6a and 6b show respectively front side and top of the typical set with the motorized panel.

10 Figures 7a and 7b show details of the connection mechanism of the revolving collectors.

Figures 8a and 8b show details of the embedding mechanism of the thermal panel with revolving collectors.

Figure 9 shows the end- closure of the thermal panel with revolving collectors.

15 Figure 10 shows a front view of the panel with revolving collectors with photovoltaic panel.

Figure 11a and 11b show details of the panel with revolving collectors with manual mechanism.

20 Figure 12 shows an example of application of the panel in place of the regular window glass of a house.

Figure 13 shows an example of application of the panel by simulating the shutters of a house.

Figure 14 shows an example of application of the panel as continuous facade of a house.

Figure 15 shows an example of application of the panel alternated with the windows of a house.

5 In accord to the enclosed drawings, (1) indicates the panel object of this invention, (2) the front surface made of a transparent glass, (3) the back surface made of a transparent glass, (4) the perimetral structure made of a metal section; the outtake/intake warm air hole (5) is placed in the middle of the upper part of the back side (3), the intake/outtake cold air hole (6) is
10 in the middle of the lower part of the back side (3), so to perform warm and cold air exchange in the room; both holes have an anti-dust filter (14).

Within the panel (1) collectors (7) are placed that are made of a high heat conductivity plane plate with the surface of the two sides of the plate, front and back, that are respectively one of very dark color and the other of very
15 clear color.

Alternatively the collectors (7) plane plate can have holes (22) throughout it to favor air flow or the collectors (7) can be realized with an honeycomb structure to increase the heat exchange surface.

Collectors, with the help of an electrical engine (12) and a battery (13)
20 rechargeable with a solar panel (23) can be oriented by rotation; the rotation movement along the elongation axis (8) allows to optimize the collector surface position to better absorb the solar radiation. The rotation movement along the elongation axis (8) of each collector (7) occurs

through a tie point made of a support (9) for axis (8) and a gear (10) connected to an endless screw (11) moved by the engine (12).

The panel will be preferably placed along a south-exposed wall, with the collectors dark surface exposed to sun rays so to fully exploit solar radiation, heating the air that flows near or through the collectors.

The alternate exposure of the clear and dark collectors side and their inclination angle, allow to modulate the heat intake of the building.

Through a manual control or an automatic solar clock control, the collectors (7) can rotate by 360° allowing to be used, in the case of window like installation , also as darkening or shady curtain as protection from excessive light, a typical condition when the sun is below 45° of the horizon.

Panel (1) can be used to produce also cold air. When installed to the Northern side of a building, with the clear surface of the collectors exposed, it acts as a heat barrier and favors the outflow of warm air from inside the building, facilitating the inflow of cooler air inside.

Panel (1), due to its air exchange capacity contributes to human beings health, favoring the establishment of an optimal environment counteracting mildews and bacteria formation, characteristics of humid and badly ventilated spaces.

Panel (1) installed on a wall helps to reduce visual impact, since the collectors placed with respect to the viewer position in such a way that they do not interfere excessively with the chromatic effect or the aesthetic of the building itself, when the panels (1) are mounted as a continuous

facade, by means of expanded polyurethane spacers (15), of appropriate
fixing system made of a cylinder with a hole (16) and relative hexagonal
holed head screw (17), of seal (18), and of closure end plug (19), can be
embedded each other to synchronize the collectors movement through
5 one or few motorized panels (depending on the wall dimensions and
taking into account the fact that one motorized panel can move up to three
other ones without engine) in such a way that the wall can achieve a
uniform color.

Serially mounted panels as a continuous façade help in reducing building
10 heat loss, because of the panel internal air chamber, becoming an
alternative insulation solution that counteract thermal dissipation and
contributes to energy saving.

In a different construction approach of the present invention, the laminar
collector can be manually rotated, in particular when they are installed on
15 a window in place of a glass window. In this case a pulley (29) allows to
wrap/unwrap a rope (21) that moves the endless screw bar connected to
the gear (10)

Claims

- 1) Solar thermal panel for windows and continuous facades characterized by the fact of having: the front side (2) and the back side (3) transparent, the outtake/intake warm air hole (5) placed in the middle of the upper part of the back side (3), the intake/outtake cold air hole (6) in the middle of the lower part of the back side (3) both with anti-dust filter (14); high heat conductivity micropierced (22) thin plate shaped rotating collectors (7) with one very dark and one very clear side are mounted in the panel interior.
- 2) Solar thermal panel for windows and continuous facades as of claim 1) characterized by the fact that the rotational movement along the elongation axis (8) of each collector (7) occurs through a tie point constituted by a support (9) for axle (8) and by a gear (10) coupled to an endless screw bar (11) rotated by an electrical engine (12) with rechargeable battery with photovoltaic panel (23).
- 3) Solar thermal panel for windows and continuous facades as of claim 1) and 2) characterized by the fact that the collectors (7) can rotate by 360° through a manual or an automated solar clock control allowing to be used, in the case of window like installation, also as darkening or shady curtain as protection from excessive light, a typical condition when the sun is below 45° of the horizon.
- 4) Solar thermal panel for windows and continuous facades as of claim 1), 2), and 3) characterized by the fact that the panel is mounted on a South exposed wall with the dark surface of the collectors exposed to

sun, so to heat the air that flows through the collectors or is mounted on a North exposed wall with the clear surface of the collectors positioned toward the external side so to counteract the heat e to favor the outflow of warm air from the building and to the inflow of cooler air inside it..

5) Solar thermal panel for windows and continuous facades as of claim 1), 2), 3), and 4) characterized by the fact that panels can be joined by embedding each other by means of expanded polyurethane spacers (15), of appropriate fixing system made of a cylinder with a hole (16) and relative hexagonal holed head screw (17), of seal (18), and of closure end plug (19), to synchronize the collectors movement in such a way that they do not detract excessively from the chromatic effect given by the color or from the esthetic of the building, contributing to a minor architectural impact.

6) Solar thermal panel for windows and continuous facades as of claim 1) and 5) characterized by the fact that a single motorized panel can rotate the collectors (7) of at least three other panels without engine.

7) Solar thermal panel for windows and continuous facades as of claim 1) characterized by the fact that the plane surface of the collectors (7) can have holes (22) to favor air flow within the panel or the collectors (7) can have honeycomb structure to increase thermal exchange through a larger surface.

8) Solar thermal panel for windows and continuous facades as of claim 1) characterized by the fact that the laminar collectors can be manually

rotated, through a pulley (20) that wrap/unwrap a rope (21) that moves the endless screw bar (11) connected to a gear (10).

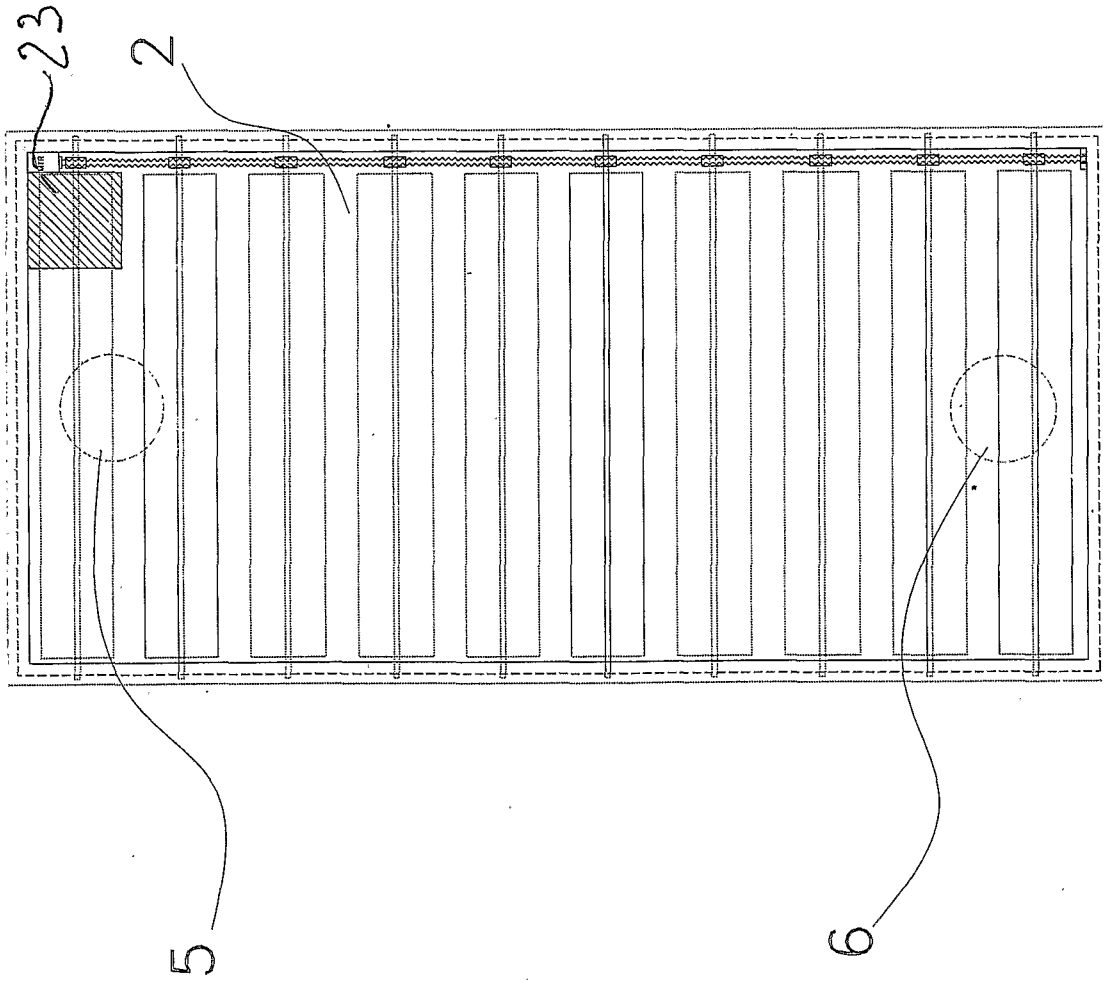

fig. 1

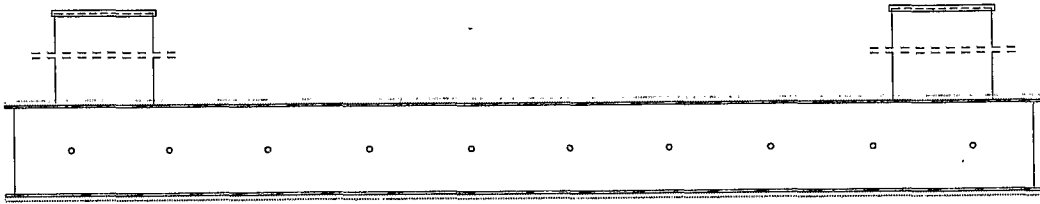
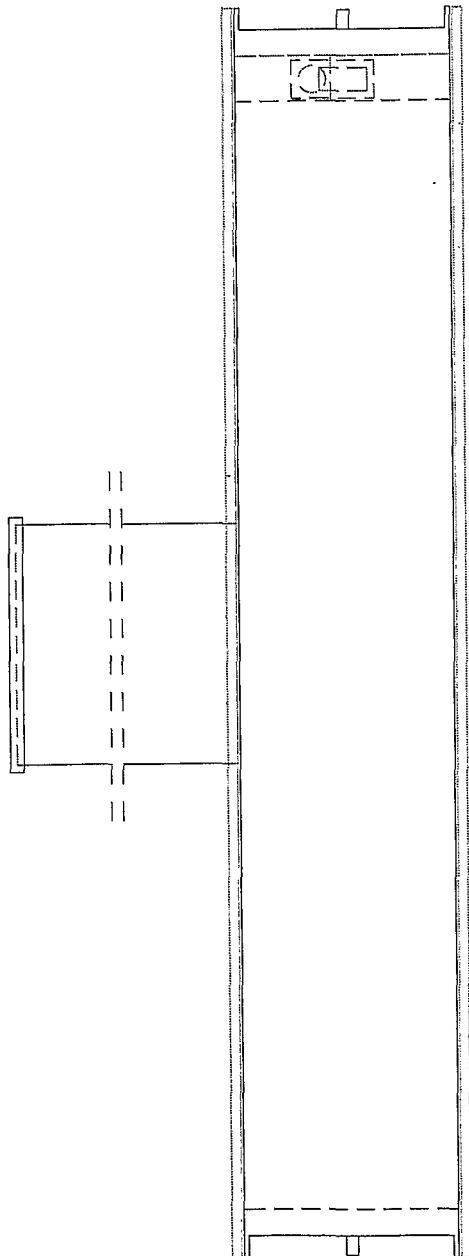

fig. 2



3

fig. 3

part. A

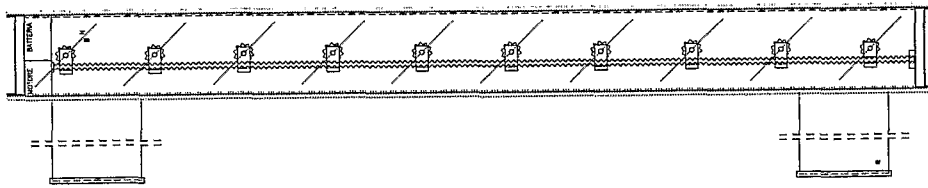

fig. 4

part. B

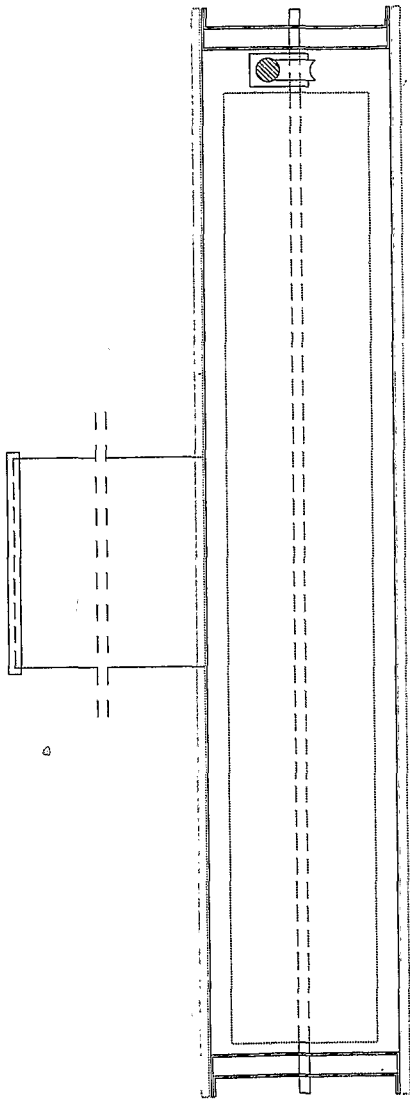

fig. 5

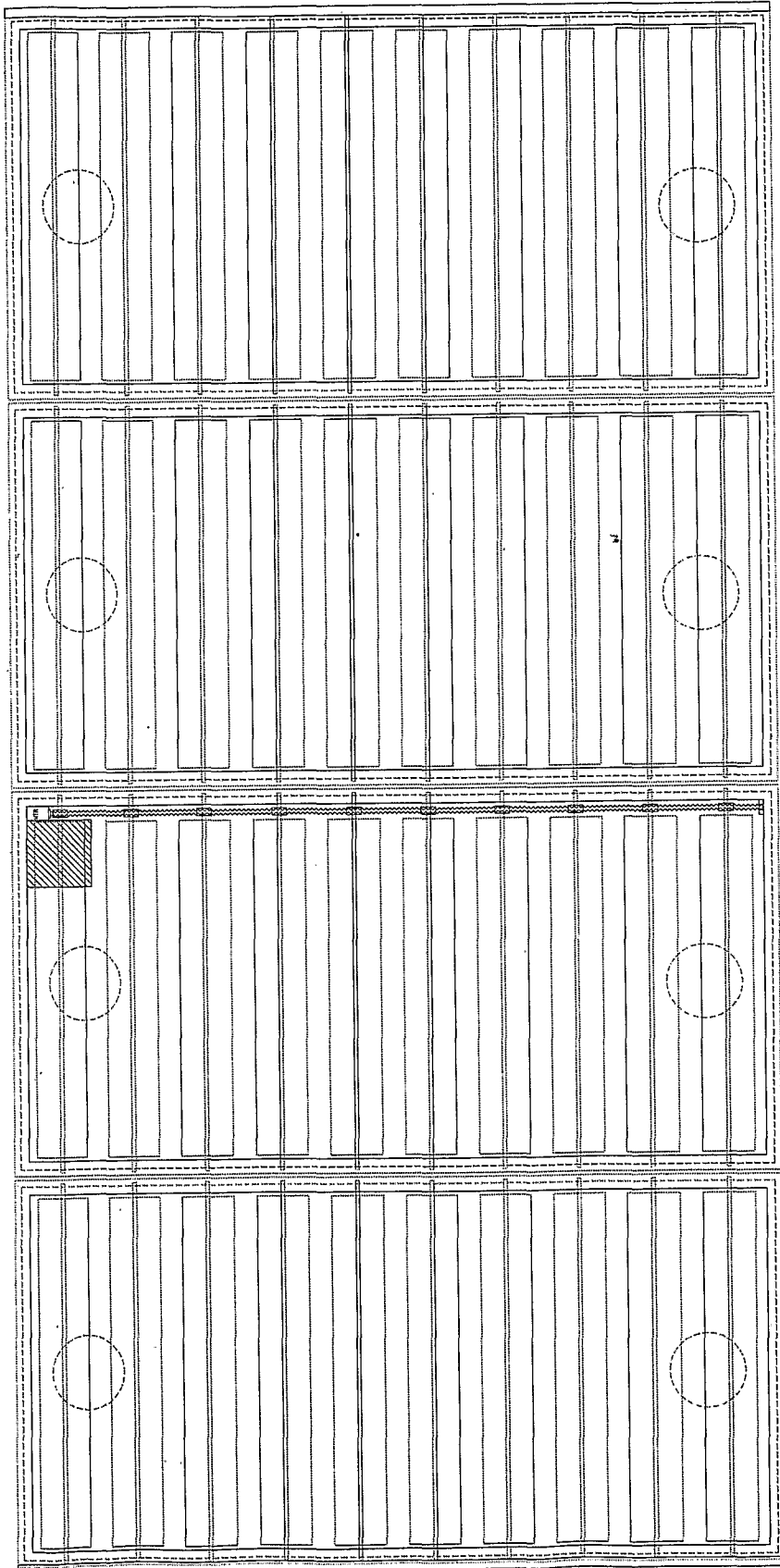

fig. 6a

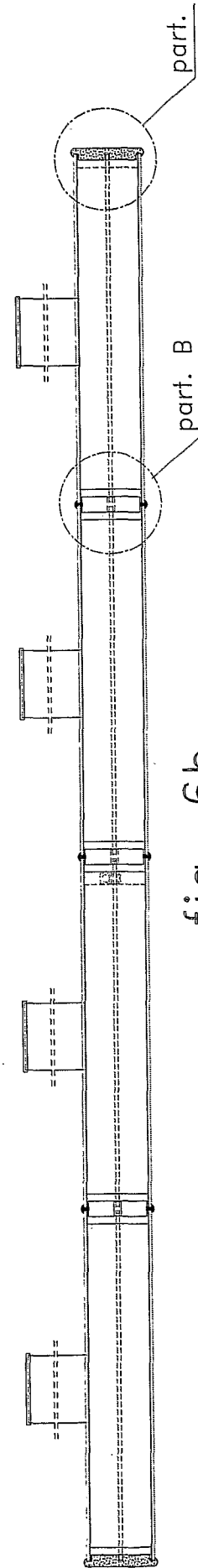

fig. 6b

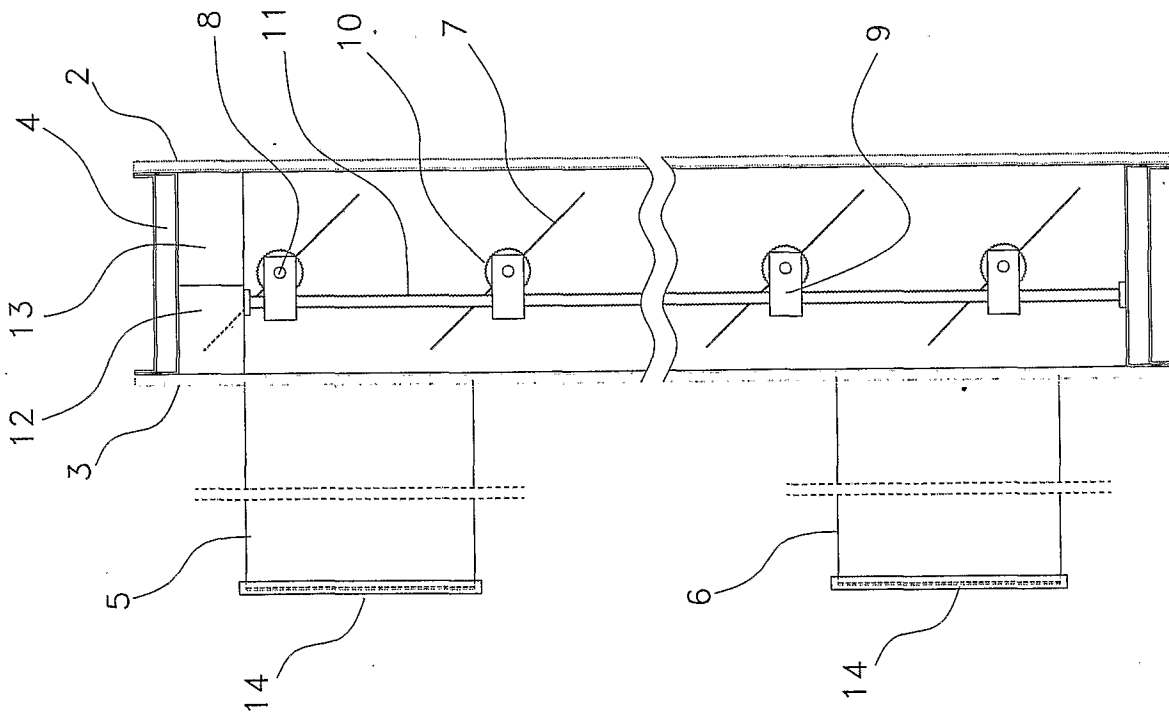

fig. 7a

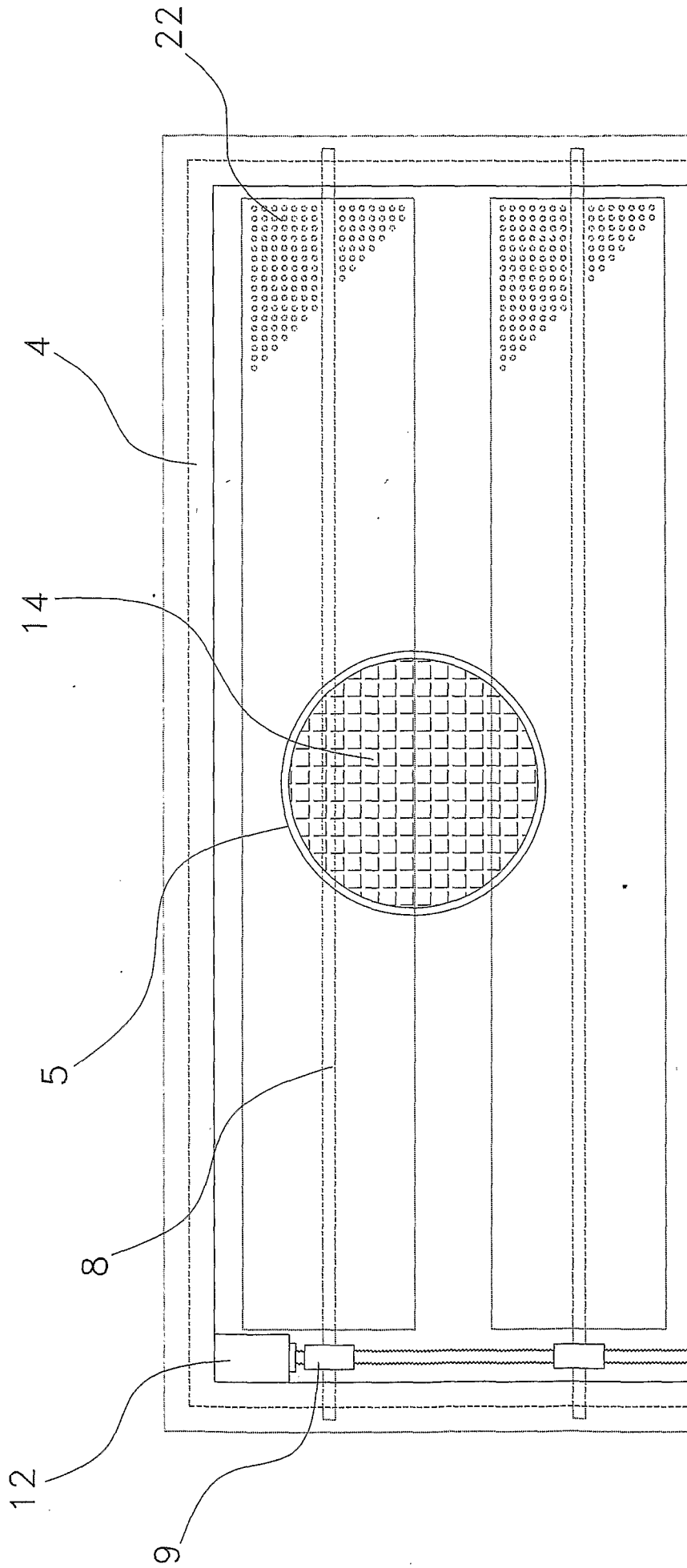

fig. 7b

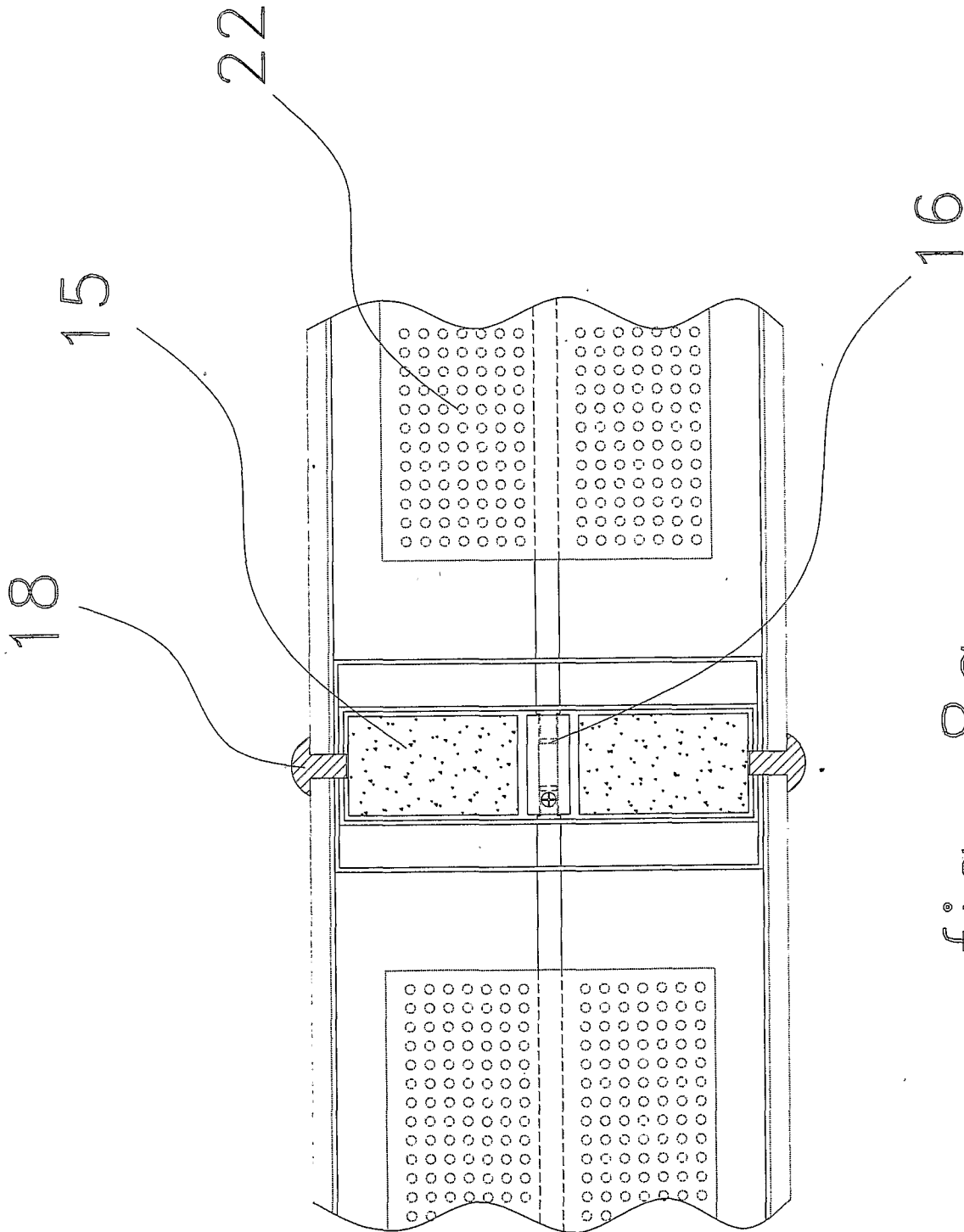

fig. 8a

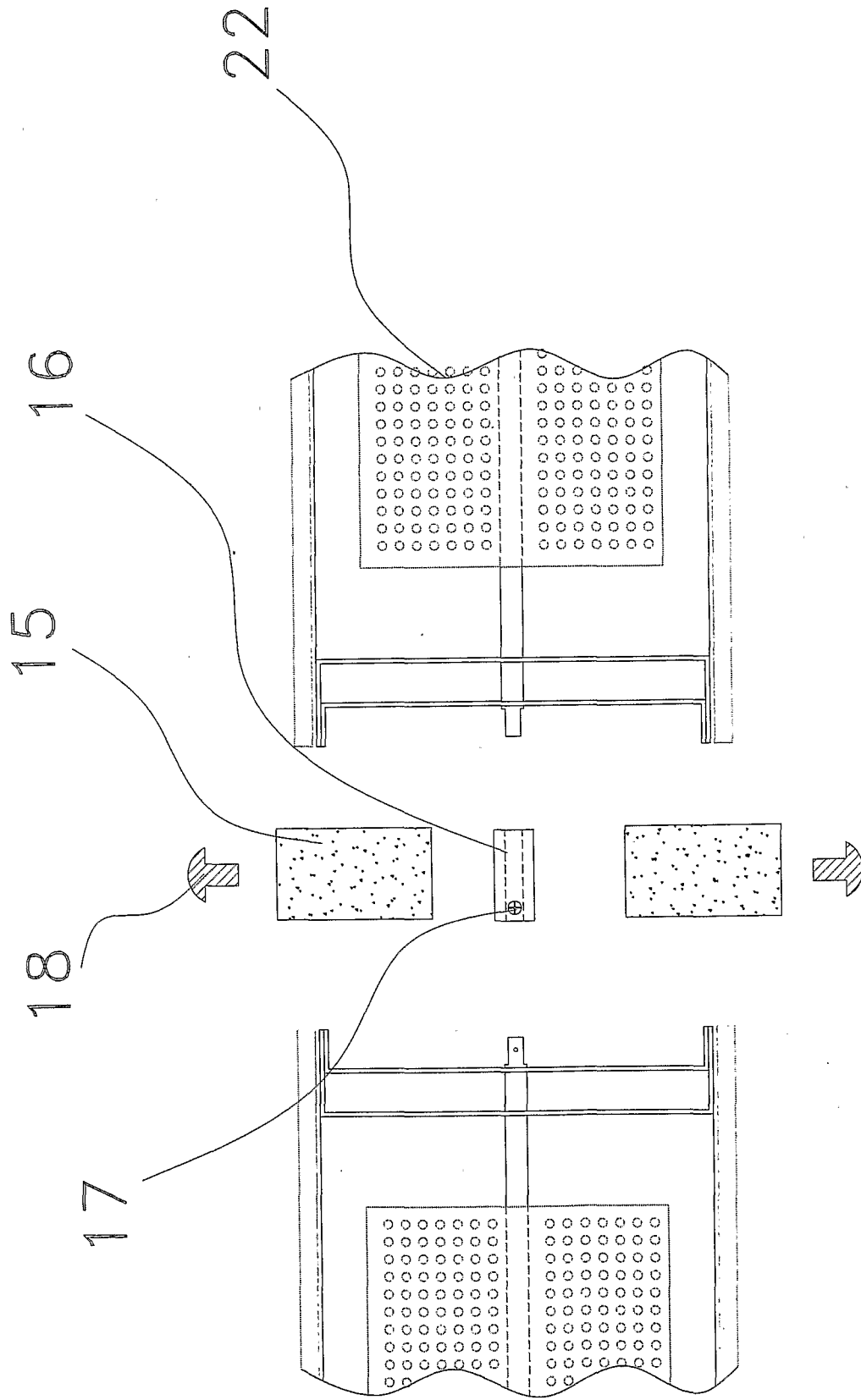

fig. 8b

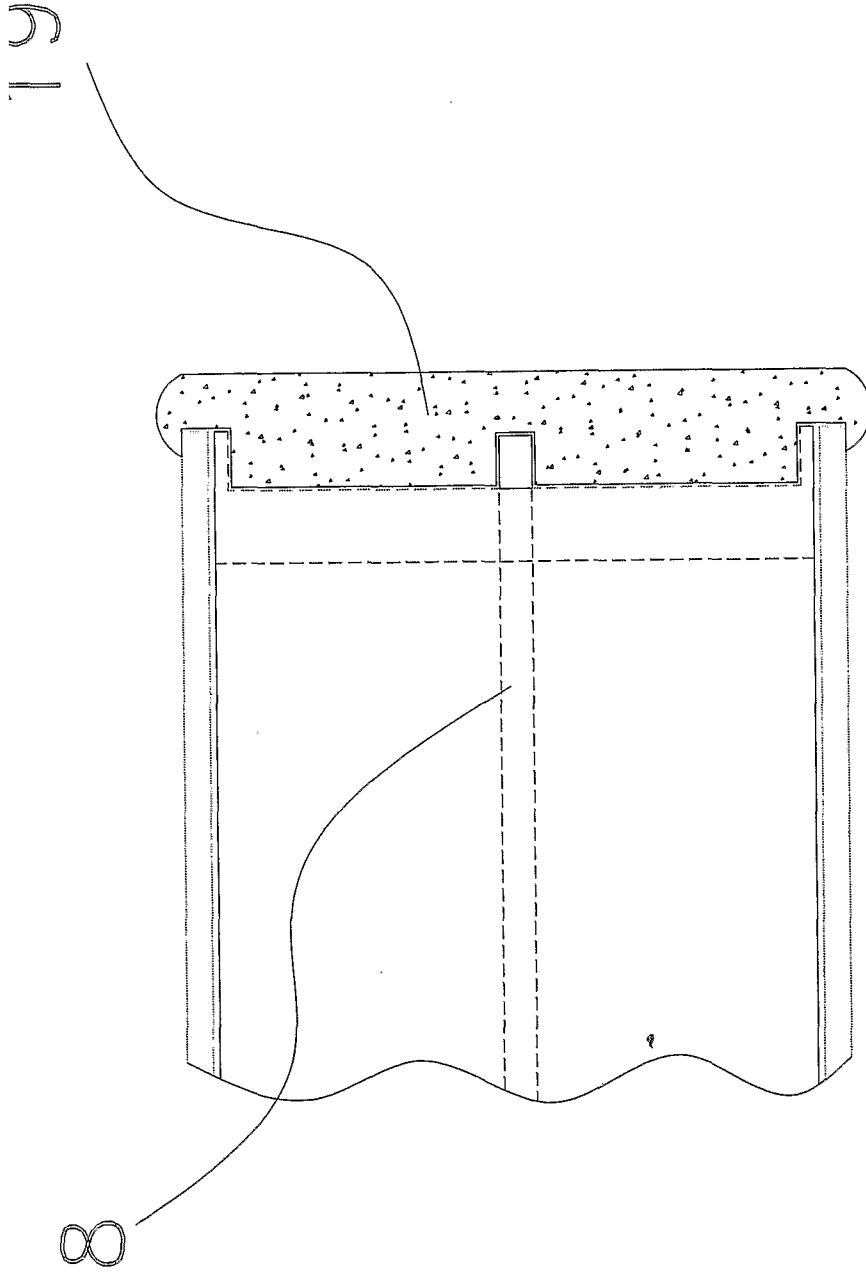

fig. 9

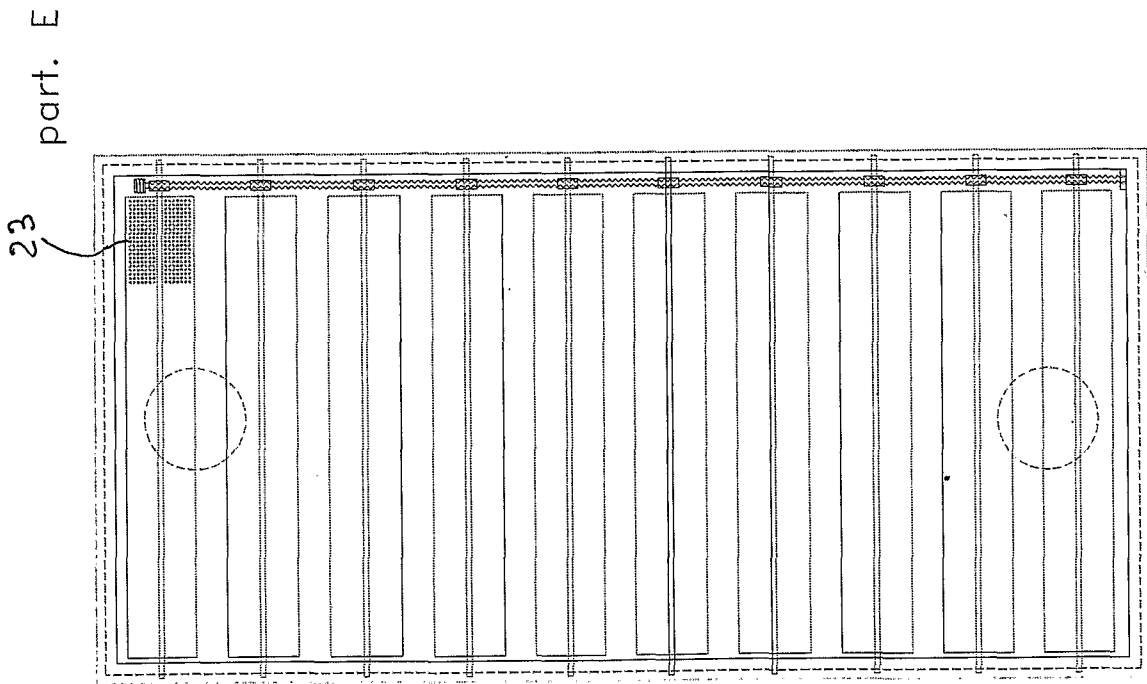

fig. 10

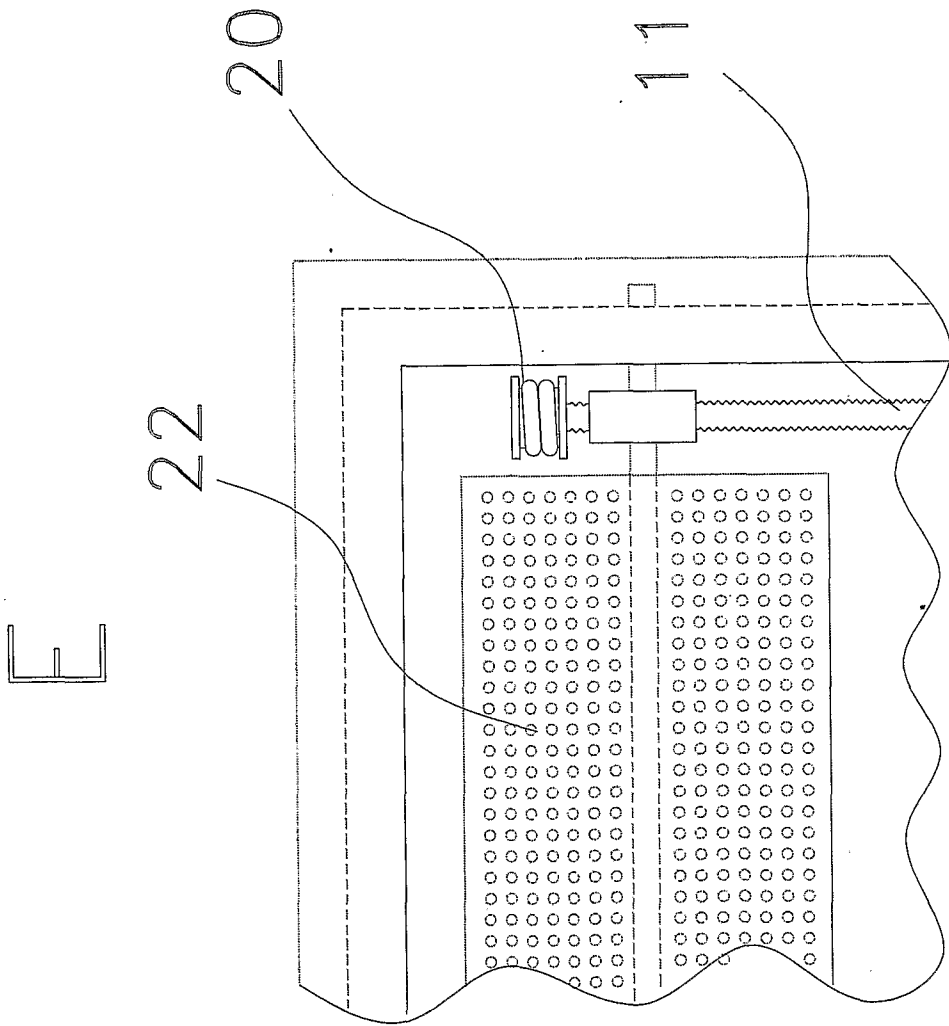

fig. 11a

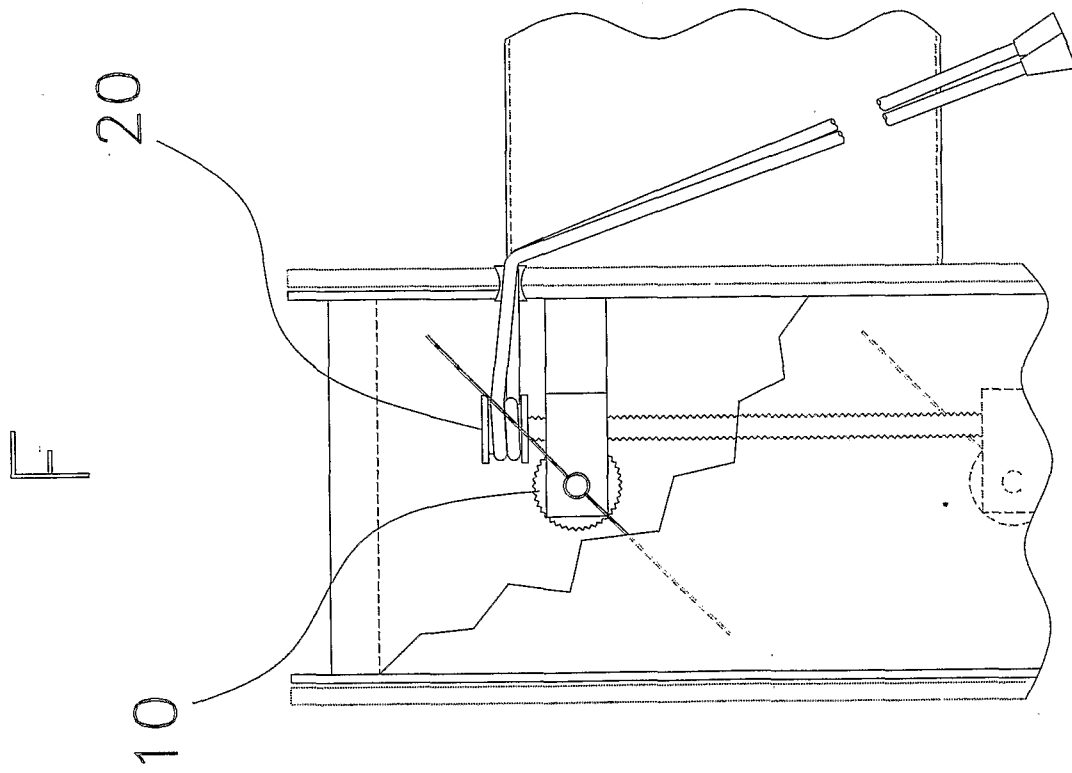

fig. 11b

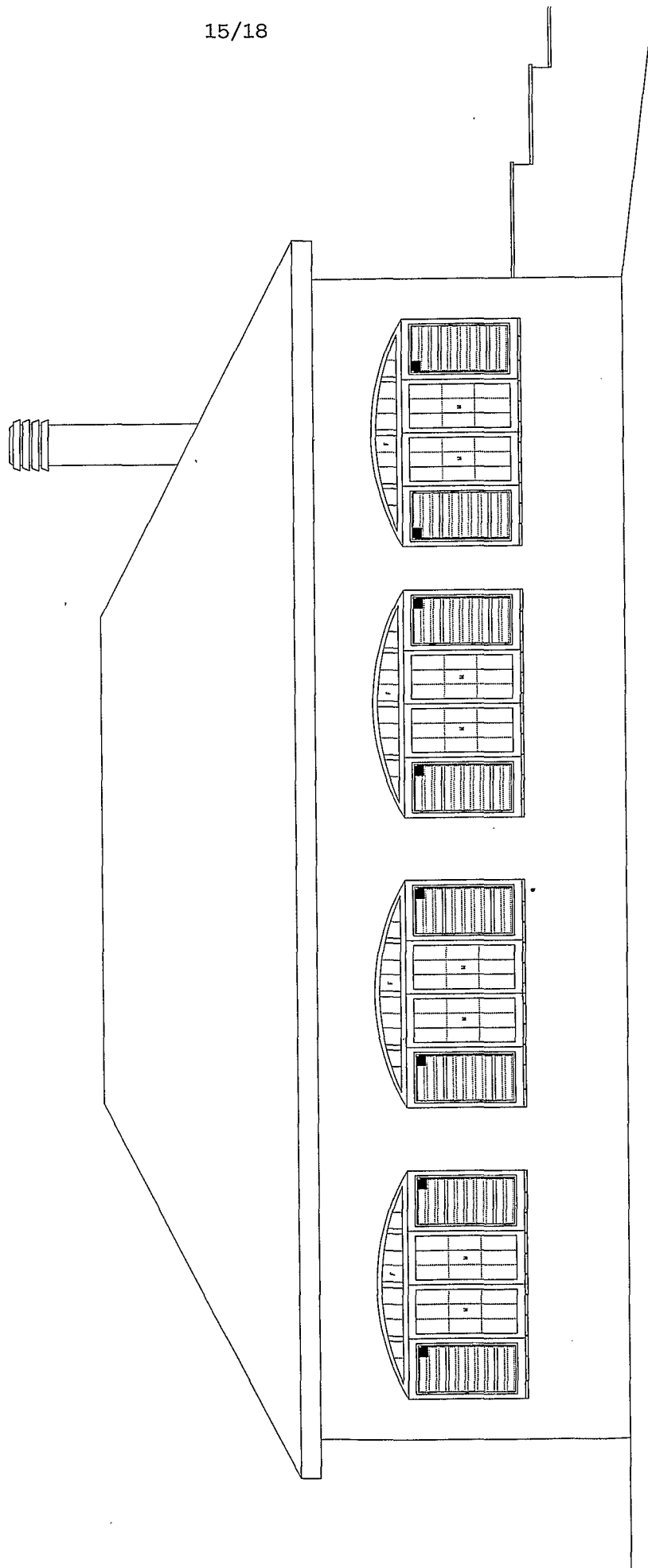

fig. 12

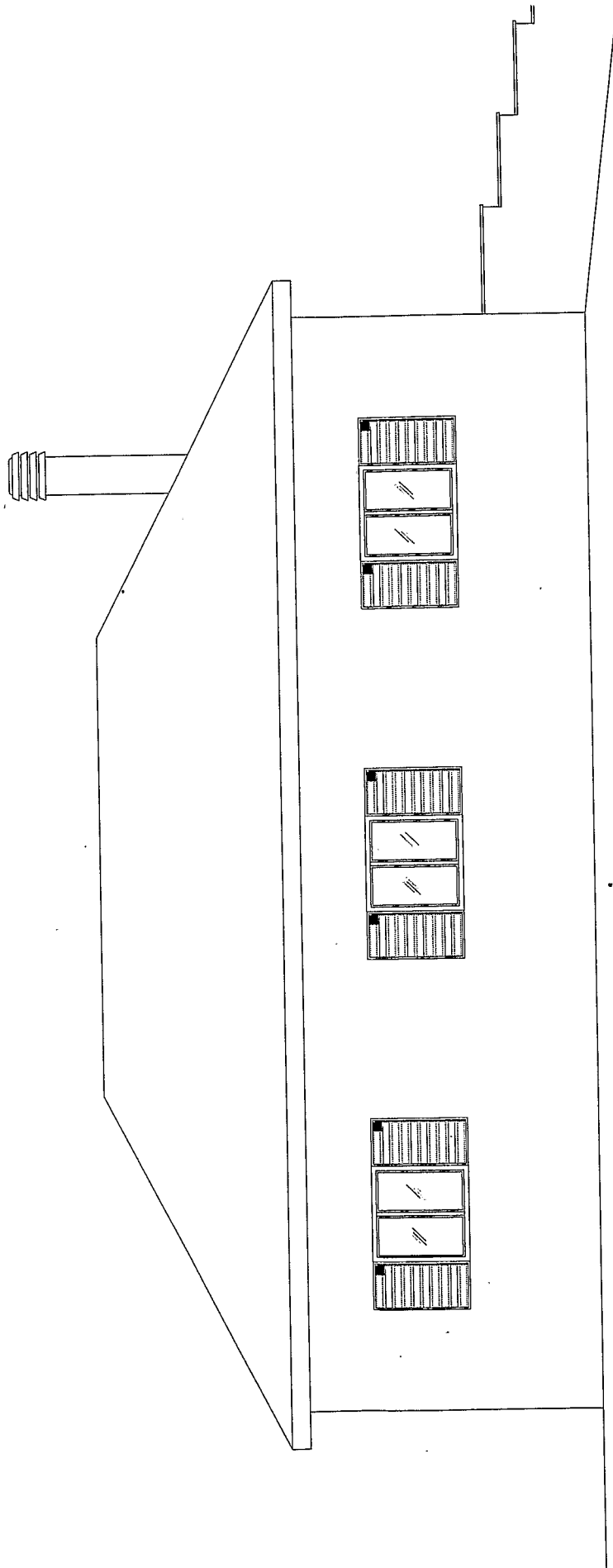

fig. 13

17/18

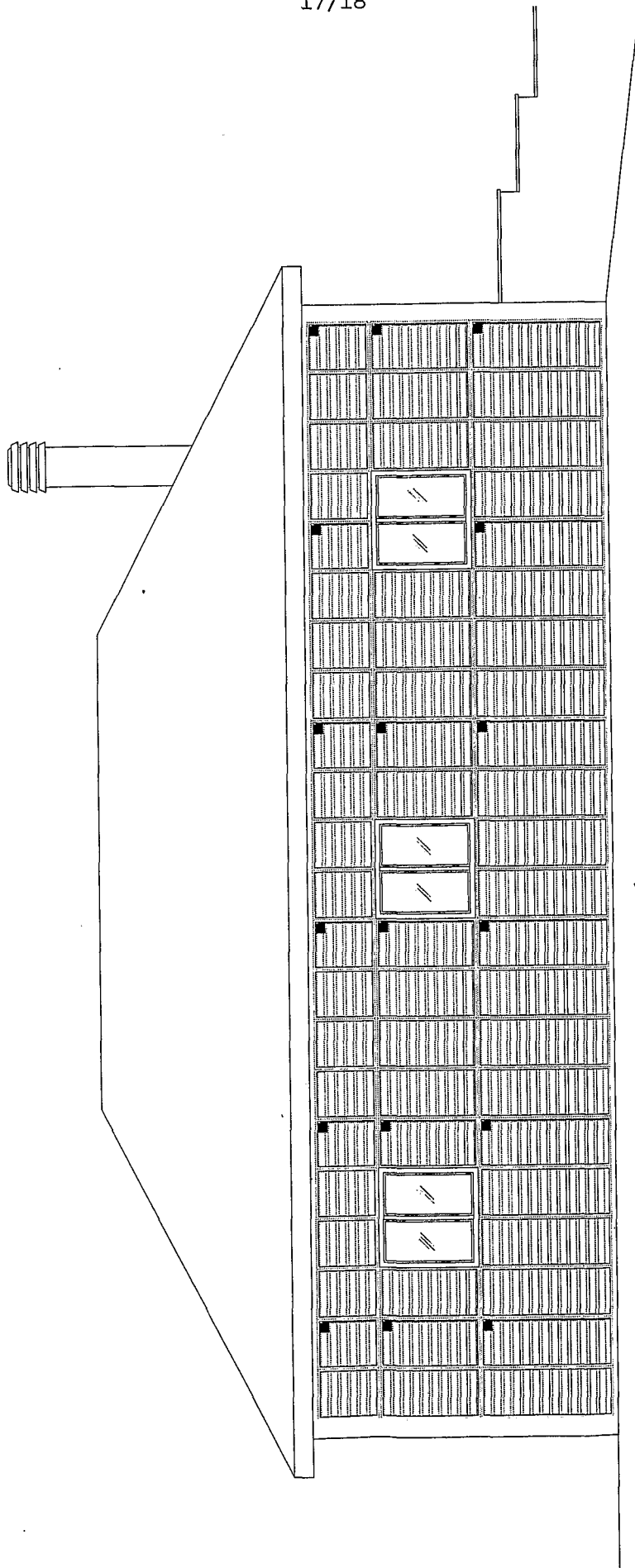

fig. 14

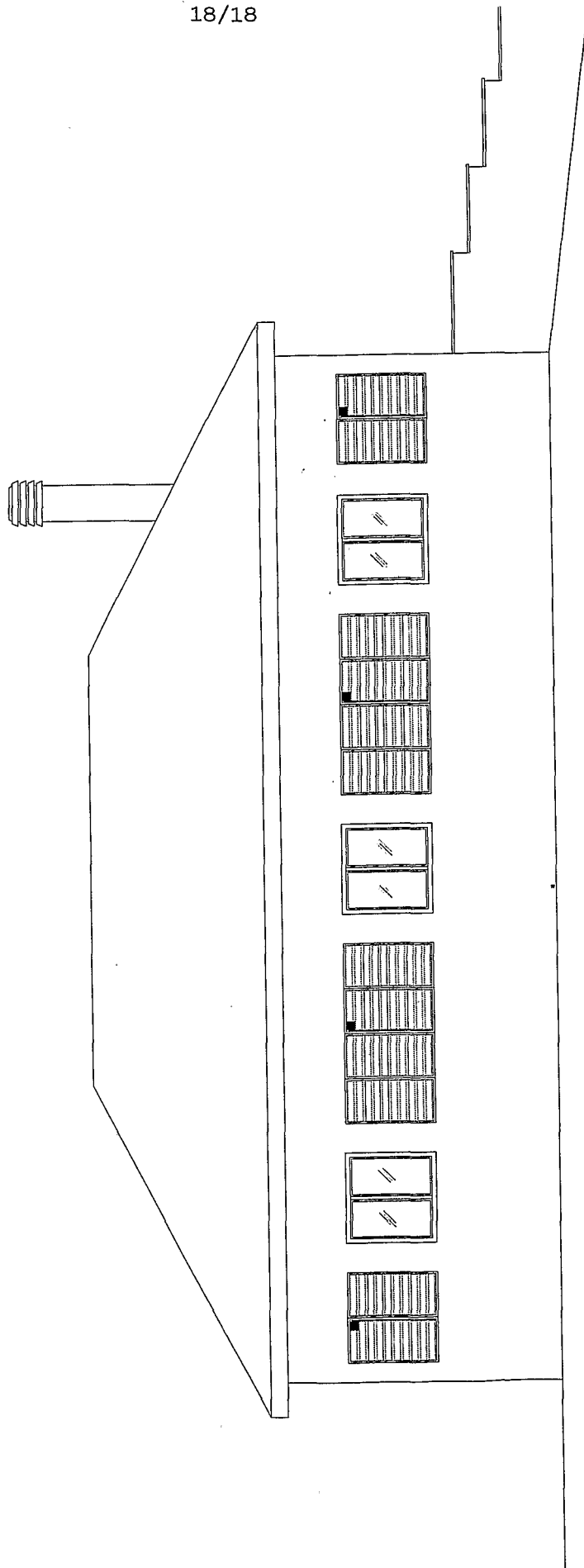

fig. 15

INTERNATIONAL SEARCH REPORT

International application No
PCT/IT2008/000525

A. CLASSIFICATION OF SUBJECT MATTER
INV. F24J2/04 F24J2/40 F24J2/54

According to International Patent Classification (IPC) or to both national classification and IPC

B. FIELDS SEARCHED

Minimum documentation searched (classification system followed by classification symbols)
F24J E04B

Documentation searched other than minimum documentation to the extent that such documents are included in the fields searched

Electronic data base consulted during the international search (name of data base and, where practical, search terms used)

EPO-Internal, WPI Data

C. DOCUMENTS CONSIDERED TO BE RELEVANT

Category*	Citation of document, with indication, where appropriate, of the relevant passages	Relevant to claim No.
Y	FR 1 207 656 A (GAUDIENZI) 18 February 1960 (1960-02-18) the whole document -----	1-8
Y	US 4 265 222 A (KAPANY NARINDER S ET AL) 5 May 1981 (1981-05-05) column 3, lines 20-56; figures 1,2 -----	1-8
A	FR 2 452 069 A (INSOLATEURS AGRICOLES STE FSE INSOLATEURS AGRICOLES STE FSE [FR]) 17 October 1980 (1980-10-17) page 3, line 23 - page 4, line 16; figures 3,4 -----	1,3,4,8
A	US 4 421 098 A (META FRANK [US]) 20 December 1983 (1983-12-20) the whole document -----	1-4,7,8
	----- -/--	

Further documents are listed in the continuation of Box C.

See patent family annex.

* Special categories of cited documents :

- *A* document defining the general state of the art which is not considered to be of particular relevance
- *E* earlier document but published on or after the international filing date
- *L* document which may throw doubts on priority claim(s) or which is cited to establish the publication date of another citation or other special reason (as specified)
- *O* document referring to an oral disclosure, use, exhibition or other means
- *P* document published prior to the international filing date but later than the priority date claimed

- *T* later document published after the international filing date or priority date and not in conflict with the application but cited to understand the principle or theory underlying the invention
- *X* document of particular relevance; the claimed invention cannot be considered novel or cannot be considered to involve an inventive step when the document is taken alone
- *Y* document of particular relevance; the claimed invention cannot be considered to involve an inventive step when the document is combined with one or more other such documents, such combination being obvious to a person skilled in the art.
- *&* document member of the same patent family

Date of the actual completion of the international search

13 July 2009

Date of mailing of the international search report

17/07/2009

Name and mailing address of the ISA/
European Patent Office, P.B. 5818 Patentlaan 2
NL - 2280 HV Rijswijk
Tel. (+31-70) 340-2040,
Fax: (+31-70) 340-3016

Authorized officer

Van Dooren, Marc

INTERNATIONAL SEARCH REPORT

International application No
PCT/IT2008/000525

C(Continuation). DOCUMENTS CONSIDERED TO BE RELEVANT

Category*	Citation of document, with indication, where appropriate, of the relevant passages	Relevant to claim No.
A	US 4 301 787 A (RICE FREDERICK H) 24 November 1981 (1981-11-24) the whole document -----	1-4,7,8
A	FR 2 530 721 A (JACOB GERARD [FR]) 27 January 1984 (1984-01-27) the whole document -----	1,3,4,7, 8
A	FR 2 442 412 A (GAUDIN JEAN CLAUDE GAUDIN JEAN CLAUDE [FR]) 20 June 1980 (1980-06-20) the whole document -----	1,3,4,7
A	DE 30 29 635 A1 (SCHWARTING KG GERAETEBAU [DE]) 4 March 1982 (1982-03-04) page 11, last line - page 12, line 1; figures 3,4 -----	2,7
A	DE 36 40 376 A1 (WEIKERT DIETRICH [DE]) 1 June 1988 (1988-06-01) abstract; figures 7,8 -----	5,6

INTERNATIONAL SEARCH REPORT

Information on patent family members

International application No

PCT/IT2008/000525

Patent document cited in search report		Publication date	Patent family member(s)	Publication date
FR 1207656	A	18-02-1960	NONE	
US 4265222	A	05-05-1981	NONE	
FR 2452069	A	17-10-1980	NONE	
US 4421098	A	20-12-1983	NONE	
US 4301787	A	24-11-1981	NONE	
FR 2530721	A	27-01-1984	NONE	
FR 2442412	A	20-06-1980	NONE	
DE 3029635	A1	04-03-1982	NONE	
DE 3640376	A1	01-06-1988	NONE	