

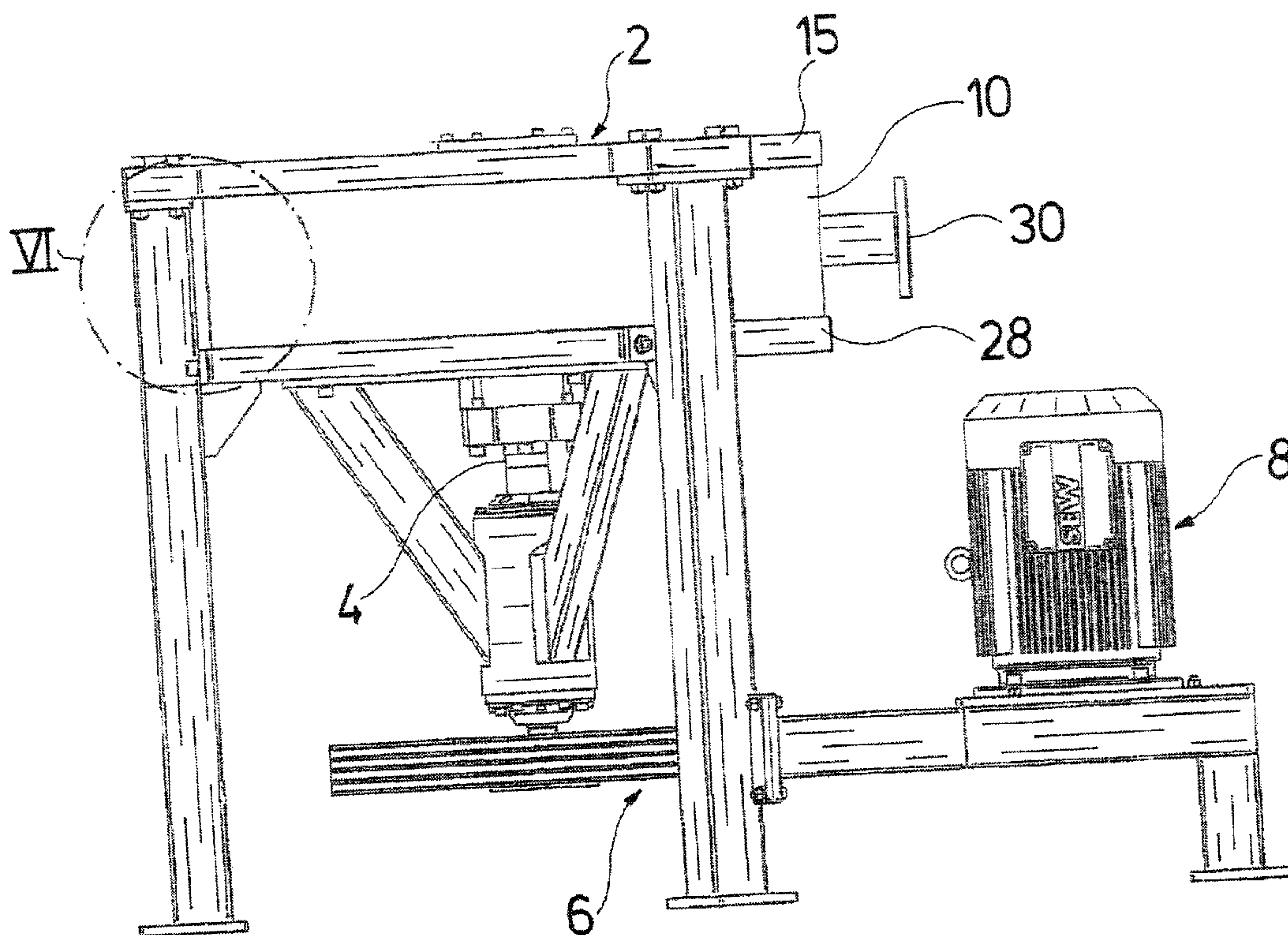

(22) Date de dépôt/Filing Date: 2010/08/04
(41) Mise à la disp. pub./Open to Public Insp.: 2011/02/13
(30) Priorité/Priority: 2009/08/13 (EP09 010 431.6)

(51) Cl.Int./Int.Cl. *B01D 69/06* (2006.01)
(71) Demandeur/Applicant:
DAUBORN MEMBRANSYSTEME FUER
WASSERBEHANDLUNG GMBH, DE
(72) Inventeur/Inventor:
REINHARDT, EUGEN, DE
(74) Agent: HOFBAUER, PATRICK J.

(54) Titre : CARTOUCHE FILTRANTE A MEMBRANE
(54) Title: MEMBRANE FILTER MODULE



(57) **Abrégé/Abstract:**

The invention relates to a membrane filter module (2) with a multitude of membranes arranged lying over one another, wherein first (26) and second (24) flow paths are formed in an alternating manner between adjacent membranes (22), of which the first flow path (26) serves for the supply and the second flow path (24) for the filtrate discharge, wherein a supply channel (20) which connects several first flow paths (26) is present and is situated within the outer periphery of the membranes (22).

Abstract

The invention relates to a membrane filter module (2) with a multitude of membranes arranged lying over one another, wherein first (26) and second (24) flow paths are formed in an alternating manner between adjacent membranes (22), of which the first flow path (26) serves for the supply and the second flow path (24) for the filtrate discharge, wherein a supply channel (20) which connects several first flow paths (26) is present and is situated within the outer periphery of the membranes (22). (Fig. 2)

MEMBRANE FILTER MODULE

Description

The invention relates to a membrane filter module.

[0001] Such membrane filter modules are known for example from EP 0 897 319 B1 as well as US 6,209,727 B1. These filter modules consist of a multitude of membranes, which are layered over one another, wherein in each case flow paths or surfaced flow channels for the supply of the medium as well as for the discharge of the filtrate, are formed in an alternating manner between the membranes. Moreover, rotors are arranged in the supply paths for the medium to be filtered and these are rotatingly driven by a central shaft, in order to distribute the supplied medium over the membranes. The supply of the medium in the flow paths between the membranes, as well as the discharge of the filtrate from the flow paths between the membranes, is effected from the outer periphery. As a rule, membrane carrier plates made of plastic which are shaped in a complicated manner and which are expensive to manufacture, are necessary as carriers for the membranes. Moreover, these modules require a relatively large construction space on account of the membrane carrier plates.

[0002] It is the object of the invention to provide an improved membrane filter module, which is less expensive to manufacture and which furthermore may be constructed in a more compact manner.

[0003] This object is achieved by a membrane filter module with the features specified in claim 1. Preferred embodiments are to be deduced from the dependent claims, the subsequent description as well as the attached figures.

[0004] As with the known membrane filter modules, the membrane filter module according to the invention is formed of a multitude of membranes, which are arranged lying over one another. The membranes lie over one another, such that their surfaces extend essentially parallel to one another and the membranes lie over one another in an essentially congruent manner. First and second flow paths are formed in an alternating manner in each case between two adjacent membranes. With a multitude of membranes, thus the first and second flow paths always alternate. The first flow path serves for the supply of the medium to be filtered, as well as for the discharge of concentrate, whilst the second flow path serves for the discharge of filtrate. A first flow path always serves for the supply of the medium to two membrane surfaces of two adjacent membranes, said surfaces lying opposite one another, on account of the alternating arrangement of the first and second flow paths.

[0005] According to the invention, it is now envisaged for the supply channel, which connects several of the first flow paths to one another and through which the medium is led to the first flow paths, not to be situated on the outer periphery of the membranes, as is known from the state of the art, but in the inside of the outer periphery. This means the channel extends through the membrane surfaces. A very compact and space-saving arrangement is created in this manner. Thereby, one preferably provides a channel, which extends through the membranes in a direction normal to the membrane surfaces, additionally to a rotor shaft. The at least one supply channel, which connects the first flow paths to one another, is preferably situated in the region of the outer half of the radius of the membranes, particularly preferably close to the outer periphery, but preferably distanced to the outer periphery.

[0006] Further preferably, in each case a membrane carrier plate is arranged between the membranes, which delimit a second flow path. These membrane carrier plates fix the membranes such that they lie to one another in an essentially plane and parallel manner. Thus, due to the alternating arrangement, a membrane carrier plate lies between a first and second membrane, a first flow path is formed between the second and third membrane, again a membrane carrier plate lies between the third and fourth membrane, and a first flow path is again formed between the fourth and fifth membrane, etc. The second flow paths thereby in each case run along the surfaces of the membrane carrier plates, between the surfaces of the membrane carrier plate and the adjacent membranes.

[0007] The membrane carrier plates are in each case preferably designed as disks with plane surfaces. This permits a very inexpensive design, since the membrane carrier plates may be simply cut from a plate material, and require no structuring on the surface at all. Thus, the membrane carrier plates are further preferably manufactured from metal, for example rust-free stainless steel. This permits the membrane carrier plates to be designed significantly more thinly with the same stability, than was the case with the membrane carrier plates of plastic used in the state of the art. The thinner design of the membrane carrier plates, with a multitude of membranes layered over one another, with membrane carrier plates lying therebetween, as a whole leads to a significantly reduced construction length of the complete membrane filter module.

[0008] Further preferably, in each case a spacer material, through which the second flow path runs, is arranged between the surfaces of the membrane carrier plate and the adjacent membranes. The spacer material is a porous material, for example a non-woven, through which the filtrate may flow. The spacer material thus keeps the adjacent membranes at a distance to the surfaces of the membrane carrier plates, so that a surfaced flow path for the discharge of filtrate is created between the membrane and the membrane carrier plate.

[0009] It is further preferable for the supply channel to be formed in each case by way of at least one hole in the membrane carrier plates. Such a hole may be cut into the plane membrane carrier plates in a very simple manner or incorporated in another manner. Thus a supply channel to the first flow paths through a part, preferably through the complete membrane filter module, is created by way of the successive holes of the individual membrane carrier plates.

[0010] The two membranes enclosing the membrane carrier plate, i.e. the membranes which border the membrane carrier plate at the opposite surfaces of the membrane carrier plate, are further preferably connected to one another, preferably welded, on the inner periphery of the hole in the membrane carrier plate. Thus, an annular welding seam may be formed on the inner periphery of the hole. Then, preferably, a hole through the membrane is likewise formed in the inside of the annular welding seam, so that the supply channel there may extend through the membrane. The membranes may however also be sealingly connected in another suitable manner, e.g. bonded or clamped. The supply channel in this manner is merely formed by way of holes in the membrane plates and the membrane plate carriers, which are stacked on one another, without an additional pipe or likewise being necessary. The holes in the several membranes or membrane carrier plates may thereby lie over one another in a flush manner. According to a further preferred embodiment however, the holes in the individual membrane carrier plates and which define the supply channel, and accordingly the holes in the membranes and which are formed in the region of these holes, may be offset to one another. This means that with the multitude of membrane carrier plates which are stacked over one another, the individual holes in the membrane carrier plates do not lie over one another in a flush manner, but offset to one another from membrane plate to membrane plate. An improved distribution of the supplied medium in the filter module is achieved in this manner. Preferably, the membrane carrier plates are all designed in an identical manner, which means the holes are also designed in an identical manner. For the offset of the holes, the membrane carrier plates are merely arranged offset to one another in the angular position about their middle axis. In this manner, a helical course of the position of the holes may be achieved over the whole length of the membrane filter module. However, it is also conceivable to arrange the holes flush with one another in sections, and to merely offset the position of the holes to one another between the individual sections.

[0011] The first flow paths between the membranes, as described above, are preferably designed as free spaces, in which in each case a rotor is located, which serves for distributing the medium in the free space, so that the medium flows simultaneously over the membranes. The supply is located where the rotor moves over the membrane with the greatest speed, by way of the arrangement of the supply channel in the outer half of the membrane. Thus the medium flowing in through the supply channel is distributed in a particularly effective manner.

[0012] The individual rotors are preferably arranged on a common motor shaft which extends in each case through a central hole in the membrane carrier plates. The central rotor shaft, as is known from known membrane filter modules, may be rotatably driven by a drive motor, which is preferably arranged on a lower side of the membrane filter module. The central hole, as described, is arranged distanced to the hole for the supply channel.

[0013] The membranes enclosing a membrane carrier plate are furthermore connected to one another also at the inner periphery of the central hole, preferably welded, and comprise a hole in the inside of the thus formed annular seam or welding seam, through which hole the rotor shaft extends. The design of the welding seam, inasmuch as this is concerned, is similar to the welding seam in the hole for the supply channel. Here too, a suitable other sealed connection between the membranes may be applied.

[0014] The second flow paths, which serve for the filtrate discharge, are preferably open to the outer periphery of the membranes, which means the filtrate exits at the outer periphery of the filter module and there is collected in a casing, which includes the filter, and led away. The medium to be filtered is preferably introduced into the supply channel through a hole in the base plate or the upper plate of the stack of membranes. Then accordingly, the concentrate is led out of the supply channel at the opposite end of the membrane filter module.

[0015] Further preferably, in each case, an outer spacer ring is arranged on the outer periphery of the membrane, between the membranes which in each case delimit the first flow path. This ensures that the membranes delimiting the first flow path, as well as the membrane carrier plates lying behind these, are held at a defined distance, so that a free space arises between the membranes, in which the rotor may rotate.

[0016] The complete arrangement of the membranes lying over one another, with spacer materials and membrane carrier plate, which lie therebetween as the case may be, is preferably fixed by way of guide rods, which are arranged outside the outer periphery of the membranes. This permits a very simple assembly. The guide rods thereby fix the membrane carrier plates with the membranes arranged thereon, thereby in particular in the radial direction, so that they may not displace to one another in the radial direction. In the axial direction, the membranes lying over one another, with the membrane carrier plates lying therebetween, are fixed by way of a base plate and a cover plate, or are pressed onto one another.

[0017] For fixation, the guide rods are preferably in contact with the outer periphery of membrane carriers arranged between the membranes and/or of the spacer rings. Preferably, the spacer rings as well as the membrane carrier plates are fixed on the outer periphery by way of guide rods.

[0018] For this, spacer pieces may be arranged on the guide rods, which in each case are in contact with the outer periphery of the membrane carrier plates and the outer spacer rings. The spacer pieces may thereby be designed, such that in each case a spacer piece is envisaged for contacting the spacer ring and an adjacent membrane carrier plate. The spacer pieces may be profiled, in order, with different outer diameters of spacer ring and membrane carrier plate, to be able to contact both on the outer periphery. Thus the spacer ring may preferably have a larger outer diameter than the membrane carrier plate.

[0019] The invention is hereinafter described by way of the attached figures. In these are shown in:

Fig. 1 schematically, a membrane filter system with a membrane filter module, according to the invention,

Fig. 2 a plan view of the membrane filter module according to Fig. 1,

Fig. 3 a sectioned view along line III-III in Fig. 2,

Fig. 4 enlarged, the detail IV from Fig. 3,

Fig. 5 enlarged, the detail V from Fig. 3 and

Fig. 6 an enlarged, sectioned view of the detail VI in Fig. 1.

[0020] The membrane filter system shown in Fig. 1 comprises a membrane filter module 2, in which a central rotor shaft 4 is arranged, said shaft being rotatably driven via a belt drive 6 by an electric motor 8.

[0021] Fig. 2 shows a plan view of the part of the membrane filter module 2, which is situated in the inside of the housing 10. In Fig. 2, from above, one may recognise the uppermost membrane carrier plate 12. An outer spacer ring 14 is placed onto this at the outer periphery of this plate. This spacer ring 14 ensures that a defined distance to the membrane carrier plate 12 or cover plate 15, which lies thereabove, remains. Moreover, the spacer ring 14 on the outer periphery holds the membrane, which lies over the membrane carrier plate 12, bearing on the membrane carrier plate 12 or on a spacer

material arranged on this. The membrane carrier plates 12 itself is formed as a plane disk and is cut preferably from a plane sheet metal, preferably stainless steel sheet.

[0022] A rotor 16 is arranged above the membrane carrier plate 12, in the free space enclosed by the spacer ring 14, and this rotor is connected to the rotor shaft 4 in a rotationally fixed manner and is thus rotatably driven by this. The rotor shaft 4 extends through a central hole 18 in the membrane carrier plate 12. The membrane carrier plate 12 moreover comprises a second hole, which is arranged radially to the outside, distanced to the central hole 18. The hole 20 forms part of a supply channel, through which the medium or fluid to be filtered is supplied. The rotor 16 distributes this fluid over the membrane.

[0023] The further construction of the membrane filter module is now explained by way of the sectioned view in Fig. 3, as well as the enlarged detail views in Figures 4 to 6.

[0024] The membrane filter module 2 comprises a multitude of membranes 22 lying over one another. In the shown example, twenty membranes 22 are provided, which are arranged over ten membrane carrier plates 12. The membranes 22 do not bear directly on the membrane carrier plates 12, but are held at a distance to the membrane carrier plate 12 by a spacer material 24. The spacer material 24 is fluid permeable, so that it forms a surfaced flow path between the membrane 22 and the membrane carrier plate 12 which borders this. The filtrate is discharged through the spacer material 24.

[0025] As described, the supply of the medium or fluid to be filtered, is effected through the holes 20. Such a hole 20 is formed in each of the membrane carrier plates 12. Thereby, the circular membrane carrier plates 12 are all designed in an identical manner, but are arranged rotated to one another with respect to the longitudinal axis of the rotor shaft 4, in a manner such that the holes 20 in the individual membrane carrier plates 12 are not flush with one another. The medium to be filtered is led through the holes 20 into first flow paths 26 between the membranes 22. The first flow paths 26 form surfaced flow paths in each case between two membranes 22, at their sides which are away from the membrane carrier plates 12. The first flow paths 26 in the form of free spaces and the second flow paths formed by the spacer material 24, thus alternate in a regular manner between the membranes 22. The rotors 16 are arranged in each case in the free spaces forming the first flow paths 26. The discharge of concentrate is likewise effected through the supply channel formed by the holes 20. The medium to be filtered is introduced into the thus formed supply channel from the lower side, i.e. through the base plate 28, and the concentrate is led away through an opening at the opposite end of the membrane stack, i.e. through the cover plate 15.

[0026] The filtrate flows through the spacer material 24 radially outwards and exits to the outside at the outer periphery between the outer spacer rings 14. Then it is collected in the housing 10 and may be discharged via an outlet 30 in the housing 10.

[0027] The membranes 22 which are situated on both sides of the respective membrane carrier plate 12, are welded to one another in the central holes 18, as well as the holes 20. An annular welding seam situated on the inner periphery of the hole 20, as well as a welding seam situated on the inner periphery of the central hole 18, are provided for this. The membranes 22 are also broken through in the holes 18 and 20, i.e. within the annular welding seams, so that the rotor shaft 4 may extend through the membranes 22, and a free passage for the medium to be supplied is formed in each case in the holes 20. It is ensured by way of the sealed connection of the membrane 22 situated on both sides of the membrane carrier plate 12, on the inner periphery of the holes 18 and 20, that the medium to be filtered may not enter directly from the first flow paths 26 or the central hole 20, into the region between the membranes 22 and the membrane carrier plates 12, in which the spacer material 24 is arranged. In this manner, one ensures that a passage into this region is only possible through the membrane 22.

[0028] A simpler and compacter construction of the membrane filter module 2 is ensured by way of the supply of the medium to be filtered, through the holes 20, which are situated in the inside of the outer periphery of the membranes 22 and the membrane carrier plates 12, since no supply channels need to be placed on the outer periphery. Simultaneously, a good distribution of the medium to be supplied is achieved in the free spaces 26 between the membranes 22, in which the rotors 12 are arranged, since the medium enters into these spaces in a direct manner and does not need to be introduced into these from the outer periphery. Moreover, a very simple construction of the membrane carrier plates 12 is possible. These require no special shaping or profiling on their surfaces whatsoever, but may be designed as smooth disks. Inasmuch as this is concerned, they may be cut from a sheet metal. This permits a thinner construction compared to a membrane carrier plate 12 formed of plastic, by which means the total axial length of the membrane filter module is shortened.

[0029] Guide rods 32 are arranged on the outer periphery of the membrane carrier plates 12 and the membranes 22, for centering or fixing the membrane carrier plates 12 in the radial direction with respect to the longitudinal axis X of the rotor shaft 4. At least three guide rods 32 are distributed uniformly over the outer periphery of the membrane filter module 2, so that movements of the membrane carrier plates 12 may be prevented in all radial directions. It is to be understood that one may also arrange more than three guide rods 32. Spacer pieces 34 are placed onto the guide rods 32, wherein a spacer piece 34 is provided for each step of the membrane filter module 2, consisting of a membrane carrier plate 12 and an associated outer spacer ring 14. The spacer pieces 34 have a central

bore, through which the guide rod 32 extends. Moreover, they comprise two sections 36 and 38 in the axial direction. The section 36, whose axial length corresponds to the thickness of the membrane carrier plate 12 and the layers of spacer material 34 bearing on both sides, has a larger outer diameter than the section 38. The section 38 corresponds in its axial length to the axial thickness of a spacer ring 14. The spacer rings 14 have a larger outer diameter than the membrane carrier plates 12. The section 36 with the largest diameter of the spacer piece 34 bears on the outer periphery of the membrane carrier plate 12, whilst the section 38 with the smaller diameter bears on the outer periphery of the spacer ring 14. In this manner, the membrane carrier plate 12, as well as the spacer ring 14 are fixed in the radial direction between the guide rods 32 with the applied spacer pieces 34. The spacer pieces 34 additionally ensure that the individual membrane carrier plates 12 are held at a defined distance to one another, and the spacer material 24 at the outer periphery between the spacer rings 14 may not be compressed beyond a certain amount when the complete membrane filter module 2 is pressed together by way of tightening the base plate 28 and cover plate 15. The outer periphery between the guide rods 32 remains free, by way of the fact that only few, preferably three guide rods 32 are arranged distributed on the outer periphery, so that in these regions, the filtrate may exit radially to the outside out of the spacer material 24.

List of reference numerals

2	-	membrane filter module
4	-	rotor shaft
6	-	belt drive
8	-	drive motor
10	-	housing
12	-	membrane carrier plate
14	-	outer spacer ring
15	-	cover plate
16	-	rotor
18	-	central hole
20	-	hole
22	-	membrane
24	-	spacer material
26	-	first flow path
28	-	base plate
30	-	outlet
32	-	guide rod
34	-	spacer piece
36, 38	-	sections of the spacer piece
X	-	longitudinal axis

THE EMBODIMENTS OF THE INVENTION IN WHICH AN EXCLUSIVE PROPERTY OR PRIVILEGE IS CLAIMED ARE DEFINED AS FOLLOWS:

1. A membrane filter module (2) with a multitude of membranes (22) arranged lying over one another, wherein first (26) and second (24) flow paths are formed in an alternating manner between adjacent membranes (22), of which the first flow path (26) serves for the supply and the second flow path (24) for the filtrate discharge, characterised in that a supply channel (20) which connects several first flow paths (26) is present and is situated within the outer periphery of the membranes (22).
2. A membrane filter module (2) according to claim 1, characterised in that a membrane carrier plate (12) is arranged in each case between the membranes (22), which delimit a second flow path.
3. A membrane filter module (2) according to claim 2, characterised in that the membrane carrier plate (12) is designed as a disk with plane surfaces.
4. A membrane filter module (2) according to claim 2 or 3, characterised in that a spacer material (24) is arranged in each case between the surfaces of the membrane carrier plate (12) and the adjacent membranes (22), through which spacer material the second flow path runs.
5. A membrane filter module (2) according to one of the claims 2 to 4, characterised in that the supply channel is formed in each case by way of at least one hole (20) in the membrane carrier plates (12).
6. A membrane filter module (2) according to claim 5, characterised in that the two membranes (22) which enclose a membrane carrier plate (12), are welded to one another at the inner periphery of the hole (20) in the membrane carrier plate (12).
7. A membrane filter module (2) according to claim 5 or 6, characterised in that the holes (20) defining the supply channel are arranged displaced to one another in the individual membrane carrier plates (12).
8. A membrane filter module (2) according to one of the preceding claims, characterised in that the first flow paths (26) are formed as free spaces between the membranes (22), in which free spaces a rotor (16) is arranged in each case.

9. A membrane filter module according to claim 8, characterised in that the rotors (16) are arranged on a common rotor shaft (4), which extends in each case through a central hole (18) in the membrane carrier plates (12).
10. A membrane filter module according to claim 9, characterised in that the membranes (22) which in each case enclose a membrane carrier plate (12), are welded to one another on the inner periphery of the central hole (18).
11. A membrane filter module according to one of the preceding claims, characterised in that the second flow paths (24) are opened to the outer periphery of the membranes (22).
12. A membrane filter module according to one of the preceding claims, characterised in that in each case an outer spacer ring (14) is arranged on the outer periphery of the membranes (22), between the membranes (22) which delimit a first flow path (26)
13. A membrane filter module according to one of the preceding claims, characterised in that the arrangement of membranes (22) lying over one another is fixed by way of guide rods (32) which are arranged outside the outer periphery of the membranes (22).
14. A membrane filter module according to claim 13, characterised in that the guide rods (32) are in contact with the outer periphery of membrane carrier plates (12) arranged between the membranes (22) and/or of the outer spacer rings (14).
15. A membrane filter module according to claim 14, characterised in that spacer pieces (34) are arranged on the guide rods (32), which in each case are in contact with the outer periphery of the membrane carrier plates (12) and of the outer spacer rings (14).

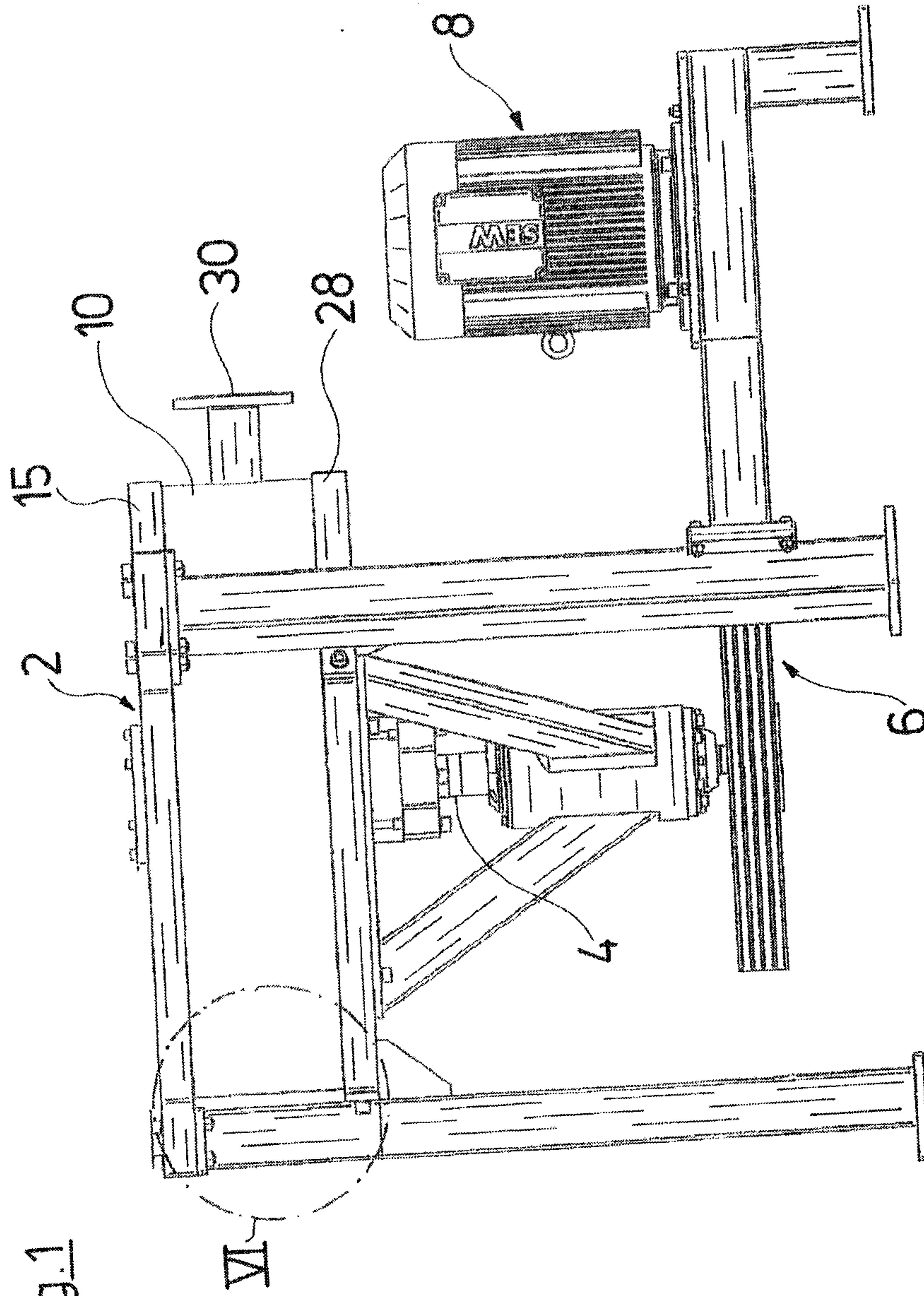

Fig.1

Fig.2

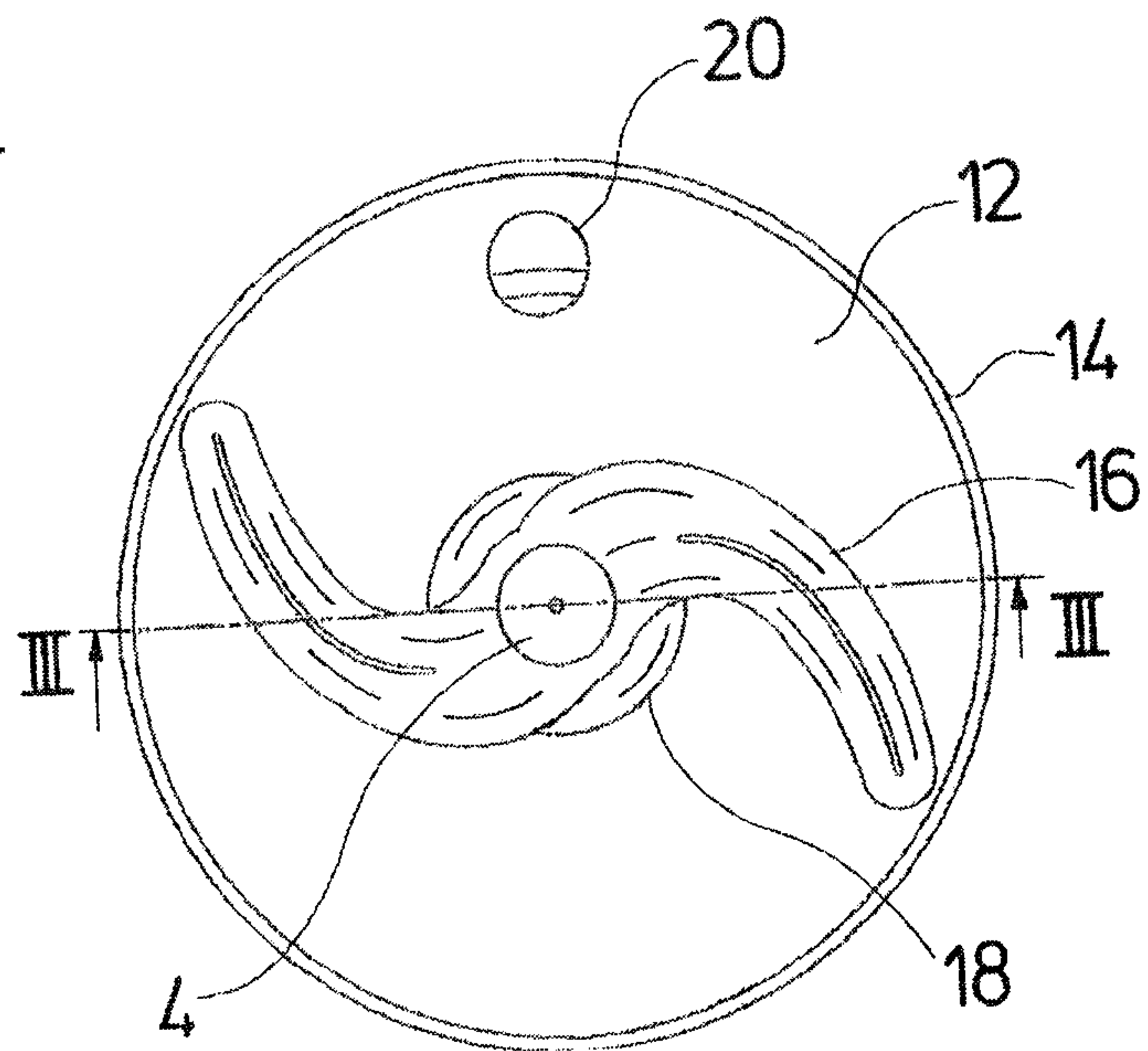

Fig.3

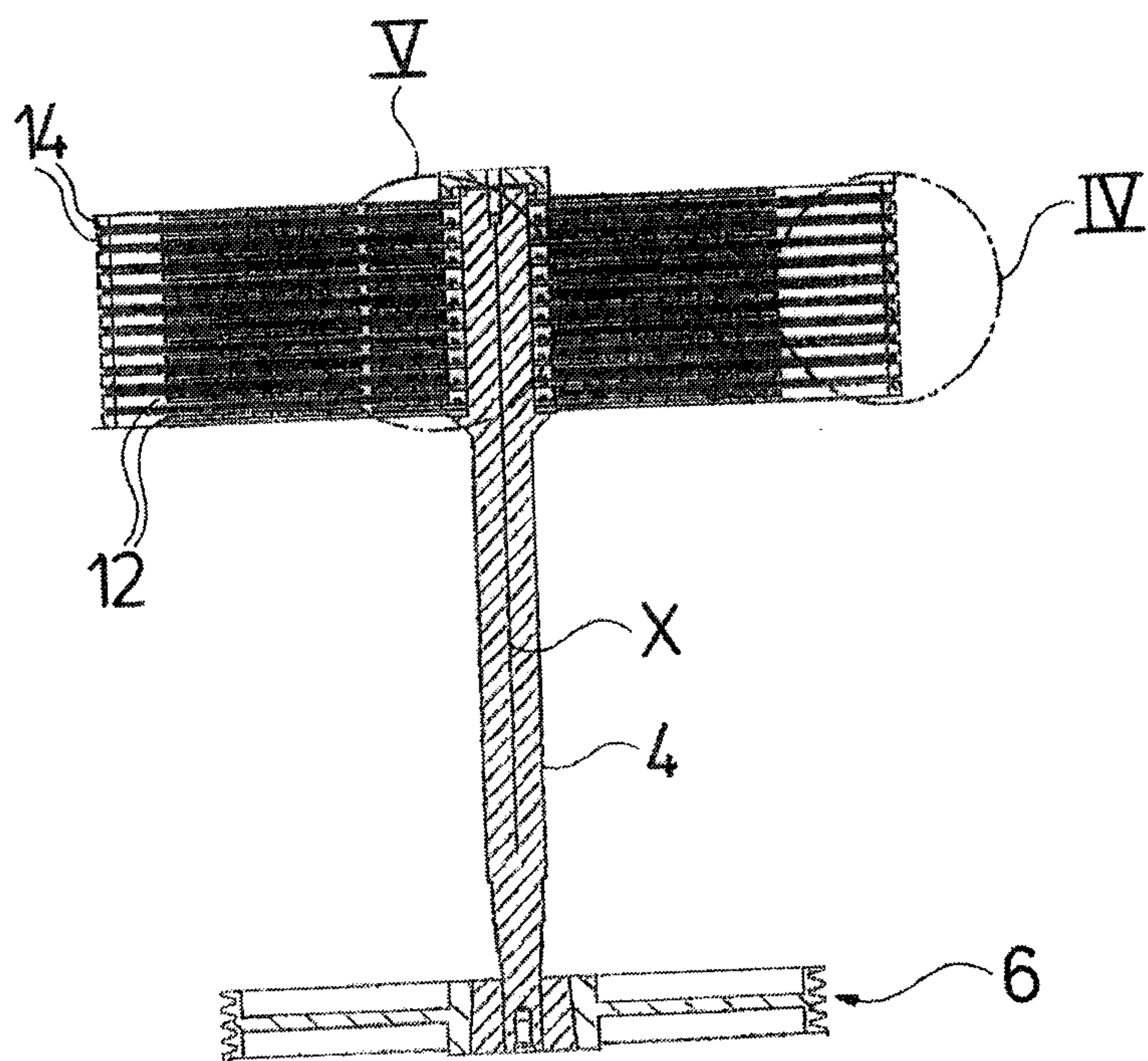

Fig.4

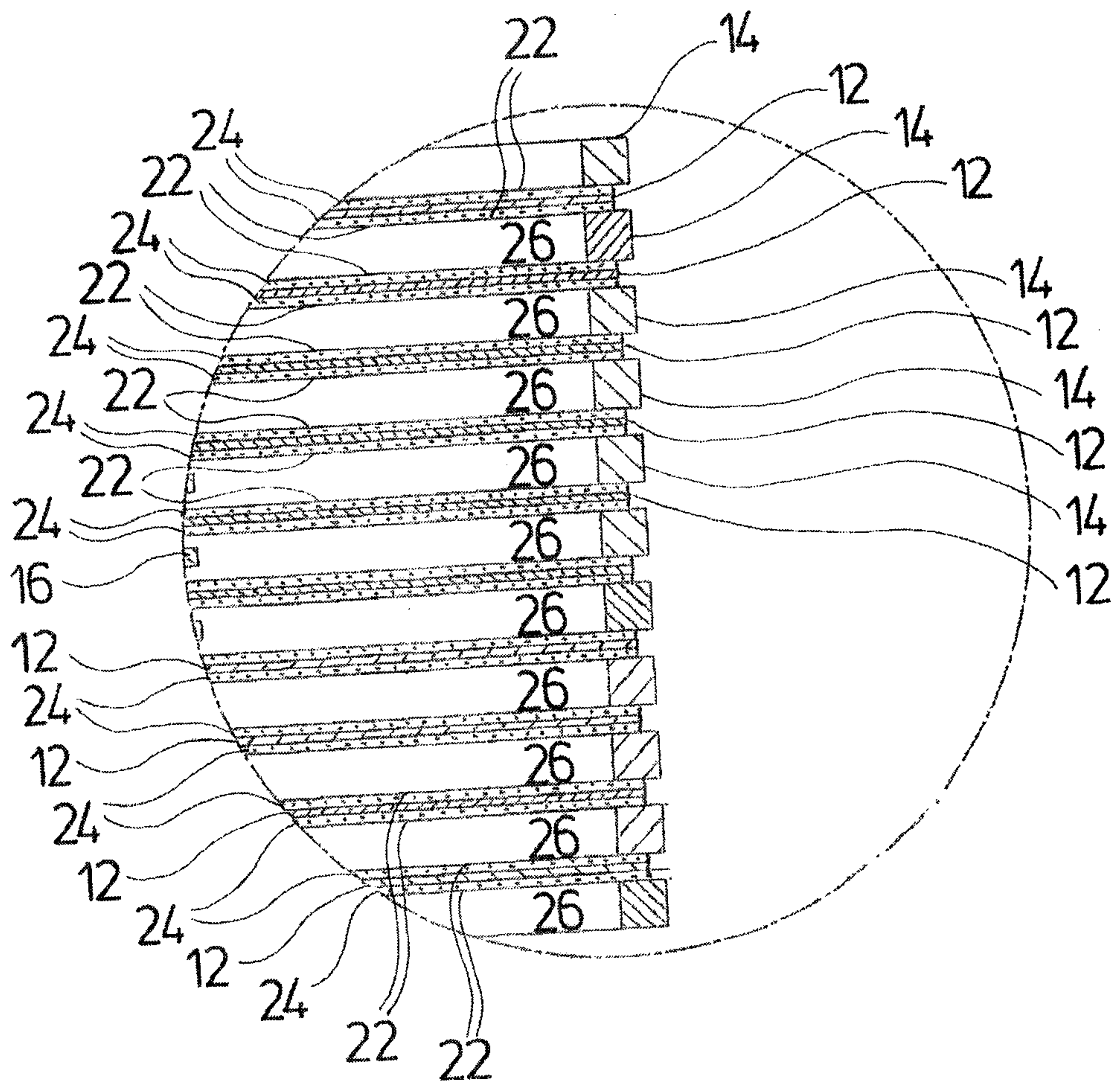

Fig.5

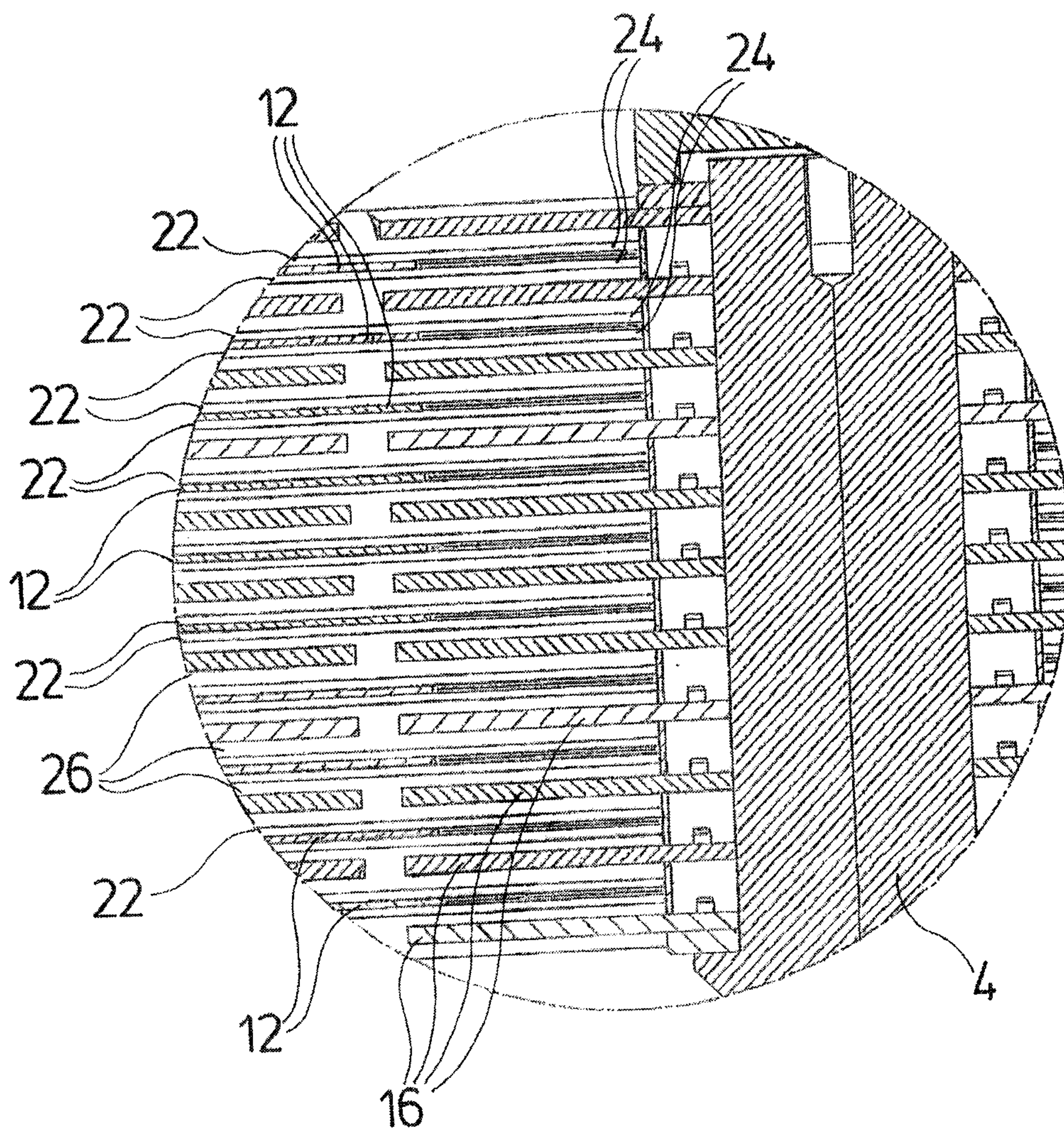

Fig.6

