

- [54] **PORTABLE ELECTRONIC PRECIPITATOR**
- [75] Inventor: **Teddy A. Duval**, Garland, Tex.
- [73] Assignee: **Texas Electronic Precipitator Co.**, Garland, Tex.
- [22] Filed: **Dec. 15, 1970**
- [21] Appl. No.: **98,429**
- [52] U.S. Cl. .... **55/104, 55/126, 55/129, 55/138, 55/139, 55/143, 55/151, 55/481**
- [51] Int. Cl. .... **B03c 3/66**
- [58] Field of Search ..... **55/104, 105, 106, 55/139, 136, 137, 138, 140, 141, 143, 145, 270, 274, 481**

Electro-Air Cleaner Company, Inc., Olivia & Sproul Streets, McKees Rocks, Pa. 4 pages, received in Patent Office Oct. 26, 1967.

*Primary Examiner*—Dennis E. Talbert, Jr.  
*Attorney*—Giles C. Clegg, Jr., Jack A. Kanz and Richard E. Bee

[56] **References Cited**  
**UNITED STATES PATENTS**

2,347,709	5/1944	Penney .....	55/145 X
2,449,681	9/1948	Wilson .....	55/104 X
2,469,231	5/1949	Klemperer .....	55/139 X
2,858,900	11/1958	Foley .....	55/112
2,979,158	4/1961	Vlier, Jr. ....	55/126 X
3,438,180	4/1969	Klovda .....	55/139 X
3,484,772	12/1969	Niewyk et al. ....	55/274 X

**OTHER PUBLICATIONS**

“Electro-Air Electronic Air Cleaners Slim Line units,”

[57] **ABSTRACT**

A two-stage type electrostatic precipitator mechanism is carried within a rectangular cabinet having an air intake at one end and an air outlet at the other. A blower mechanism is carried within the cabinet for moving air through the cabinet and past the ionizing wires and collecting plates of the precipitator mechanism. A power supply circuit provides high voltages for the ionizing wires and collecting plates and an indicator lamp is connected in circuit with such power supply circuit for providing an alarm signal when the collecting plates become too dirty. The spacing between the collecting plates and the value of the high voltage supplied thereto are of an unconventional nature and provide improved operating performance. The precipitator unit as a whole is constructed so that it can be operated in either a normal or an upside-down position.

**5 Claims, 7 Drawing Figures**

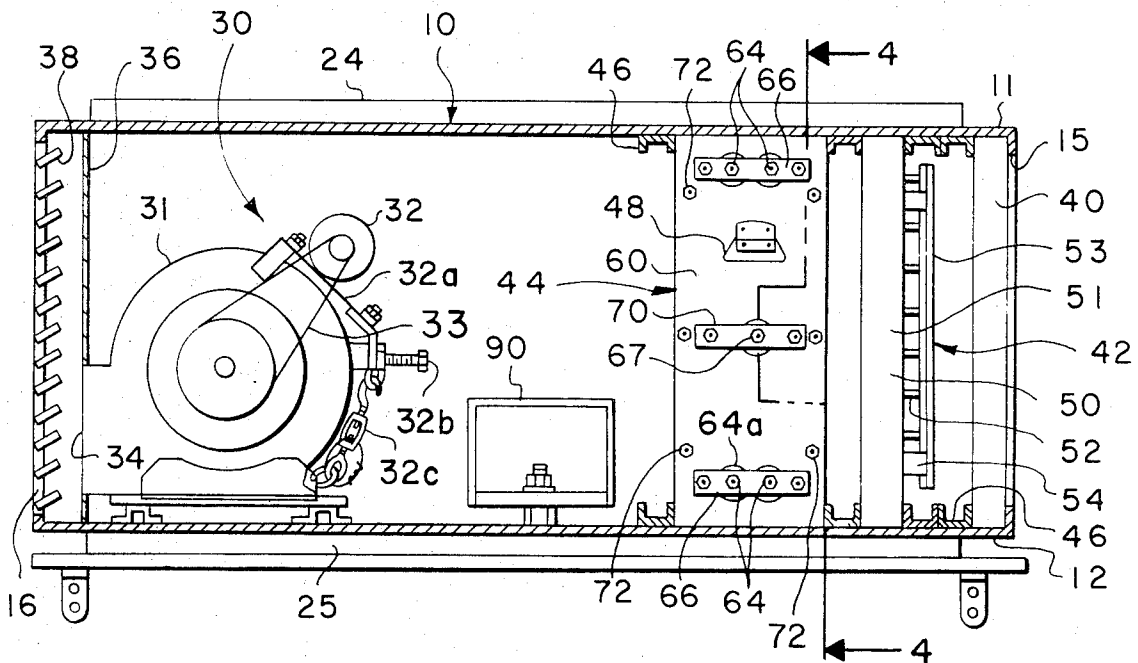

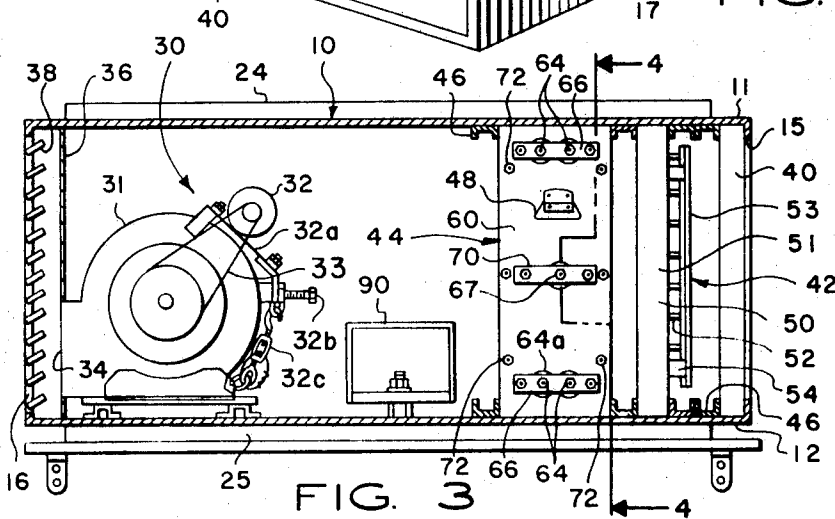
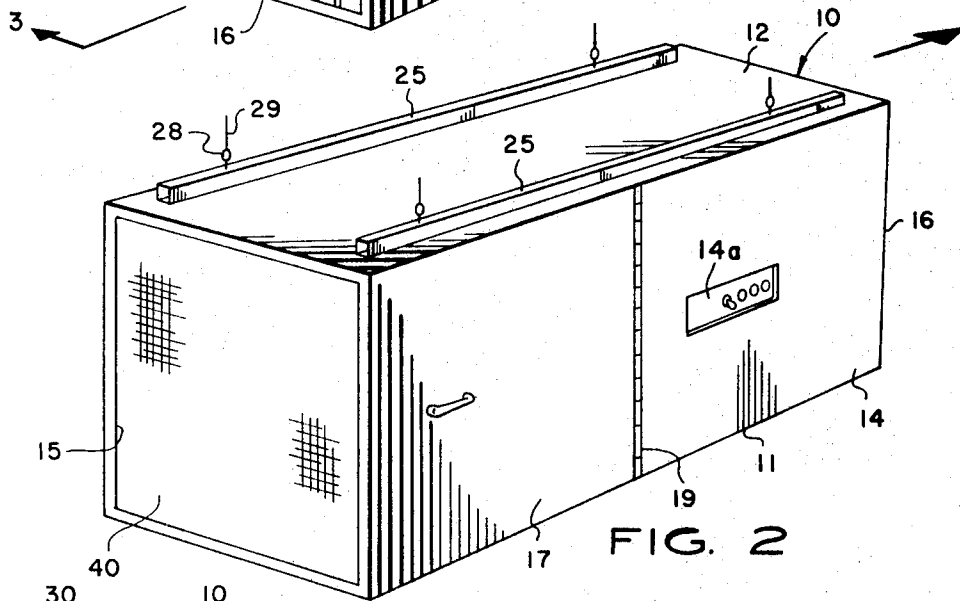
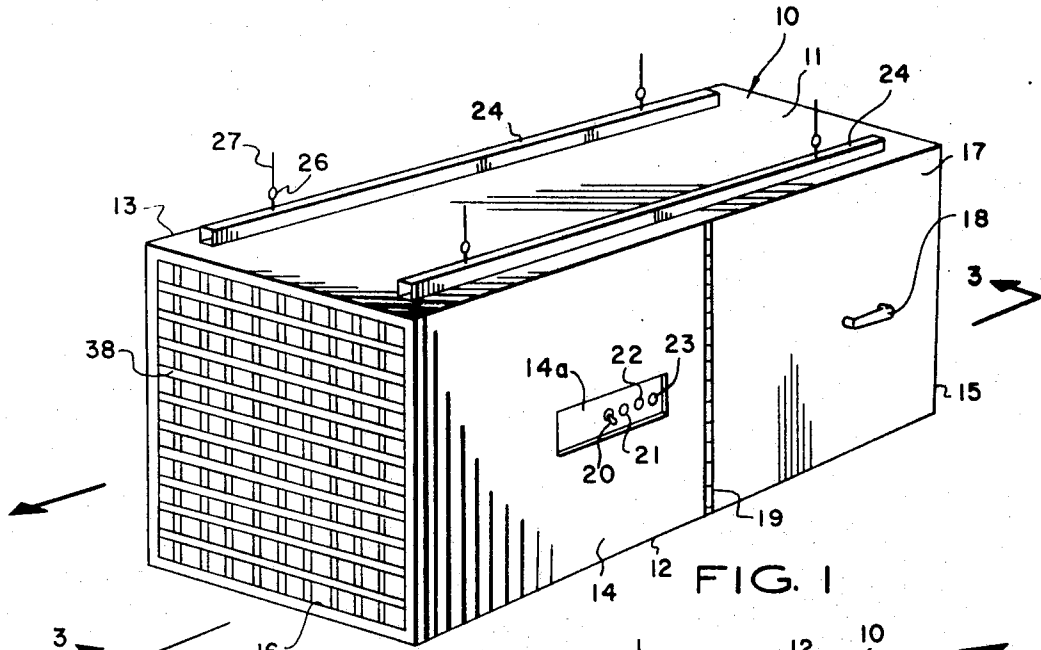

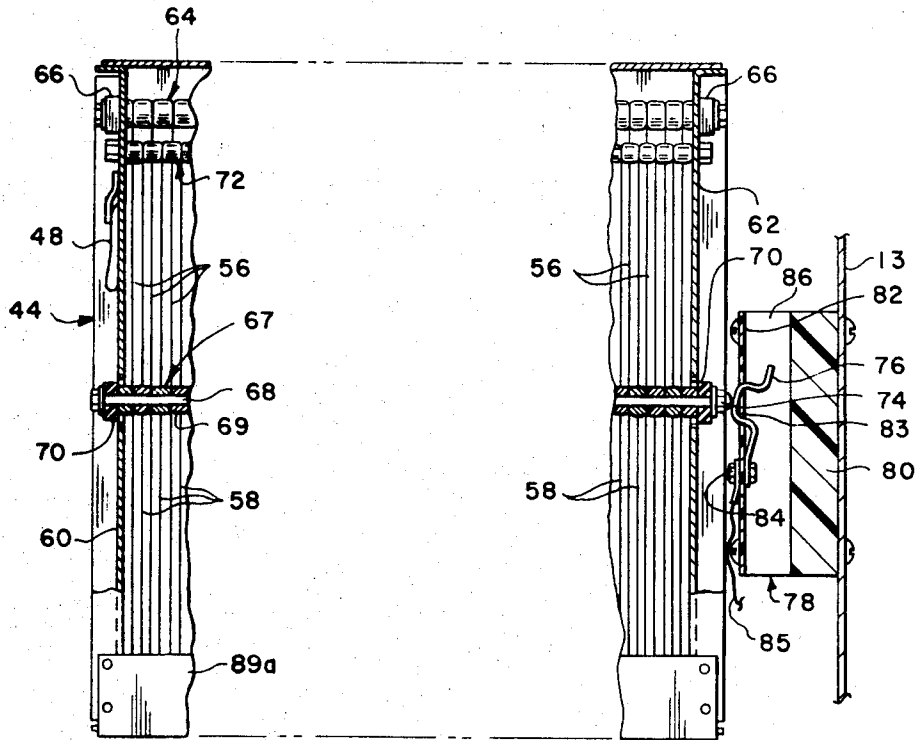

FIG. 4

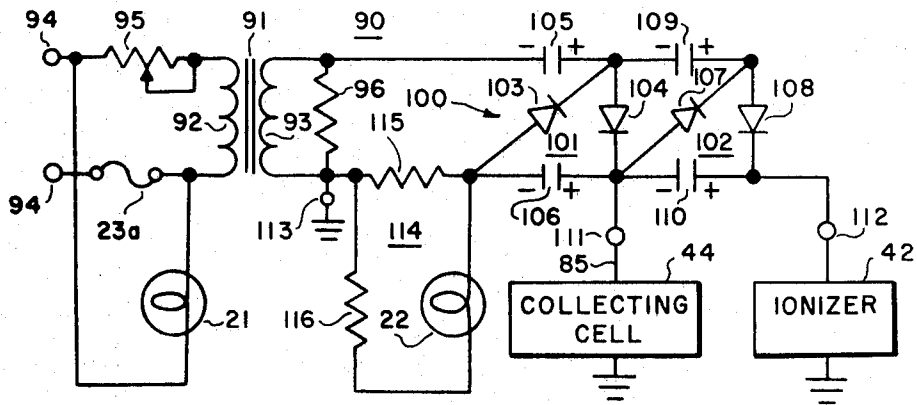

FIG. 6

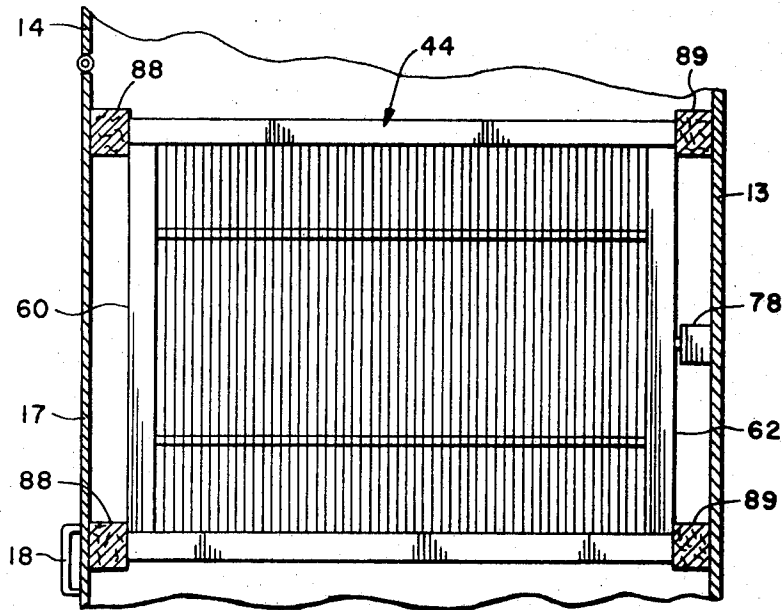

FIG. 5

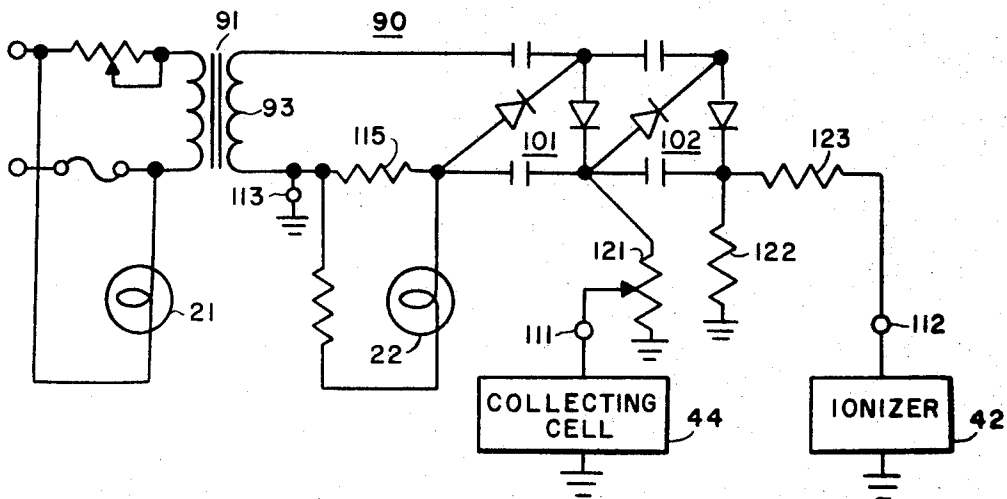

FIG. 7

## PORTABLE ELECTRONIC PRECIPITATOR

### BACKGROUND OF THE INVENTION

This invention relates to electronic precipitators and, particularly, to portable electronic precipitators for cleaning the air in an interior space frequented by human beings.

It has been heretofore proposed to use a compact portable electronic precipitation in a people-inhabited room or interior space for purposes of cleaning the air in the room. Such a precipitator is particularly useful for removing solids and liquid such as smoke, oil mist and the like from the air. The previously proposed precipitators, however, suffer from various limitations and disadvantages. For one thing, the operation of the precipitator causes the air-borne particles to be deposited on and adhere to the surfaces of the collecting plates therein. As the use continues, the particle layer or film become thicker and thicker, thus reducing the air space between the collecting plates. Eventually, the air gap between collecting plates becomes sufficiently small such that electrical arcing occurs between plates. Arcing reduces the voltage across the plate, substantially reducing the efficiency of the unit and increasing the amount of ozone produced. This can, of course, be prevented by periodic cleaning of the collecting plates. Unfortunately, however, there are many variables which enter into determining the length of time required for the particle deposit to build up to a dangerous thickness. Thus, it is difficult to know how often the collecting plates should be cleaned in order to maintain efficient operation.

Another problem with previously proposed portable type precipitators is that they tend to produce more ozone than is desired. If such ozone concentration should become very significant, it could have a toxic effect on the human inhabitants in the room. Also, the smell of such ozone may be disagreeable to some of the inhabitants.

A further problem with some previously proposed portable type precipitators is that their construction allows some of the room air to pass through the precipitator without passing between the collecting plates. This undesired blow-by reduces the overall efficiency of the precipitator.

It is an object of the invention, therefore, to provide a new and improved portable electronic precipitator which substantially overcomes one or more of the limitations of the portable precipitators heretofore proposed.

It is another object of the invention to provide a new and improved portable electronic precipitator which substantially avoids excessive ozone production and the like and in which an indication is provided if the collecting plates become excessively dirty.

For a better understanding of the present invention, together with other and further objects and features thereof, reference is had to the following description taken in connection with the accompanying drawings, the scope of the invention being pointed out in the appended claims.

### BRIEF DESCRIPTION OF THE DRAWINGS

Referring to the drawings:

FIG. 1 is a perspective view of a portable electronic precipitator constructed in accordance with the present invention;

FIG. 2 is a perspective view similar to FIG. 1 except that the precipitator unit is turned upside-down so that the direction of air flow is reversed;

FIG. 3 is an elevational view taken along section line 3—3 of FIG. 1 and showing the precipitator with the front panel removed;

FIG. 4 is a cross-sectional view taken along section line 4—4 of FIG. 3 and showing further details of the collecting cell;

FIG. 5 is a top view of the collecting cell used in the FIG. 1 precipitator unit;

FIG. 6 is an electrical circuit diagram for a first embodiment of a power supply unit carried within the FIG. 1 precipitator; and

FIG. 7 is a circuit diagram for a second embodiment of a power supply unit.

### DESCRIPTION OF THE ILLUSTRATED EMBODIMENT

Referring to FIG. 1, there is shown a portable electronic precipitator for cleaning the air in a room or other interior environment frequented by human beings. The precipitator includes a rectangular metal cabinet 10 having a top panel 11, a bottom panel 12, a back panel 13 and a front panel 14. The cabinet 10 also includes an air intake 15 located at the right hand end in FIG. 1 and an air outlet 16 located at the left hand end in FIG. 1. The front panel 14 includes a hinged door 17 having a handle 18, the door hinge being indicated at 19. The remainder of the front panel 14 is permanently secured to the top and bottom panels 11 and 12. An on-off switch 20, a pair of indicator lamps 21 and 22 and a fuse holder 23 are mounted on a panel plate 14a releasably secured to the non-door portion of the front panel 14.

FIG. 2 shows the precipitator cabinet 10 of FIG. 1 turned upside-down so that the top panel 11 is on the bottom and the bottom panel 12 is on the top. This reverses the direction of air flow, the air moving from left to right in FIG. 2. At the same time, the front panel 14 is still facing in the forwardly direction. During installation, the panel plate 14a is unfastened, rotated 180° and then refastened. This keeps the printed legends on plate 14a in a non-inverted condition for easier reading of same.

As indicated in FIG. 1, a first set of mounting members 24 is secured to the top panel 11, while, as indicated in FIG. 2, a second set of mounting members 25 is secured to the bottom panel 12. These mounting members 24 and 25 are in the form of hollow square-shaped metal channel members welded or bolted to the top and bottom panels 11 and 12. Various metal eyelets 26 may be screwed into the mounting members 24 for purposes of suspending the cabinet 10 from the ceiling of a room by way of wires 27. Similarly, when the upside-down position of FIG. 2 is desired, various eyelets 28 may be screwed into the bottom panel mounting members 25 for suspending the cabinet 10 by means of wires 29. Alternatively, the cabinet 10 may be set on top of a shelf (shown in FIG. 3) or some form of horizontally extending support brackets which extend outward from a wall of the room.

As will be seen, the various units, components and mechanisms located within the cabinet 10 are constructed so that the precipitator operates perfectly satisfactorily either with the top panel 11 on top and the bottom panel 12 on bottom or vice-versa. This upside-

down feature gives the user a greater degree of freedom in the manner of placement of the cabinet 10 in the room. In particular, the cabinet 10 can be mounted so that the air flow is from right to left or vice-versa, as desired, and yet the front panel 14 will still face in the same direction for purposes of allowing access to the service door 17 for enabling periodic replacement of the precipitator mechanism within the cabinet 10 by clean mechanisms. This is particularly important where it is desired to have the back panel 13 located against or near a wall of the room. In other words, the cabinet 10 can be mounted against a wall of the room and the user will still have a choice as to the direction of air flow.

Referring now to FIG. 3, there is shown a front elevational view of the precipitator unit of FIG. 1 with the front panel 14 (including door 17) removed. As seen in FIG. 3, there is carried within the cabinet 10 a blower unit 30 for moving air through the cabinet 10 from the intake 15 to the outlet 16. Blower unit 30 includes a squirrel cage type fan blade mechanism 31 and an electric motor 32 mounted thereon and coupled to the squirrel cage rotor by way of pulley belt 33. Motor 32 is mounted on a plate 32a, one end of which is pivotally pinned to the housing of fan 31 and the other end of which is supported by a tension adjustment screw 32b for adjusting the tension of pulley belt 33. An adjustable linkage 32c running to the base plate for the fan housing maintains the proper belt tension when the unit is operated in the inverted position of FIG. 2. The outlet opening 34 of the fan blade mechanism 31 is mounted in an exhaust port formed in an otherwise solid partition 36 which extends completely across the left-hand end of the cabinet 10 a short distance inside the cabinet outlet 16. A louver structure 38 is mounted in the air outlet 16 for covering the opening at the left-hand end of the precipitator and, at the same time, allowing the discharge of the cleaned air back into the room.

A mechanical air filter 40 is removably mounted immediately inside the cabinet intake opening 15. Filter 40 may be of either the glass wool or metal excelsior type and serves to prevent larger size solid particles or materials from entering the interior of the cabinet 10. Filter 40 also serves to impart a pressure drop across the inlet so that a more uniform velocity distribution is achieved.

Also carried within the cabinet 10 is a precipitator mechanism located in the air flow path for removing the smaller airborne particles (tobacco smoke, oil mist, etc.) from the air as it passes through the cabinet 10. In the present embodiment, the precipitator mechanism is a two stage type of electrostatic precipitator and, as such, includes an ionizer unit 42 and a collecting cell unit 44 located downstream of the ionizer unit 42. Each of units 42 and 44 extends across the width and height of the interior of the cabinet 10 and each is removably mounted within the cabinet 10 by means of slideways formed by channels 46 which are secured to the top and bottom panels 11 and 12 and which run horizontally from the front to the back of the cabinet 10. Thus, the ionizer and collecting cell units 42 and 44 (as well as the filter 40) can be removed from the cabinet 10 by opening the service door 17 and pulling them in the forwardly direction. Collecting cell unit 44 is provided with a handle 48 for facilitating its removal.

The ionizer unit 40 includes a four-sided frame-like metal chassis 50 having a vertically spaced series of horizontal metal plates or fins (not shown) which extend from the front panel end 51 to the rear panel end (not visible) of the chassis 50. Located intermediate these horizontal fins are horizontally-extending ionizer wires (not visible) which are strung between the ends of inwardly extending metal fingers 52 which form parts of and extend toward the left from a pair of side-located vertically running channel members 53 (the rearward one of which is hidden by the forward one). The channel members 53 are spaced from the chassis 50 by means of electrical insulators 54. The application of a relatively high positive voltage to the ionizer wires causes a corona discharge between such wires and the grounded fins, the latter being grounded by way of the ionizer chassis 50 and the cabinet 10. The gaseous ionization thus produced by such corona discharge serves to charge the suspended airborne particles as they move through the ionizer unit 40.

FIG. 4 is a cross-sectional view taken along line 4-4 of FIG. 3 and shows in greater detail the construction of the collecting cell unit 44. Such collecting cell unit 44 includes a group of spaced electrically conductive elements located in the air flow path for removing from the air the airborne particles charged by the ionizer unit 40. As seen in FIG. 4, these electrically conductive elements comprise two interleaved sets of spaced parallel plates, the plates in the first set being designated by reference numeral 56 and the plates in the second set being designated by reference numeral 58. Plates 56 will be referred to as the positive plates, while plates 58 will be referred to as the negative plates. When in place in cabinet 10, the positive plates 56 are connected to a source of high positive voltage, while the negative plates 58 are grounded to the cabinet. In FIG. 4, the plates 56 and 58 are being viewed in an edgewise manner, such plates being supported between and extending parallel to a pair of end plates 60 and 62, the former of which is seen in elevation in FIG. 3. Thus, the collecting cell plates 56 and 58 have their larger surfaces disposed in line with the direction of air flow.

The positive plates 56 are supported near their four corners by four spacer assemblies 64 which pass through end plate holes 64a (FIG. 3) and are bolted to insulator blocks 66 which are, in turn, bolted to the end plates 60 and 62. A further positive plate spacer assembly 67 extends through the middle of the collecting cell plates. As seen in FIG. 4, such center spacer assembly 67 comprises an elongated metal bolt or shaft 68 having a series of metal spacer rings 69 mounted thereon. Shaft 68 passes through small, tight-fitting holes in the positive plates 56. Spacer rings 69 clamp the plates 56 in position and maintain the desired spacing therebetween. Such rings 69 pass through holes in the negative plates 58 and end plates 60 and 62 of larger diameter than the rings 69 such that there is no electrical contact therebetween. The ends of spacer shaft 68 are bolted to insulator blocks 70 which are, in turn, bolted to the end plates 60 and 62. The construction is such that all of the positive plates 56 are in electrical contact with the center shaft 68 and the plates 56 and shaft 68 are electrically insulated from both the negative plates 58 and the end plates 60 and 62.

Negative plates 58 are supported in a somewhat similar manner by means of spacer assemblies 72 located near the four corners thereof. The metal center shafts

of these spacer assemblies 72 are bolted directly to the end plates 60 and 62 for purposes of grounding the negative plates 58 to the cabinet 10. The negative plates 58 are somewhat longer in the direction of air flow than positive plates 56 so that spacer assemblies 72 may be located clear of the positive plates 56.

Electrical contact is made with the positive plates 56 by means of a nut 74 on the rearward end of the center spacer shaft 68. When the collecting cell unit 44 is in place in the cabinet 10, this nut 74 engages a contact spring 76 in a contact assembly 78 mounted on the inner wall of the back panel 13 of the cabinet 10. Contact assembly 78 includes an insulator block 80 which is bolted to the back panel 13 and a support plate 82 which is bolted to the front side of the insulator block 80. Contact spring 76 is a strip of resilient metal material bent to provide a forwardly extending hump portion which extends through an opening 83 in the support plate 82. The lower end of contact spring 76 is secured to the plate 82 by screws 84. The lugged end of an insulated conductor wire 85 is looped over and makes contact with one of the screws 84. Conductor wire 85 runs to an electrical power supply unit to be considered hereinafter. A vertical slot or channel 86 is cut into the insulator block 80 for accommodating the contact spring 76.

FIG. 5 shows a top view of the collecting cell unit 44. A pair of vertically-extending resilient sealing strips 88 are secured to the inside of door 17 for engaging end plate 60 of collecting cell unit 44, while a second pair of vertically-extending resilient sealing strips 89 are secured to the inside of back panel 13 for engaging the other end plate 62 of unit 44. These strips 88 and 89 may be made of felt or other suitable material and serve to prevent air flow on the exterior sides of the end plates 60 and 62. Upper and lower baffle plates 89a (only the lower of which is visible in FIG. 4) prevent air flow past the collecting cell unit 44 in regions above and below the effective areas of collecting plates 56 and 58. Thus, undesired blow-by is prevented and the efficiency of the precipitator unit is increased.

Referring to FIG. 6 there is shown the circuit diagram for a power supply unit 90 carried within the cabinet 10 for producing the desired electrical potential differences between the conductive elements in the ionizer unit 42 and the collecting cell unit 44. Physically, the power supply unit 90 is secured to the bottom panel 12 at the location indicated in FIG. 3. As seen in FIG. 6, the power supply unit 90 includes a voltage step-up transformer 91 having a primary winding 92 and a secondary winding 93. Primary winding 92 is coupled to a pair of terminals 94 which are adapted to be connected to a source of alternating-current power such as, for example, an alternating-current power line. A rheostat 95 is connected between one of the terminals 94 and one end of the primary winding 92. A fuse 23a (located in fuse holder 23) is connected between the other terminal 94 and one end of the primary winding 92. A red-colored indicator lamp 21 is connected in parallel with the rheostat 95 and a secondary winding 92 for indicating that the high-voltage power supply unit 90 is being energized.

Connected to the secondary winding 93 of the step-up transformer 91 is a rectifier circuit 100 of the voltage quadrupler type. A bleeder resistor 96 is also connected across secondary winding 93 to stabilize the loading on transformer 91 and thus the voltage across

secondary 93. Quadrupler circuit 100 includes a first voltage doubler 101 connected in cascade with a second voltage doubler 102. Voltage doubler 101 includes a pair of semiconductor diodes 103 and 104 and a pair of capacitors 105 and 106. The second voltage doubler 102 includes a pair of semiconductor diodes 107 and 108 and a pair of capacitors 109 and 110. High-voltage output terminals for the quadrupler circuit 100 are indicated at 111 and 112. A common ground return terminal is indicated at 113, such terminal 113 being grounded to the cabinet 10.

The operation of the quadrupler circuit 100, which is well known in the electrical arts, is such that there is produced between the first high-voltage output terminal 111 and the ground terminal 113 a direct-current voltage difference of approximately (slightly less than) twice the peak value of one-half cycle of the alternating-current voltage appearing across the secondary winding 93 of the step-up transformer 91. There is produced between the second high-voltage output terminal 112 and the ground terminal 113 a direct-current voltage difference equal to (slightly less than) twice the voltage difference between the first high-voltage terminal 111 and the ground terminal 113. The voltages at terminals 111 and 112 are of positive polarity. In the present embodiment, the turns ratio of the step-up transformer 91 is constructed so that, with an input voltage of 90 volts at terminals 94, the magnitude of the positive direct-current voltage appearing at the first high-voltage terminal is approximately 4.4 kilovolts, while the magnitude of the positive direct-current voltage appearing at the second high-voltage terminal 112 is approximately 8.4 kilovolts, both being measured with respect to the ground terminal 113.

As indicated in FIG. 6, the first or lower-value high-voltage terminal 111 is connected to the positive plates 56 in the collecting cell 44 by way of the conductor wire 85 and the contact assembly 78 previously considered. The second or higher-value high-voltage output terminal 112, on the other hand, is connected to the ionizing wires in the ionizer unit 42. An important feature of this FIG. 6 power supply embodiment is that the circuit is constructed so that the ionizer 42 cannot operate unless the collecting cell unit 44 is also operating. This results from the fact that units 42 and 44 are connected directly to the voltage doublers 101 and 102 and from the further fact that the second doubler 102 cannot function unless the first doubler 101 is operating. This interlock feature prevents the undesired escape of ionized particles into the room in the event the collecting cell unit 44 should become inoperative.

Connected in circuit with the power supply means represented by step-up transformer 91 and rectifier circuit 100 is indicator means 114 for providing an alarm signal when the electrically conductive plates 56 and 58 in the collecting cell unit 44 become too dirty. This indicator means includes a current-sensing element represented by a current-sensing resistor 115 connected in series with the transformer secondary winding 93 and the rectifier circuit 100 for sensing the leakage current passing between the collecting cell plates 56 and 58. The indicator means further includes an amber-colored indicator lamp 22 and a current-limiting resistor 116 connected in series across the current-sensing resistor 115. When the leakage current flowing between the positive and negative collecting plates 56 and 58 indicates that the build up of the particle film

on such plates has reached the critical level, the voltage drop across the current-sensing resistor 115 reaches a value sufficient to cause a lighting of the indicator lamp 22. This provides a visual alarm signal which indicates that the collecting cell plates 56 and 58 have become too dirty.

The collecting cell unit 44 is constructed so that the spacing between neighboring ones of the positive and negative collecting cell plates 56 and 58 is not more than 0.205 inches. The high-voltage power supply unit 90 is constructed so that the voltage difference or potential difference between negative and positive plates 56 and 58 is less than 5,000 volts. This collecting cell spacing and collecting cell potential difference are significantly less than those used in conventional precipitator apparatus. It has been found, however, that such reduced spacing and voltage parameters provide an improved air cleaning action while, at the same time, decreasing the amount of ozone produced. The desired spacing factor between neighboring collector cell plates is obtained by the proper choice of lateral dimensions for the various spacer rings used on the spacer assemblies 64, 67 and 72. The desired potential difference value is obtained primarily by proper proportioning of the turn ratio in the step-up transformer 91. Rheostat 95 enables some adjustment of the high-voltage output values but is included primarily for purposes of compensating for differences in alternating-current power line voltages at different places of use.

FIG. 7 shows a modified form of construction for the power supply unit 90. In FIG. 7, the bleeder resistor 96 of FIG. 6 is omitted. In place thereof, bleeder resistors 121 and 122 are connected between the output terminals of voltage doublers 101 and 102, respectively, and chassis ground. Resistor 121 is of the potentiometer type and collecting cell 44 is connected to the sliding tap thereof. Ionizer unit 42 is connected to the output terminal of the second doubler 102 by way of a current limiting resistor 123. The sliding tap on resistor 121 enables proper adjustment of the collecting cell voltage relative to the ionizer voltage. The FIG. 7 circuit has the advantage that less heat is generated by the bleeder resistors but suffers from the disadvantage that the interlock feature of the FIG. 6 circuit is not as complete.

Cabinet 10 and service door 17 are constructed in an air-tight manner such that when the door 17 is closed, air can enter or leave the cabinet 10 only by way of intake 15 and outlet 16. The latching mechanism associated with door handle 18 is provided with a safety interlock mechanism (not shown) such that the high-voltage power supply 90 is automatically turned off whenever the service door 17 is open. Also, the power cord and plug used for connecting the unit to the power line is of the three-wire and three-prong type with one wire and prong being used to ground the cabinet 10.

In use, the blower unit 30 serves to cause air in the room to be drawn into the intake 15, to pass through the cabinet 10 and to be discharged from the outlet 16. As the particle-laden air passes through the corona discharge produced by the ionizer unit 42, the airborne particles acquire an electrical charge. Thereafter, as such charged particles move through the collecting cell unit 44, they are electrically attracted to the plates 56 and 58 and deposit themselves thereon. As this deposit or film on the collecting plates 56 and 58 builds up, the leakage current between plates 56 and 58 increases. When the magnitude of such leakage current reaches

the dangerous level such that arcing may begin to occur, the voltage drop across the current-sensing resistor 115 becomes sufficient to light the amber-colored indicator lamp 22. This visual indication warns the user that the collecting plates 56 and 58 have become too dirty and need cleaning.

While there has been described what is at present considered to be a preferred embodiment of the invention, it will be obvious to those skilled in the art that various changes and modifications may be made therein without departing from the invention, and it is, therefore, intended to cover all such changes and modifications as fall within the true spirit and scope of the invention.

I claim

1. A portable electronic precipitator for cleaning the air in a room or other relatively enclosed environment frequented by human beings comprising:

a rectangular cabinet having top, bottom, front and back panels and an air intake at one end and an air outlet at the opposite end;

blower means carried within the cabinet for moving air from the intake to the outlet;

precipitator means carried within the cabinet and including a group of spaced electrically conductive elements located in the air flow path for removing airborne particles from the air; and,

power supply means carried within the cabinet for producing a substantial electrical potential difference between different ones of the conductive elements;

the blower means, precipitator means and power supply means being mounted within the cabinet so that the precipitator can be operated either with the top panel on top and the bottom panel on bottom or vice versa;

first mounting means secured to the top panel and second mounting means secured to the bottom panel of the cabinet so that the cabinet may be mounted either with the top panel up and the bottom panel down or vice versa;

indicator means connected in the circuit with the power supply means for providing an alarm signal when the conductive elements become too dirty for desired operational efficiency;

said front panel including a hinged door for providing access to the interior of the unit, the direction in which said front panel faces being capable of being made constant as the direction of air flow is reversed by reversing the one said mounting means used for mounting said precipitator; and

a panel plate mounting the controls for said precipitator and releasably secured to a fixed portion of said front panel whereby as the mounting is changed from one of said mounting means to the other, the panel plate means can be rotated 180° to maintain the printed legends on the plate in a non inverted condition.

2. A portable electronic percipitator in accordance with claim 1 wherein the indicator means is constructed and connected to sense the leakage current passing between the electrically conductive elements.

3. A portable electronic precipitator in accordance with claim 1 wherein the power supply means includes a step-up transformer and rectifier circuit means coupled to the secondary thereof for supplying a relatively large unidirectional voltage to some of the electrically



9

10

conductive elements and wherein the indicator means includes a current sensing means connected in series with the transformer secondary winding and the rectifier circuit means.

4. A portable electronic precipitator in accordance with claim 3 wherein the current sensing means includes an indicator lamp for providing a visual alarm signal when the electrically conductive elements become too dirty.

5. A portable electronic precipitator in accordance with claim 3 wherein the current sensing means includes a current sensing resistor connected in series with the transformer secondary winding and the rectifier circuit means and further includes an indicator lamp and current limiting resistor connected in series across the current sensing resistor.

\* \* \* \* \*

10

15

20

25

30

35

40

45

50

55

60

65