

(19) World Intellectual Property Organization
International Bureau



(43) International Publication Date
3 January 2002 (03.01.2002)

PCT

(10) International Publication Number
WO 02/01391 A2

- (51) International Patent Classification⁷: **G06F 17/00**
- (21) International Application Number: PCT/US01/20176
- (22) International Filing Date: 25 June 2001 (25.06.2001)
- (25) Filing Language: English
- (26) Publication Language: English
- (30) Priority Data:
60/213,484 23 June 2000 (23.06.2000) US
- (71) Applicant (for all designated States except US): **ECOM-SYSTEMS, INC.** [US/US]; 378 Interstate Court, Sarasota, FL 34240 (US).
- (74) Agents: **REMENICK, James** et al.; Intellectual Property Department, Brobeck, Phleger & Harrison LLP, 1333 H Street, N.W., Suite 800, Washington, DC (US).
- (81) Designated States (national): AE, AG, AL, AM, AT, AU, AZ, BA, BB, BG, BR, BY, BZ, CA, CH, CN, CR, CU, CZ, DE, DK, DM, DZ, EC, EE, ES, FI, GB, GD, GE, GH, GM, HR, HU, ID, IL, IN, IS, JP, KE, KG, KP, KR, KZ, LC, LK, LR, LS, LT, LU, LV, MA, MD, MG, MK, MN, MW, MX, MZ, NO, NZ, PL, PT, RO, RU, SD, SE, SG, SI, SK, SL, TJ, TM, TR, TT, TZ, UA, UG, US, UZ, VN, YU, ZA, ZW.
- (84) Designated States (regional): ARIPO patent (GH, GM, KE, LS, MW, MZ, SD, SL, SZ, TZ, UG, ZW), Eurasian patent (AM, AZ, BY, KG, KZ, MD, RU, TJ, TM), European patent (AT, BE, CH, CY, DE, DK, ES, FI, FR, GB, GR, IE, IT, LU, MC, NL, PT, SE, TR), OAPI patent (BF, BJ, CF, CG, CI, CM, GA, GN, GW, ML, MR, NE, SN, TD, TG).

- (72) Inventors; and
- (75) Inventors/Applicants (for US only): **EVANS, Jon, C.** [US/US]; 1337 Reserve Drive, Venice, FL 34292 (US). **EVANS, James, M.** [US/US]; 1305 Reserve Drive, Venice, FL 34292 (US). **GOULD, Jon, K.** [US/US]; 8401 Boleyn Road, Sarasota, FL 34240 (US).

Published:
— without international search report and to be republished upon receipt of that report

For two-letter codes and other abbreviations, refer to the "Guidance Notes on Codes and Abbreviations" appearing at the beginning of each regular issue of the PCT Gazette.

(54) Title: SYSTEM AND METHOD FOR COMPUTER-CREATED ADVERTISEMENTS

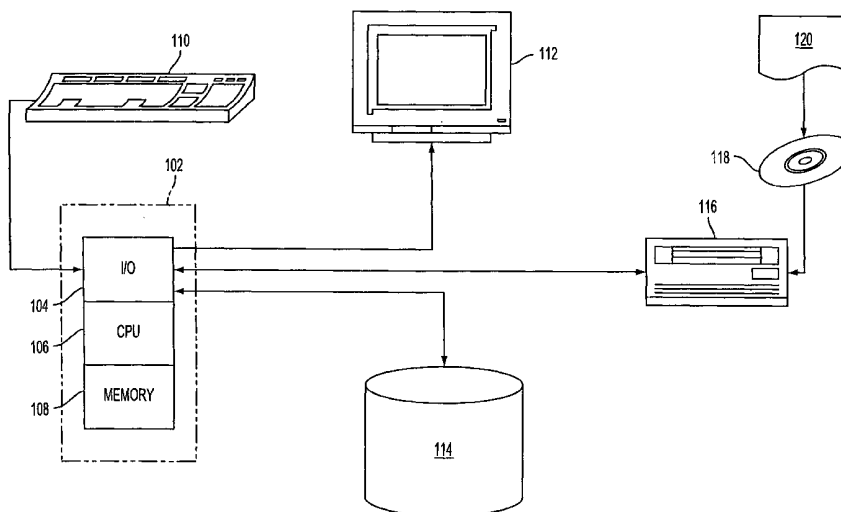

(57) Abstract: The invention relates to a computerized method for a user to create an advertisement by displaying a plurality of advertising formats for selection by a user; displaying a template corresponding to a selected advertising format; displaying a plurality of product references for selection by the user; displaying on the template a selected product reference to create a proposed advertisement; and creating a preview of the proposed advertisement, all of which may be implemented using the Internet. The invention further relates to a computerized system for creating an advertisement that comprises a template database for storing advertising formats; a product database for storing product references; and a computer to access the databases. Preferably, the user has a network interface such as Internet access that permits access via a remote location, software to permit a user to specify specifications such as quantity, printing information, ship date, paper type, pricing information, and payment information, and may be configured to receive images and text for new products.



WO 02/01391 A2

SYSTEM AND METHOD FOR COMPUTER-CREATED ADVERTISEMENTS

Reference to Related Applications

This application claims priority to U.S. provisional application, entitled
5 “Internet Advertising Design Build Model,” assigned serial number 60/213,484,
filed June 23, 2000, which is specifically and entirely incorporated by reference.

Background of the Invention

1. Field of the Invention

This invention relates to business models, methods and systems for
10 generating advertising materials useful for all forms of advertisement. More
particularly, this invention relates to computerized systems and methods for creating
advertisements.

2. Description of the Background

Conventional business methods for creating advertising require that written
15 materials and other documentation be provided by a customer (which we will refer
to herein as the user) to third party graphic artists who design the layout. The
customer must wait to receive a hard-copy proof from the artists, and then, after
reviewing and revising the proof, resend the proof to the artists for redesign. When
the proof is finally approved, the information must be delivered to a commercial
20 printer to produce the advertisements in their final form. At each stage of the
process, there can be substantial delays. After one or more redesigns, the customer
must wait for a final proof and then, once approved, wait for the final product to be
produced.

The conventional process is time consuming and inefficient, and can also be
25 very expensive relative to the cost of services that can be provided by the present
invention. For example, a customer must employ the services of a graphic artist,
which can add significant cost to the process. Moreover, the inclusion of a graphic
artist into the process requires additional time and communications between the
artist and the customer. Each time the work-in-process is transferred between
30 parties (for example, from the graphic artist to the customer, from the customer to
the graphic artist, and from the graphic artist to the printer), the work-in-process
must enter the queue of the recipient, which may add uncontrollable delays, not to

- 2 -

mention the time associated with the logistics of transferring materials. Accordingly, there is a need for an improved system that is less time consuming and less costly.

Summary of the Invention

5 The present invention relates to methods and systems for creating advertisements. The present invention uses computers and software to create efficiencies in designing and printing advertisements. The present invention also contemplates the use of the Internet to streamline the processes.

10 Disclosed herein is a computerized method for a user to create an advertisement, comprising the steps: displaying on a computer a plurality of advertising formats for selection by the user; displaying on the computer, in response to selection by the user, a template that corresponds to a selected one or more of the plurality of advertising formats; displaying on the computer a plurality of product references for selection by the user; displaying on the template at least
15 one selected product reference to create a proposed advertisement; and creating a preview of the proposed advertisement. The method may also involve submitting specifications to a remote site and printing advertisements in accordance with the specifications. Remote sites are preferably commercial printers, but may also be printers in another office, at another location or in a different country.

20 Also disclosed is an Internet-based method for a user to create an advertisement, comprising the steps: accessing a web site through a computer; displaying on the computer a plurality of advertising formats for selection by the user; displaying on the computer, in response to selection by the user, a template that corresponds to a selected one or more of the plurality of advertising formats;
25 displaying on the computer a plurality of product references for selection by the user; displaying on the template at least one selected product reference to create a proposed advertisement; submitting to a remote site, via the internet, electronic files of the proposed advertisement, specifications for the proposed advertisement, the specifications including at least one of a quantity, a paper size, printing
30 specifications, drop shipping information, and a payment method; creating, at the

remote site, a preview of the proposed advertisement which may be a hard-copy proof or an electronic or other preview; making the preview available to the user for review; and printing, in accordance with set printing specifications, advertisements that correspond to the proposed advertisements. The method may also provide the user with the ability to enter information concerning custom product references, such that the custom product references may be displayed on the template along with product references selected from the displayed plurality of product references.

A computerized system for creating an advertisement is also disclosed. The system comprises: a template database for storing a plurality of advertising formats; a product database for storing a plurality of product references; a computer that has access to the template database and the product database. The computer accesses software that is capable of incorporating: a template selector for selecting at least one template from the template database; a product selector for selecting at least one product reference from the product database, each of the at least one product reference including at least one of an image and text; and a design interface for controlling the placement of a selected product reference on a selected template in order to create a proposed advertisement. The computer may also have a network interface (such as an interface to the Internet) that permits access to the computer via a remote location, so that a user may access the computer in order to create a proposed advertisement. The computer may also include software to create a specifications interface for inputting specifications (for example, quantity, printing information, shipping information and destination, pricing information, paper type, and payment information) for the advertisement.

Also disclosed is a computerized system for creating an advertisement, comprising: a template database for storing a plurality of advertising formats; a product database for storing a plurality of product references; and a computer that has access to the template database and the product database. The computer accesses software that is capable of incorporating: a template selector for selecting at least one template from the template database; a product input interface for adding new product references to the template database; a product selector for selecting at

least one product reference from the product database, each of the at least one product reference including at least one of an image and text; and a design interface for controlling the placement of a selected product reference on a selected template in order to create a proposed advertisement. The computer is also configured to include a network interface that permits access to the computer via a computer network connection such as, for example, an Internet or other broadband-based connection, a modem, a networked computer, or combinations thereof so that a user may access the computer to create a proposed advertisement. The system may also include an input for receiving an image (for example, from a digital camera) and textual information concerning new products, and a data marker for linking the digital data and the image.

An Internet-based method for a user to create an advertisement is also disclosed. The method comprises: accessing a web site through a computer, the web site being hosted on a host computer, and the host computer having access to a first database of advertising formats and a second database of product references; accessing the first database to identify a plurality of advertising formats; displaying on the computer the plurality of advertising formats for selection by the user; displaying on the computer, in response to selection by the user, a template that corresponds to a selected one or more of the plurality of advertising formats; accessing the second database to identify a plurality of product references; displaying on the computer the plurality of product references for selection by the user; displaying on the template at least one selected product reference to create a proposed advertisement; submitting to a remote site, via the Internet, electronic files of the proposed advertisement, specifications for the proposed advertisement, the specifications and final files that constitute the proposed advertisement including at least one of a quantity, printing specifications, a ship date, a paper type, and a payment method; creating, at the remote site, a preview of the proposed advertisement (e.g. hard-copy proof, electronic preview, printer's proof); and printing, in accordance with the printing specifications, shipping and destination information, pricing and payment information, advertisements that correspond to the

- 5 -

proposed advertisements. The method may also involve displaying on the computer a menu such as, for example, a drop-down or pop-up menu, that permits new custom product references to be entered into the second database.

Also disclosed are a method and system whereby a user operates a computer
5 to create an advertisement. This method comprises the steps: selecting an
advertising format from a plurality of advertising formats; displaying a template that
corresponds to a selected advertising format, which template includes a plurality of
advertising areas; selecting a product reference, which product reference comprises
at least one of an image and text; and importing the selected product reference onto
10 an advertising area to create an advertisement. Preferably, the advertising area is
configured to automatically format the selected product reference to fit within
physical dimensions of the advertising area.

A method and system for creating an advertisement are also disclosed. This
method comprises: selecting an advertising format; displaying a template that
15 corresponds to a selected advertising format, which template includes a plurality of
advertising areas; selecting a plurality of product references; specifying a rule of
priority for laying out the plurality of product references onto the plurality of
advertising areas; and generating an advertisement whereby the plurality of product
references are placed onto the plurality of advertising areas in accordance with the
20 rule of priority.

The present invention overcomes the problems and disadvantages associated
with conventional methods and systems including electronic systems, and provides
new business methods and systems whereby a user can access host computer or
server (for example, by way of a web site on the Internet), and quickly and
25 efficiently create customized advertising materials.

Other embodiments and advantages of the invention are set forth in part in
the description which follows, and in part, will be obvious from this description, or
may be learned from the practice of the invention.

Brief Description of the Drawings

30 Figure 1 depicts a general purpose computer system.

Figure 2 illustrates a schematic of one embodiment of one configuration of the invention.

Figure 3 illustrates a schematic of one embodiment of one process of the invention.

5 Figure 4 illustrates a template for selection of a product by vendor, brand or category.

Figure 5 illustrates available product reference options for the particular product selected from Figure 4.

Figure 6 illustrates a selection of one product reference option from Figure 5.

10 Figure 7 illustrates incorporation of the product reference selected from Figure 6 into the final advertisement.

Description of the Invention

A technical advantage of the present invention is that it may be used to significantly reduce the amount of time involved in preparing advertisements. The amount of time reduction is surprising. As a result of the time reductions realized, materials can be submitted weeks in advance—instead of months (which was previously the norm for some users). In some cases, advertising materials can be created in a matter of hours (and possibly minutes in the cases of one page advertisements).

20 Another technical advantage of the present invention is that it may be used to significantly reduce the cost involved in preparing advertisements. The cost savings is surprising.

Another technical advantage of the present invention is that the method and systems permit a user to create high quality advertisement materials without the services of a graphic artist, thereby realizing unexpected savings in time and expense.

Another technical advantage of the present invention is that the method and systems permit a user to direct the electronic transfer of a final or non-final advertising file to a commercial printer (which can be local, within the same city, or

distant, outside the country) or other destination such as, for example, a desk top printer, an e-mail account, a website, or a facility for further processing.

Another technical advantage of the present invention is that the method and systems permit a user to eliminate the time associated with certain queues (e.g., the
5 queue of the graphic artist who designs a layout for an ad), thereby realizing unexpected savings in time.

Another technical advantage of the present invention is that the method and systems permit a user to print its own advertisements, which will result in greater control over printing costs and timing. Printing "in house" also eliminates the delay
10 of queues that may exist when projects are delivered to a commercial printer.

Another technical advantage of the present invention is that the method and systems are easily used, and the databases are easily updated.

Another technical advantage of the present invention is that the method and systems are easily customized to provide a unique look for each user, and to provide
15 uniformity from advertisement to advertisement, thereby, helping a user to create branding among its trademarks.

Another technical advantage of the present invention is that the method and systems provide cost-effective advertisement services, well below the rates charged by professional designers.

Another technical advantage of the present invention is that the method and systems permit a user to maintain up-to-date product databases in order to facilitate
20 the creation of accurate and current advertisements.

Another technical advantage of the present invention is that the method and systems facilitate the provision of services to users who desire to have another
25 person or entity create and maintain user product databases.

Another technical advantage of the present invention is that the method and systems permit flexibility in the creation of advertisements, in the sense that advertisements may be created using any number of colors, as well as in black and white.

- 8 -

Another technical advantage of the present invention is that the method and systems are easily used, and the databases are easily updated.

Another technical advantage of the present invention is that the method and systems can be easily updated through software upgrades to include the latest
5 fashions in advertisement design services.

Another technical advantage of the present invention is that the method and systems are modified to provide links to other web pages so that the latest information concerning new and existing products can be integrated into the databases of the present system, as well as to provide access to others so that they
10 can obtain the latest information about a user's products and services.

Another technical advantage of the present invention is that the method and systems permit a service provider (one who operates the present invention) to calculate and prepare a co-op report for each user. Moreover, the software associated with the method and systems of the present system permit a service
15 provider to process orders and arrange payment to a printer on behalf of a user.

Another technical advantage of the present invention is that the method and systems permit a user to rapidly create high quality advertisement materials.

Another technical advantage of the present invention is that the method and systems permit the use of the Internet as a platform for the development and product
20 of new advertising materials, thereby providing a fast and technologically sophisticated method for creating advertising. The system of the invention permits even a novice to easily create sophisticated advertisements.

The preferred embodiment of the present invention and its advantages are best understood by referring to Figures 1 through 7 of the drawings, like numerals
25 being used for like and corresponding parts of the various drawings.

Referring to Figure 1, a general purpose computer for use with the present invention is provided. Processor 102 has input/output section 104, central processing unit 106, and memory section 108. Input/output section 104 may be connected to keyboard 110, display unit 112, disk storage unit 114, and CD-ROM
30 drive unit 116. CD-ROM unit 116 can read a CD-ROM medium 118, which

typically contains programs and data 120. In one embodiment, the general purpose computer may lack some or all of the features described above. For example, the general purpose computer may operate as a terminal, an emulator, etc. with network access.

5 The present invention is directed to a system for computer-created advertisements. Referring to Figure 2, a system according to one embodiment of the present invention is provided. The system may include a plurality of network access devices 202, such as the general purpose computer described in Figure 1, may be used. In one embodiment, network access devices 202 may include wireless
10 devices, including wireless Personal Digital Assistants (“PDAs”) (e.g., Palm™ VII, Research in Motion’s Blackberry™), wireless web-enabled phones, pagers, etc.

 Network access device 202 may interface with at least one network 250. Network 250 may include the Internet, one or more Local Area Networks (“LANs”), one or more Metropolitan Area Networks (“MANs”), one or more Wide
15 Area Networks (“WANs”), one or more Intranet, etc. An interface between network access device 202 and network 250 may be provided as is known in the art. By way of example, and without limitation, the interface may be provided by unshielded twisted pair wiring, such as CAT-5, coaxial cable, telephone lines, fiber optic cables, or any other suitable communication medium. In one embodiment, network access
20 devices 202 may interface with network 250 via a wireless interface.

 Server 210 may support the software used in conjunction with the present invention. In one embodiment, server 210 may access product database 212 and template database 214, which will be discussed in greater detail below. Server 210 may access network 250 in a manner as described above.

25 In one embodiment, printer 220 may be provided. Printer 220 may produce electronic or hard copies of the advertisement, as will be discussed in greater detail below. Printer 220 may access network 250 in a manner as described above.

 In another embodiment of the present invention, and referring to Figure 3, a method for computer-created advertisements according to one embodiment of the
30 present invention is provided. In step 302, advertising formats are displayed for the

- 10 -

user. In step 304, the user selects an advertising format to use. In step 306, at least one template corresponding to the selected advertising format may be displayed. In step 308, at least one product reference is displayed for the user. In step 310, the user selects at least one product reference. In step 312, the selected product reference may be displayed on the template. In step 314, a preview of the advertisement may be created for the user. In step 316, the user may review the preview, and, if satisfactory, may authorize the production of the advertisement. In step 318, the advertisement may be produced, in an electronic format, in a printed format, etc.

10 Sample screenshots that correspond to steps in the method of Figure 3 are provided as Figures 4-7. A detailed discussion of the method of Figure 3 will be provided, below.

 In a preferred embodiment of the present inventions, the systems and methods utilize a program that is template-based and includes a database of products offered by a user. The template and its "look" are preferably controlled by the company manufacturing or supplying the products to permit the user to create a consistent and desirable public image, while simultaneously allowing the user flexibility in specifying the content of its advertisements. Predetermined descriptions, graphics, logos, images and associated items may be stored in a database for ease of navigation, but the flexibility of inserting a custom price and description for the various products may also be provided to the user. Preferably, the program may be customized for each user to give the user's advertisements a distinctive design and functionality.

 In another preferred embodiment, a user may specify the number of pages to be included in an advertisement, as well as certain printing specifications. For example, a user may specify a delivery method for an advertisement (e.g., direct mailing to potential users), a quantity, a paper size, drop shipping information, and other like printing information. By way of example, after completing the design of an advertisement, a user may cause the service provider's server to deliver information files electronically to a printer for printing and distribution.

- 11 -

In another preferred embodiment, a user may specify the electronic delivery of a final or non-final advertisement to a target audience via e-mail or by posting it on one or more websites. This enables a user to produce both printed and electronic advertisements through the systems and methods of the invention.

5 The invention reduces the development time from months to weeks, (and in some cases, days or even hours), thereby substantially increasing efficiency and reducing time to develop a final advertisement. The present inventions permits the designing advertising, printing and delivering of a final product to a target audience in a rapid, cost-effective manner.

10 The present invention is also directed to a software program developed to significantly reduce the time and frustration associated with current methods of developing a newspaper advertisement. This Internet based program allows a user (e.g., a store owner) to access a web site through the click of an icon, to select a template, a number of pages, and other information, and to point and click through a
15 systematic method of circular development. Upon login, the store owner is preferably presented with updates and messages about new vendors, special sales or new additions to the program. Through a library of suppliers categorized by vendor, store department, SKU and product description, a store owner may select products that are desired to be advertised. The store owner may place the selected products
20 into pre-designed templates, and may also take advantage of predetermined company advertisements. The ads preferably have sufficient flexibility to permit creativity, and yet sufficient standardization to keep the process easy. Upon completion of the design process to create an advertisement, a store owner may dictate print or display specifications to specify, for example, quantity, destination,
25 pricing, drop ship and/or payment information. Preferably, the present invention is accompanied by help menus to assist the user in designing an advertisement. Preferably, the advertisement may be electronically transmitted to a professional printer for processing, printing and delivery. Upon receipt of the file, the professional printer may generate a preview (e.g. printer's proof or other hard-copy,
30 electronic preview), which preview may be transmitted to the store owner (by way

- 12 -

of facsimile, electronic mail, or courier) along with final pricing and a production confirmation. The commercial printer may also provide a co-op claim calculations report. Turnkey co-op claim filing and processing may also be provided . Preferably, the program library (i.e., the database) of suppliers is updated regularly
5 in order to reflect current available products and/or inventory.

The present invention requires a computer. Preferably, the computer includes a modem (e.g. dial-up connections such 14.4, 28.8 or 56K modem, DSL, cable), more preferably high speed, or other access interface (e.g. a T1 or T3 connection, satellite) to permit high speed access to a server. Preferably, the
10 computer includes software to permit rapid and reliable access to the Internet, preferably the user has an account with an Internet access provider. In setting up an Internet connection, it may be desirable to utilize cache to keep local copies of frequently accessed pages, and thus reduce the demands on bandwidth to the network.

15 In one embodiment of the present invention, a user utilizes an Internet connection in order to access a web site on a host computer. The web site may, for example, be maintained and hosted by a commercial printer, a supplier, or an Internet Service Provider. The web site, when accessed, may request a user to log into the site by entering a username and password.

20 Generally, a user will specify the advertising format that is desired. Preferably, the user selects an advertising format from a plurality of advertising formats displayed on the computer screen. More preferably, the user selects from a pull down menu of advertising formats. An advertising format establishes the type of advertisement that is desired. Examples include circulars that are distributed by
25 hand to potential users, newspaper inserts that are distributed as part of a newspaper, direct mail advertisements that are mailed directly to potential users, newsletters that are distributed to existing clients in order to keep them informed, and banners. Advertising materials that may be generated using the present invention are not limited to these examples, but may include any kind of print, digital, electronic or
30 other form of advertisement.

When the user selects an advertising format such as, for example, a newsletter, the present invention will provide the user an opportunity to prepare a custom newsletter. Preferably, the user will have the opportunity to specify the number of pages in the newsletter, as well as to include a table of contents, product photos, and descriptive text. In one embodiment, the present invention may present the user with a plurality of options from which the user may choose (e.g., 2 pages vs. 4 pages, double-sided vs. single-sided). Upon completion of the design phase, the newsletter may be processed and electronically transferred to a commercial printer for printing. The commercial printer may print the advertisement, providing the user with hard copies that may be distributed directly to existing customers as well as potential customers of the user. Alternatively, the user may duplicate the prints using the user's own facilities, thereby achieving further savings in time and money. Yet another alternative is for the commercial printer to process the advertisement after receiving the electronic files.

When the user selects a newspaper ad as an advertising format, the present invention will provide the user an opportunity to prepare a custom newspaper ad. Preferably, the user will have the opportunity to specify the size of the advertisement (e.g., full page, half page, quarter page, etc.), as well as to include product photos, pricing information (e.g. price, discount, sale, rate, coupon, etc.) and other descriptive text. Upon completion of the design phase, the ad is preferably transferred electronically to a newspaper company for inclusion in a newspaper. Alternatively, the ad may be transferred electronically for processing at a commercial printer, and then transferred electronically to a newspaper company for publication.

When the user selects a circular as an advertising format, the present invention will provide the user an opportunity to prepare a custom circular. Preferably, the user will have the opportunity to specify the number of pages in the circular, as well as to include product photos, pricing information and other descriptive text. In one embodiment, the present invention may present the user with a plurality of options from which the user may choose (e.g., 4 pages vs. 8

pages). Upon completion of the design phase, the circular is preferably transferred electronically for processing and printing at a commercial printer. The commercial printer may process and print the circular, and thereafter, provide hard copies to newspaper companies, if desired. Alternatively, the ad may be transferred
5 electronically for processing at a commercial printer, and then transferred electronically to a newspaper company for publication.

Once an advertising format has been selected, a user may select a template that corresponds to the selected advertising format. In one embodiment, the present invention will provide a one-to-one correspondence between available advertising
10 formats and templates. It is recognized and understood, however, that a selected advertising format may have a plurality of templates that correspond to the selected format. Moreover, different advertising formats may share one or more templates. In the case of a one-to-one correspondence, the selection of an advertising format may pre-ordain the selection of a template.

15 Preferably, after selecting an advertising format, the user will be provided by the present invention with an opportunity to select one of a plurality of templates that correspond to a selected advertising format. For example, if a circular is chosen as an advertising format, the user may be presented with a plurality of pre-defined templates for a circular. By selecting one of the pre-defined templates, the user will
20 be able to save much time in designing a custom circular. It is understood and acknowledged, however, that the present invention may also be designed to permit a user to have even greater flexibility by presenting a template that provides a user with greater flexibility in terms of overall layout and design.

In a preferred embodiment, the present invention includes a database of
25 templates, which database can be readily accessed and regularly updated. The database may be organized such that each template is allocated a record. Of course, the present invention contemplates that many other known means of organizing data and databases may be used to maintain a plurality of templates for purposes of this invention.

Once a template is chosen, the user is provided with an opportunity to customize the template. In the case where a template involves multiple pages, the user may be provided with an opportunity to select a page of the template to design and/or edit. In either event, the user may begin to customize the advertisement.

5 In a preferred embodiment, the user may be presented with options to include pre-defined product ads as well as new product ads that the user may create. A pre-defined product ad is one that was created previously and saved into memory (e.g., stored into a database or otherwise on a computer memory). Alternatively, the pre-defined product ad may be saved as part of a template, in which case the next time a
10 template is used, it may be defined to include the pre-defined product ad. Preferably, templates include additional areas that permit new products to be advertised. Figure 1 illustrates a template that includes pre-defined advertisements, as well as providing blocks where custom product ads may be placed. One way of readily identifying areas where new product ads may be placed is by coloring an
15 area of the template with a color. That way, a user readily sees a blank portion on the template and may "import" (or otherwise add by way of an editor) a new product ad.

In one embodiment, a template may include a pre-determined window that permits a user to specify an expiration date for an advertisement, or even a range of
20 effective dates for the advertisement. For example, the user may be presented with a menu to enter two dates "D1" and "D2", and the menu may automatically add text to the template that provides that the advertisement is good from D1 through D2.

Preferably, each template includes areas wherein a user may add custom text. Custom text may describe a particular product or refer to the overall advertisement
25 (e.g., "Special Sale," "We Install" or "We appreciate your business."). A user friendly way of designing this feature is to provide an area on the template wherein text and/or images may be added simply by clicking on the area and pasting the text and/or images. Optionally, a menu may be used to enter custom text and/or images into an area on a template. For purposes of this document, areas wherein custom
30 text and/or images may be placed shall be referred to as "advertisement areas" or,

- 16 -

more simply, "ad areas." The ad area may be configured to be a square, a rectangle, a circle, or other geometric shape. Color may also be used to designate the physical limits of an ad area. An ad area may also be comprised of multiple boxes. For example, an ad area may have one box for an image file, one box for text, and one
5 box for a price. (The use of the term "box" is not intended to be limited to any particular geometric shape.)

In a preferred embodiment, the template may include multiple ad areas, and the ad areas may be different shapes and/or sizes. Each of the multiple ad areas may be the same or a different color. Each of the multiple ad areas, preferably, may be
10 easily modified in terms of placement on the template, as well as in terms of physical size. The ability to adjust the placement and/or the size of each ad area will facilitate the design process.

An ad area may be customized, for example, to emphasize a theme, such as Independence Day Sale, Memorial Day Sale, or even, Congratulations to the Local
15 Graduating Class. When used for developing a theme, the ad area may be used to hold a graphic image (such as fireworks, flags, or a graduation cap) and/or text directed to the theme. Once a theme is developed, a user may choose to save the theme template as a custom template for future use.

An ad area on a template may be configured to receive one or more product
20 references, thereby permitting a user to customize a template in the process of creating an advertisement. A user may customize a template by adding one or more product references to the template. A product reference may include images of a product to be advertised and/or custom text that describes one or more aspects of the product (e.g., price, size, weight, specifications, etc.). A product reference may
25 include other information relating to the product, for example, SKU numbers, barcodes, trademarks, logos, etc. For purposes of this document, information concerning a product to be advertised such as, for example, one or more of text blocks which may include pricing information, pictures, characters, images, designs, sketches, colors, manufacturer logos, shall be referred to individually and
30 collectively as a product reference. The overall appearance of the desired

information (i.e. collection of chosen product references) for a particular product or products may also be referred to as product presentation.

In a preferred embodiment, the system and the method of the present invention may provide the user with assistance in setting the price for a product to be advertised. For example, the present invention may provide the user with historical pricing information for the product being advertised (for example, a 50 foot long roll of masking tape), and/or pricing information on products within a particular category (for example, all rolls of masking tape). This feature will help to minimize the occurrence of pricing errors, which will help to minimize damage to good will associated with such errors. The pricing information provided by the pricing assistance program may include, lowest sale price, highest regular price, average sale price, etc.

It is contemplated that a user may desire to choose among multiple product references for the identical product. For example, a user may select a first product reference that includes an image of "Product A" and text describing Product A. Alternatively, a user may select a second product reference that comprises only text describing Product A. Alternatively, a user may select a third product reference that comprises only an image of Product A. In addition, the user may select a fourth product reference, which is similar in all respects to the first product reference, but which has a different layout of the image relative to the text. For example, the image may be larger in one product reference, and the price may be in a larger font or type size for emphasis. The option to choose between the first product reference and the fourth product reference will permit a user to design an advertisement with consistency from product ad to product ad, or to choose layout variety from product ad to product ad. In a preferred embodiment, the user will have multiple product references for each given product, which references vary in both content as well as layout.

When designing an advertisement, a user may have the option of adding one or more product references to the template. Preferably, the user is presented with a plurality of product references from which to choose. The presentation of the

product references on a computer screen may include an image of a particular product and/or text that describes one or more aspects of the product. Often, a user may have thousands of products that it may be interested in advertising. In such a case, it is preferable that the product references be organized by at least one methodology, and more preferably, by multiple methodologies. For example, 5 product references may organized generally by generic category descriptions (say, "Books," "Magazines," "Clothing," "Gifts," "Hardware," etc.) It may be preferred that the generic categories have subcategories as well. For example a generic category such as "clothing" may be further categorized into "boots," "hats," 10 "jewelry," "shirts," etc. Another methodology for organizing product references is by individual vendors who supply products. By clicking on one of the two windows, the user is provided with a pull-down menu of categories or vendors, and by selecting one of the provided references, the user is further provided with a portion or all of the product references that are associated with the user's prior 15 selections (e.g., all of the hats, some of the shoes, etc.).

The system maintains in a memory storage device a list of product references. In a preferred embodiment, the present invention includes a database of product references, which database can be readily accessed and regularly updated. The database may be organized such that each product reference is allocated a 20 record, which includes an image (or a reference marker that associates an image with the product), and text (or other information) that describes one or more features of the product (for example, title, price, weight, etc.). Of course, the present invention contemplates that many other known means of organizing data and databases may be used to maintain a plurality of product references for purposes of 25 this invention.

The present invention may also utilize multiple databases of product references. This is especially useful when the user is a local office of a national chain. For example, the present invention may use one database of product references for products that are advertised nationally, and a second database of 30 product references for products that are advertised locally. This will permit a user to

participate in a national advertisement campaign, and yet permit the user to add products that are important to a local clientele.

In one embodiment, the user may be provided with the option of using a logo or trademark of a manufacturer for a particular product. This will permit potential users to readily identify the manufacturer of a product that is being advertised. In another embodiment, the optional logo and/or trademark may be included as part of a product reference, and may even be stored in a database of product references, with reference markers associating the logo with the appropriate products.

The present invention also provides the user with the ability to input new product references. In a preferred embodiment the present invention would include a image capture device (such as a digital camera or scanner) which would permit the user to input an image of the product to be advertised. The new product reference optionally would include custom text that describes one or more aspects of the product. Preferably, the system would update its plurality of product references (e.g., by updating its database of product references) to include the new product reference and make it available for the user to select and add to a template.

In a preferred embodiment, the ad area on a template is configured to work with a product reference. For example, the product reference may be stored as an image file. If the image file is a fixed image of 2" x 2", then ad areas may be configured to accept images of the same size, namely, 2" x 2".

More preferably, the ad area on a template is adjustable such that the ad area may be adjusted in size in such a fashion that the product reference is automatically formatted and adjusted in size to fit the resized ad area. In this embodiment the invention takes the dimensions of an ad area (which may be pre-defined, or which may be measured dynamically) and then scales an image file (which image file may include text and/or photographs) of a product reference to fit the dimensions of the ad area. Of course, one skilled in the art will appreciate that this feature may be designed to operate in other fashions. Such an automatic resizing feature has the unexpected advantage of permitting the memory-stored product references to be automatically and dynamically adjusted without having to occupy additional

- 20 -

memory space. Moreover, this feature has the surprising advantage of providing a user with great flexibility in designing a custom advertisement. This feature also has the additional advantage that product images may be stored in any dimension (and, in fact, may be stored at varying image dimensions).

5 An example will readily demonstrate the flexibility of an automatic resizing feature. A user designs a template to include five ad areas, each of which is of a different size. The user utilizes a single database of product references and places a different product reference in each of the five ad areas. Without any additional effort on behalf of the user, each of the five product references is adjusted in size to
10 fit within each of the five user-defined ad areas. Moreover, because of the automatic resizing feature, a user could rearrange the product references on the same template, and the product references would be automatically resized and re-formatted to fit within its new ad areas. This feature permits quick and easy revisions to the layout of an advertisement.

15 The automatic resizing feature also has the unexpected advantage that it can readily accommodate new product references. If for example, in creating a new product reference, the scanner scans a photograph of a product that is 4" x 6", the new product reference can incorporate the entire image file. When the product reference is ready to be added to an advertisement, the system and method of the
20 present invention may automatically adjust the size of the original image file (in this case, 4" x 6") to fit within the dimensions of the particular ad area in the designated template.

 It is envisioned that the automatic resizing feature may operate on all formats of product references. For example, where the product reference is comprised
25 entirely of text and stored in an ASCII format, the automatic resizing feature may adjust the font, type size and/or the layout of the text to fit into a predetermined ad area. Also, where the product reference is comprised entirely of an image and stored in an image format, the automatic resizing feature may adjust the size of the image to fit into a pre-determined ad area. It is also envisioned that the automatic resizing
30 feature may also make any other necessary conversions to accommodate a product

reference. For example, if a pre-determined ad area is formatted to receive only an image file, and the selected product reference is stored as text, the automatic resizing feature may be expected to convert the text into a desired size such that the product reference may be placed upon the particular ad area.

5 In the case where an ad area is comprised of multiple boxes, the user may be presented with an opportunity to input a sale price for a particular item. The user may be presented with a “price window” which is specifically reserved for pricing information, or the user may be presented with a custom text window, wherein the user may enter pricing information as part of the custom text. If the ad area includes
10 a box for an image file, the user may be presented with an opportunity to input an image file (for example, from the product reference database).

 In a preferred embodiment, the user is provided with an opportunity to preview the advertisement as it will look when printed. One way to provide this opportunity is with a “preview” button which upon clicking will automatically
15 display or print an image that looks very much like the final advertisement as it should be printed.

 In a preferred embodiment, the system and the method of the present invention may provide the user with assistance in designing the layout of an advertisement. For example, the present invention may provide the user with an
20 opportunity to identify one or more priorities that the present invention may use in advising the user on a preferred layout. Sample priorities may include the following: maximum size of product image; maximum number of advertised products per page; minimum separation between product references; maximum font or type size; minimum font or type size; predetermined number of product
25 references per page; grouping by manufacturer; and grouping by product category. For purposes of this document, this feature shall be referred to as priority-based layout assistance. The priority-based layout assistance may be utilized on a template that has already been designed by the user, in which case the assistance program may be used to optimize the layout.

In another preferred embodiment, the user may submit a template and a list of product references to be automatically laid-out by the priority-based layout assistance program. It is contemplated that a user may reset priorities and then preview the results based on the new list of priorities. The priority-based layout assistance will work especially well when each product being advertised has multiple product references from which the assistance program may choose. For example, if a top priority is maximum product image size, the assistance program may layout the initial draft advertisement using those product references with the largest images. This means that the product references may include information describing the differences between the various product references for each product. For example, the database of product references may be designed to hold up to 10 product references for each product, whereby the product references are organized from largest product image to smallest product image. In any case, the priority-based layout assistance may provide better refinement in circumstances when there are multiple product references for each of the products being advertised.

When the advertisement has been designed (i.e., when the template has been designed and edited to include all of the products and information that the user decided to include), the user may review the preview as displayed by the computer or the present invention may generate a hard-copy preview or printer's proof for the user to review. How and where the proof is generated depends upon the advertising format that is being used. For example, for a black and white advertisement, the proof may be generated at a printer operated by the user (on the premises of the user). If a multi-colored glossy circular is desired, the proof may be generated by a professional printer that is located remotely relative to the user. To generate a preview, the present invention may transmit electronically the advertisement to a commercial printer, who may process and create an electronic preview or print a hard-copy proof of the final advertisement.

A user may review the preview to confirm that the draft advertisement as created using the present invention is acceptable in terms of content, design, quality, etc. If the user approves of the preview, the final advertisements may be printed,

and preferably, in accordance with any printing specification that may have been provided by the user. In addition, the invention may offer the user an automatic checking feature of prices, quantities, inventory availability (e.g. in store availability or availability from distributor or manufacturer facilities) or other options (e.g. size, color, composition) against preset or predetermined parameters.

It is contemplated that the present invention may be implemented in a manner that provides an account for a user to access, and further that the account provides access to a memory storage device where the user may store data and other information relevant and/or unique to the user. For example, a host computer that may be accessed through an Internet connection may store product references, templates, and other custom information for a user, such that when a user logs into its account, the information is readily available. This approach will also permit certain additional convenience features. For example, a user's files, data, orders, and other information may be automatically saved for the benefit of the user. Further, saving can be set up to occur automatically at periodic intervals, as well as automatically upon the termination of an account session (e.g., upon log-off). The user may also be presented upon a subsequent login, the option of editing a prior session's advertisement or creating a new advertisement. Automatic saving features have the advantage of significantly reducing the risk of lost data, which consequently helps to reduce the time associated with creating subsequent advertisements.

In one embodiment of the present invention, the methods and systems may provide delivery options. For example, a user may chose from a plurality of delivery options that include a) a direct mailing to potential users whose names and addresses are provided by the user, b) a direct shipping to a newspaper publisher, and c) a direct shipping to the user at one or multiple locations. When a direct mailing is selected, the user may preferably provide a data file of names and addresses of persons who will receive hard copies or electronic direct mailings. The data file may be provided, for example, via the Internet or a storage media (e.g. hard drives, zip disks, CDs, diskettes).

In one embodiment of the present invention, the methods and systems may provide print schedules. Print schedules permit a user to plan the logistics of meeting a particular advertising goal. For example, a print schedule may include two dates: 1) a distribution date—which is the date by which a user may wish to have its advertisements distributed; and 2) a publication deadline—which is a date by which the proposed advertisement should be completed in order to meet the distribution date. These dates are typically set by a user based upon the requirements of the user's business and the schedules of the commercial printers that the user will be using in the printing process.

In one embodiment, a user may be presented with a plurality of schedules from which the user may choose. In another embodiment, the user may input a distribution date, and the present invention may calculate the publication date based upon a pre-determined formula (for example, a particular printer requires two weeks notice to print a job).

In another preferred embodiment, the user may submit a template and a list of product references to be automatically laid-out using the pre-defined template and the order of the list of product references. It is contemplated, as well, that a user may define a set of priorities and generate a draft advertisement based on the list of priorities. The priority-based layout assistance will work especially well when each product being advertised has multiple product references from which the assistance program may choose. The advantage of this approach is that the user minimizes its demands on the network interface (e.g., a modem connection). By transmitting the template information and the list of product references, the user avoids having to deal with multiple, large image files, and thus, a significant time savings may be realized. Moreover, the system and method of the present invention contemplates that the host computer may compile a draft advertisement using the template information and the list of product references, which draft advertisement may be transmitted directly from the host computer to commercial printers. In this fashion, the bandwidth demands of the user's network interface are lessened, resulting in a savings on the development time and increased reliability.

- 25 -

Other embodiments and uses of the invention will be apparent to those skilled in the art from consideration of the specification and practice of the invention disclosed herein. All references cited herein, including all U.S. and foreign patents and patent applications, are specifically and entirely hereby incorporated herein by
5 reference. It is intended that the specification and examples be considered exemplary only, with the true scope and spirit of the invention indicated by the claims below. As will be easily understood by those of ordinary skill in the art, variations and modifications of each of the disclosed embodiments can be easily made within the scope of this invention as defined by the claims below.

Claims:

1. A computerized method for a user to create an advertisement, comprising:
displaying on a computer a plurality of advertising formats for selection by
the user;
5 displaying on the computer, in response to selection by the user, a template
that corresponds to a selected one or more of the plurality of advertising formats;
displaying on the computer a plurality of product references for selection by
the user;
displaying on the template at least one selected product reference to create a
10 proposed advertisement; and
creating a preview of the proposed advertisement.
2. The computerized method of claim 1 further comprising:
submitting to a remote site, through a networked connection with the
computer, electronic files of the proposed advertisement, specifications for the
15 proposed advertisement, the specifications including at least one of: a quantity,
printing information, a ship date, delivery or shipping instructions, destination
information, pricing information, a paper type, and a payment method;
creating a preview of the proposed advertisement at the remote site; and
creating advertisements that correspond to the proposed advertisement in
20 accordance with said specifications at the remote site.
3. The computerized method of claim 1 wherein the step of creating a preview
of the proposed advertisement is selected from the group consisting of: a) displaying
a preview of the proposed advertisement on a computer and b) printing a hard-copy
preview of the proposed advertisement.
- 25 4. The computerized method of claim 1 wherein the step of displaying on the
computer a plurality of product references for selection by the user comprises:
displaying a menu of a plurality of product categories for selection by the
user; and
displaying on the computer, in response to selection by the user, a plurality
30 of product references that correspond to a selected product category.

- 27 -

5. The computerized method of claim 1 wherein the step of displaying on the computer a plurality of product references for selection by the user comprises:
- displaying on the computer a menu of a plurality of vendors for selection by the user; and
 - 5 displaying on the computer, in response to selection by the user, a plurality of product references that correspond to a selected vendor.
6. The computerized method of claim 1 wherein the step of displaying on the template at least one selected product reference comprises:
- 10 displaying on the template at least one advertisement area for selection by the user;
 - displaying on a selected advertisement area at least one selected product reference; and
 - displaying on the selected advertisement area information for the at least one selected product reference.
- 15 7. The computerized method of claim 6, wherein the information is pricing information.
8. The computerized method of claim 1 wherein the selected advertising format is chosen from the group consisting of a circular, a newspaper advertisement, a hard-copy banner, an electronic banner, a flyer, signage, direct-mail advertisements,
- 20 electronic-mail advertisements, a store newsletter and combinations thereof.
9. An electronic method for a user to create an advertisement, comprising:
- accessing a web site through a computer;
 - displaying on the computer a plurality of advertising formats for selection by the user;
 - 25 displaying on the computer, in response to selection by the user, a template that corresponds to a selected one or more of the plurality of advertising formats;
 - displaying on the computer a plurality of product references for selection by the user;
 - displaying on the template at least one selected product reference to create a
 - 30 proposed advertisement;

- 28 -

submitting to a remote site, via a network connection, electronic files of the proposed advertisement, specifications for the proposed advertisement, the specifications including at least one of a quantity, printing information, a ship date, delivery or shipping instructions, destination information, a paper type, pricing
5 information, and a payment method;

creating, at the remote site, a preview of the proposed advertisement;

making the preview available to the user for review; and

creating, in accordance with the specifications, the advertisement that corresponds to the proposed advertisement.

10 10. The electronic method of claim 9 further comprising:

displaying on the computer a menu whereby the user may enter information concerning at least one custom product reference; and

displaying on the template at least one custom product reference in addition to the at least one selected product reference.

15 11. The electronic method of claim 9 wherein the step of displaying on the computer a plurality of product references for selection by the user comprises:

displaying on the computer a menu of a plurality of product categories for selection by the user; and

20 displaying on the computer, in response to selection by the user, a plurality of product references that correspond to a selected product category.

12. The electronic method of claim 9 further comprising:

logging into an account that is maintained on the web site using information that uniquely identifies the user;

25 automatically saving, in response to the completion of each step, the proposed advertisement as a prior proposed advertisement, such that upon a subsequent login into the account, the user will be presented with an option of editing the prior proposed advertisement.

30 13. The electronic method of claim 9 further comprising printing a plurality of the advertisements at said remote site and choosing a delivery option for the printed advertisements selected from the group consisting of: a direct mailing to potential

users whose names and addresses are provided by the user; a direct shipping to a newspaper publisher; and a direct shipping to the user at one or more locations.

14. The electronic method of claim 13, wherein the chosen delivery option is a direct mailing to potential users, said method further comprising:

5 transmitting, via the Internet or a storage media, a data file comprising names and addresses of potential users to whom the advertisements should be mailed.

15. The electronic method of claim 9 further comprising:

displaying on the computer a schedule comprising two dates: a distribution date; and a publication deadline wherein said publication date is when the advertisement is expected to be completed to meet the distribution date.

16. A computerized system for creating an advertisement, comprising:

a template database for storing a plurality of advertising formats;

a product database for storing a plurality of product references;

a computer that has access to the template database and the product database,

15 said computer capable of accessing software that can create one or more of:

a template selector for selecting at least one template from the template database;

a product selector for selecting at least one product reference from the product database, each of the at least one product reference including at least one of an image and text; or

20 a design interface for controlling the placement of a selected product reference on a selected template to create a proposed advertisement;

said computer having a network interface so that a user may create a proposed advertisement.

17. The computerized system of claim 16, wherein the network interface is an Internet interface, said system further comprising:

a printer to print a proposed advertisement, said printer being connected to the computer via the Internet interface.

- 30 -

18. The computerized system of claim 16, wherein the product selector comprises:
- a menu of a plurality of product categories for selection by the user; and
 - a plurality of product references for at least one of the plurality of product
- 5 categories.
19. The computerized system of claim 16, further comprising:
- a receiver for receiving a preview of the proposed advertisement;
 - a transmitter for transmitting an approval for the preview, electronic files of
- the proposed advertisement, specifications, and an authorization to transfer or
- 10 display the proposed advertisement.
20. The computerized system of claim 16, wherein the computer is capable of accessing software that can create :
- a specifications interface for inputting specifications for the
- advertisement, said specifications including at least one of a quantity,
- 15 printing information, a ship date, shipping destinations, delivery instructions, a paper type, pricing information, and a payment method.
21. The computerized system of claim 16, wherein the template selector comprises:
- a menu of a plurality of advertising formats, said menu permitting a selection
- 20 from the group consisting of a circular, a newspaper advertisement, a hard-copy banner, an electronic banner, a flyer, signage, direct-mail advertisements, electronic-mail advertisements, a store newsletter and combinations thereof.
22. The computerized system of claim 16, wherein the template comprises:
- 25 at least one advertisement area whereupon a product reference may be placed;
- said at least one advertisement area also being capable of displaying pricing information for at least one product reference.
23. The computerized system of claim 16, wherein the product reference
- 30 comprises at least one of an image of a product for sale and text.

24. A computerized system for creating an advertisement, comprising:
a template database for storing a plurality of advertising formats;
a product database for storing a plurality of product references;
5 a computer that has access to the template database and the product database,
said computer capable of accessing software that can create:
a template selector for selecting at least one template from the
template database;
a product input interface for adding new product references to
10 the template database;
a product selector for selecting at least one product reference
from the product database, each of the at least one product reference
including at least one of an image and text; and
a design interface for controlling the placement of a selected
15 product reference on a selected template to create a proposed
advertisement;
said computer having a network interface to create a proposed advertisement.
25. The computerized system of claim 24, wherein the product input interface
comprises:
20 an input for receiving digital data from an image capture device, which
device can be used to generate an image of a new product;
an input for receiving textual information about the new product; and
a data marker for linking the digital data and the image.
26. The computerized system of claim 24, wherein the product input interface
25 further comprises an image capture device selected from the group consisting of a
digital camera and a scanner.
27. The computerized system of claim 24, wherein the computer is capable of
accessing software that can create:
an editor for editing a product reference.

28. The computerized system of claim 24, wherein the editor is configured to edit any graphics and any text that may be associated with a product reference.

29. An Internet-based method for a user to create an advertisement, comprising:
accessing a website through a computer, said website being hosted on a host
5 computer, and said host computer having access to a first database of advertising
formats and a second database of product references;

accessing the first database to identify a plurality of advertising formats;

displaying on the computer the plurality of advertising formats for selection
by the user;

10 displaying on the computer, in response to selection by the user, a template
that corresponds to a selected one or more of the plurality of advertising formats;

accessing the second database to identify a plurality of product references;

displaying on the computer the plurality of product references for selection
by the user;

15 displaying on the template at least one selected product reference to create a
proposed advertisement;

submitting to a remote site via the Internet, electronic files of the proposed
advertisement, specifications for the proposed advertisement, the specifications
including at least one of a quantity, a ship date, a destination, delivery instructions,
20 pricing information, printing information, a paper type, and a payment method;

creating, at the remote site, a preview of the proposed advertisement;

making the preview available to the user for review; and

displaying or transferring, in accordance with the specifications, the
advertisement that corresponds to the proposed advertisement.

25 30. The Internet-based method of claim 29 further comprising:

displaying on the computer a menu whereby the user may enter information
concerning at least one custom product reference; and

displaying on the template at least one custom product reference in addition
to the at least one selected product reference.

31. An Internet-based method for a user to create an advertisement, comprising:
accessing a website through a computer, said website being hosted on a host
computer, and said host computer having access to a first database of advertising
5 formats and a second database of product references;
displaying on the computer a menu whereby the user may enter information
concerning a custom product reference;
updating the second database to include the information concerning the
custom product reference;
10 accessing the first database to identify a plurality of advertising formats;
displaying on the computer the plurality of advertising formats for selection
by the user;
displaying on the computer, in response to selection by the user, a template
that corresponds to a selected one or more of the plurality of advertising formats;
15 accessing the updated second database to identify a plurality of product
references;
displaying on the computer the plurality of product references for selection
by the user;
displaying on the template at least one selected product reference to create a
20 proposed advertisement;
submitting to a remote site, via the Internet, electronic files of the proposed
advertisement, specifications for the proposed advertisement, the specifications
including at least one of a quantity, printing information, a ship date, a paper type,
pricing information, and a payment method;
25 creating, at the remote site, a preview of the proposed advertisement;
making the preview available to the user for review; and
displaying or transferring, in accordance with the specifications, the
advertisement that corresponds to the proposed advertisement.
32. A method whereby a user operates a computer to create an advertisement,
30 comprising:

selecting an advertising format from a plurality of advertising formats stored on a computer;

displaying on the computer, in response to selection by the user, a template that corresponds to a selected one or more of the plurality of advertising formats,
5 said template including a plurality of advertising areas;

selecting one of a plurality of product references, each of said product references comprising at least one of an image and text;

importing the selected product reference onto one of the plurality of advertising areas to create an advertisement, whereby said advertising area is
10 configured to automatically format the selected product reference to fit within physical dimensions of the advertising area.

33. The method of claim 32, wherein the product advertising area is configured to automatically scale the selected product reference to fit within physical dimensions of the advertising area.

15 34. The method of claim 32, wherein the advertising area is configured to automatically convert the product reference into a scaled image with physical dimensions that are about the same as the physical dimensions of an advertising area.

20 35. A method whereby a user operates a computer to create an advertisement, comprising:

selecting an advertising format from a plurality of advertising formats stored on a computer;

displaying on the computer, in response to selection by the user, a template that corresponds to a selected one or more of the plurality of advertising formats,
25 said template including a plurality of advertising areas;

selecting a plurality of product references, each of said product references comprising at least one of an image and text;

specifying at least one rule of priority for laying out the plurality of product references onto the plurality of advertising areas;

- 35 -

generating an advertisement whereby the plurality of product references are placed onto the plurality of advertising areas in accordance with the at least one rule of priority.

36. The method of claim 35, wherein the step of selecting a plurality of product
5 references comprises:

selecting a plurality of products to be advertised, each of said products having a corresponding plurality of product references, each of which product references comprises image, text or image and text, and each of which corresponding product references differ in size of an image and size of a text font,

10 wherein the rule of priority is to maximize the size of the images for each of the selected products, when said product references are laid-out on a template.

37. The method of claim 35 whereby the rules of priority are chosen from the group consisting of: maximum size of product image; maximum number of advertised products per page; minimum separation between product references;
15 maximum font size; minimum font size; predetermined number of product references per page; grouping by manufacturer; and grouping by product category.

38. A computerized system for creating an advertisement, comprising:

a template database for storing a plurality of advertising formats;

a product database for storing a plurality of product references;

20 a computer that has access to the template database and the product database, said computer capable of accessing software that can create:

a template selector for selecting at least one template from the template database, each of said at least one templates having at least one advertisement area;

25 a product selector for selecting at least one product reference from the product database, each of the at least one product reference including at least one of an image and text; and

a design interface for controlling the placement of a selected product reference onto an advertisement area of a selected template to
30 create a proposed advertisement, said design interface including

- 36 -

software to automatically format the selected product reference to fit within physical dimensions of an advertising area;

said computer having a network interface to create a proposed advertisement.

39. A computerized system for creating an advertisement, comprising:

5 a template database for storing a plurality of advertising formats;

a product database for storing a plurality of product references;

a computer that has access to the template database and the product database, said computer capable of accessing software that can create:

10 a template selector for selecting at least one template from the template database, each of said at least one templates having a plurality of advertisement areas;

a product selector for selecting a plurality of product references from the product database, each of the product references including at least one of an image and text;

15 a design interface that permits a user to specify at least one rule of priority for laying out the plurality of product references onto the plurality of advertisement areas; and

20 an advertisement generator that generates a proposed advertisement wherein the plurality of product references has been laid out on the plurality of advertisement areas, all in accordance with the at least one rule of priority;

said computer having a network interface to create a proposed advertisement.

40. The method of claim 39 whereby the network interface is selected from the group consisting of an Internet connection, a broad-band based connection, a modem
25 connection, connection through storage media, and combinations thereof.

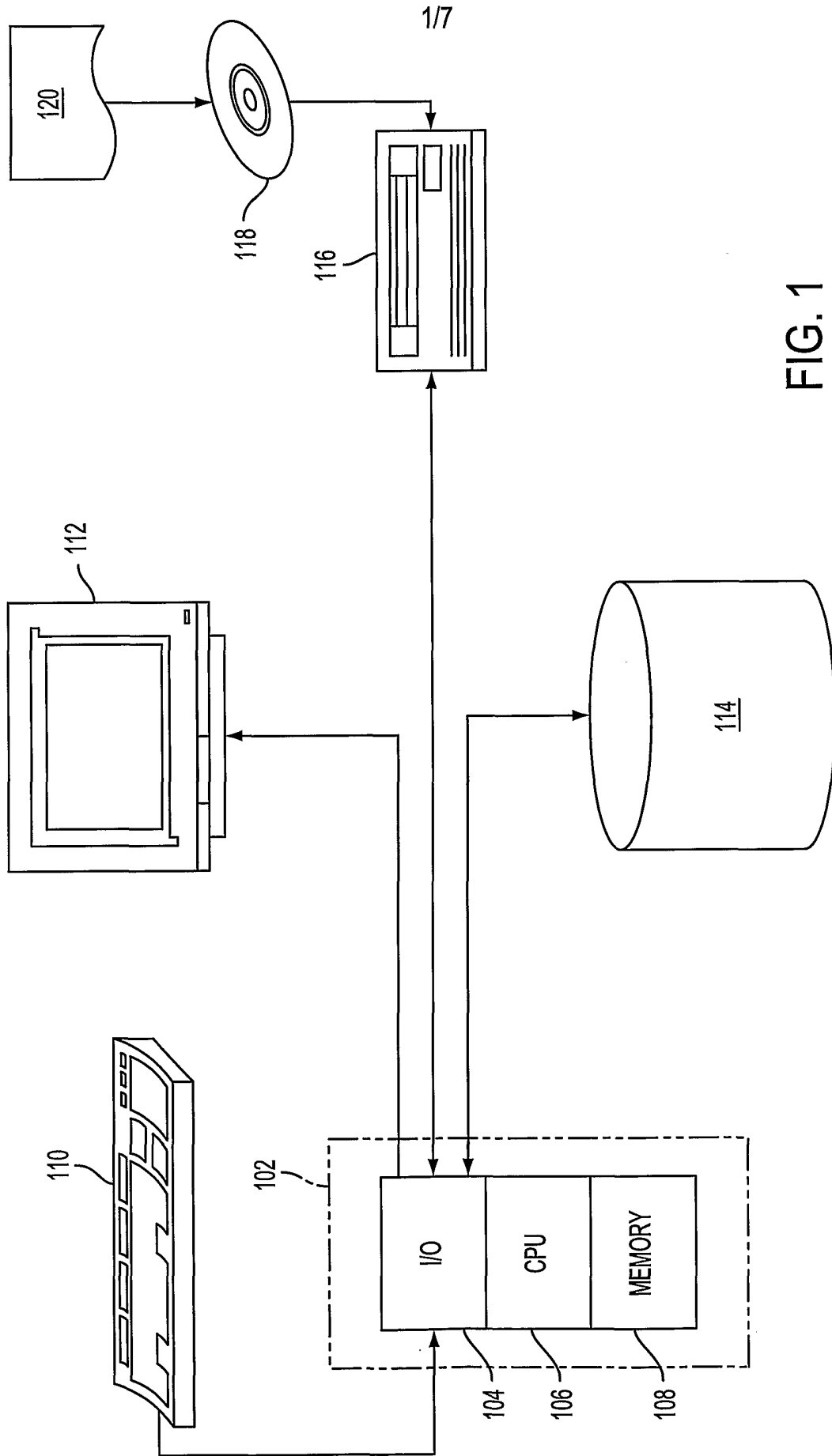

FIG. 1

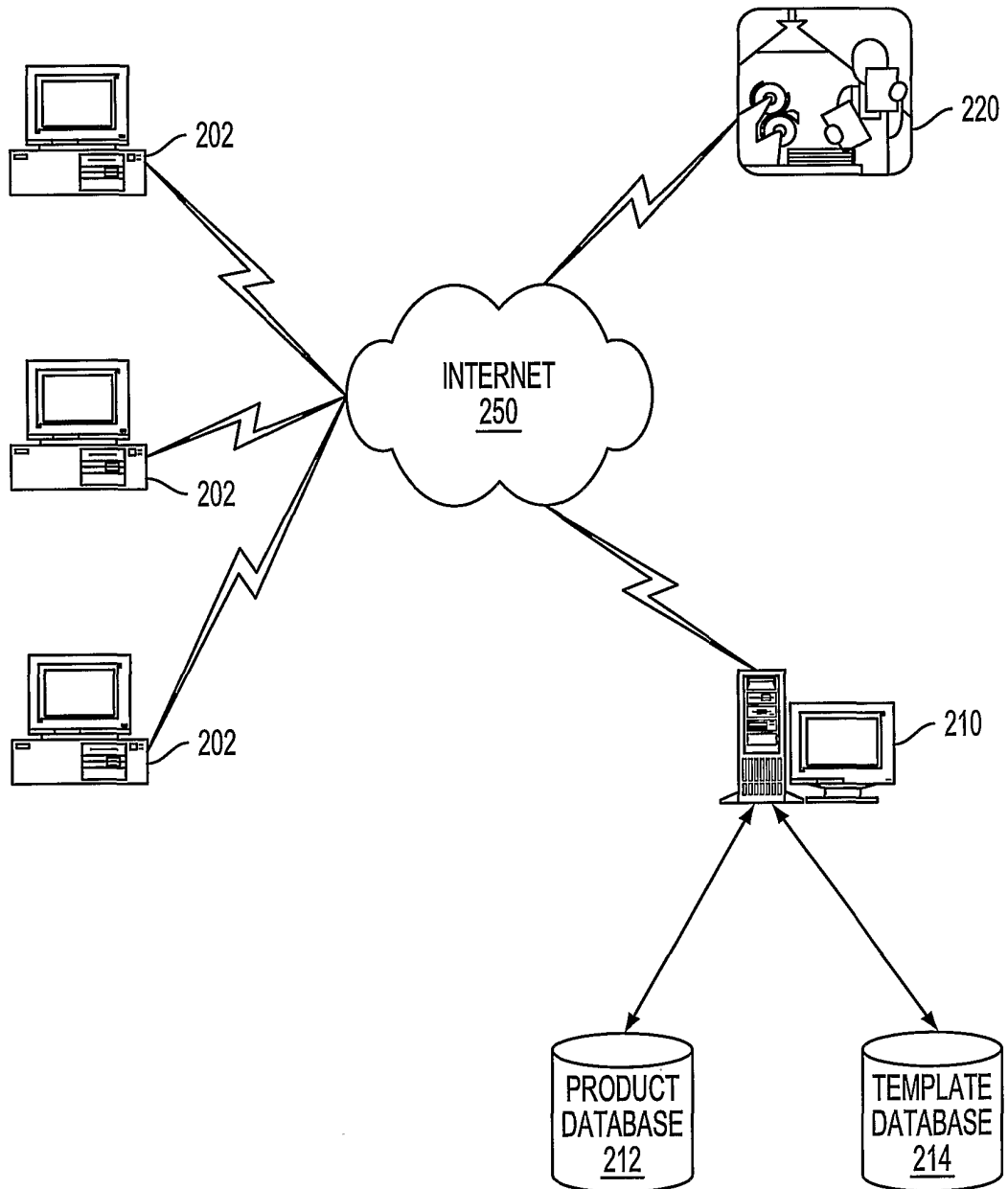

FIG. 2

3/7

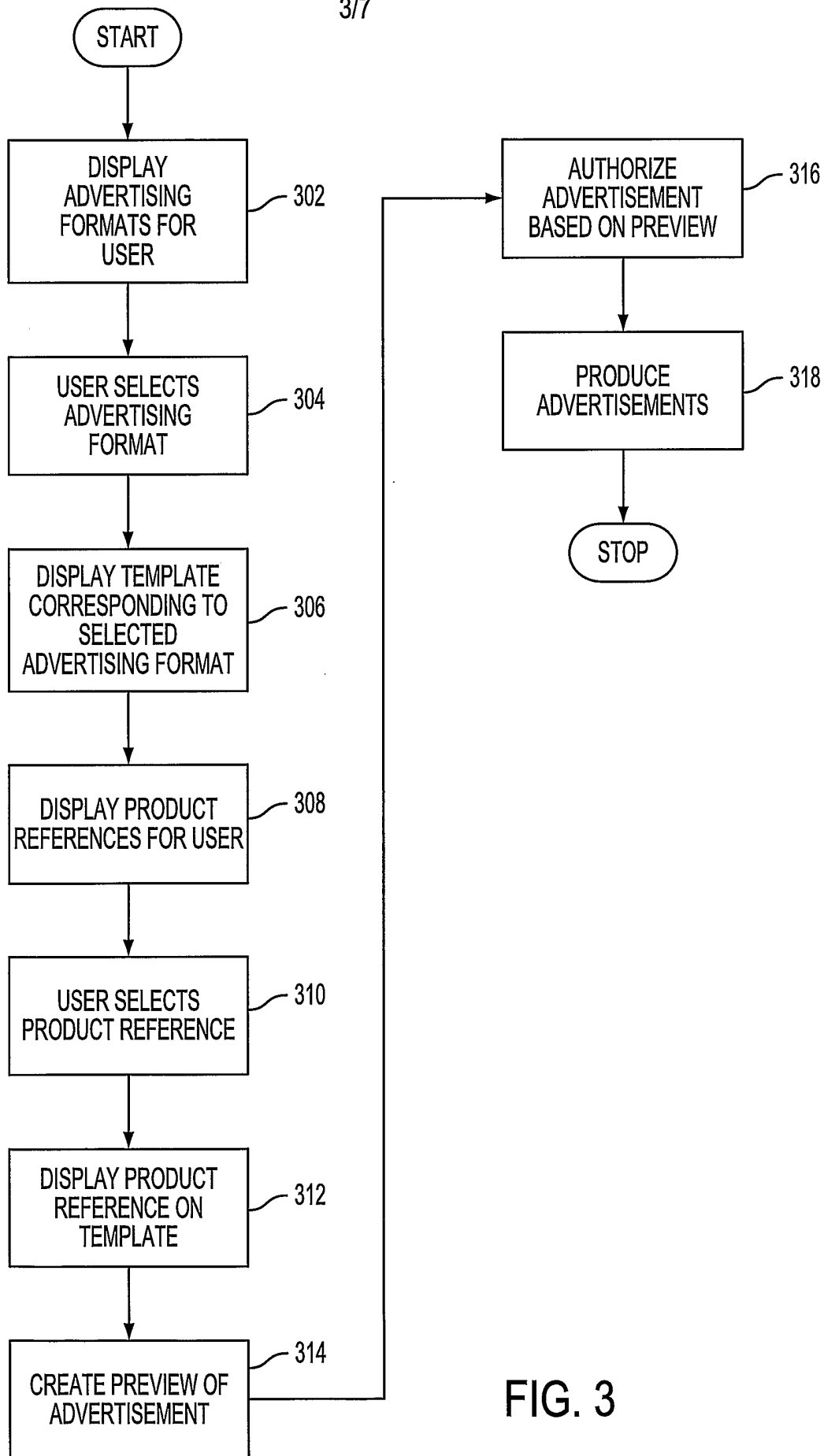

FIG. 3

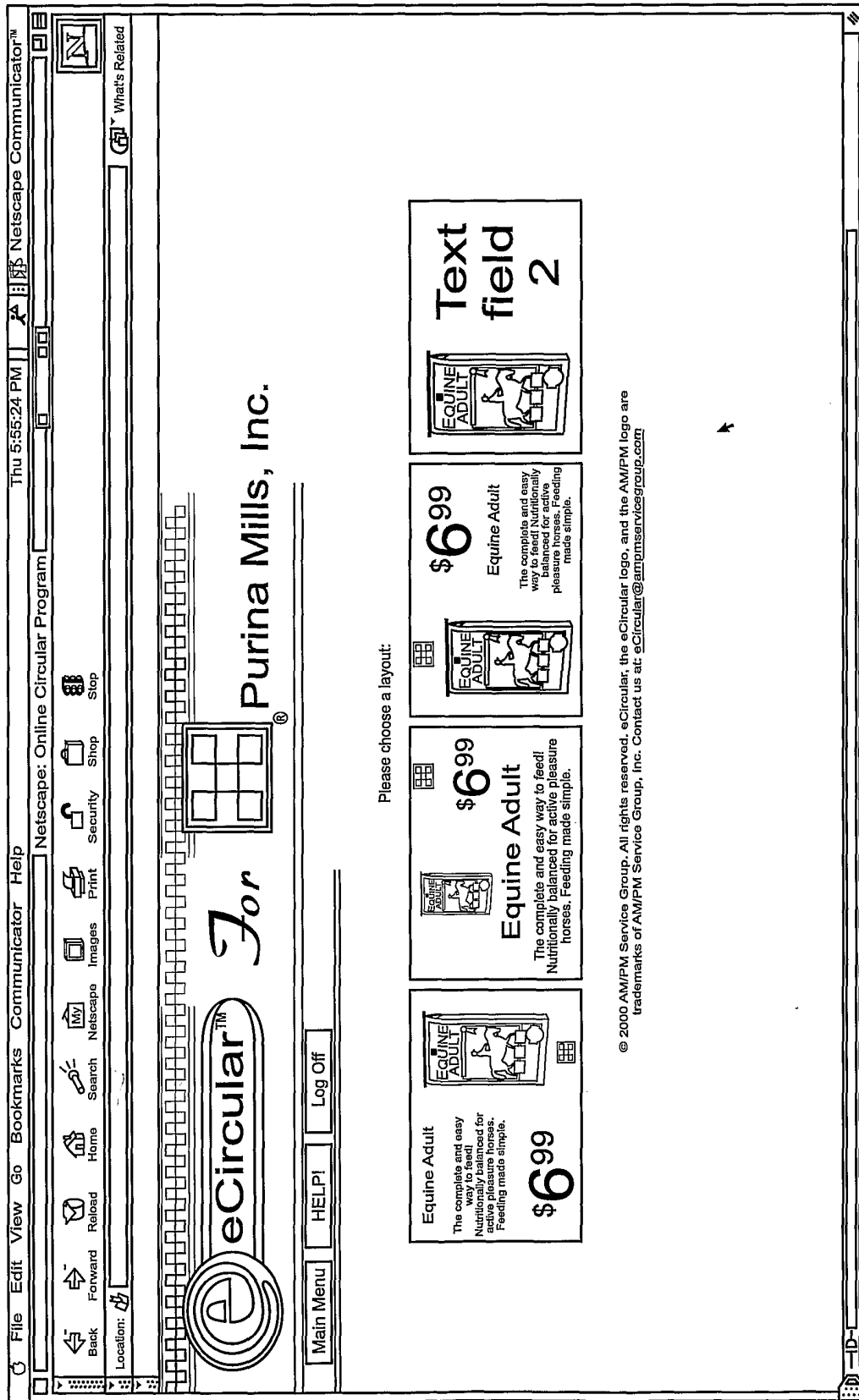

FIG. 4

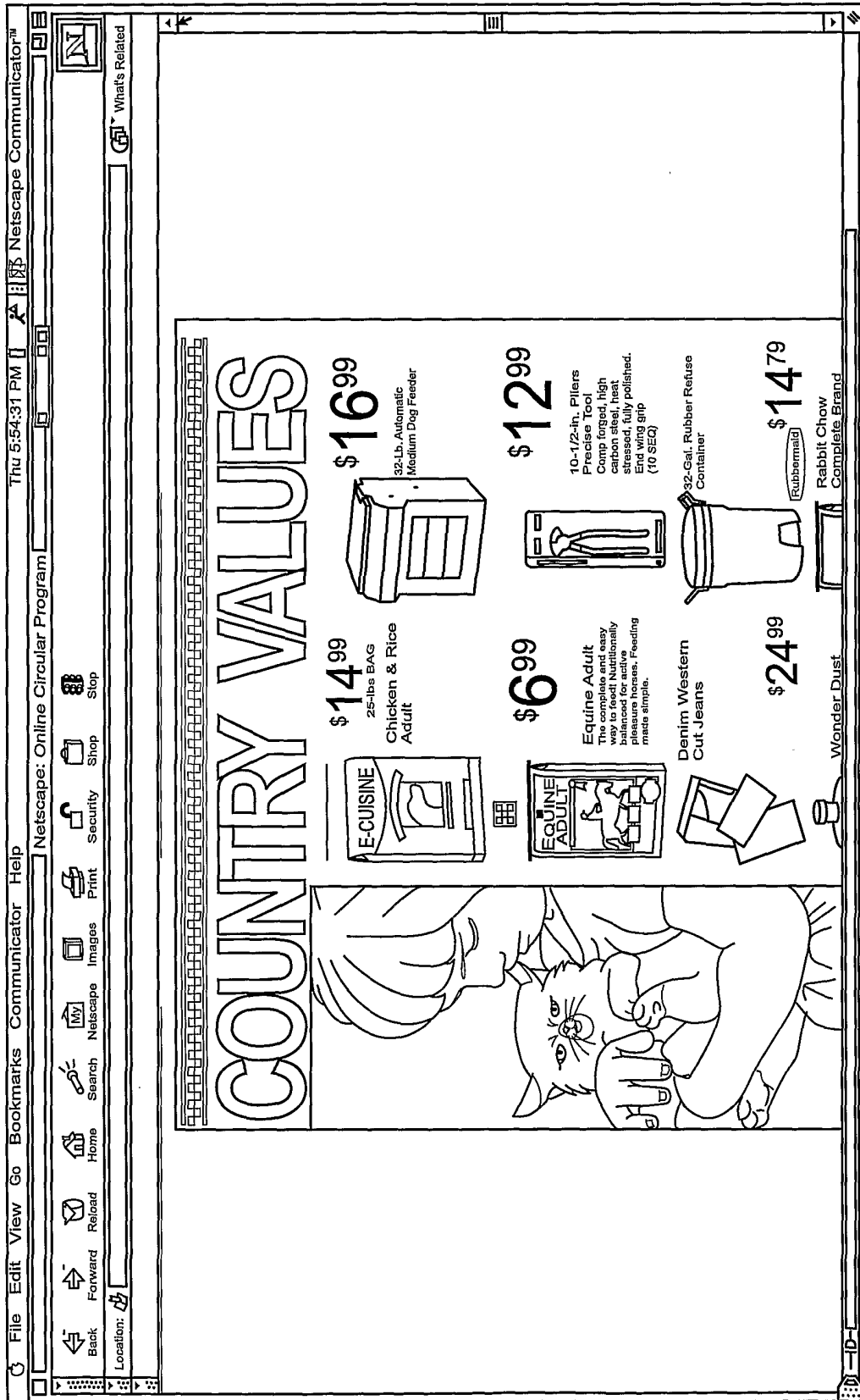

FIG. 5

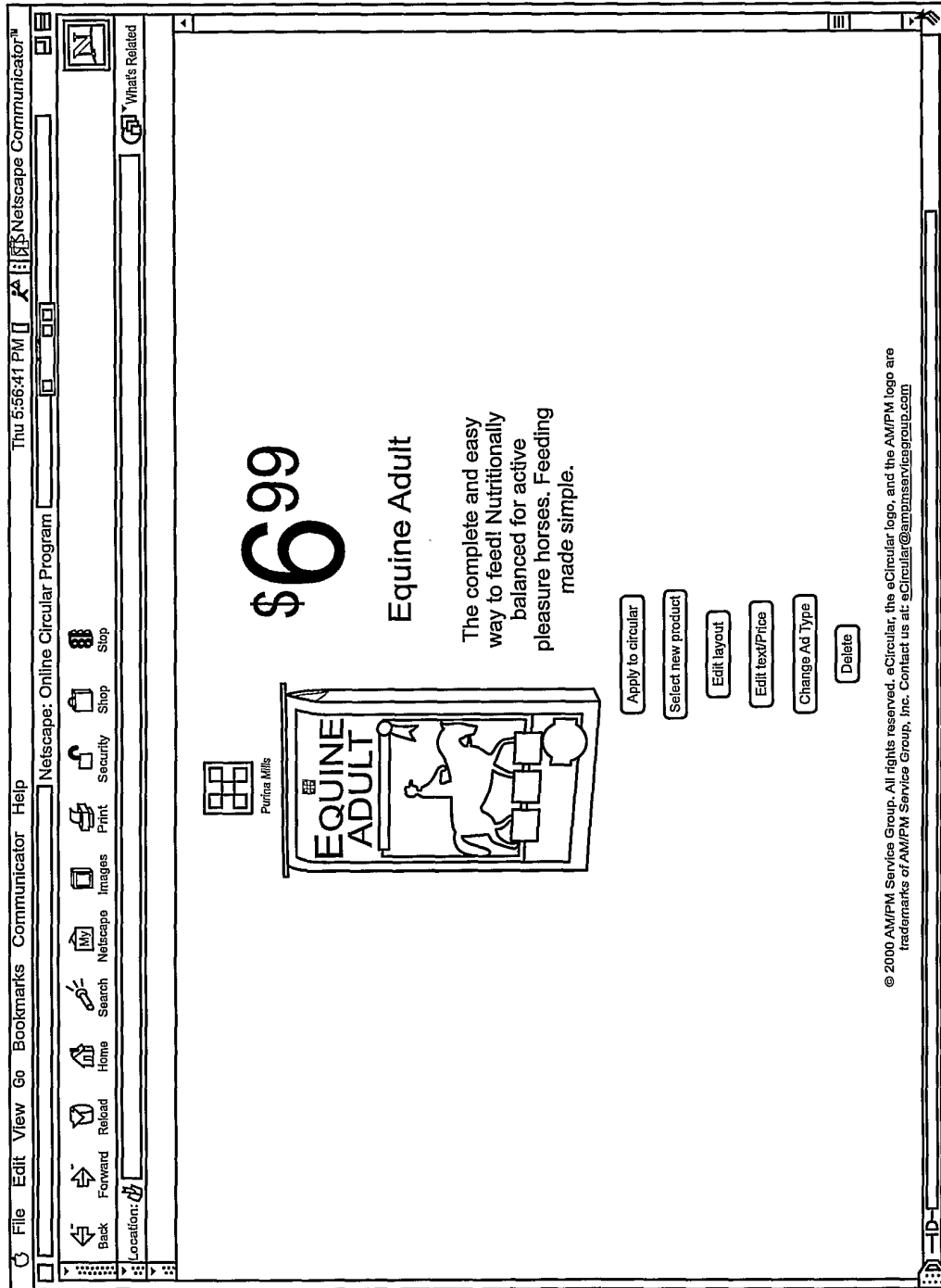

FIG. 6

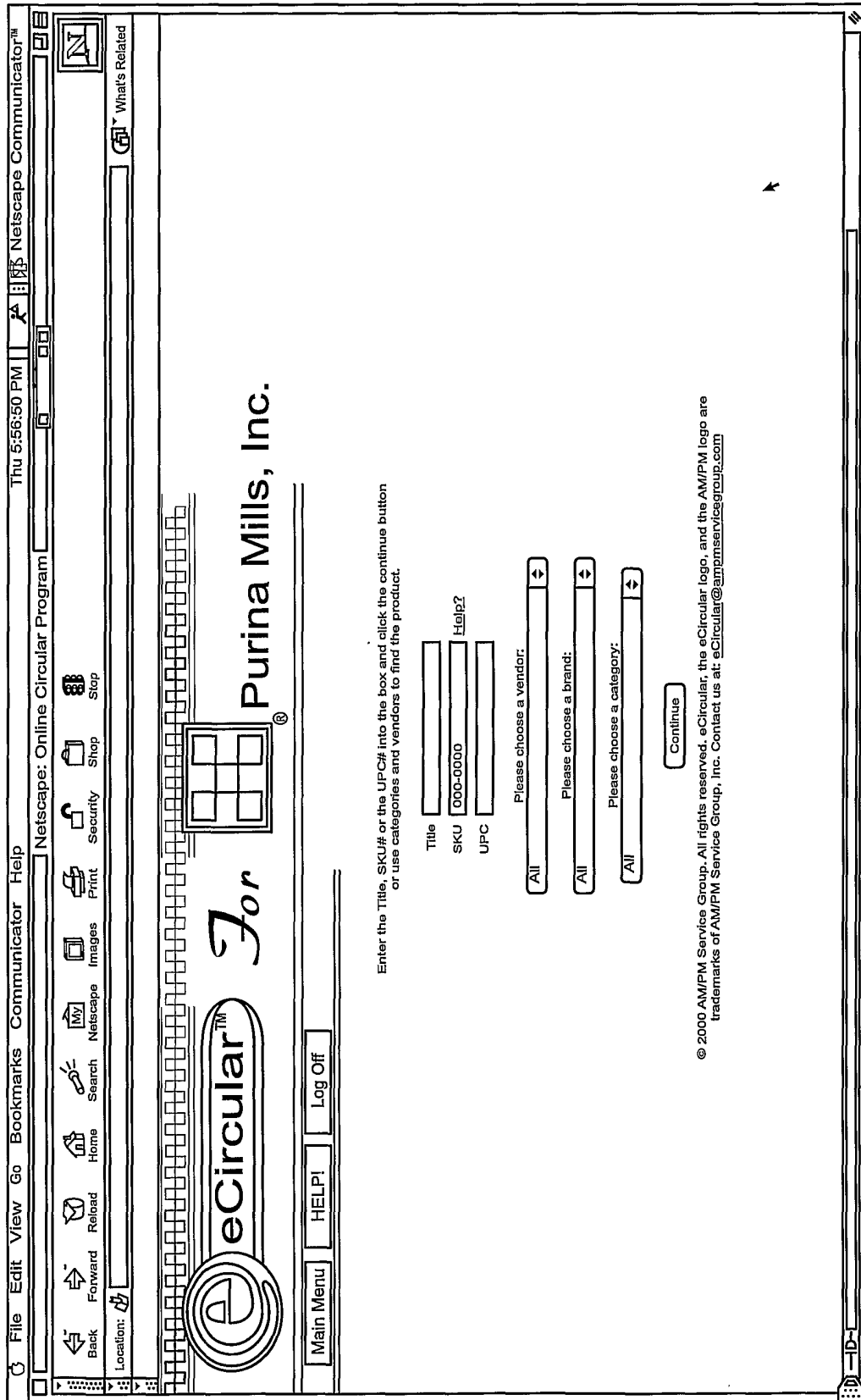

FIG. 7