



(19) **United States**

(12) **Patent Application Publication**
Greenbaum

(10) **Pub. No.: US 2020/0260796 A1**

(43) **Pub. Date: Aug. 20, 2020**

(54) **VAPORIZATION DEVICE HAVING
REMOTEY CONTROLLABLE
OPERATIONAL MODES**

(52) **U.S. Cl.**
CPC *A24F 47/008* (2013.01); *A24F 1/32*
(2013.01); *G07C 9/00103* (2013.01); *G07C*
9/00119 (2013.01)

(71) Applicant: **GLAS, INC.**, Los Angeles, CA (US)

(72) Inventor: **Sean Greenbaum**, Los Angeles, CA
(US)

(21) Appl. No.: **16/674,922**

(22) Filed: **Nov. 5, 2019**

Related U.S. Application Data

(63) Continuation of application No. 16/276,261, filed on
Feb. 14, 2019, now Pat. No. 10,531,693.

Publication Classification

(51) **Int. Cl.**
A24F 47/00 (2006.01)
G07C 9/00 (2006.01)
A24F 1/32 (2006.01)

(57) **ABSTRACT**

Vaporization devices having portions to enable signal transmission therethrough. A vaporization device includes a body having a first end, a second end, and forming an internal cavity. At least a portion of the internal cavity forming a cartridge receptacle. The vaporization device includes a battery disposed within the internal cavity and a processor operatively coupled to the battery and disposed within the body. The processor is arranged to respond to a signal to switch the vaporization device between a first operational mode and a second operational mode. The vaporization device also includes a portion of the body arranged to permit transmission of the signal through the portion of the body from a location external to the body, thereby permitting the processor to switch the vaporization device between the first and second operational modes in response to the receipt of the signal.

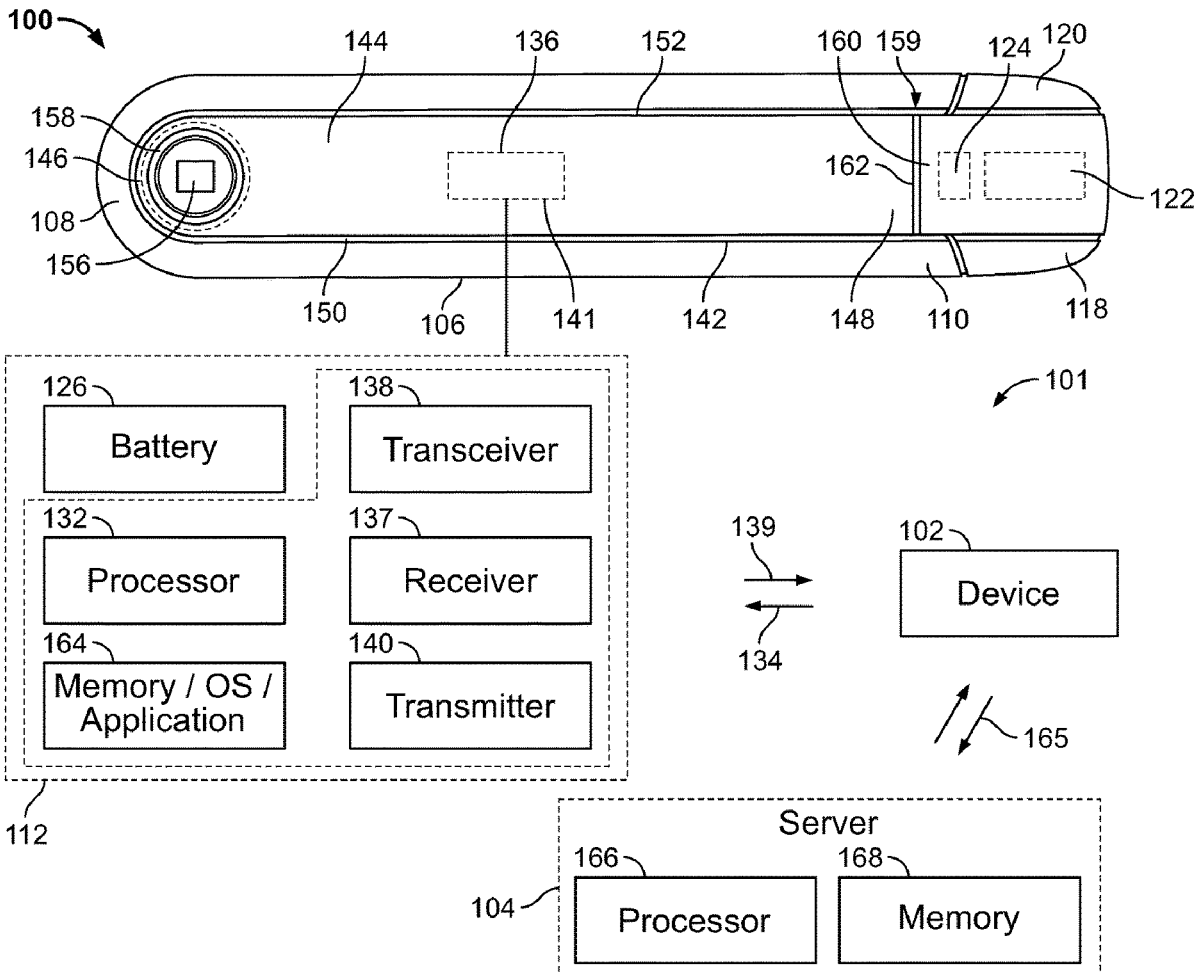

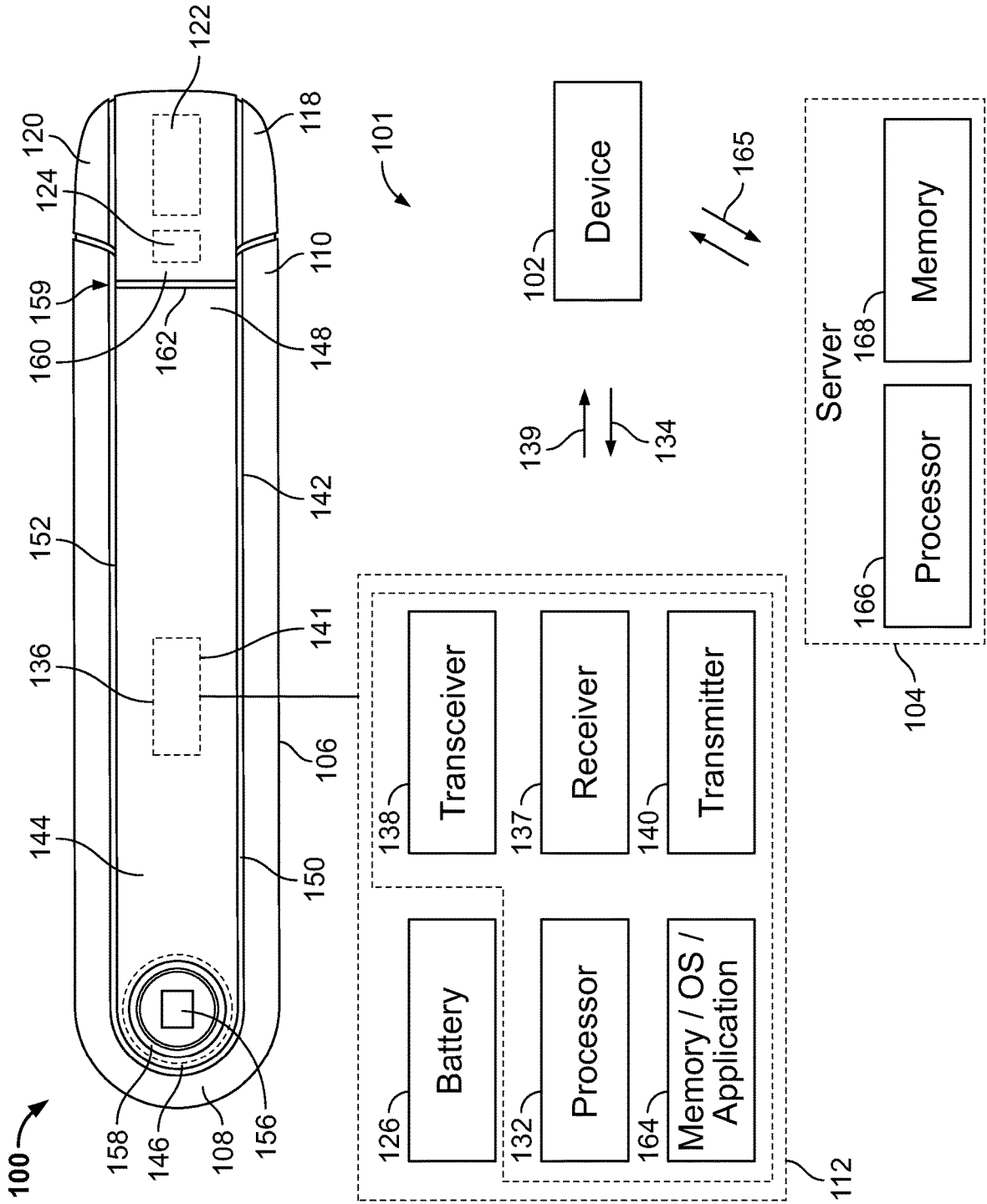

FIG. 1

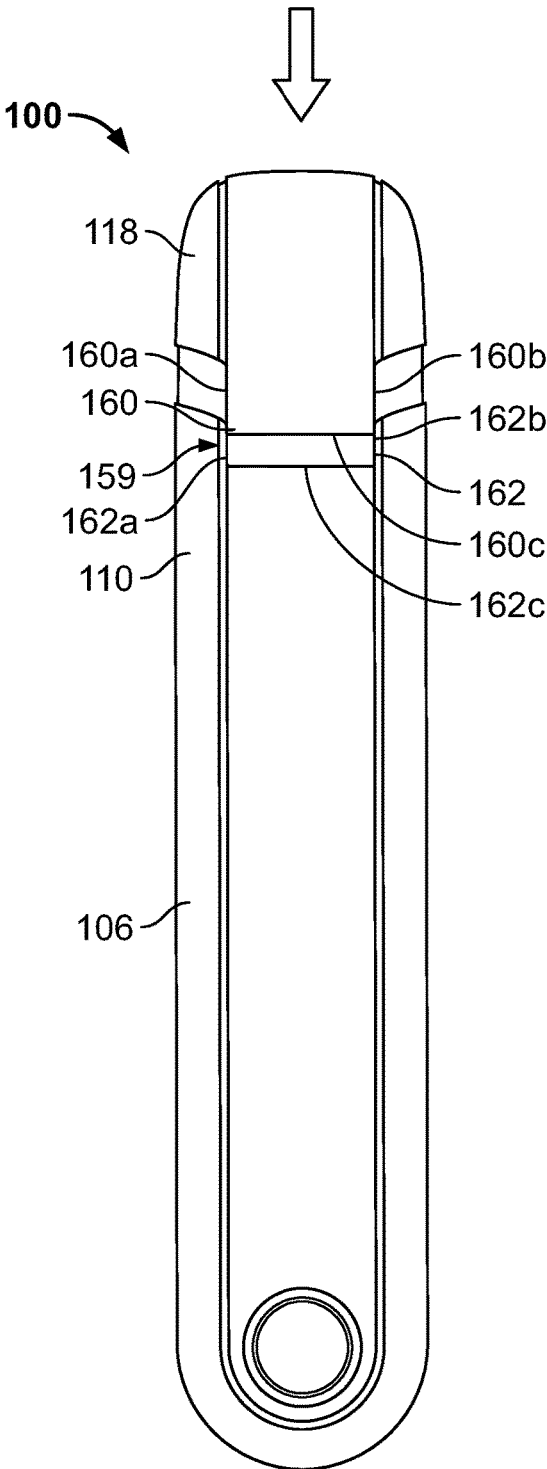

FIG. 2A

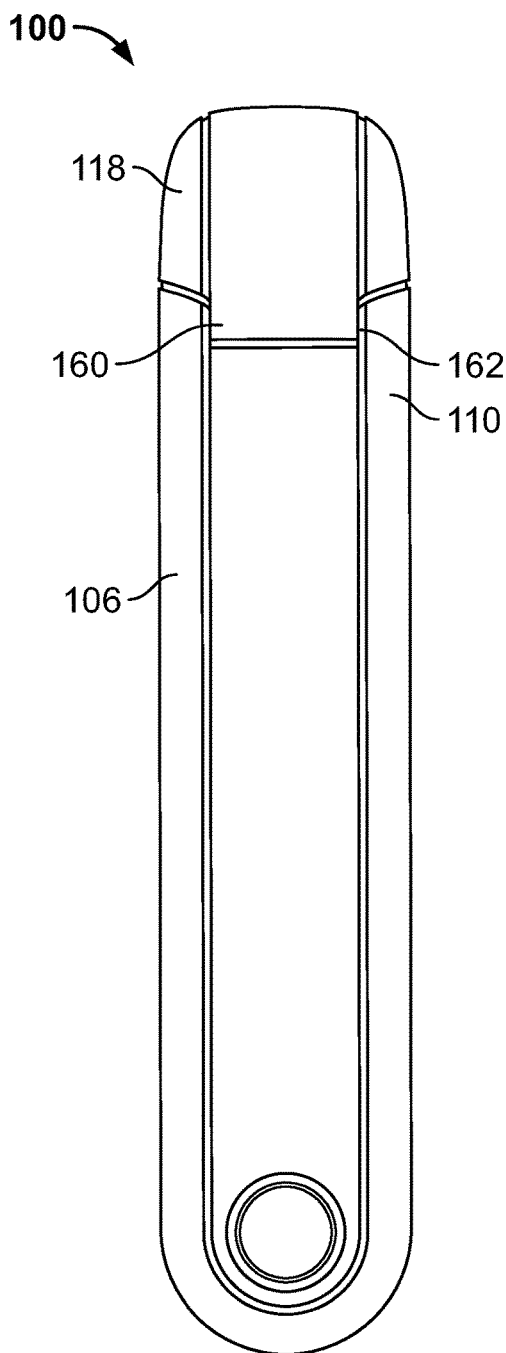

FIG. 2B

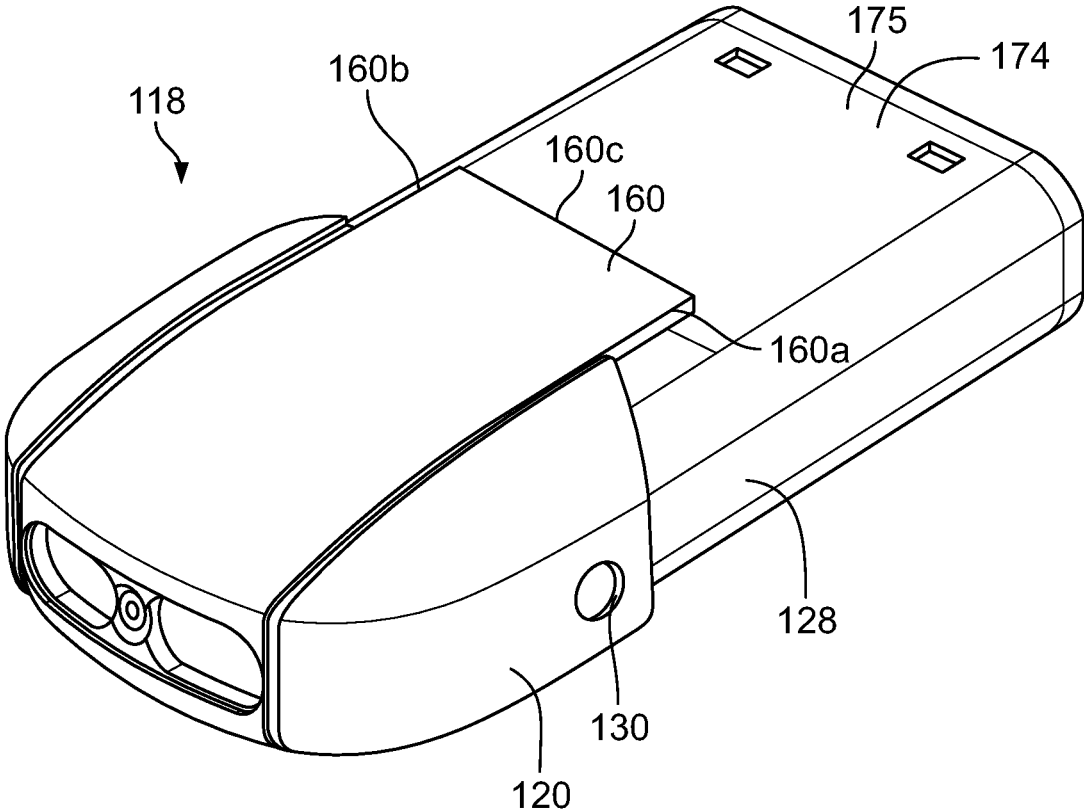

FIG. 3

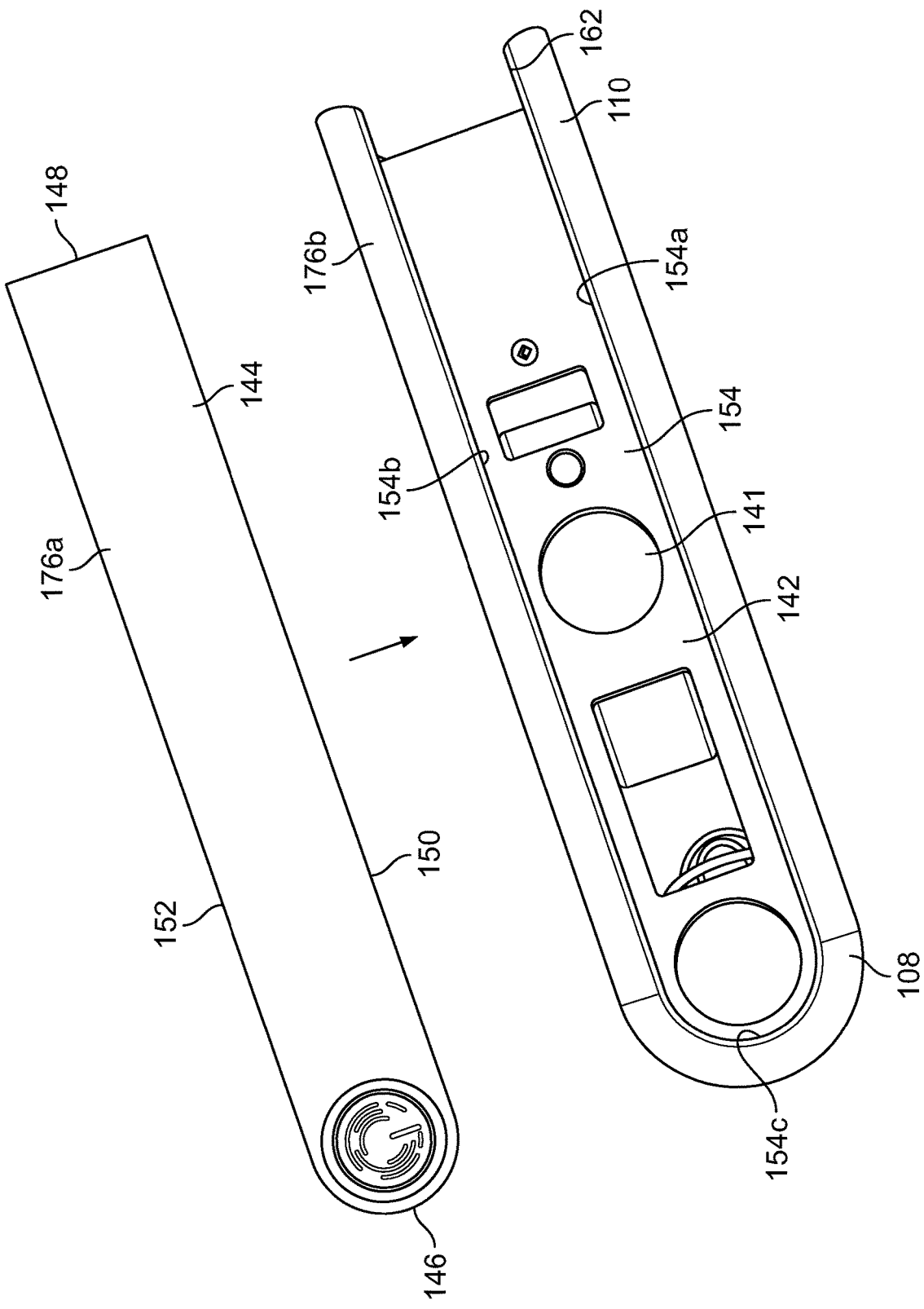

FIG. 4

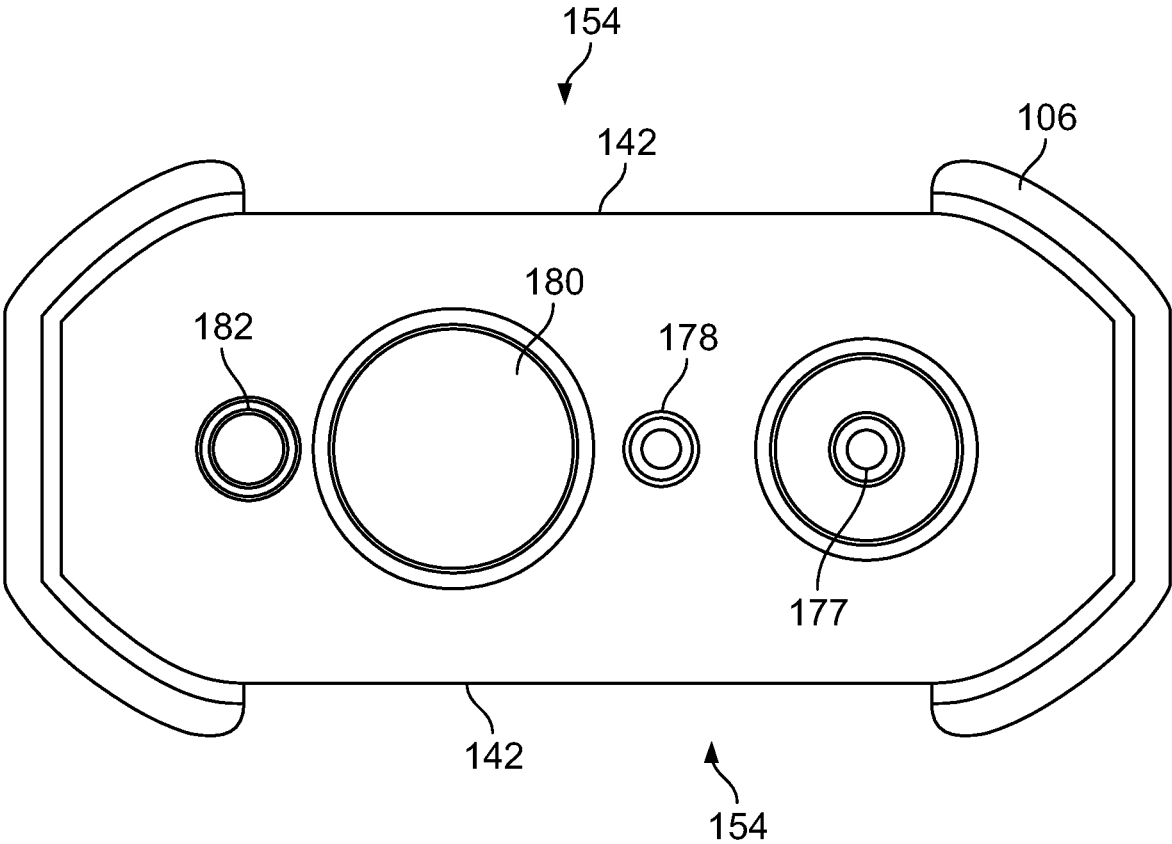

FIG. 5

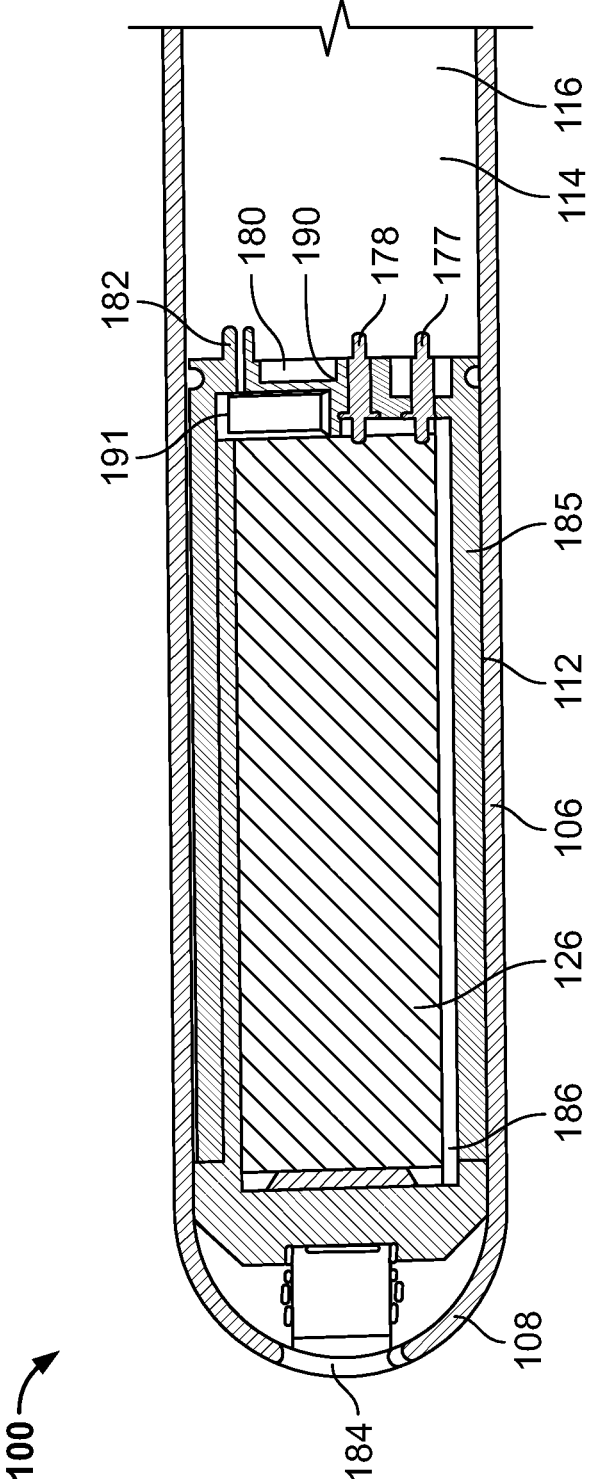

FIG. 6

**VAPORIZATION DEVICE HAVING
REMOTELY CONTROLLABLE
OPERATIONAL MODES**

FIELD OF THE DISCLOSURE

[0001] The present patent relates generally to vaporization devices and, in particular, to vaporization devices that can be enabled or disabled remotely.

BACKGROUND

[0002] Vaporization devices are generally well known in the art. Such devices are typically battery-powered and are often used as smoking substitutes, to simulate smoking or as a smoking sensation aid. Vaporization devices typically include a battery, a heating element and a cartridge that contains a storage container that houses a vapor forming medium. The vapor forming medium often includes a liquid suspension containing nicotine, or one of many other vaporizable substances commonly employed in the art. In practice, the user draws air through the device via a mouthpiece, which activates the heating element such that the vapor forming medium is heated by the heating element to form the resulting vapor. The vapor may be mixed with the air drawn by the user to form an inhalable aerosol.

[0003] Those familiar with the industry may be concerned about use of the vaporization device by an unauthorized user. An unauthorized user may be someone who doesn't own the device, or may be, for example, a minor. Consequently, there exists a need in the art for a manner of limiting access to the device to only an authorized user or users.

SUMMARY

[0004] In accordance with a first example, a vaporization device includes a body having a first end, a second end, and forming an internal cavity. At least a portion of the internal cavity forms a cartridge receptacle that is sized to receive a cartridge having a storage container of vaporizable liquid. The vaporization device includes a heating element and a battery operatively coupled to one another and disposed within the internal cavity. The heating element is arranged to apply heat to and vaporize a quantity of the vaporizable liquid in the storage container. The vaporization device also includes a processor operatively coupled to the battery and the heating element and disposed within the body. The processor is arranged to respond to a signal to switch the vaporization device between a first operational mode and a second operational mode. A portion of the body is arranged to permit transmission of the signal through the portion of the body from a location external to the body, thereby permitting the processor to switch the vaporization device between the first and second operational modes in response to the receipt of the signal.

[0005] In accordance with a second example, a vaporization device includes a body having a first end, a second end, and forming an internal cavity. At least a portion of the internal cavity forms a cartridge receptacle. The vaporization device includes a cartridge having a mouthpiece and a storage container for storing a vaporizable liquid. The vaporization device includes a battery disposed in the cavity and arranged to power a heating element. The heating element is positioned to apply heat to and vaporize a quantity of the vaporizable liquid in response to activation by a user. A processor is operatively coupled to the battery and disposed

within the body. The processor is arranged to respond to an external signal to switch the heating element between a first operational mode and a second operational mode. The processor is further arranged to generate a response signal. A mobile device is arranged to send the external signal and to receive the response signal. A portion of the body is arranged to permit transmission of the external signal through the portion of the body from a location external to the body, thereby causing the processor to switch the vaporization device between the first and second operational modes in response to the receipt of the signal. The portion of the body is further arranged to permit transmission of the response signal through the portion of the body from a location within the body, thereby allowing the mobile device to indicate a status of the vaporization device.

[0006] In accordance with a third example, a vaporization device includes a body forming an internal cavity. At least a portion of the internal cavity forming a cartridge receptacle. A female structure is defined by an exterior surface at an end of the body adjacent the cartridge receptacle. A battery is disposed in the internal cavity. A cartridge includes a housing and a mouthpiece positioned adjacent the housing. The mouthpiece includes a male structure. The female structure receives the male structure when the housing of the cartridge is received within the cartridge receptacle to laterally support the cartridge within the cartridge receptacle.

[0007] In accordance with a fourth example, a vaporization device includes a body having a first end, a second end, and forming an internal cavity. At least a portion of the internal cavity forms a cartridge receptacle. A battery is disposed within the internal cavity. A processor is operatively coupled to the battery and disposed within the body. The processor is arranged to respond to a signal to switch the vaporization device between a first operational mode and a second operational mode. A portion of the body is arranged to permit transmission of the signal through the portion of the body from a location external to the body, thereby permitting the processor to switch the vaporization device between the first and second operational modes in response to the receipt of the signal.

[0008] In further accordance with the foregoing first, second, third and/or fourth examples, an apparatus and/or method may further include any one or more of the following:

[0009] In accordance with one example, the processor is arranged to respond to an activation code carried by the signal.

[0010] In accordance with another example, the first operational mode is an inoperable mode and the second operational mode is an operable mode.

[0011] In accordance with another example, either of the first or second operational modes includes a power mode, a sensitivity mode, or a use mode.

[0012] In accordance with another example, further including a receiver operatively coupled to the processor, the receiver arranged to receive the signal through the portion of the body and to communicate the signal to the processor.

[0013] In accordance with another example, the body includes a first material and the portion of the body is formed of a second material different than the first material, the second material selected to permit passage of the signal through the portion of the body.

[0014] In accordance with another example, the portion of the body includes an opening to permit passage of the signal through the portion of the body.

[0015] In accordance with another example, further including a cover disposed over the opening, the cover formed of a material selected to permit passage of the signal through the opening.

[0016] In accordance with another example, the cover material includes plastic.

[0017] In accordance with another example, further including an illumination assembly arranged to display a light signal.

[0018] In accordance with another example, the illumination assembly is disposed inside the body and the light signal is transmitted through a second portion of the body.

[0019] In accordance with another example, the second portion of the body is translucent.

[0020] In accordance with another example, further including an illumination assembly arranged to display a first light signal indicative of a first status and a second light signal indicative of a second status.

[0021] In accordance with another example, the first status is indicative of the first operational mode and the second status is indicative of the second operational mode.

[0022] In accordance with another example, the illumination assembly is arranged such that the first light signal is a first color and the second light signal is a second color different from the first color.

[0023] In accordance with another example, the external signal carries an authentication code.

[0024] In accordance with another example, the body is formed of a first material that inhibits passage of the external or response signals through portions of the body formed of the first material, and the portion of the body is formed of a second material that allows passage of the external or response signals through the portion of the body.

[0025] In accordance with another example, the first material includes a metal, and the second material includes a plastic.

[0026] In accordance with another example, further including a server, the server is arranged to access identifying information from the mobile device, in response to the identifying information matching reference identifying information, the processor provides an authentication code accessible by the mobile device, the authentication code to be provided to the processor via the external signal.

[0027] In accordance with another example, the female structure includes a notch and the male structure includes a protrusion of the mouthpiece.

[0028] In accordance with another example, the body includes a metal body having an opening, the vaporization device further including a cover covering the opening and includes a material different from the metal body, the material capable of permitting transmission of a signal through the cover.

BRIEF DESCRIPTION OF THE DRAWINGS

[0029] FIG. 1 is a plan view of a vaporization device, partly in schematic form, and assembled in accordance with a disclosed example of the present invention and shown with a removable cartridge having a mouthpiece attached to a body portion; the vaporization device is shown in conjunction with an exemplary system for generating and conveying a signal to and/or from the device from a mobile device.

[0030] FIG. 2A is a plan view of a cartridge shown partially detached from the body of the vaporization device.

[0031] FIG. 2B is a plan view showing the cartridge secured to the vaporization device.

[0032] FIG. 3 is an enlarged isometric view of the removable cartridge of FIG. 1.

[0033] FIG. 4 is an isometric view of a body of the vaporization device separated from the cartridge and with an associated cover spaced from the body.

[0034] FIG. 5 is an end view of the body of the vaporization device of FIG. 4 with the covers removed.

[0035] FIG. 6 is an enlarged cross-sectional view of the body of the vaporization device separated from the cartridge.

DETAILED DESCRIPTION

[0036] Although the following text discloses a detailed description of one or more disclosed examples, it should be understood that the legal scope of the property right is defined by the words of the claims set forth at the end of this patent. Accordingly, the following detailed description is to be construed as illustrating examples, but does not describe every possible example, as describing every possible example would be impractical, if not impossible. Numerous alternative examples could be implemented, using either current technology or technology developed after the filing date of this patent. It is envisioned that such alternative examples would still fall within the scope of the claims.

[0037] Referring now to the drawings, FIG. 1 shows a vaporization device **100** assembled in accordance with the teachings of a first disclosed example of the present invention. The vaporization device **100** is shown as part of a system **101** that includes the vaporization device **100**, a device **102**, and an exemplary server **104**. The device **102** may be, for example, a mobile device such as a cell phone, a smart device such as a smart watch, a computer, a tablet, or any other device suitable for communicating with the vaporization device **100**. Alternatively, the device **102** may be a beacon (e.g., a low-powered transmitter).

[0038] The vaporization device **100** includes a body **106** having a first end **108**, a second end **110**, and forms an internal cavity **112**. A portion **114** of the internal cavity **112** (the portion **114** is best visible in FIG. 6) forms a cartridge receptacle **116** for receiving a removable cartridge **118**. The cartridge **118**, as would be known to those of skill in the art, includes a mouthpiece **120** and a storage container **122** for storing a quantity of a vaporizable medium which is typically in liquid form. The vaporizable medium may include, for example, a nicotine liquid as commonly employed in the art, although the medium may also include or consist of a botanical essence, a flavor, or any other vaporizable medium of the type commonly employed in the art. The cartridge **118** also includes a heating element **124** which, as is discussed below, operates to heat and thus vaporize a quantity of the vaporizable medium.

[0039] A battery **126** is disposed in the internal cavity **112** in any suitable manner. The battery **126** may be of the type commonly employed in the art and may be removable and/or rechargeable. The heating element **124** and the battery **126** are operatively coupled to one another when the cartridge **118** is attached to the body **106**. Typically, a portion **128** (See FIG. 3) of the cartridge **118** extends into the cartridge receptacle **116** when the cartridge **118** is secured to the body **106**. As is well known to those of skill in the relevant art, the heating element **124** is arranged to apply heat to and thus

vaporize a quantity of the vaporizable medium from the storage container 122 of the cartridge 118. As would also be known, the heating element 124 is typically activated when a user, via the mouthpiece 120, draws air that enters through a suitable vent 130 (See. FIG. 3), and flows through the vaporization device 100. Consequently, as would be known, the activated heating element 124 vaporizes the vaporizable medium in the storage container 122, allowing the vapor (typically mixed with air) to be drawn out of the mouthpiece 120 for inhalation by the user.

[0040] The vaporization device 100 also includes a processor 132 that is disposed within the body 106 and that is operatively coupled to the battery 126 in any suitable fashion. In operation, the processor 132 is arranged to respond to a signal 134 from, for example, the device 102, such that receipt of the signal 134 by the processor 132 causes the vaporization device 100 to switch between a first operational mode and a second operational mode. In the example shown, the signal 134 is an external signal which is generated from outside of the vaporization device 100. In one exemplary mode of operation, when in the first operational mode, the vaporization device 100 is prevented from operating and/or is turned off, and while when in the second operational mode, the operation of the vaporization device 100 is enabled and/or turned on.

[0041] A portion 136 of the body 106 is arranged to permit transmission of the signal 134 from a location external to the body 106 through the portion 136 of the body 106. In the example of FIG. 1, the signal 134 emanates from the device 102, with the signal 134 traveling through the portion 136 of the body 106 to subsequently be received directly or indirectly by the processor 132. The signal 134 can carry an activation code or another command that can be executed by the processor 132. Therefore, receipt of the signal 134 triggers the processor 132 to switch the vaporization device 100 between the first and second operational modes. The first operational mode can be an inoperable mode and the second operational mode can be an operational mode. Alternatively, the first and second operational modes can relate to a power mode, a sensitivity mode or a user mode.

[0042] In the example shown, the vaporization device 100 includes a receiver 137, which receives the signal 134 and communicates information in the signal 134 (e.g., the activation code) to the processor 132. The receiver 137 may include any type of communication interface (e.g. a wireless interface) configured to operate in accordance with any suitable protocol(s). For example, the receiver 137 may be configured to communicate using near field communication (NFC), remote communication, Bluetooth®, an audio signal and/or a voice input. The receiver 137 may also be configured to receive a signal via a dongle (e.g., a micro USB). The signal received via the dongle may carry an activation code or another command that can be executed by the processor 132. Therefore, receipt of the signal via the dongle can trigger the processor 132 to switch the vaporization device 100 between the first and second operational modes.

[0043] The receiver 137 of the vaporization device 100 may be a transceiver 138, thus enabling the vaporization device 100 to communicate a response signal 139 from the vaporization device 100 back to the device 102. The response signal 139 may carry information associated with a status of the vaporization device 100. Alternatively, the

vaporization device 100 may include a separate transmitter 140 separate from the receiver 137 and operatively coupled to the processor 132.

[0044] Referring still to FIG. 1, the portion 136 of the body 106 allows the signal 134 to travel from the device 102 to the receiver 137 or the transceiver 138, and thus be communicated to the processor 132. The portion 136 also allows the response signal 139 to travel from the transceiver 138 or the transmitter 140 to the device 102. In one exemplary form, the body 106 is formed of a first material that does not allow, or is otherwise resistant to or inhibits, the passage of the signal 134 through those parts of the body 106 that are constructed of the first material. On the other hand, the portion 136 of the body 106 may be formed of a second material that does allow the passage of the signal 134 through the portion 136 of the body. As an example, the first material may be metal, and the second material may be a plastic, a ceramic, or a non-metal material. Still other materials may prove suitable for both the body 106 and the portion 136 of the body 106.

[0045] In another exemplary form, the portion 136 of the body 106 may be an opening 141 in a surface 142 of the body 106 (the surface 142 is best visible in FIG. 4), and thus the opening 141 allows passage of the signal 134 through to an interior of the body 106, to the receiver 137 or transceiver 138, and ultimately for communication to the processor 132. The opening 141 may be formed in any suitable fashion. For example, the opening 141 may be one or more slits or one or more other suitable apertures in the surface 142 of the body 106. The opening 141 and/or the portion 136 may be formed at the ends 108, 110 of the body 106. Thus, the portion 136 may be formed within the cartridge receptacle 116 and the signal 134 may be received through the portion 136 when the cartridge 118 is received within the cartridge receptacle 116 or when the cartridge 118 is not received within the cartridge receptacle 116.

[0046] Additionally, the opening 141 may be covered by a cover 144, with the cover 144 being disposed or removably disposed over the opening 141 in any suitable fashion. In the example of FIG. 1, the cover 144 includes a first end 146 disposed adjacent the first end 108 of the body 106, a second end 148 disposed adjacent the second end 110 of the body 106, and a pair of elongated sides 150 and 152. The cover 144 is sized to be disposed in an elongated recess 154 formed by the surface 142 of the body 106 (the elongated recess 154 is best visible in FIGS. 4 and 5). The cover 144 can be formed of plastic or another suitable material.

[0047] Referring still to FIG. 1, the vaporization device 100 may include an illumination assembly 156 which is operatively coupled to the processor 132 and the battery 126. In the disclosed example, the illumination assembly 156 is arranged to display a light signal or a plurality of light signals which may be indicative of a first status, a second status, or more states. For example, the illumination assembly 156 may display no light signal when the vaporization device 100 is in a first state such as the inoperable mode, and may display a light signal when the vaporization device 100 is in a second state such as the operable mode. Light signals may also be used to indicate the status of the vaporization device 100. For example, a first light signal may be used to indicate an amount of power remaining in the battery 126, a second light signal may be used to indicate an amount of liquid remaining in the storage container 122 of the cartridge 118 and a third light signal may be used to indicate a status

of the heating element **124** being activated/energized. The first signal may be a first color (e.g., green), the second signal is a second color (e.g., blue) and the third signal may be a third color (e.g., red). However, additional signals may be displayed using different colors. Still further, the illumination assembly **156** may display a first color light signal when the vaporization device **100** is in the inoperable mode, and may display a second and different color light signal when the vaporization device **100** is in the operable mode.

[0048] As another example, the illumination assembly **156** may display a first light signal in the form of a graphical character, such as a negative sign or the like, when the vaporization device **100** is in an inoperable mode, and may display a second and different light signal, such as a positive sign, when the vaporization device **100** is in the operable mode. In the example of FIG. 1, the illumination assembly **156** is placed beneath the cover **144**, and the cover **144** includes a portion **158** that is transparent or translucent to allow the light signal, in whatever form, if illuminated, to be visible by a user. The portion **158** may be a transparent or translucent disc, or any other suitable structure. Preferably, the portion **158** can provide light-softening characteristics. In the example shown, the portion **158** includes an O-ring.

[0049] Referring again to FIG. 1, the vaporization device **100** includes a memory **164**. The memory **164** can store an authentication code, commands or reference temperatures or any other data relating to the vaporization device **100**. The authentication code can be executed by the processor **132** in response to the processor **132** determining to switch the vaporization device **100** from the first operation mode to the second operation mode.

[0050] As an example, when the vaporization device **100** is purchased by a consumer, the vaporization device **100** is in a first operational mode. The first operational mode may prevent the vaporization device **100** from being used or may prevent a feature of the vaporization device **100** from being used. The feature may be associated with a setting of the heating element **124**.

[0051] As an alternative example, when the vaporization device **100** is purchased, the vaporization device **100** is in a second operational mode. In the second operational mode, the vaporization device **100** can be used for vaping, for example. However, after an event occurs, the processor **132** may switch the vaporization device **100** from the second operational mode to the first operational mode. The event may be associated with an amount of time lapsing or the vaporization device **100** being used a particular number of times.

[0052] To activate the vaporization device **100**, the device **102** obtains an authentication code from the server **104**. To do so, the server **104** is arranged to access identifying information from the device **102** via a signal **165**. The identifying information may include an identifier associated with the vaporization device **100** and authenticating information from the consumer. The identifier may be a serial number/product code provided with the vaporization device **100** and the authenticating information may include age identifying information such as a name, a social security number, a driver's license number, age, an address, etc.

[0053] To authenticate the consumer and data provided, the server **104** includes a processor **166** and a memory **168**. During the authentication process, the processor **166** compares the authentication data to reference authentication data stored at the memory **168**. If the authentication data does not

match the reference authentication data at the server **104** or if the processor **166** does not otherwise authenticate the consumer, the processor **166** can generate an alert (e.g., an error message). The alert may be provided to the device **102** via the signal **165**. The alert may indicate that the vaporization device **100** cannot be activated at this time because the user information provided is not associated with an individual of legal age (e.g., 18-years old; 21-years old, etc.) to use the vaporization device **100** and/or that the consumer is not authenticated to use the vaporization device **100**.

[0054] However, if the authentication data matches the reference authentication data or if the processor **166** otherwise authenticates the consumer, the processor **166** identifies an authentication code associated with the vaporization device **100** and provides the authentication code to the device **102** via the signal **165**. Different authentication codes may be provided to different vaporization devices to change the device from a first operational mode to a second operational mode in which the vaporization device **100** is operable or the feature is unlocked. Alternatively, the same authentication code can be provided to different vaporization devices to change the device from a first operational mode to a second operational mode. The authentication code may be and/or may be referred to as a digital token, a code, a key, a sequence or an audio key.

[0055] To activate the vaporization device **100**, the device **102** transmits the signal **134** through the cover **144** and the opening **141**. The signal **134** is accessed by the receiver **137** and provided to the processor **132**. The processor **132** compares the activation code to a reference activation code stored at the memory **164** of the vaporization device **100**. In response to the activation code matching the reference activation code, the processor **132** accesses and executes an activation command to enable a capability of the vaporization device **100**. Once the capability is enabled, the vaporization device **100** can be used for vaping, for example. The activation command may be stored at the memory **164**.

[0056] Referring now to FIG. 2A, the cartridge **118** is shown partially received within the cartridge receptacle **116**. The vaporization device **100** includes a lateral support assembly **159**. In the example shown, the lateral support assembly **159** includes a male structure formed by a protrusion **160** carried by the cartridge **118** and a female structure formed by a cooperating notch **162** that is carried by or formed by the body **106**. The protrusion **160** is rectangularly shaped and includes a pair of sides **160a** and **160b** and an end **160c**. The notch **162** has a corresponding rectangular shape and includes a pair of sides **162a** and **162b** and an end **162c**. Alternatively, the protrusion **160** can be carried by the body **106** and the notch **162** can be formed by the mouthpiece **120**. While the protrusion **160** and the notch **162** are shown being rectangular, the protrusion **160** and the notch **162** can be any other corresponding shape. For example, the protrusion **160** and the notch **162** can be triangular, have rounded ends or be another corresponding male/female structure.

[0057] Referring to FIG. 2B, the protrusion **160** is shown received within the notch **162**. In the disclosed example, as the cartridge **118** is inserted into the cartridge receptacle **116**, the sides **162a**, **162b** of the notch **162** engage or otherwise interact with corresponding sides **160a**, **160b** of the protrusion **160**, guiding the cartridge **118** into the cartridge receptacle **116**. Additionally, in accordance with the disclosed example, when the cartridge **118** is received within the

cartridge receptacle **116** and the protrusion **160** is received within the notch **162**, an engagement between or a proximity of the corresponding sides **160a**, **160b**, **162a**, **162b** and the ends **160c**, **162c** increases the lateral stability of the cartridge **118** within the cartridge receptacle **116**.

[0058] Referring to FIG. 3, an enlarged isometric view of the cartridge **118** is shown. The mouthpiece **120** is shown positioned adjacent a top surface **174** of a housing **175** of the cartridge **118** and coupled thereto using a snapfit connection.

[0059] Referring to FIG. 4, the cover **144** is shown removed from the body **106** and the cartridge **118** is separated from the cartridge receptacle **116**. Without the cover **144** covering the surface **142**, the opening **141** through the surface **142** of the body **106** and the elongated recess **154** and the notch **162** are more clearly shown. The elongated recess **154** includes a pair of sides **154a** and **154b** and a curved end **154c**. In the disclosed example, the elongated recess **154** is sized to receive the cover **144** such that adjacent surfaces **176a**, **176b** of the cover **144** and the body **106**, respectively, are substantially flush when the cover **144** is received within the elongated recess **154**.

[0060] Referring to FIG. 5, an end view of the body **106** with the cover **144** removed is shown illustrating another view of the elongated recess **154**. In the example shown, the body **106** includes opposing elongated recesses **154** that receive the cover **144**. FIG. 5 also shows that the vaporization device **100** includes contacts **177**, **178**, a magnet **180** and a nozzle **182**. Details of these components are further described in FIG. 6.

[0061] Referring to FIG. 6, a cross-sectional view of the body **106** of the vaporization device **100** is shown illustrating the internal cavity **112**, the cartridge receptacle **116**, the battery **126** and a universal serial bus (USB) port **184**. The USB port **184** is operatively coupled to the processor **132** and the battery **126**.

[0062] The cross-sectional view also shows a support **185** disposed within the internal cavity **112**. The support **185** includes a cavity **186**, the nozzle **182** and a recess **190**. The nozzle **182** extends into the cartridge receptacle **116** and is in fluid communication with a sensor **191**. The recess **190** faces the cartridge receptacle **116** and receives the magnet **180**. The magnet **180** can be used to retain the cartridge **118** within the cartridge receptacle **116**. Thus, the cartridge **118** can be releasably but securely held within the cartridge receptacle **116** via the magnet **180**. Alternatively, the cartridge **118** can be coupled within the cartridge receptacle **116** via an interference fit or a snap-fit connection. The contacts **177**, **178** that are coupled to the battery **126** extend through the support **185** and are used to provide power to the heating element **124**.

[0063] From the foregoing, it will be appreciated that the above disclosed apparatus, methods and articles of manufacture relate to metal-bodied vaporization devices to

receive and/or transmit data. In some examples, the data received at the vaporization device is associated with a command. Some of those commands may include an authentication command that enables usage of the vaporization device. Others of the commands may include a capability enablement command that allows a particular capability to be activated. Regardless of the type of data transmitted, the metal-bodied vaporization devices disclosed herein allow communication to occur that would otherwise not be feasible given the signal transmission characteristics of the metal-bodied devices.

[0064] Further, while several examples have been disclosed herein, any features from any examples may be combined with or replaced by other features from other examples. Moreover, while several examples have been disclosed herein, changes may be made to the disclosed examples without departing from the scope of the claims.

1. A method of communicating between a vaporization device and a mobile device, the method comprising:

establishing wireless communication between the mobile device and the vaporization device, the vaporization device including a body having a cartridge receptacle and an opening, and a cover covering the opening;

generating, by a processor of the vaporization device, information associated with a status of the vaporization device; and

transmitting a signal to the mobile device from the vaporization device through the cover and the opening of the vaporization device, the signal carrying the information associated with the status of the vaporization device.

2. The method of claim 1, further comprising receiving a second signal from the mobile device through the opening of the vaporization device; and accessing the second signal at the processor of the vaporization device.

3. The method of claim 2, wherein in response to accessing the second signal, further comprising switching, by the processor, the vaporization device from a first operational mode to a second operational mode.

4. The method of claim 1, wherein the opening is spaced from the cartridge receptacle.

5. The method of claim 1, wherein the opening is spaced from an end of the vaporization device opposite the cartridge receptacle.

6. The method of claim 1, wherein the opening is formed at an end of the body.

7. The method of claim 1, wherein the opening is formed within the cartridge receptacle.

8. The method of claim 1, further comprising a second cover and wherein the body includes a second opening opposite the opening and covered by the second cover.

* * * * *