



INTERNATIONAL APPLICATION PUBLISHED UNDER THE PATENT COOPERATION TREATY (PCT)

<p>(51) International Patent Classification <sup>6</sup> : <b>A61F 2/02</b></p>	<p><b>A1</b></p>	<p>(11) International Publication Number: <b>WO 96/14807</b> (43) International Publication Date: 23 May 1996 (23.05.96)</p>
<p>(21) International Application Number: PCT/US95/04236 (22) International Filing Date: 4 April 1995 (04.04.95) (30) Priority Data: 08/341,881 15 November 1994 (15.11.94) US (71) Applicant: SISTERS OF PROVIDENCE IN OREGON [US/US]; 520 Pike Street, P.O. Box 11038, Seattle, WA 98111-9038 (US). (71)(72) Applicant and Inventor: GREGORY, Kenton, W. [US/US]; 23200 Stafford Hill Drive, West Linn, OR 97068 (US). (72) Inventor: GRUNKEMEIER, John; 6537 Sunnyside Avenue N., Seattle, WA 98103 (US). (74) Agents: MARGER, Jerome, S. et al.; Marger, Johnson, McCollom &amp; Stolowitz, P.C., Suite 650, 621 S.W. Morrison Street, Portland, OR 97205 (US).</p>		<p>(81) Designated States: AU, BR, CA, CN, JP, KR, MX, SG, European patent (AT, BE, CH, DE, DK, ES, FR, GB, GR, IE, IT, LU, MC, NL, PT, SE).  <b>Published</b> <i>With international search report.</i></p>

(54) Title: ELASTIN, AND ELASTIN-BASED BIOMATERIALS AND PROCESS

(57) Abstract

The present invention relates to an elastin-based biomaterial and to a method of using same to effect tissue repair or replacement. The invention further relates to a method of securing the biomaterial to existing tissue.

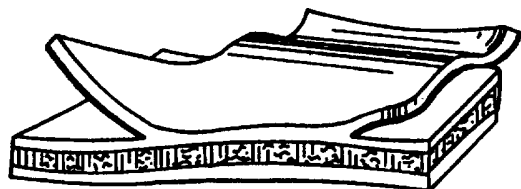
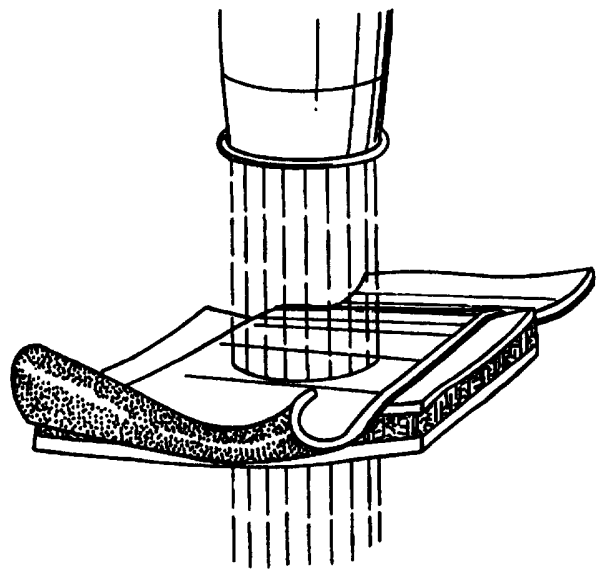

**FOR THE PURPOSES OF INFORMATION ONLY**

Codes used to identify States party to the PCT on the front pages of pamphlets publishing international applications under the PCT.

AT	Austria	GB	United Kingdom	MR	Mauritania
AU	Australia	GE	Georgia	MW	Malawi
BB	Barbados	GN	Guinea	NE	Niger
BE	Belgium	GR	Greece	NL	Netherlands
BF	Burkina Faso	HU	Hungary	NO	Norway
BG	Bulgaria	IE	Ireland	NZ	New Zealand
BJ	Benin	IT	Italy	PL	Poland
BR	Brazil	JP	Japan	PT	Portugal
BY	Belarus	KE	Kenya	RO	Romania
CA	Canada	KG	Kyrgystan	RU	Russian Federation
CF	Central African Republic	KP	Democratic People's Republic of Korea	SD	Sudan
CG	Congo	KR	Republic of Korea	SE	Sweden
CH	Switzerland	KZ	Kazakhstan	SI	Slovenia
CI	Côte d'Ivoire	LI	Liechtenstein	SK	Slovakia
CM	Cameroon	LK	Sri Lanka	SN	Senegal
CN	China	LU	Luxembourg	TD	Chad
CS	Czechoslovakia	LV	Latvia	TG	Togo
CZ	Czech Republic	MC	Monaco	TJ	Tajikistan
DE	Germany	MD	Republic of Moldova	TT	Trinidad and Tobago
DK	Denmark	MG	Madagascar	UA	Ukraine
ES	Spain	ML	Mali	US	United States of America
FI	Finland	MN	Mongolia	UZ	Uzbekistan
FR	France			VN	Viet Nam
GA	Gabon				

## ELASTIN, AND ELASTIN BASED BIO-MATERIALS AND PROCESS

## TECHNICAL FIELD

5           The present invention relates to elastin and  
elastin-based biomaterials and to methods of using same  
in tissue repair and replacement. The invention further  
relates to methods of securing the elastin and elastin-  
based biomaterials to existing tissue.

10

## BACKGROUND OF THE INVENTION

Elastin is an extracellular matrix protein that is  
ubiquitous in mammals. Elastin is found, for example,  
in skin, blood vessels, and tissues of the lung where it  
imparts strength, elasticity and flexibility. In  
15           addition, elastin, which is prevalent in the internal  
elastic lamina (IEL) and external elastic lamina (EEL)  
of the normal artery, may inhibit the migration of  
smooth muscle cells into the intima. Elastin in the  
20           form of solubilized peptides has been shown to inhibit  
the migration of smooth muscle cells in response to  
platelet-derived factors (Ooyama et al, Arteriosclerosis  
7:593 (1987)). Elastin repeat hexapeptides attract  
bovine aortic endothelial cells (Long et al, J. Cell.  
25           Physiol. 140:512 (1989)) and elastin nonapeptides have  
been shown to attract fibroblasts (USP 4,976,734). The  
present invention takes advantage of these physical and  
biochemical properties of elastin.

Thirty to forty percent of atherosclerotic stenoses that are opened with balloon angioplasty restenose as a result of ingrowth of medial cells. Smooth muscle ingrowth into the intima appears to be more prevalent in sections of the artery where the IEL of the artery is 5 ripped, torn, or missing, as in severe dilatation injury from balloon angioplasty, vessel anastomoses, or other vessel trauma that results in tearing or removal of the elastic lamina. While repair of the arterial wall 10 occurs following injury, the elastin structures IEL and EEL do not reorganize. Since these components play major structural and regulatory roles, their destruction is accompanied by muscle cell migration.

There are also diseases that are associated with 15 weakness in the vessel wall that result in aneurysms that can ultimately rupture, as well as other events that are, at least in part, related to abnormalities of elastin.

Prosthetic devices, such as vascular stents, have 20 been used with some success to overcome the problems of restenosis or re-narrowing of the vessel wall resulting from ingrowth of muscle cells following injury. However, their use is often associated with thrombosis. In addition, prosthetic devices can exacerbate underlying 25 atherosclerosis. Nonetheless, prostheses are often used.

Until relatively recently, the primary methods available for securing a prosthetic material to tissue (or tissue to tissue) involved the use of sutures or

staples. Fibrin glue, a fibrin polymer polymerized with thrombin, has also been used (primarily in Europe) as a tissue sealant and hemostatic agent.

5 Laser energy has been shown to be effective in tissue welding arterial incisions, which is thought to occur through thermal melting of fibrin, collagen and other proteins. The use of photosensitizing dyes enhances the selective delivery of the laser energy to the target site and permits the use of lower power laser  
10 systems, both of which factors reduce the extent of undesirable thermal trauma.

The present invention combines the advantages of elastin-based products with the advantages of laser welding techniques, and provides a unique method of  
15 tissue repair and replacement. The invention makes possible tissue prostheses (particularly, vascular prostheses) that are essentially free of problems associated with prostheses known in the art.

#### 20 OBJECTS AND SUMMARY OF THE INVENTION

It is a general object of the invention to provide a method of effecting tissue repair or replacement.

It is a specific object of the invention to provide an elastin or elastin-based biomaterial suitable for use  
25 as a stent, for example, a vascular stent, or as conduit replacement, for example, as an artery, vein or a ureter replacement. The biomaterial can also be used as a stent or conduit covering or lining.

It is a further object of the invention to provide an elastin or elastin-based graft suitable for use in repairing a lumen wall.

5 It is another object of the invention to provide an elastin or elastin-based material suitable for use in tissue replacement or repair, for example, in interior bladder replacement or repair, in intestine, esophagus or colon repair or replacement, or skin repair or replacement.

10 It is also an object of the invention to provide a method of securing an elastin or elastin-based biomaterial to an existing tissue without the use of sutures or staples.

15 The present invention relates to a method of repairing, replacing or supporting a section of a body tissue. The method comprises positioning an elastin or elastin based biomaterial at the site of the section and bonding the biomaterial to the site or to the tissue surrounding the site. The bonding is effected by  
20 contacting the biomaterial and the site, or tissue surrounding the site, at the point at which said bonding is to be effected, with an energy absorbing agent. The agent is then exposed to an amount of energy absorbable by the agent sufficient to bond the biomaterial to the  
25 site or to the tissue surrounding the site.

More specifically, a tissue-fusible elastin or elastin-based biomaterial can be produced using the process of the present invention which comprises a layer of elastin or elastin-based biomaterial and a tissue

substrate each having first and second outer surfaces; and an energy absorbing material applied to at least one of the outer surfaces, the energy absorbing material penetrates into the biomaterial.

5           The energy absorbing material is energy absorptive within a predetermined range of light wavelengths. The energy absorbing material is chosen so that when it is irradiated with light energy in the predetermined  
10           wavelength range, the intensity of that light will be sufficient to fuse together one of the first and second outer surfaces of the elastin or elastin-based biomaterial and the tissue substrate. Preferably, the first and second outer surfaces of the elastin or elastin-based biomaterial are major surfaces.  
15           Typically, the energy absorbing material is indirectly irradiated by directing the light energy first through the elastin or elastin-based biomaterial or tissue substrate and then to the energy absorbing material.

20           In a preferred process of this invention, the energy absorbing material comprises a biocompatible chromophore, more preferably an energy absorbing dye. In one form of the present invention, the energy absorbing material is substantially dissipated when the elastin or elastin-based biomaterial and the tissue  
25           substrate are fused together. In another form of this invention, the energy absorbing material comprises a material for staining the first or second surface of the elastin or elastin-based biomaterial.

The energy absorbing material can also be applied to one of the outer surfaces of the biomaterial by doping a separate elastin layer with an energy absorbing material and then fusing the doped separate elastin layer to the elastin or elastin-based elastin. In any case, the energy absorbing layer is preferably substantially uniformly applied to at least one of the outer surfaces, typically in a manner wherein the energy absorbing material substantially covers the entire outer surface of the elastin or elastin-based biomaterial.

Some of the key properties which effect the process of the present invention regarding fusing the elastin or elastin-based biomaterial and tissue substrate include the magnitude of the wave length, energy level, absorption, and light intensity during irradiation with light energy of the energy absorbing material, and the concentration of the energy absorbing material. These properties are arranged so that the temperature during irradiation with light energy for period of time which will cause fusing together of one of the first and second outer surfaces of the elastin or elastin-based biomaterial and the tissue substrate is from about 40 to 140 degrees C., and more preferably from about 50 to 100 degrees C. Furthermore, the average thickness of the energy absorbing material in the preferred process of this invention is from about 0.5 to 300 microns.

Further objects and advantages of the invention will be clear from the description that follows.



## BRIEF DESCRIPTION OF THE DRAWINGS

FIGURE 1 Application of laser energy to biomaterial and exposed native tissue.

5 FIGURE 2 Placement of elastin biomaterial into artery.

FIGURE 3. Use of biomaterial as intestinal patch.

10 FIGURE 4. Scanning electron micrograph of elastin-based biomaterial (prepared according to Rabaud et al using elastin, fibrinogen and thrombin) fused to porcine aorta using continuous wave diode laser.

FIGURE 5. Light microscopic picture of elastin-based biomaterial fused to porcine aorta using a pulsed diode laser. E = elastin biomaterial; A = aorta.

15 FIGURE 6. Light microscopic photomicrograph of elastin-based biomaterial derived from arterial digest welded to porcine carotid artery. E = elastin biomaterial; A = aorta.

20 DETAILED DESCRIPTION OF THE INVENTION

The present invention relates to elastin-based biomaterials and to methods welding of such biomaterials to tissue using laser energy. Elastin-based biomaterials suitable for use in the present invention can be prepared, for example, from elastin (eg from 25 bovine nuchal ligament), fibrinogen and thrombin as described by Rabaud et al (USP 5,223,420). (See also Aprahamian et al, J. Biomed. Mat. Res. 21:965 (1987); Rabaud et al, Thromb. Res. 43:205 (1986); Martin,

Biomaterials 9:519 (1988).) Such biomaterials can have associated thrombogenic property that can be advantageous in certain types of tissue repair.

Elastin-based biomaterials suitable for use in the invention can also be prepared from elastin and type III collagen, also as described by Rabaud and co-workers (Lefebvre et al, Biomaterials 13(1):28-33 (1992)). Such preparations are not thrombogenic and thus can be used for vascular stents, etc. A further type of

elastin-based biomaterial suitable for use in the present invention is prepared as described by Urry et al (see, for example, USP 4,132,746 and 4,500,700) (See also USP's 4,187,852, 4,589,882, 4,693,718, 4,783,523, 4,870,055, 5,064,430, 5,336,256). Elastin matrices resulting from digestion of elastin-containing tissues (eg arteries) can also be used. Digestion results in the removal of cells, proteins and fats but maintenance of the intact elastin matrix. The biomaterial used will depend on the particular application.

Elastin-based biomaterial of the invention prepared from soluble elastin (see Rabaud et al. above) can be molded so as to render it a suitable size and shape for any specific purpose. Molded biomaterial can be prepared as follows. Elastin (eg soluble elastin (MW 12-32,000 daltons) is washed and swollen in buffer. Fibrinogen or cryoglobulins (prepared, for example, according to Pool et al, New Engl. J. Med. 273 (1965) are added to the swollen elastin, followed by thiourea, with or without a protease inhibitor (such as aprotinin), and

collagen. Thrombin is added with stirring and the resulting mixture is immediately poured into an appropriate mold. The mold is then incubated (for example, at 37°C) while polymerization of the  
5 fibrin/elastin material is allowed to proceed, advantageously, for from between 15 minutes to 1 hour, 30 minutes being preferred. The reaction can be carried out at temperatures less than 37°C., but the reaction proceeds more rapidly at 77°C. Heating the reaction to  
10 over 40°C, however, can result in denaturation of the thrombin. Cooling of the mixture while stirring allows more time for mixing to occur. For polymerization to occur, it is important to have calcium and magnesium in the buffer and to use undenatured thrombin.

15 Following polymerization in the mold, the resulting biomaterial can be further cross-linked using gamma radiation or an agent such as glutaraldehyde (a solution of glutaraldehyde, formic acid and picric acid being preferred). When radiation is used, the samples are,  
20 advantageously, subjected to gamma-irradiation from a Cobalt-60 source. The amount of irradiation can range, for example, from 10 to 100MRAD, with 25MRAD being preferred. It has been shown that the amount of gamma-irradiation can affect the strength of the  
25 material (Aprahamian, J. Biomed. Mat. Res. 21:965 (1987)).

Sheets of biomaterial can be prepared that are of a controlled thicknesses by using appropriate molds. Sheets of the biomaterial can be made in thicknesses

ranging, for example, from 200 microns to 5 mm. Sheets are generally made as thin as possible to allow for penetration of laser energy while maintaining sufficient strength. By way of example, a sheet suitable for use as an intestinal patch can range in thickness from 200 microns to 5 mm, with about 2 mm being preferred. A patch requiring greater strength, such a patch for use in the bladder, is typically thicker. Arterial stents or patches can be thinner (eg 100  $\mu\text{m}$  - 1000  $\mu\text{m}$ ).

Biomaterial prepared from soluble elastic or insoluble elastin fragments can also be molded into tubular segments for example, by injecting the material into tubular molds. Crosslinkage of the elastin solution present between the inner and outer tubes can be effected prior to withdrawal of biomaterial from the mold or after the tubes are removed. Tubular segments of different inner and outer diameters, as well as of different lengths, can be prepared using this approach by varying the diameters of the inner and outer tubes. A mold of this type can be made in virtually any size with the inner and outer tubes varying in diameter. A small tube can be used for a coronary arterial stent. A large tube of 1-5 inches in diameter can be made and used as an angularly welded patch for anastomosis of the small intestine or colon. Various molding techniques and molding materials can be used; the foregoing is merely an example.

As indicated above, biomaterial suitable for use in the present invention can be prepared from digests of

tissue containing an elastin matrix. Tissues suitable for use as a starting material include arteries (e.g. coronary or femoral arteries, for example, from swine), umbilical cords, intestines, ureters, etc. Preferably, the matrix material is (derived from the species of animal in which the implantation is being performed so that biocompatibility is increased. Any method of removing (digesting away) cellular material, proteins and fats from the native matrix while leaving the extracellular elastin matrix intact can be used. These methods can involve a combination of acidic, basic, detergent, enzymatic, thermal or erosive means, as well as the use of organic solvents. This may include incubation in solutions of sodium hydroxide, formic acid, trypsin, guanidine, ethanol, diethylether, acetone, t-butanol, and sonication. Typically, the digestion proceeds more quickly at higher temperatures. The optimal temperature and time (of incubation depend on the starting material and digestive agent used, and can be readily determined.

One skilled in the art will appreciate that while tubular segments result from digestion of tubular starting materials, those segment can be opened and shaped to yield sheets suitable for use as tissue grafts. Alternatively, such segments can be opened and then reconstructed as tubular segments having a diameter different than the starting tissue. Preferably, however, when tubular products are sought, the starting material is selected so as to yield a tubular segment

after digestion having the appropriate diameter so that subsequent manipulations (other than adjustment of length) can be avoided.

5 The biomaterial of the invention, whether prepared from elastin powder or from tissues digests, is normally secured to existing tissue. Various techniques for effecting that attachment can be used, including art-recognized techniques. However, it is preferred that the biomaterial be secured using a tissue welding energy source and an agent that absorbs energy emitted 10 by that source. Advantageously, the energy source is an electromagnetic energy source, such as a laser, and the absorbing agent is a dye having an absorption peak at a wavelength corresponding to that of the laser. The 15 elastin biomaterial and the tissue to be welded have much less absorption of light at this wavelength and the effect therefore is confined to a zone around the dye layer. A preferred energy source is a laser diode having a dominant wavelength at about 808 nm and a 20 preferred dye is indocyanine green (ICG), maximum absorbance 795-805 nm (see WO 91/((,4073). Other laser/dye combinations can also be used. It is preferred that the dye be applied to that portion of the biomaterial that is to be contacted with and secured to 25 the existing tissue. The dye can also be applied to the surface of the structure to which the elastin biomaterial is to be welded or secured. The dye can be applied directly to the biomaterial or the surface of the biomaterial can first be treated or coated (eg

primed) with a composition that controls absorption of the dye into the biomaterial so that the dye is kept as a discrete layer or coating. Alternatively, the dye can be bound to the elastin biomaterial so that it is secured to the surface and prevented from leeching into the material. The dye can be applied in the form of a solution or the dye can be dissolved in or suspended in a medium which then can be applied as a thin sheet or film, preferably, of uniform thickness and dye concentration.

Tissue welding techniques employing a soldering agent can be used. Such techniques are known (WO 91/04073). Any proteinaceous material that thermally denatures upon heating can be used as the soldering agent (for example, any serum protein such as albumin, fibronectin, Von Willebrand factor, vitronectin, or any mixture of proteins or peptides). Solders comprising thrombin polymerized fibrinogen are preferred, except where such materials would cause undesirable thrombosis or coagulation such as within vascular lumens. Solders are selected for their ability to impart greater adhesive strength between the biomaterial and the tissue. The solder should be non-toxic and generally biocompatible.

In accordance with the present invention, the laser energy can be directed to the target site (eg, the dye) directly from the laser by exposure of the tissue (eg, during a surgical procedures). In some cases, i.e. endovascular catheter-based treatments where open

surgical exposure does not occur, the laser energy is directed to the bonding site via optical fibers. When ICG is used as the dye, targeting media wavelengths of around 800nm can be used. Such wavelengths are not well absorbed by many tissues, particularly vascular tissues, therefore, there will be a negligible effect on these tissues and thermal effects will be confined to the dye layer. The biomaterial of the invention similarly has little optical absorbance in this waveband, as compared to the energy absorbing dye. Thus, the laser energy can pass through either the biomaterial or the native tissue and be absorbed by the dye layer as shown in Figure 1. Once the surgeon has exposed the surface or vessel where the biomaterial reinforcement or replacement is to be effected, the dye-containing surface of the biomaterial is placed in contact with the native tissue at the site and laser energy delivered by directing the laser beam to the desired location. The absorbance of the dye (eg ICG) layer is ideally previously or concurrently determined so that the optimal amount of light for optimal bonding can be delivered. Pressure can be used to ensure adequate approximation of the tissue and biomaterial. With a diode laser source, the diode laser itself, or a condenser or optical fiber based optical delivery system, can be placed against the material to ensure uniform light delivery.

In cases where a new elastin lining or new-internal elastic lamina is required, for example, following an open surgical endarterectomy, once the artery has been



surgically cleared of the atheroma or other lesion, the biomaterial is then put in place, dye side down (see Figure 2). The biomaterial can be deployed as a flat patch or as a tubular segment. A tubular segment can be hollow or filled with a material that supports the lumen during placement and that is melted with low grade heat or dissolved or removed with a variety of means. When necessary, a small number of surgical sutures (eg stay sutures) can be used to appose the edges of the vessel together or to sew the vessel. Once the biomaterial is in place, the laser energy is directed through the vessel wall or through the biomaterial to the absorbing dye, the appropriate laser energy having been previously determined based upon the measured absorbance in the biomaterial. Alternatively, the dye can be applied at the time of the surgery to the biomaterial or the vessel wall or both and then laser energy delivered. In this embodiment, absorbance can be determined at the time of the surgery to the biomaterial or the vessel wall or both and then laser energy delivered or with a feedback device that assesses the adequacy of the bonding or thermal effect. (Figure 4 is a SEM of elastin-based biomaterial fused to porcine aorta.)

In addition to the above, the biomaterial of the invention can be used as a patch material for use in intestinal or colon repairs which frequently do not heal well with current techniques, particularly when the patient has nutritional or other problems or when the patient is in shock, such as in the case of multiple

gunshot wounds or other abdominal injuries (see Figure 3). The use of such a patch can, for example, seal off intestinal contents and thereby reduce the likelihood of peritonitis. In addition, a patch can be used on a solid organ, such as the liver, when lacerations have occurred. Similarly, the biomaterial of the invention can be used to repair or replace portions of the urinary system i.e., from the calyces of the kidney on down to the urethra. The patch can also be used to seal a defect in a cardiac chamber, such as an atrial septal defect, as well as bronchial or rectal fistulas. The biomaterial can also be used as a cerebrovascular patch for an aneurysm. The biomaterial can be sealed in place with targeted laser fusion. For applications where direct exposure is not possible or not desirable, a variety of catheter or endoscopic systems can be employed to direct the laser energy to the target site.

The elastin-based biomaterials to which the invention relates can be used in a variety of other clinical and surgical settings to effect tissue repair graft. For delivery of biomaterial in the form of an intravascular stent, the biomaterial can be pre-mounted upon a deflated balloon catheter. The balloon catheter can be maneuvered into the desired arterial or venous location using standard techniques. The balloon can then be inflated, compressing the stent (biomaterial) against the vessel wall and then laser light delivered through the balloon to seal the stent in place (the dye can be present on the outside of the biomaterial). The

balloon can then be deflated and removed leaving the stent in place. A protective sleeve (eg of plastic) can be used to protect the stent during its passage to the vessel and then withdrawn once the stent is in the  
5 desired location. The biomaterial of the invention can also be used as a biocompatible covering for a metal or synthetic scaffold or stent. In such cases, simple mechanical deployment can be used without the necessity for laser bonding. Laser bonding can be employed,  
10 however, depending upon specific demands, eg, where inadequate mechanical bonding occurs, such as in stent deployment for abdominal aortic aneurysms.

An alternative catheter-based vascular stent deployment strategy employs a temporary mechanical stent  
15 with or without a balloon delivery device.

A further catheter-based vascular stent deployment strategy employs a heat deformable metal (such as nitinol or other similar type metal) scaffold or stent or coating that is incorporated into the catheter tubing  
20 beneath the stent biomaterial. The stent is maneuvered into the desired location whereupon the deformable metal of the stent is activated such that it apposes the stent against the vessel wall. Laser light is then delivered via an optical fiber based system, also incorporated  
25 into the catheter assembly.

The elastin-based biomaterial can also be used to replace portions of diseased or damaged vascular or nonvascular tissue such as esophagus, paracardium, lung plura, etc. The biomaterial can also be used as a skin

layer replacement, for example, in burn or wound treatments. As such, the biomaterial serves as a permanent dressing that acts as a scaffolding for epithelial cell regrowth. The biomaterial can include antibiotics, coagulants or other (drugs desirable for various treatments that provide high local concentrations with minimal systemic drug levels. The elastin biomaterial can be deployed with a dye on the tissue side and then fused with the appropriate wavelength and laser energy.

In addition to repair of tubular body structures, the biomaterial of the present invention can also be used in organ reconstruction. For example, the biomaterial can be molded or otherwise shaped as a pouch suitable for use in bladder reconstruction. The biomaterial of the invention can also be molded or otherwise shaped so as to be suitable for esophageal replacement. Again, metal or synthetic mesh could also be associated with the implant if extra wall support is needed so as to control passage of food from the pharynx to the stomach. This could be used for stenosis of the esophagus, repair from acid reflux for erosive esophagitis or, more preferably, for refurbishing damaged esophageal segments during or following surgery or chemotherapy for esophageal carcinoma.

For certain applications, it may be desirable to use the biomaterial of the invention in combination with a supporting material having strong mechanical properties. For those applications, the biomaterial can be coated on

the supporting material (see foregoing stent description), for example, using the molding techniques described herein. Suitable supporting materials include polymers, such as woven polyethylene terephthalate (Dacron), teflon, polyolefin copolymer, polyurethane polyvinyl alcohol or other polymer. In addition, a polymer that is a hybrid between a natural polymer, such as fibrin and elastin, and a non-natural polymer such as a polyurethane, polyacrylic acid or polyvinyl alcohol can be used (sets Giusti et al, Trends in Polymer Science 1:261 (1993)). Such a hybrid material has the advantageous mechanical properties of the polymer and the desired biocompatibility of the elastin based material. Examples of other prostheses that can be made from synthetics (or metals coated with the elastin biomaterial or from the biomaterial/synthetic hybrids include cardiac valve rings and esophageal stents.

The elastin-based prostheses of the invention can be prepared so as to include drug; that can be delivered, via the prostheses, to particular body sites. For example, vascular stents can be produced so as to include drugs that prevent coagulation, such as heparin, or antiplatelet drugs such as hirudin, drugs to prevent smooth muscle ingrowth or drugs to stimulate endothelial damaged esophageal segments during or following surgery or chemotherapy for esophageal carcinoma.

For certain applications, it may be desirable to use the biomaterial of the invention in combination with a supporting material having strong mechanical properties.

For those applications, the biomaterial can be coated on the supporting material (see foregoing stent description), for example, using the molding techniques described herein. Suitable supporting materials include polymers, such as woven polyethylene terephthalate (Dacron), teflon, polyolefin copolymer, polyurethane polyvinyl alcohol or other polymer. In addition, a polymer that is a hybrid between a natural polymer, such as fibrin and elastin, and a non-natural polymer such as a polyurethane, polyacrylic acid or polyvinyl alcohol can be used (sets Giusti et al, Trends in Polymer Science 1:261 (1993)). Such a hybrid material has the advantageous mechanical properties of the polymer and the desired biocompatibility of the elastin based material. Examples of other prostheses that can be made from synthetics (or metals coated with the elastin biomaterial or from the biomaterial/synthetic hybrids include cardiac valve rings and esophageal stents.

The elastin-based prostheses of the invention can be prepared so as to include drug that can be delivered, via the prostheses, to particular body sites. For example, vascular stents can be produced so as to include drugs that prevent coagulation, such as heparin, or antiplatelet drugs such as hirudin, drugs to prevent smooth muscle ingrowth or drugs to stimulate endothelial regrowth. Vasodilators can also be included. Prostheses formed from the elastin based biomaterial can also be coated with viable cells damaged esophageal

segments during or following surgery or chemotherapy for esophageal carcinoma.

For certain applications, it may be desirable to use the biomaterial of the invention in combination with a supporting material having strong mechanical properties. For those applications, the biomaterial can be coated on the supporting material (see foregoing stent description), for example, using the molding techniques described herein. Suitable supporting materials include polymers, such as woven polyethylene terephthalate (Dacron), teflon, polyolefin copolymer, polyurethane polyvinyl alcohol or other polymer. In addition, a polymer that is a hybrid between a natural polymer, such as fibrin and elastin, and a non-natural polymer such as a polyurethane, polyacrylic acid or polyvinyl alcohol can be used (sets Giusti et al, Trends in Polymer Science 1:261 (1993)). Such a hybrid material has the advantageous mechanical properties of the polymer and the desired biocompatibility of the elastin based material. Examples of other prostheses that can be made from synthetics (or metals) coated with the elastin biomaterial or from the biomaterial/synthetic hybrids include cardiac valve rings and esophageal stents.

The elastin-based prostheses of the invention can be prepared so as to include drug; that can be delivered, via the prostheses, to particular body sites. For example, vascular stents can be produced so as to include drugs that prevent coagulation, such as heparin, drugs to prevent smooth muscle ingrowth or drugs to

stimulate endothelial regrowth. Vasodilators can also be included. Prostheses formed from the elastin based biomaterial can also be coated with viable cells, preferable, cells from the recipient of the prosthetic device. Endothelial cells, preferably autologous (eg harvested during liposuction), can be seeded onto the elastin bioprosthesis prior to implantation (eg for vascular stent indications). Alternatively, the elastin biomaterial can be used as a skin replacement or repair media where cultured skin cells can be placed on the biomaterial prior to implantation. Skin cells can thus be used to coat elastin biomaterial.

Certain aspects of the invention are described in greater detail in the non-limiting Examples that follow.

#### Example 1 Preparation of Sheets of Elastin--Based Biomaterial from Soluble Peptides

##### Materials used for biomaterial production:

Phosphate buffer: The phosphate buffer used contained 1 mM sodium phosphate, 150 mM sodium chloride, 2 mM calcium chloride, 1 mM magnesium (chloride, pH 7.4.

Soluble elastin peptides: Bovine ligamentum nuchae elastin powder was obtained from Sigma, St. Louis, Missouri. The following procedure was used to obtain the soluble elastin peptides: 2.7 g elastin powder was suspended in 35 ml of a 1M KOL solution in 80% ethanol.



The suspension was stirred at 50°C for 2.5 hr. Next, 10 ml deionized water was added and the solution neutralized with concentrated 12M HCl to pH 7.4. The solution was cooled at 4°C for 12 hrs. The clear  
5 solution was decanted from the salt crystals, and the supernatant centrifuged for 15 mins at 2000 rpm. The solution was then dialyzed against three changes of tap water at two hour intervals and one 15 hr interval using a 10,000 MW cutoff dialysis tubing. The dialysis was  
10 continued with six changes of deionized water at two hour intervals and one for 15 hrs. The resulting dialyZate was lyophilized and stored at -20°C. The yield was 40%.

15 Cryoglobulin preparation: A modification of the method of Pool and Shannon was used to Produce the cryoglobulins (New Engl. J. Med. 273 (1965)). Cryoglobulins are principally fibrinogen (40 mg/ml) and fibronectin (10 mg/ml) (concentrations of fibrinogen  
20 and fibronectin will vary). Briefly, blood was collected from swine in a standard 500 ml blood collection bag containing adenine, citrate and dextrose anticoagulant. The blood was transferred to twelve 50 ml  
plastic centrifuge tubes and centrifuged for 15 mins at  
25 1500 rpm. The plasma was decanted from the erythrocyte layer and frozen at -70°C for 12 hrs. The plasma was then thawed at 4°C. The cryoglobulins were collected by centrifugation of the plasma at 4°C for 15 mins at 1500 rpm. The supernatant was decanted and the cryoglobulins

collected by removing the precipitate with a pasteur  
pipette. Each tube was also rinsed with 3 ml of a  
sodium citrate solution containing 0.9% NaCl, and 0.66%  
sodium citrate. The cryoglobulins were pooled, frozen  
5 at -70°C, lyophilized and stored at -20°C until use.

Thiourea: Reagent grade thiourea. was obtained from  
Sigma, St. Louis, Missouri. A 0.5 mg/ml solution was  
used.

10

Type I collagen: Acid soluble type I collagen was  
obtained from Sigma. It was preferred from rat tail  
tendon by a modification of the method of Bornstein. Two  
mg of collagen was heated in 0.6 ml phosphate buffer to  
15 60°C for 10 minutes until the collagen dissolved. It  
was then cooled to 37°C and used.

Thrombin: Thrombin from bovine plasma was obtained  
from Sigma in lyophilized form. When reconstituted with  
20 1 ml water, the solution contained 106 NIH units per ml.

Aprotinin: Aprotinin from bovin lung was obtained  
from Sigma. It contained 15-30 trypsin inhibitory units  
(TIU) per ml.

25

#### Preparation:

Six molds were made by gluing a 620  $\mu$ m quartz fiber  
to one side of a glass plate ~40 mm x 25 mm and  
attaching a

25

second glass plate to the first using a rubber band.  
Each mold so constructed held about 0.5 ml.

5 The biomaterial was prepared by successively adding  
and mixing the following: 200 mg soluble kappa-elastin  
or kappa-elastin powder in 2ml phosphate buffer (PB)  
(1 mM P041 150 mM NaCl, 2 mM Ca21 1 mM Mg21 PH 7.4) at  
37°C

10 160 mg cryoglobulin in 1 ml P:B (37°C)  
2 mg collagen in 0.6 ml PB (60°C 37°C)  
200 )11 thiourea (0.5 mg/ml)  
200 CL1 aprotinin (5 Units)

15 A 0.6 ml aliquot of the above solution was loaded  
into a test tube and 50  $\mu$ l thrombin solution was added  
(~6 units). The resulting solution was immediately  
loaded into the mold. Certain of the resulting sheets  
were crosslinked with glutaraldehyde for 2 mins.

20 Results:

The sheets prepared as described above were  
slightly yellowish and opaque. The glutaraldehyde-fixed  
sheets were less stretchy and tore more easily than  
25 non-fixed sheets. Glutaraldehyde fixed sheets were  
subjected to election microscopy. These sheets had a  
smooth cohesive surface appearance at 100X and 1000X.

Example 2 Tissue Welding of Sheets of Elastin-Based  
Biomaterial

Pre-welding procedure: A 1 mg/ml ICG solution was  
5 applied to fresh swine aorta that had been carefully  
trimmed of adventitia, washed in a sterile 0.9% NaCl  
solution, and cut into 1cm<sup>2</sup> squares. The 1mg/ml ICG  
solution was applied to the luminal side of the aorta  
for ~3 min and wiped off. (ICG was obtained from Sigma  
10 and contained 90% dye and 10% sodium iodide. Absorption  
coefficient measured at 780 nm with a  $7.25 \times 10^{-6}$  M  
solution was found to be  $175,000 \text{ M}^{-1}\text{cm}^{-1}$ . The adsorption  
maximum shifts to 805nm when ICG is bound to serum  
proteins (Landsman et al, J. Appl. Physiol. 40  
15 (1976)).) A small amount of cryoglobulins, containing  
approximately 40mg/ml fibrinogen and 10mg/ml fibronectin  
doped with ICG, was also applied and the biomaterial  
placed on it. The two materials were placed between  
two glass slides. This was submerged in a 0.9% saline  
20 solution. Welding Procedure: Sheets of biomaterial  
made as described in Example 1 were equilibrated in  
phosphate buffer, pH 7.4, and welded to ICG stained  
porcine aorta using an aluminum gallium arsenide diode  
array laser. The maximum output was at  $808 \pm 1.5\text{nm}$ .  
25 The laser was coupled to a  $1\mu\text{m}$  quartz fiber with  
polyethylene cladding material. The laser energy was  
collimated with a focusing lens and coupled to the  
quartz fiber. The spot size at the distal end of the  
fiber could be varied from 1mm to 4mm by adjusting the

distance between the focusing lens and the proximal end of the fiber. The laser operated continuously, CW, and the output measured at the distal end of the fiber was 1.5W. The quartz fiber was positioned directly above the glass slide, biomaterial, aorta. Before welding, the spot size of the laser was measured. Welding appeared to occur under saline at irradiances of 0.85W but not 1.32W. Twenty seconds was sufficient time to weld and 40 seconds caused a brown color change and charring of the biomaterial.

### Example 3 Preparation of Elastin-Based Biomaterial from Artery Digest

Fresh 4 cm lengths of porcine carotid artery were dissected clean and washed in two changes of 0.9% saline overnight. Vessels were then placed in 0.5M NaOH and sonicated for 120 minutes (a modified method of Crissman, R. 1987) (Crissman, Rogert S. "Comparison of Two Digestive Techniques for Preparation of Vascular Elastic Networks for SEM Observation", Journal of Electron Microscopy Techniques 6:335-348 (1987)). Digested vessels were then washed in distilled water and autoclaved at 225°F for 30 minutes. Digested vessels appear translucent, pearly white in color and collapsed when removed from water indicating the absence of collagen and other structurally supportive proteins.

Welding of the artery digests to porcine aorta was accomplished through the following methods. Fresh porcine aorta was coated with 5 mJ/ml ICG for 5 minutes. Excess ICG solution was blotted off. One x one cm sections of NaOH-sonicated digested carotid artery elastin segments were placed upon the freshly stained aortas. An array of pulsed aluminum gallium arsenide diode lasers (Star Medical Techno.Logies) was used to weld the segments. Five millisecond pulses at 790-810 light was emitted at 2 joules and applied to the tissue with a condenser that created a uniform beam 4x4 mm which was placed on the elastin digest covered by a glass coverslip. Good welds were achieved with up to 10 pulses. A light microscopic photograph of the elastin digest welded to the porcine aorta is shown in Figure 6.

#### Example 4 Preparation of Elastin-Based Biomaterial & Fusion to Porcine Aorta

20

Materials: Bovine nuchal elastin powder (Sigma St. Louis MO) was sifted with a 40  $\mu\text{m}$  screen and swollen with phosphate buffer. Elastin fragments were then reacted with 67 mg of fibrinogen (Sigma):in phosphate buffer, 2m acid soluble Type 1 collagen (Sigma), 2.8 mg thiourea, 2 mM  $\text{Ca}^{2+}$ , 1mM  $\text{Mg}^{2+}$  and 75 units of thrombin and injected into molds and heated to 77°C. One mm thick sheets and tubes of this biomaterial were removed and stored in 33% ethanol for later use.

Indocyanine green dye was dissolved in de-ionized water to provide a 1% solution and applied to the luminal surface of fresh porcine aorta. The dye was in place for 5 minutes then the residual dye was blotted off. The elastin biomaterial was placed on the ICG stained aorta and covered with a glass coverslip. Laser energy was applied with a condenser which collected the output of an array of gallium arsenide diode lasers emitting light at 800nm in 5 msec pulses. Six mm<sup>2</sup> spots were irradiated with 2.89 Joules for 1-10 pulses which provided adequate welds. Samples were then bisected and fixed in formalin for microscopic study. Figure 5 is a light microscopic photograph of such a weld stained with an elastin stain. Excellent welding of the elastin biomaterial to porcine aorta is noted with no detectable thermal or other injury to the biomaterial or aorta.

Example 5 Preparation of Elastin-Based Biomaterial & Fusion to Porcine Aorta

Materials: Bovine ligamentum nuchae elastin, Fibrinogen from porcine plasma, and acid soluble type I collagen from rat tail tendon were obtained from Sigma Chemical Corp. (St. Louis, MS.). Elastin was solubilized in 1M KOL/80% ethanol at 50°C for 2.5 hrs. (Hornbreck). Cryoprecipitates were obtained from porcine plasma according to the method of Pool and Shannon (Pool and Shannon). Fresh porcine aorta was

obtained from Carlton Packaging Co. (Carlton, Ore) and stored at -20°C until thawed for use.

Elastin-fibrin biomaterials was prepared similarly to methods developed by Rabaud (Rabaud). Patches made of  
5 solubilized elastin and cryoprecipitates were prepared by successive addition with thorough mixing of 200mg. soluble elastin dissolved in 2ml buffer, 160 mg. lyophilized cryoprecipitate dissolved in 1 ml buffer, 2 mg type I collagen dissolved in 0.6 ml buffer, and 0.2  
10 ml thiourea solution (0.5 mg/ml H<sub>2</sub>O)). 6 units of thrombin were added to 0.5 ml. aliquots of the mixture, thoroughly mixed in a 1 ml syringe, and injected into 4cm<sup>2</sup> glass molds. The molds were incubated at 37 C for 30 min. and subjected to 25 mrad of ofg-radiation  
15 (cobalt source). The biomaterial was stored at 4°C in 33% etOH. Prior to use the biomaterial was washed several times with saline.

Patches were also made with insoluble elastin and fibrinogen. Lyophilized elastin from Sigma was passed  
20 through a U.S. no 4000 mesh sieve (Tyler) prior to use. Only the 40  $\mu$ m or smaller particles were used. 28-0mg of the filtered elastin was swollen and washed overnight in a n excess of phosphate buffer. the mixture was centrifuged (1000 rpm, 10 min) and the excess buffer  
25 discarded. The swollen elastin was suspended in 2 ml of phosphate buffer. Successively added to this suspension are 67 mg. lyophilized fibrinogen dissolved in 1 ml buffer, 2 mg type I collagen dissolved in 0.6 ml buffer, and 0.2 ml thiourea solution (0.5 mg/ml H<sub>2</sub>O). Finally,



33 units of thrombin were added and the mixture was thoroughly vortexed and quickly poured into 3 cm x 7 cm molds. The molds were incubated at 37°C for 30 min. the biomaterial was stored in 4°C in 33% EtOH. Prior to use  
5 the biomaterial was washed several times with saline solution.

The soluble elastin-cryoprecipitated patch was fused to porcine aorta using an AlGaAr diode array laser emitting 808nm continuous wave optical radiation. Fresh  
10 porcine aorta was washed in 0.9% NaCl and trimmed into 2 cm<sup>2</sup> portions. Indocyanine green (Sigma) in aqueous concentrated of 1 or 5 mg/ml was applied to aorta via a pasteur pipette, left undisturbed for 5 min. and then blotted away. The tissue was then equilibrated in a  
15 0.9% saline solution for 15 minutes to remove any unbound dye. The biomaterial was then applied to the luminal surface of the aorta. the laser beam was directed at the biomaterial surface via a 1 μm fused silica fiber (Polymicro Technologies Phoenix, Az.)  
20 through a glass coverslip as shown in figure 1. the spot size of the laser beam varied between 1-4 mm at distances of. The laser output measured from the fiber tip was 1.5 Watts and exposed durations varied from 5 to 4 seconds.

25 The insoluble elastin-fibrinogen patch was fused to porcine aorta using an AlGaAr diode array laser emitting 790-810nm pulsed optical radiation (Star Medical Technologies). Thawed porcine aorta was prepared and stained with 5mg/ml aqueous ICG solution as previously

described for fresh aorta. After applying the biomaterial to the stained luminal surface of the aorta, laser radiation was directed at the biomaterial via a copper coated condenser placed against a glass coverslip. The laser output was set at 2J and 5 msec pulse durations.

#### Example 6

Bovine ligamentum nuchae elastin, fibrinogen from porcine plasma, and acid soluble type I collagen from rat tale tendon were obtained from Sigma Chemical Corp. (St. Louis, MS).

1 mg. indo cyanine green is dissolved in 1 ml of 24% human serum albumin. 67 mg of fibrinogen was dissolved in 1 ml phosphate buffer (@37°C). Just prior to mixing 16.6 units of thrombin are added to the indocyanine green solution. The mixtures were cooled to 4°C. The two mixtures are rapidly mixed and injected, or poured, into a 3X7 cm mold and incubated for 30 min. at 37°C.

Lyophilized elastin from Sigma was passed through a U.S. no 400 mesh sieve (Tyler) prior to use. Only the 40  $\mu$ m or smaller particles were used. 210 mg of the filtered elastin was swollen and washed overnight in an excess of phosphate buffer. The mixture was centrifuged (1000rpm, 10 min.) and the excess buffer discarded. The swollen elastin was suspended in 1.5 ml of phosphate

buffer. Successively added to this suspension were 67  
mg lyophilized fibrinogen dissolved in 0.75 ml buffer, 2  
mg type I collagen dissolved in 0.45 ml buffer, and 0.15  
ml thiourea solution (0.5mg/ml H<sub>2</sub>O). Finally, 26 units  
5 of thrombin were added and the mixture was thoroughly  
vortexed and quickly poured onto the fibrin matrix doped  
with indocyanine green in the 3 cm x 7 cm molds. The  
molds were again incubated at 37°C for 30 minutes. When  
removed from the mold, the two layers are inseparable  
10 and the preparation yields a single patch.

All documents cited above are hereby incorporated in  
their entirety by reference.

One skilled in the art will appreciate from a  
reading of this disclosure that various changes in form  
15 and detail can be made without departing from the true  
scope of the invention.

## WHAT IS CLAIMED IS:

1. A tissue-fusible elastin or elastin-based biomaterial comprising:

5 a layer of elastin or elastin-based biomaterial and a tissue substrate each having first and second outer surfaces; and

an energy absorbing material applied to at least one of said outer surfaces, said energy absorbing material penetrating into the biomaterial;

10 the energy absorbing material being energy absorptive within a predetermined range of light wavelengths;

the energy absorbing material being irradiated with light energy in said predetermined wavelength range with an intensity sufficient to fuse together one of said first and second outer surfaces of the elastin or elastin-based biomaterial and the tissue substrate.

2. The biomaterial of claim 1, wherein the first and second outer surfaces of said elastin or elastin-based biomaterial are major surfaces.

3. The biomaterial of claim 1, wherein said energy absorbing material is indirectly irradiated by directing the light energy first through the elastin or elastin-based biomaterial or tissue substrate and then to the energy absorbing material.

4. The biomaterial of claim 1, wherein said energy absorbing material comprises a biocompatible chromophore.

5. The biomaterial of claim 1, wherein said energy absorbing material comprises an energy absorbing dye.

6. The biomaterial of claim 1, wherein said energy absorbing material is substantially dissipated when said elastin or elastin-based biomaterial and said tissue substrate are fused together.

7. The biomaterial of claim 1, wherein said energy absorbing material comprises a material for staining the first or second surface of said elastin or elastin-based biomaterial.

8. The biomaterial of claim 1, wherein said energy absorbing material is applied to one of said outer surfaces of said biomaterial by doping a separate elastin layer with an energy absorbing material and then fusing the doped separate elastin layer to the elastin or elastin-based elastin.

9. The biomaterial of claim 1, wherein the energy absorbing layer is substantially uniformly applied to at least one of said outer surfaces.

10. The biomaterial of claim 1, wherein the energy absorbing material substantially covers the entire outer surface of the elastin or elastin-based biomaterial

11. The biomaterial of claim 1, wherein the temperature during irradiation with light energy for period of time which will cause fusing together of one of said first and second outer surfaces of the elastin or elastin-based biomaterial and said tissue substrate is from about 40 to 140 degrees C.

12. The biomaterial of claim 1, wherein the temperature during irradiation with light energy for period of time which will cause fusing together of one of said first and second outer surfaces of the elastin or elastin-based biomaterial and said tissue substrate is from about 50 to 100 degrees C.

13. The biomaterial of claim 1, wherein the average thickness of the energy absorbing material is from about 0.5 to 300 microns.

14. The biomaterial of claim 1, wherein the magnitude of the wave length, energy level, absorption, and light intensity during irradiation with light energy of the energy absorbing material, and the concentration of the energy absorbing material, are arranged so that one of said first and second outer surfaces of the elastin or elastin-based biomaterial and said tissue substrate are fused together at a temperature of from about 40 to 140 degrees C.

15. A process for producing a tissue-fusible elastin or elastin-based biomaterial comprising:

providing a layer of elastin or elastin-based biomaterial and a tissue substrate having first and second outer surfaces; and

applying an energy absorbing material to said first or second outer surface, said energy absorbing material penetrating into the biomaterial;

the energy absorbing material being energy absorptive within a predetermined range of light wavelengths;

the energy absorbing material being irradiated with light energy in said predetermined wavelength range with an intensity sufficient to fuse together one of said first and second outer surfaces of the elastin or elastin-based biomaterial and the tissue substrate.

5 16. The process of claim 15, which further includes the step of providing first and second outer surfaces of said elastin or elastin-based biomaterial which are major surfaces.

10 17. The process of claim 15, which further includes the step of indirectly irradiating said energy absorbing material directing the light energy first through the elastin or elastin-based biomaterial or tissue substrate and then to the energy absorbing material.

15 18. The process of claim 15, wherein said energy absorbing material comprises a biocompatible chromophore.

19. The process of claim 15, wherein said energy absorbing material comprises an energy absorbing dye.

20 20. The process of claim 15, which further includes the step of substantially dissipating said energy absorbing material when said elastin or elastin-based biomaterial and said tissue substrate are fused together.

25 21. The process of claim 15, which further includes the step of staining the first or second surface of said elastin or elastin-based biomaterial with said energy absorbing material.

22. The process of claim 15, which further includes the step of applying said energy absorbing material to one of said outer surfaces of said biomaterial by doping a separate elastin layer with an energy absorbing material and then fusing the doped separate elastin layer to the elastin or elastin-based elastin.

23. The process of claim 15, wherein the energy absorbing layer is substantially uniformly applied to at least one of said outer surfaces.

24. The process of claim 15, which further includes the step of covering substantially the entire outer surface of the elastin or elastin-based biomaterial with the energy absorbing material.

25. The process of claim 15, which further includes the step of irradiating the energy absorbing material with light energy at a temperature of from about 40 to 140 degrees C. for period of time which will cause fusing together of one of said first and second outer surfaces of the elastin or elastin-based biomaterial and said tissue substrate.

26. The process of claim 15, which further includes the step of irradiating the energy absorbing material with light energy at a temperature of from about 50 to 100 degrees C for period of time which will cause fusing together of one of said first and second outer surfaces of the elastin or elastin-based biomaterial and said tissue substrate.



27. The process of claim 15, wherein the average thickness of the energy absorbing material is from about 0.5 to 300 microns.

5 28. The process of claim 15, which further includes the step of arranging the magnitude of the wave length, energy level, absorption, and light intensity during irradiation with light energy of the energy absorbing material, and the concentration of the energy absorbing material, so temperature of said first and second outer  
10 surfaces of the elastin or elastin-based biomaterial and the tissue substrate are maintained at from about 40 to 140 degrees C thereby fusing together the elastin or elastin-based biomaterial and the tissue substrate.

15 29. A fused live tissue-elastin-based biomaterial composite, which comprises:

a layer of elastin or elastin-based biomaterial and a tissue substrate each having first and second outer surfaces;

20 an energy absorbing material, which is energy absorptive within a predetermined range of light wavelengths, said energy absorbing material being applied to at least one of said first and second outer surfaces of said elastin or elastin-based biomaterial or said tissue substrate in an amount sufficient to  
25 directly fuse said biomaterial layer and said tissue substrate to each other; and

at least one of the first and second outer surfaces of said tissue substrate being fused directly to at least one of the first and second outer surfaces of the

elastin or elastin-based biomaterial by irradiation of the energy absorbing material with light energy emitted in the predetermined wavelength range with an intensity sufficient which directly fuses together the elastin or elastin-based biomaterial and the tissue substrate.

5

30. A process for producing a live tissue-fusible elastin-based biomaterial, comprising:

providing a layer of elastin or elastin-based biomaterial and a tissue substrate having first and second outer surfaces; and

10

applying a energy absorbing material, which is energy absorptive within a predetermined range of light wavelengths, to one of the first or second outer surfaces of said elastin or elastin-based biomaterial or tissue substrate;

15

positioning the first or second outer surface of said elastin or elastin-based biomaterial and said tissue substrate into contact with each other, so that said energy absorbing material is disposed between said the elastin or elastin-based biomaterial and the tissue substrate; and

20

irradiating the energy absorbing material with light energy in said predetermined wavelength range with an intensity sufficient to fuse together said first or second outer surfaces of the elastin or elastin-based biomaterial and the tissue substrate.

25

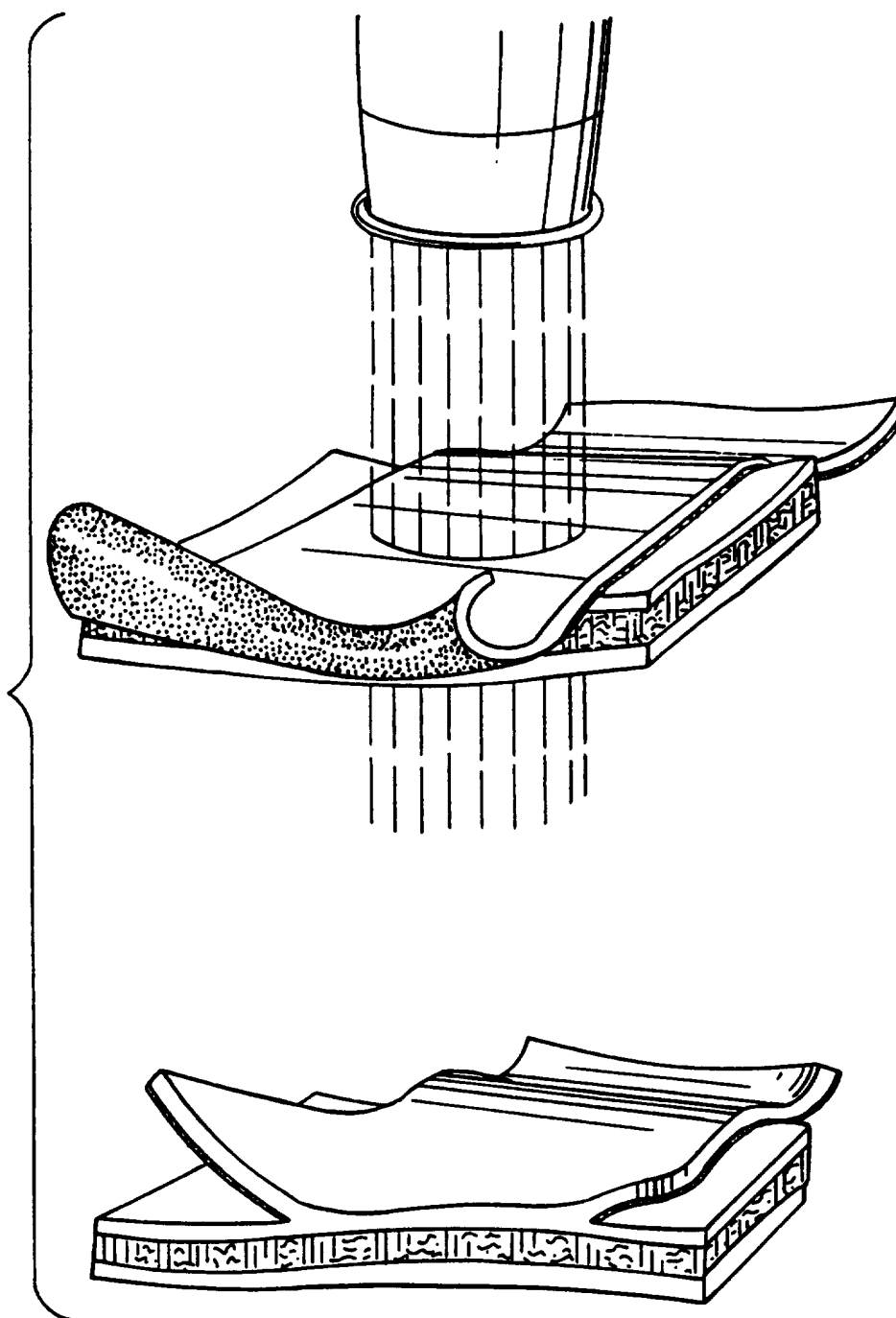

**FIG. 1**

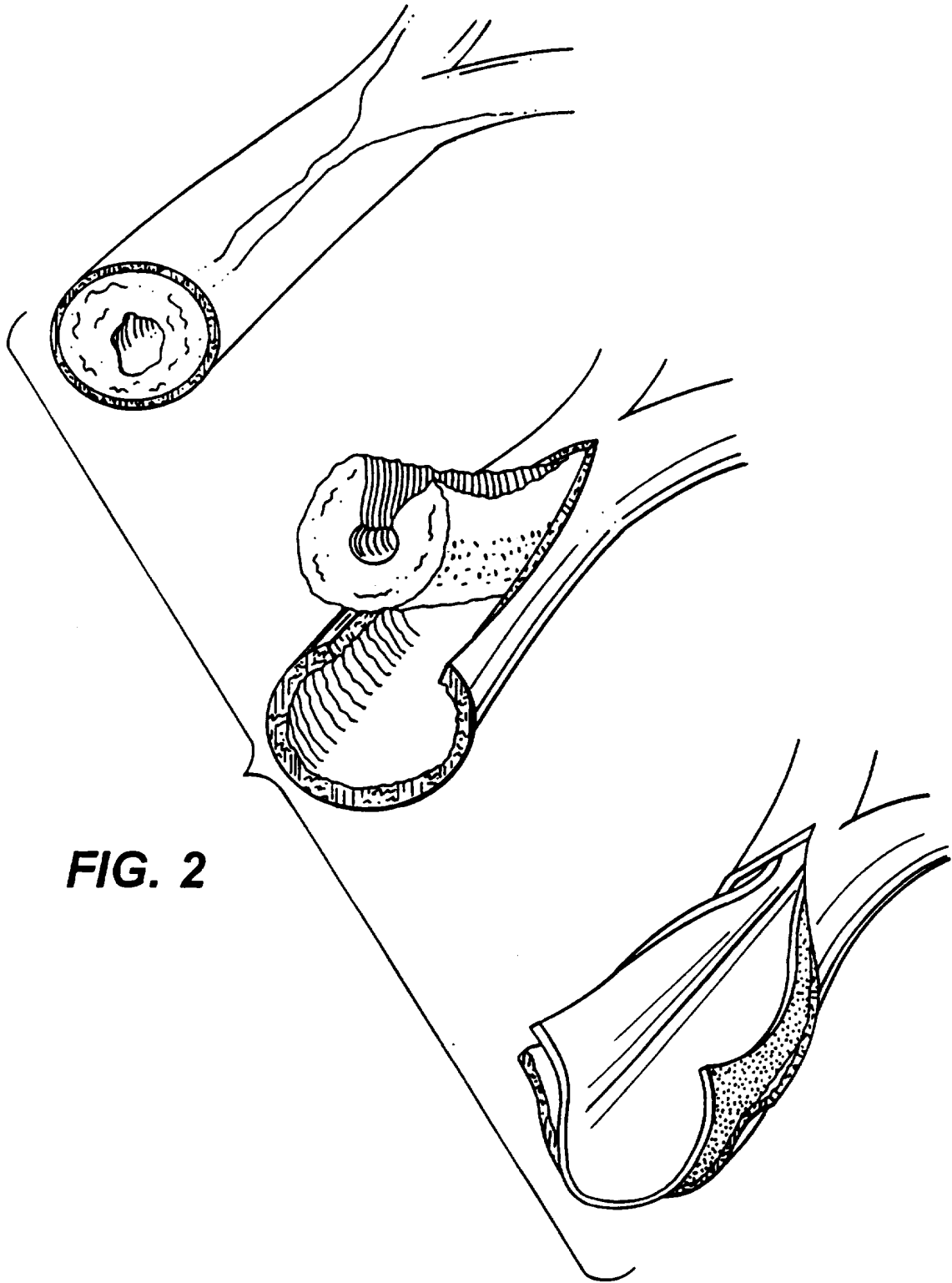

**FIG. 2**

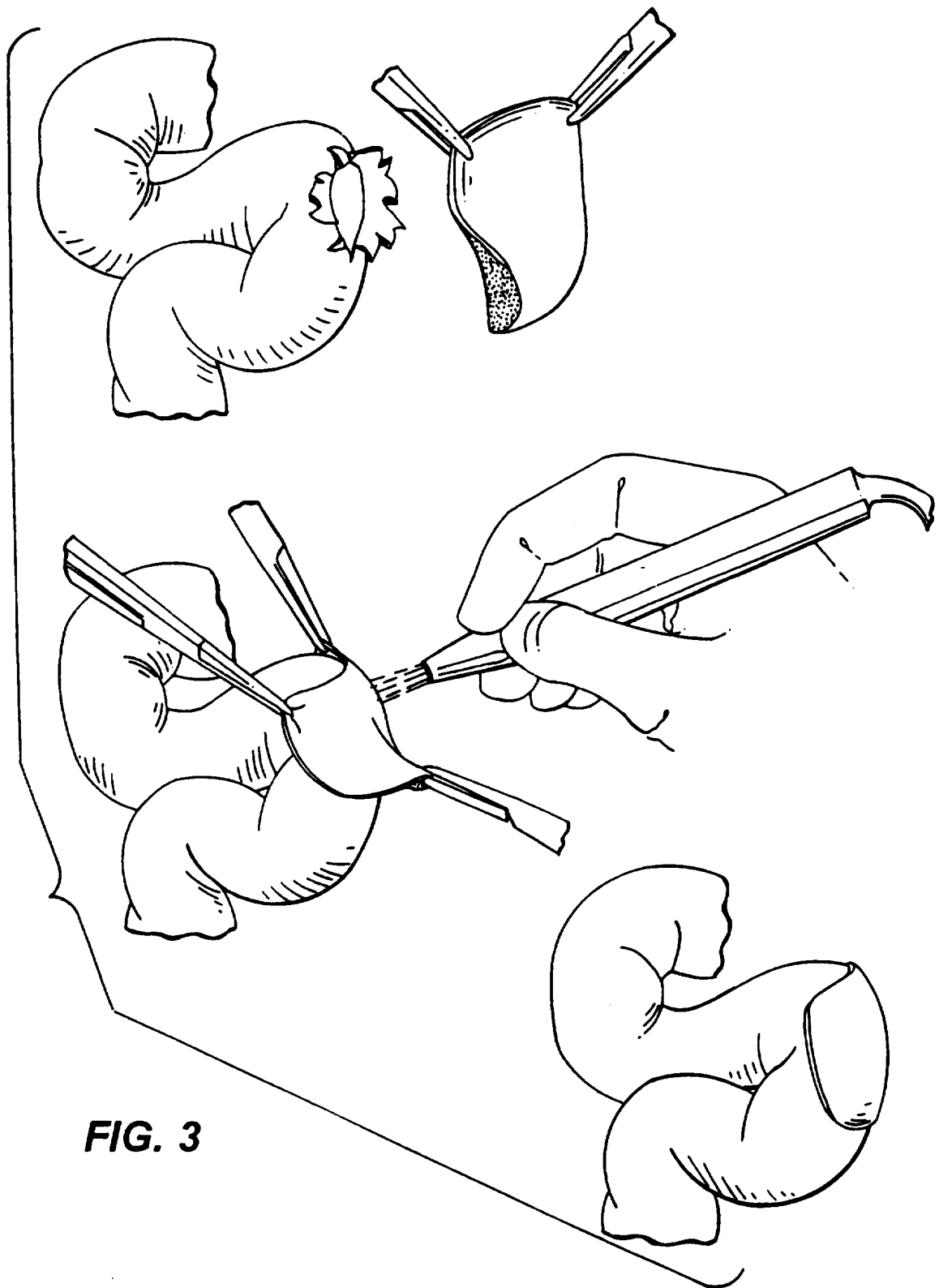

**FIG. 3**

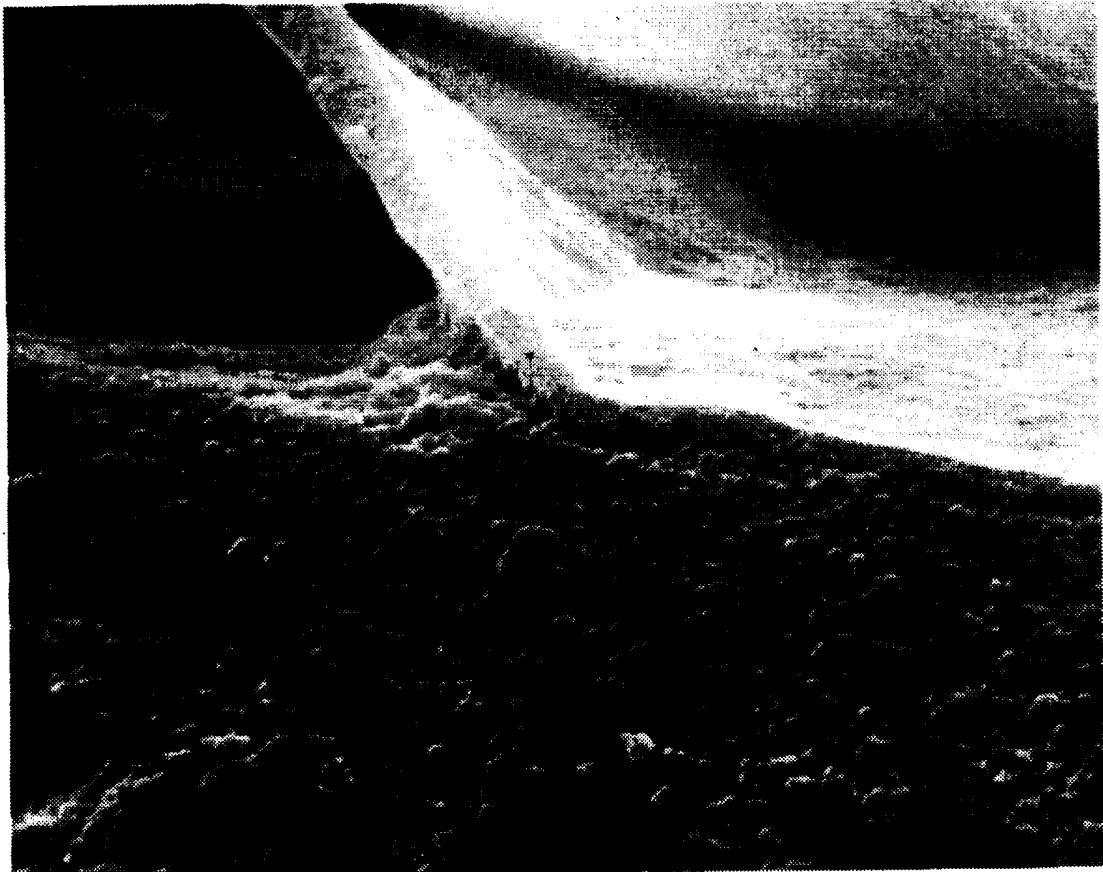

**FIG. 4**

**FIG. 5**



FIG. 6





INTERNATIONAL SEARCH REPORT

International application No.  
PCT/US95/04236

A. CLASSIFICATION OF SUBJECT MATTER

IPC(6) :A61F 2/02  
US CL :623/11

According to International Patent Classification (IPC) or to both national classification and IPC

B. FIELDS SEARCHED

Minimum documentation searched (classification system followed by classification symbols)

U.S. : 128/DIG.8; 606/2, 3, 8, 10; 607/50; 623/11, 16, 66

Documentation searched other than minimum documentation to the extent that such documents are included in the fields searched  
NONE

Electronic data base consulted during the international search (name of data base and, where practicable, search terms used)  
Please See Extra Sheet.

C. DOCUMENTS CONSIDERED TO BE RELEVANT

Category*	Citation of document, with indication, where appropriate, of the relevant passages	Relevant to claim No.
A	US, A, 5,156,613 (SAWYER) 20 October 1992. See column 7 line 62 to column 8 line 47.	1-30
A	US, A, 5,254,113 (WILK) 19 October 1993. See Abstract.	1-30

Further documents are listed in the continuation of Box C.  See patent family annex.

* Special categories of cited documents:	"T" later document published after the international filing date or priority date and not in conflict with the application but cited to understand the principle or theory underlying the invention
"A" document defining the general state of the art which is not considered to be part of particular relevance	"X" document of particular relevance; the claimed invention cannot be considered novel or cannot be considered to involve an inventive step when the document is taken alone
"E" earlier document published on or after the international filing date	"Y" document of particular relevance; the claimed invention cannot be considered to involve an inventive step when the document is combined with one or more other such documents, such combination being obvious to a person skilled in the art
"L" document which may throw doubts on priority claim(s) or which is cited to establish the publication date of another citation or other special reason (as specified)	"A" document member of the same patent family
"O" document referring to an oral disclosure, use, exhibition or other means	
"P" document published prior to the international filing date but later than the priority date claimed	

Date of the actual completion of the international search

04 JUNE 1995

Date of mailing of the international search report

16 JUN 1995

Name and mailing address of the ISA/US  
Commissioner of Patents and Trademarks  
Box PCT  
Washington, D.C. 20231

Facsimile No. (703) 305-3230

Authorized officer

ROBERT CLARKE

Telephone No. (703) 308-2908

*Stacia Simcik for*

# INTERNATIONAL SEARCH REPORT

International application No.  
PCT/US95/04236

## B. FIELDS SEARCHED

Electronic data bases consulted (Name of data base and where practicable terms used):

APS

Search Terms: elastin, collagen, irradiate, radiat eenergy, chromopore, dye, fuse, fusion