



- (51) International Patent Classification: *H04M 1/02* (2006.01)
- (21) International Application Number: PCT/US2012/024830
- (22) International Filing Date: 13 February 2012 (13.02.2012)
- (25) Filing Language: English
- (26) Publication Language: English
- (30) Priority Data: 13/043,915 9 March 2011 (09.03.2011) US
- (71) Applicant (for all designated States except US): **UNIVERSAL ELECTRONICS INC.** [US/US]; 6101 Gateway Drive, Cypress, California 90630-4841 (US).
- (72) Inventors; and
- (75) Inventors/Applicants (for US only): **HILBRINK, Marcel** [NL/SG]; 58 Swiss view # 01-04 (SG). **HAYES, Patrick, H.** [US/US]; 22981 Arija, Mission Viejo, California 92691 (US).
- (74) Agents: **JAROSIK, Gary, R.** et al.; Greenberg Traurig, LLP, Suite 3100, 77 W. Wacker Drive, Chicago, Illinois 60601-1732 (US).
- (81) Designated States (unless otherwise indicated, for every kind of national protection available): AE, AG, AL, AM, AO, AT, AU, AZ, BA, BB, BG, BH, BR, BW, BY, BZ, CA, CH, CL, CN, CO, CR, CU, CZ, DE, DK, DM, DO, DZ, EC, EE, EG, ES, FI, GB, GD, GE, GH, GM, GT, HN, HR, HU, ID, IL, IN, IS, JP, KE, KG, KM, KN, KP, KR, KZ, LA, LC, LK, LR, LS, LT, LU, LY, MA, MD, ME, MG, MK, MN, MW, MX, MY, MZ, NA, NG, NI, NO, NZ, OM, PE, PG, PH, PL, PT, QA, RO, RS, RU, RW, SC, SD, SE, SG, SK, SL, SM, ST, SV, SY, TH, TJ, TM, TN, TR, TT, TZ, UA, UG, US, UZ, VC, VN, ZA, ZM, ZW.
- (84) Designated States (unless otherwise indicated, for every kind of regional protection available): ARIPO (BW, GH, GM, KE, LR, LS, MW, MZ, NA, RW, SD, SL, SZ, TZ, UG, ZM, ZW), Eurasian (AM, AZ, BY, KG, KZ, MD, RU, TJ, TM), European (AL, AT, BE, BG, CH, CY, CZ, DE, DK, EE, ES, FI, FR, GB, GR, HR, HU, IE, IS, IT, LT, LU, LV, MC, MK, MT, NL, NO, PL, PT, RO, RS, SE, SI, SK, SM, TR), OAPI (BF, BJ, CF, CG, CI, CM, GA, GN, GQ, GW, ML, MR, NE, SN, TD, TG).

[Continued on next page]

(54) Title: SYSTEM AND METHOD FOR PROVISION OF INFRARED SIGNALLING IN SMART PHONE DEVICES

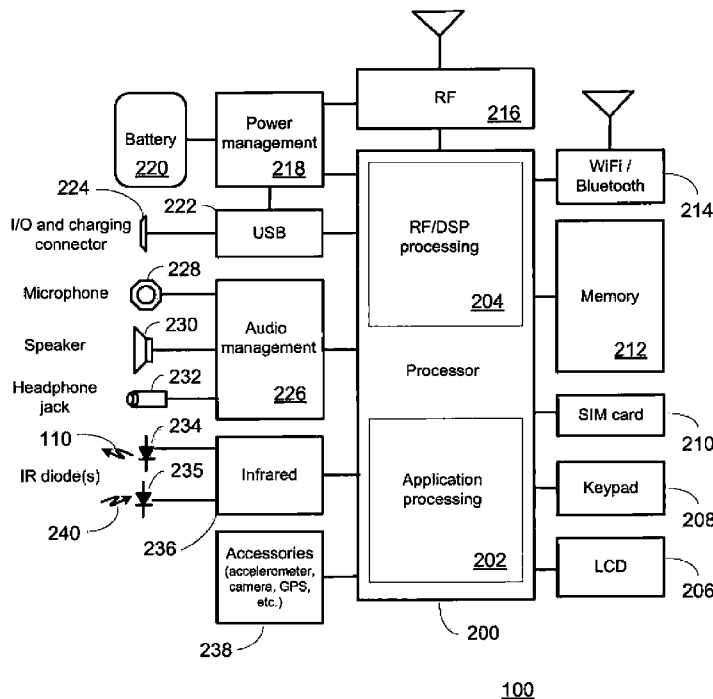

Figure 2

(57) Abstract: A smart phone device is fitted with a dual mode communications interface device having a housing wherein the housing provides access via an exterior of the smart phone device to both an infrared communications pathway and an electrical communications pathway each of which are coupled to one or more processing devices carried within the smart phone device. To this end, the communications interface device may be in the form of an audio jack having a plug receiving opening wherein the plug receiving opening is in communication with the electrical communications pathway and wherein at least a portion of the housing surrounding the plug receiving opening forms a light pipe for the infrared communications pathway.

WO 2012/121833 A1

**Published:**

— *with international search report (Art. 21(3))*

## SYSTEM AND METHOD FOR PROVISION OF INFRARED SIGNALLING IN SMART PHONE DEVICES

5

### BACKGROUND

Personal communication, productivity, and entertainment devices such as cellular phones, portable email devices, tablet computers, e-books, hand-held games, portable media players, etc. (all referred to hereafter as “smart phones”) are known to include features such as graphical user interfaces on color touch screens, wireless Internet capability, support for ancillary applications (sometimes referred to as “apps”) such as, for example, calendars, email, maps and navigation, etc. Such ancillary applications may be pre-installed in a smart phone or may be made available for download by a user. Certain such apps may comprise an ability to issue commands to entertainment and other appliances, for example in conjunction with a GUI offering the features and functionality of a universal remote control as known in the art, in conjunction with a TV guide display to enable channel selection, etc. Since many appliance command protocols comprise transmission of a pulse train modulated onto an infrared (“IR”) carrier signal, it is desirable that smart phones be equipped with an IR transmitting means to support such apps.

20

### SUMMARY OF THE INVENTION

This invention relates generally to a system and method for implementation of certain hardware elements required to support IR signal generation in smart phones, and more particularly to cost-effective and space conserving methods for provisioning of an IR transmitter diode. To this end, in an illustrative embodiment presented herein, a connector opening in the outer case of a smart phone may be fitted with a connector body which serves not only the original purpose for which the opening was intended, but also doubles as a light pipe to disseminate IR signals generated by an IR emitter diode located internal to the smart phone device.

A better understanding of the objects, advantages, features, properties and relationships of the invention will be obtained from the following detailed description and accompanying drawings which set forth illustrative embodiments and which are indicative of the various ways in which the principles of the invention may be employed.

35

## BRIEF DESCRIPTION OF THE DRAWINGS

For a better understanding of the various aspects of the invention, reference may be had to preferred embodiments shown in the attached drawings in which:

Figure 1 illustrates an exemplary system in which an exemplary smart phone may  
5 be used as a controlling device;

Figure 2 illustrates in block diagram form the major components of the exemplary smart phone device of Figure 1;

Figures 3a and 3b illustrate exemplary smart phone devices according to the prior art;

10 Figure 3c illustrates an exemplary smart phone device according to the instant invention;

Figures 4a illustrates an exemplary headphone connector mechanism according to the prior art;

15 Figures 4b and 4c illustrate exemplary headphone connector mechanisms according to the instant invention;

Figure 5a illustrates the internal configuration of the headphone connector mechanism of Figure 4b;

Figure 5b illustrates the internal configuration of the headphone connector mechanism of Figure 4c;

20 Figure 5c illustrates the light guide functionality of the connectors of Figure 5a or 5b;

Figure 6 illustrates an alternative utilization of the headphone connector mechanism of Figures 4c and 5b; and

25 Figure 7 illustrates an alternative smart phone component in which the teachings of the instant invention may be embodied.

## DETAILED DESCRIPTION

Turning now to Figure 1, there is illustrated an exemplary system in which a smart phone device 100 is equipped to control various controllable appliances, such as a  
30 television 102, a set top box ("STB") 104, an AV receiver 106, and a DVD player 108. As is known in the art, the smart phone device may be capable of transmitting commands to the appliances, using appropriate infrared ("IR") signals 110 recognizable by the target appliances, to cause the appliances to perform one or more operational functions. While illustrated in the context of a television 102, STB 104, AV receiver 106, and DVD player

108 it is to be understood that controllable appliances may include, but need not be limited to, televisions, VCRs, DVRs, DVD players, cable or satellite converter set-top boxes (“STBs”), amplifiers, CD players, game consoles, home lighting, drapery, fans, HVAC systems, thermostats, personal computers, etc.

5           With reference to Figure 2, as is known in the art, a smart phone device 100 may include as needed for a particular application, processing means 200 which may comprise both an application processing section 202 and an RF/DSP processing section 204; an LCD display 206; a keypad 208 which may comprise physical keys, touch keys  
10           overlying LCD 206, or a combination thereof; a subscriber identification module (SIM) card 210; memory means 212 which may comprise ROM, RAM, Flash, or any combination thereof; WiFi and/or Bluetooth wireless interface(s) 214; a wireless telephony interface 216; power management circuitry 218 with associated battery 220; a USB interface 222 and connector 224; an audio management system 226 with associated microphone 228, speaker 230, and headphone jack 232; optional IR communication  
15           means comprising a transmitter and/or receiver 236 with associated IR output diode(s) 234 and input diode(s) 235; and various optional accessory features 238 such as a digital camera, GPS, accelerometer, etc.

          In order to increase the utility of such devices, it is known to offer an app which allows use of the smart phone to transmit commands suitable for operation of  
20           entertainment and other appliances. In many instances, such an app may draw on a library of codes and data suitable for commanding the functional operations of various types of appliances of multiple manufactures and/or models, i.e., a library of remote control code sets for a so-called “universal” controller, as well known in the art. In other instances, a particular app may be suitable for the control of only a specific target device  
25           or group of devices, such as those offered by one manufacturer, those intended to perform a particular function, etc., i.e., a library of one or more remote control code sets for a so-called “dedicated” controller. Various methods for physical implementation of such command transmissions are known: for example, an IR communication means 236 may be incorporated into a smart phone 100. IR communication means 236 may take the form  
30           of a self-contained microcontroller IC which includes both programming and a code library suitable for generating appropriately encoded pulse streams in response to functional commands received from application processing means 202. Alternatively, IR communication means 236 may take the form of a simple driver circuit responsive to a pulse stream output generated directly by programming within application processing

means 202 utilizing a command code library stored in smart phone memory 212. Other permutations are also possible, for example functionality may be divided, with transmission formatting and encoding being performed by a microcontroller comprising IR transmitter 236 in response to command data input retrieved by application processing means 202 from memory 212.

Regardless of the exact method by which it is generated, the final modulated IR signal 110 to be transmitted to a target controlled appliance may be radiated by an IR emitting diode 234. Accordingly, provision must be made for radiation from IR emitter diode 234 to escape the outer case of smart phone 100. Additionally, in those embodiments in which bidirectional IR communication is desired, provision must also be made for incoming IR signals 240 to reach an IR detector 235. Turning now to Figure 3, it is known in the art to provide an IR-transparent window 302, for example of tinted polycarbonate or acrylic plastic, on the front edge of a smart phone 100a, with an IR emitter diode (or diodes) 234 positioned on an internal circuit board immediately behind window 302. However, provision of such a window may be problematic in some implementations, requiring tooling changes to add this feature to an existing case design, as well as allocation of valuable case-edge real estate. Accordingly, it is also known in the art to provide an add-on adapter 304 containing an IR emitter diode 234 (and in some embodiments all or part of IR transmitter 236 as well), which adapter may be attached to a smart phone 100b for example to USB port 224 as illustrated, to headphone jack 232, or to any other suitable externally-accessible connector. Such solutions, while compatible with existing tooling, incur the disadvantages of additional cost and componentry together with the user inconvenience of having to purchase and attach an accessory device while also sacrificing the original functionality for which the connector was intended.

To overcome these disadvantages, the instant invention proposes adapting an existing connector opening in the outer case of smart phone 100c for dual purpose use as shown in Figure 3C. In an exemplary embodiment presented hereafter, the plastic housing of a headphone jack may be adapted to serve as a light pipe to guide and disseminate the radiation 110 from an internally-located IR emitter diode 234.

Turning now to Figure 3C as well as Figures 4a through 4c, Figure 4a illustrates a headphone jack component 232 such as may be found in prior art smart phones 100a or 100b. Headphone jack 232 comprises a receptacle 402 which may protrude through an opening in the outer case of smart phone 100a or 100b and forms part of a housing 404 which may be mounted to a printed circuit board via connector tabs 406. As illustrated

by the circuit representation 410 of this component, tabs 406 are in electrical connection with a set of internal contacts designed to mate with a matching headphone connector.

Figure 4b illustrates a headphone jack component 232a constructed in accordance with the instant invention. Housing 404a may be of a material which is suitable to act as a light pipe in at least the infrared portion of the spectrum and may be adapted to  
5 accommodate an IR emitter diode 234 such that IR emissions are guided through the housing material and caused to exit via the outer face of receptacle 402a, for example in the manner illustrated in Figure 5c, i.e., the housing 404a includes surfaces that are arranged to guide, reflect, and otherwise direct the infrared emission from the IR source  
10 to the IR outlet 402a. As indicated by the circuit representation 412 of this component and by the illustrative internal componentry view presented in Figure 5a, for ease of assembly headphone jack component 232a may incorporate a built-in IR emitter diode 234 into its structure, with additional pins 408 available to connect IR emitter diode 234 to infrared transmitter means 236.

15 In an alternative embodiment illustrated in Figures 4c and 5b, a housing 404b of headphone jack component 232a may incorporate a notch 414 in the base of housing 404b, wherein beneath the notch and directly adjacent to the housing 404b an IR emitter diode component 234 may be positioned, for example mounted to the printed circuit board prior to placement of headphone jack component 232a. In this regard, the IR  
20 emitter diode is placed into light communication with the housing 404b. The circuit representation of such an arrangement is illustrated at 416. As illustrated in Figure 6, when appropriate for a particular embodiment the light pipe of Figures 4c and 5b may be readily adapted to support bidirectional IR communication by the additional placement of an IR receiver component 235 beneath notch 414 and directly adjacent to housing 404b.  
25 Bidirectional IR communication may also be facilitated by placement of an IR receiver component 235 within the housing in a manner similar to which the IR transmitter 234 is placed within the housing as illustrated in Fig. 5a.

Turning to Figure 7, in yet further illustrative embodiment the housing 702 of an exemplary pushbutton switch component 700 may be adapted to guide IR emissions  
30 through the housing material and to exit via the outer flange 704 of pushbutton 706. While illustrative housing 702 comprises a notch 414 beneath which one or more IR emitters or receivers may be positioned as described above in conjunction with the embodiment of Figures 5b, it will be appreciated that other configurations are also possible, for example provision of an internal IR emitter as in the embodiment of Figure

5a, fabrication of all or part of the button 706 itself from a material suitable to act as light pipe, etc.

\* \* \* \* \*

While various concepts have been described in detail, it will be appreciated by those skilled in the art that various modifications and alternatives to those concepts could be developed in light of the overall teachings of the disclosure. For example, in certain embodiments the external surface of a headphone jack, pushbutton switch, or other component housing according to this invention may be furnished with a reflective coating to assist or enhance the light pipe effect. Additionally, it will be appreciated that various alternate shapes and configurations of component housing and various alternate positions for IR emitter diode placement may be used equally effectively. Also, while an exemplary embodiment based upon adaptation of a headphone jack connector or a pushbutton switch to guide emissions from an IR transmitter diode are presented herein by way of illustration, it will be appreciated that the teachings of the instant invention may be applied with equal success to any other connector or component which protrudes through the outer casing of a smart phone and/or may be further adapted to provide for the transfer of light signals in other parts of the spectrum, for example human-visible emissions from a conventional LED for the purposes of user guidance or feedback.

Further, while described in the context of functional modules and illustrated using block diagram format, it is to be understood that, unless otherwise stated to the contrary, one or more of the described functions and/or features may be integrated in a single physical device and/or a software module, or one or more functions and/or features may be implemented in separate physical devices or software modules. It will also be appreciated that a detailed discussion of the actual implementation of each module is not necessary for an enabling understanding of the invention. Rather, the actual implementation of such modules would be well within the routine skill of an engineer, given the disclosure herein of the attributes, functionality, and inter-relationship of the various functional modules in the system. Therefore, a person skilled in the art, applying ordinary skill, will be able to practice the invention set forth in the claims without undue experimentation. It will be additionally appreciated that the particular concepts disclosed are meant to be illustrative only and not limiting as to the scope of the invention which is to be given the full breadth of the appended claims and any equivalents thereof.

All patents cited within this document are hereby incorporated by reference in their entirety.

## CLAIMS

What is claimed is:

1. A portable electronic device, comprising:
  - one or more processing devices carried within the portable electronic device; and
  - 5 a dual mode communications interface device carried within the portable electronic device whereby the dual mode communications interface device is accessible at an exterior of the portable electronic device, the dual mode communications interface device comprising a housing which comprises both a light pipe for providing at least a portion of an infrared communications pathway which is coupled to the one or more
  - 10 processing devices carried within the portable electronic device and at least a portion of an electrical communications pathway which is coupled to the one or more processing devices carried within the portable electronic device.
2. The portable electronic device as recited in claim 1, wherein the portable electronic
- 15 device comprises a smart phone.
3. The portable electronic device as recited in claim 1, wherein the housing comprises an audio jack having a plug receiving opening wherein the plug receiving opening is in communication with the electrical communications pathway.
- 20
4. The portable electronic device as recited in claim 1, wherein the housing comprises one or more surfaces that form the light pipe.
5. The portable electronic device as recited in claim 4, wherein the housing carries an
- 25 infrared emitter coupled to the one or more processing devices.
6. The portable electronic device as recited in claim 4, wherein the housing carries an infrared receiver coupled to the one or more processing devices.
- 30 7. The portable electronic device as recited in claim 4, wherein the portable electronic device comprises an infrared emitter coupled to the one or more processing devices and wherein the infrared emitter is positioned adjacent to the housing.

8. The portable electronic device as recited in claim 4, wherein the portable electronic device comprises an infrared receiver coupled to the one or more processing devices and wherein the infrared receiver is positioned adjacent to the housing.
- 5 9. The portable electronic device as recited in claim 3, wherein the light pipe terminates at an end surface of the housing surrounding at least a portion of the plug receiving opening.
- 10 10. The portable electronic device as recited in claim 1, wherein the electrical communications pathway carried by the housing includes a user activatable input element which is accessible via the exterior of the portable electronic device.
11. The portable electronic device as recited in claim 10, wherein the user activatable input element comprises an electro-mechanical switch.
- 15 12. A dual mode communications interface device for use within a portable electronic device, comprising:  
a housing which comprises both a first terminus that provides access via an exterior of the portable electronic device to an infrared communications pathway coupled to one or more processing devices carried within the portable electronic device and a  
20 second terminus that provides access via the exterior of the portable electronic device to an electrical communications pathway coupled to the one or more processing devices carried within the portable electronic device.
- 25 13. The dual mode communications interface device as recited in claim 12, wherein the housing comprises an audio jack having a plug receiving opening which is in communication with the second terminus.
- 30 14. The dual mode communications interface device as recited in claim 12, wherein the housing comprises one or more surfaces that form a light pipe and wherein the infrared communications pathway includes the light pipe.
15. The dual mode communications interface device as recited in claim 14, wherein the housing carries an infrared emitter couplable to the one or more processing devices.

16. The dual mode communications interface device as recited in claim 14, wherein the housing carries an infrared receiver couplable to the one or more processing devices.

17. The dual mode communications interface device as recited in claim 14, wherein the  
5 housing has a surface adapted to be positioned adjacent to an infrared emitter coupled to the one or more processing devices.

18. The dual mode communications interface device as recited in claim 14, wherein the  
10 housing has a surface adapted to be positioned adjacent to an infrared receiver coupled to the one or more processing devices.

19. The dual mode communications interface device as recited in claim 13, wherein the  
15 first terminus is located at an end surface of the housing surrounding at least a portion of the plug receiving opening.

20. The dual mode communications interface device as recited in claim 12, wherein the  
20 electrical communications pathway carried by the housing includes a user activatable input element which is adapted to be accessible via the exterior of the portable electronic device.

21. The dual mode communications interface device as recited in claim 20, wherein the user activatable input element comprises an electro-mechanical switch.

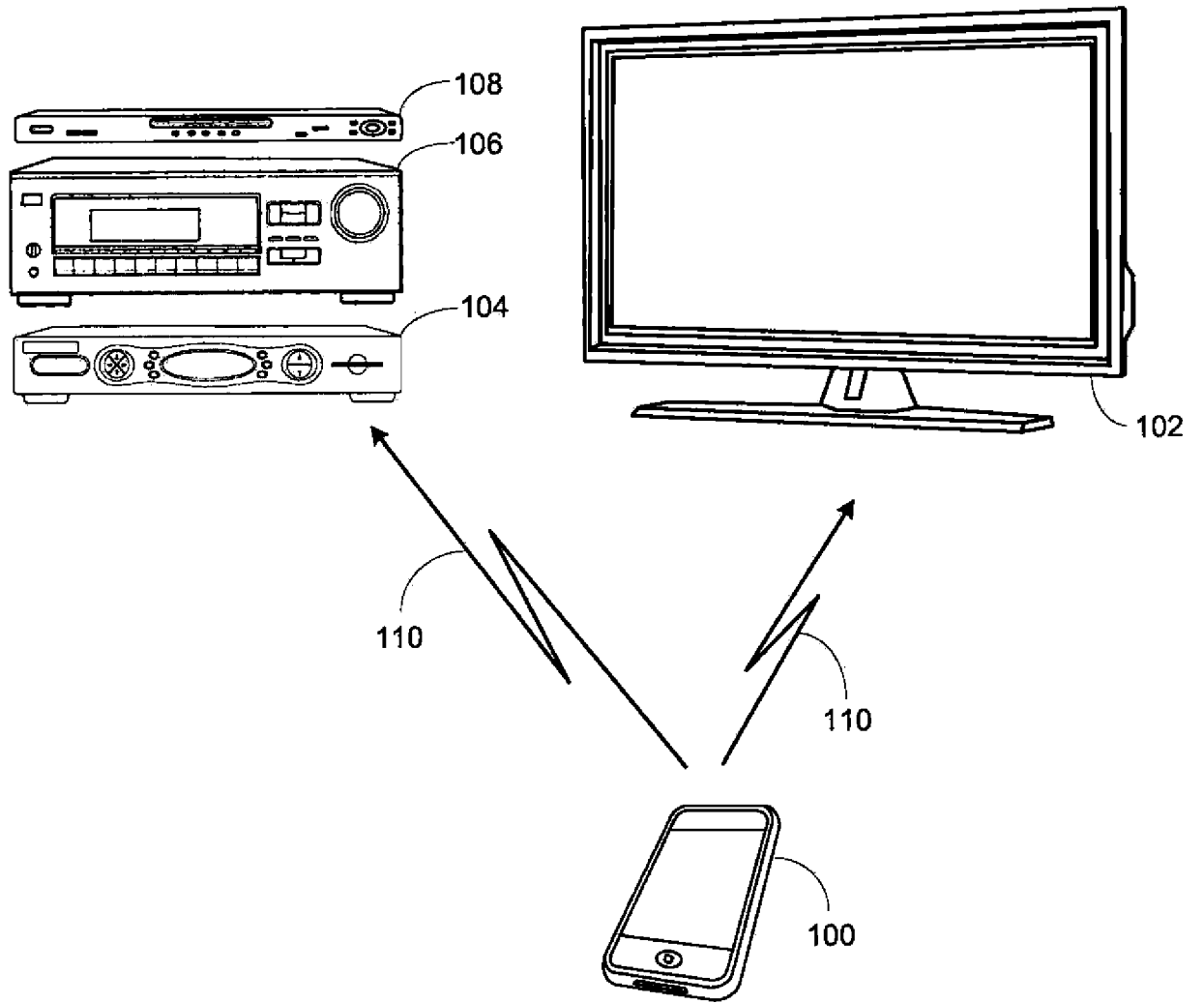

Figure 1

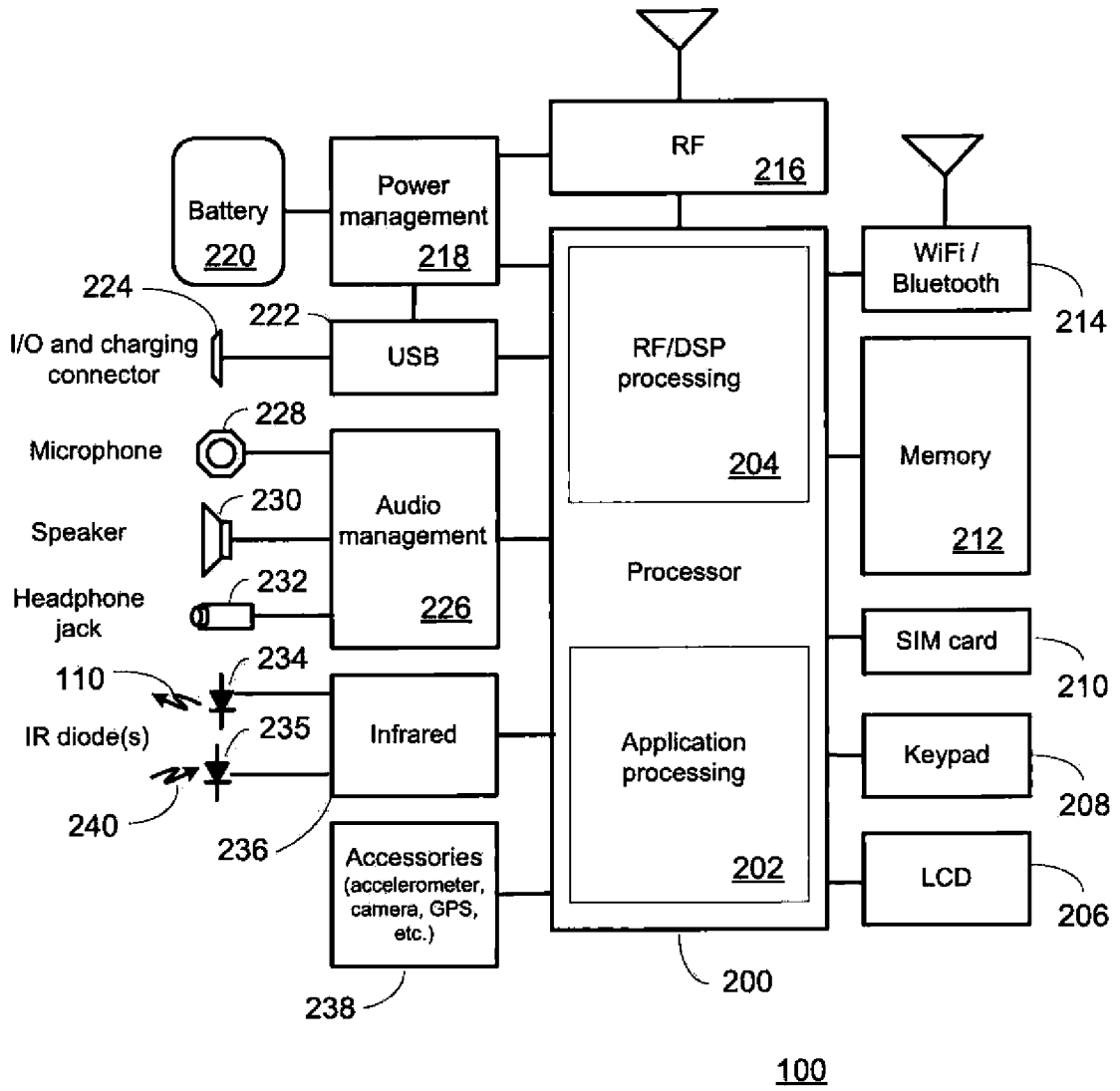

Figure 2

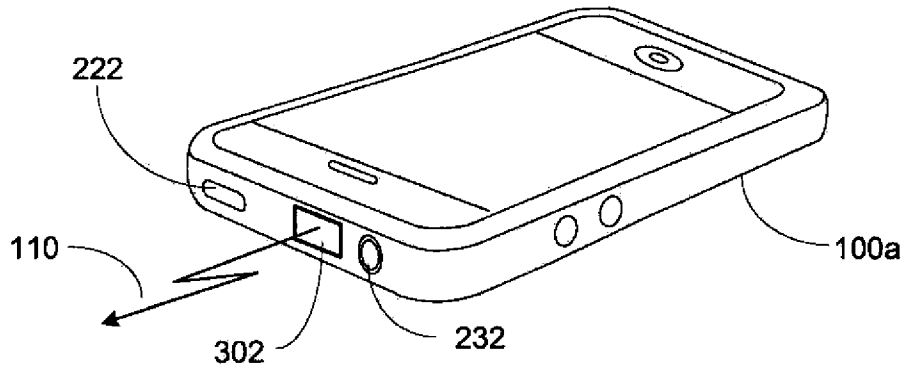

Figure 3a  
(Prior art)

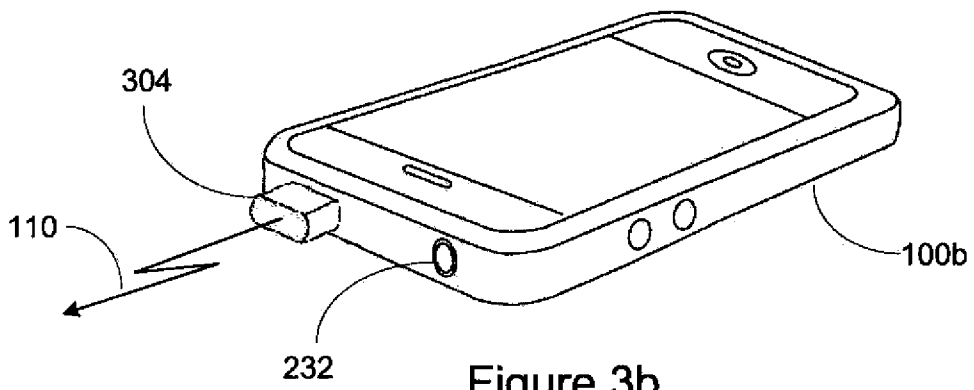

Figure 3b  
(Prior art)

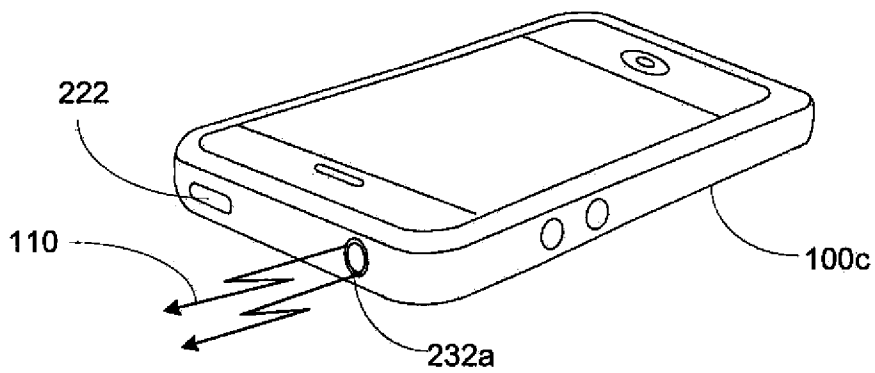
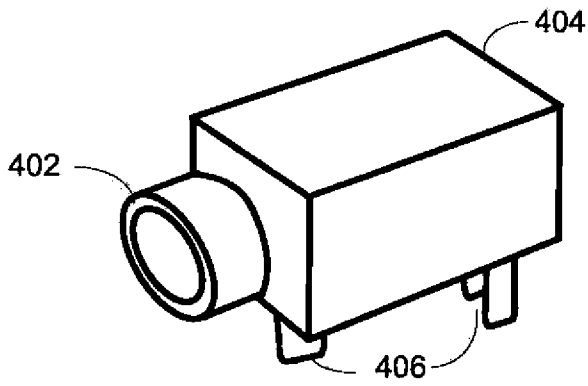
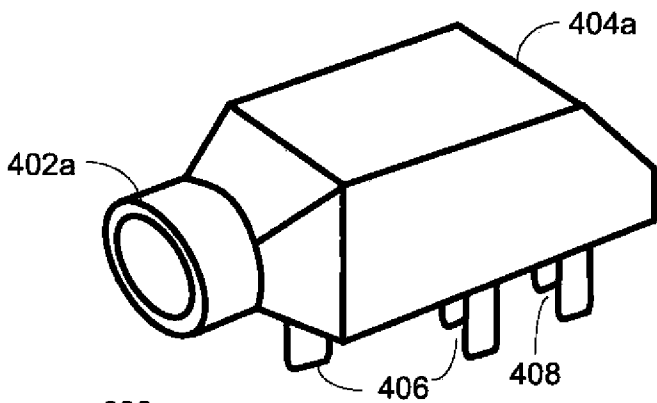
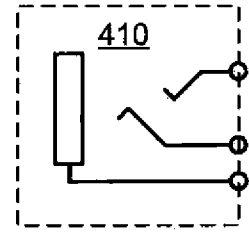

Figure 3c



232

Figure 4a  
(Prior Art)



232a

Figure 4b

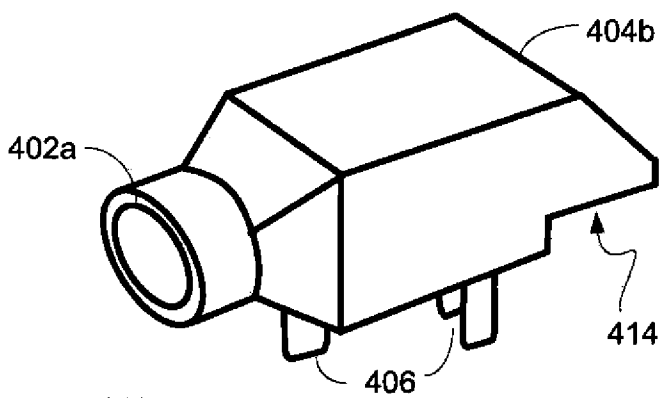
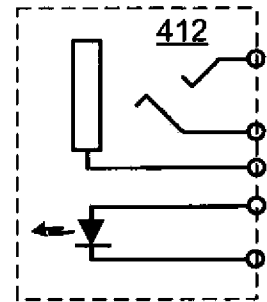

232a

Figure 4c

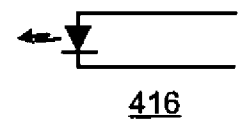
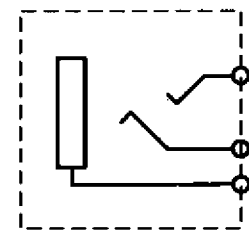

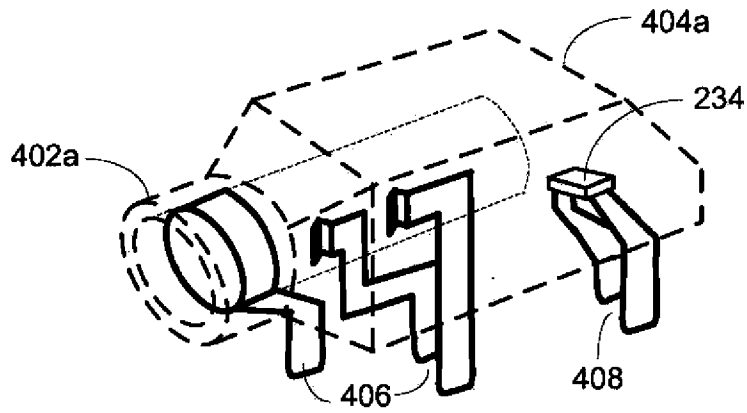

Figure 5a

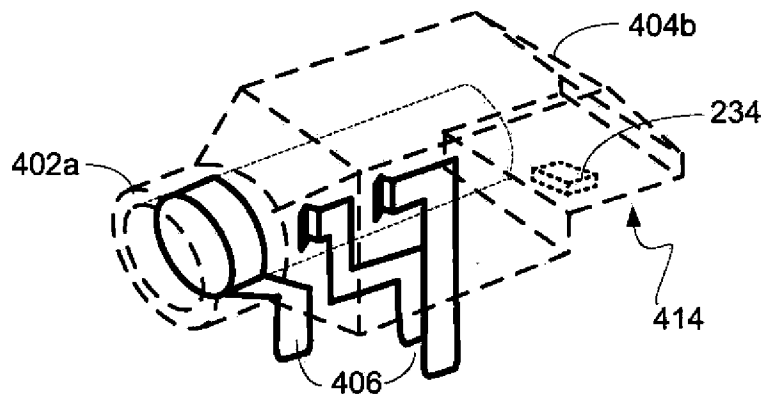

Figure 5b

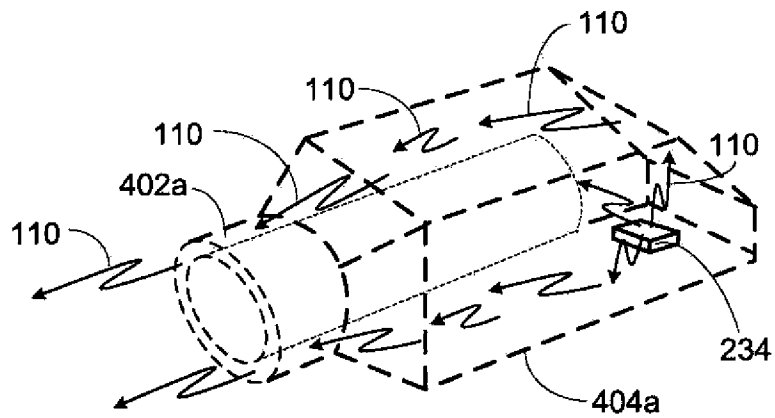
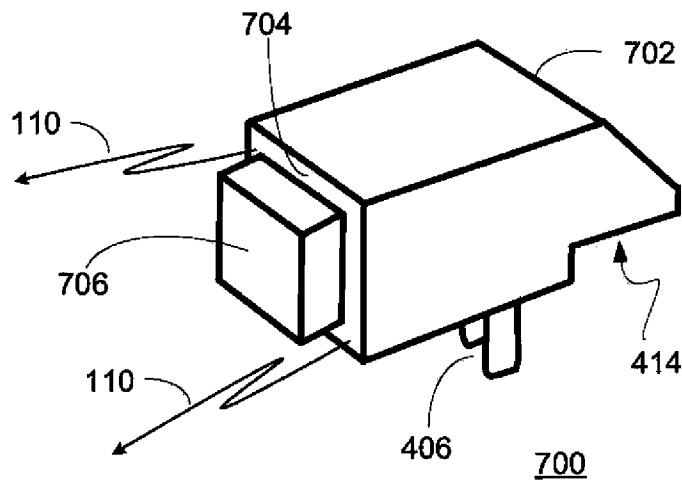
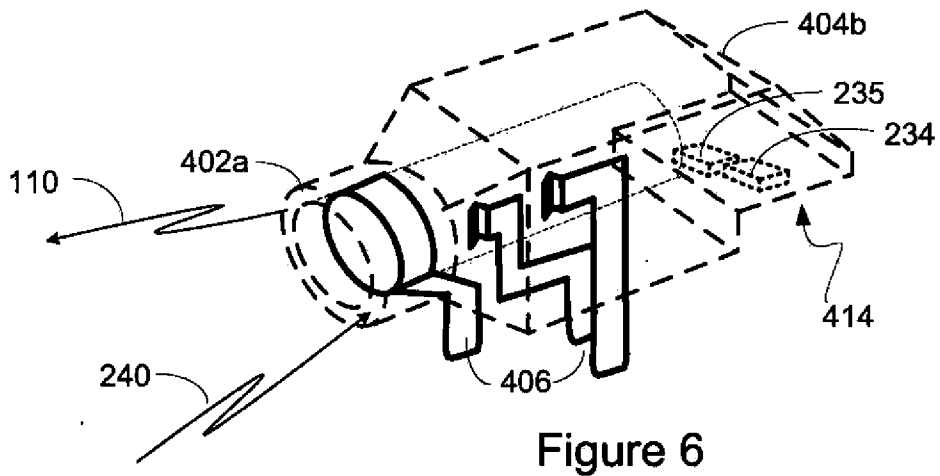

Figure 5c



**INTERNATIONAL SEARCH REPORT**

International application No.

PCT/US2012/024830

<p><b>A. CLASSIFICATION OF SUBJECT MATTER</b>                  IPC(8) - H04M 1/02 (2012.01)                  USPC - 455/556.1                  According to International Patent Classification (IPC) or to both national classification and IPC</p>																							
<p><b>B. FIELDS SEARCHED</b></p> <p>Minimum documentation searched (classification system followed by classification symbols)                  IPC(8) - H01R 33/945; H04B 10/04; H04M 1/02 (2012.01)                  USPC - 398/117, 139; 439/577; 455/552.1, 556.1</p> <p>Documentation searched other than minimum documentation to the extent that such documents are included in the fields searched</p> <p>Electronic data base consulted during the international search (name of data base and, where practicable, search terms used)                  PatBase, Google Patents, Google Scholar</p>																							
<p><b>C. DOCUMENTS CONSIDERED TO BE RELEVANT</b></p> <table border="1"> <thead> <tr> <th>Category*</th> <th>Citation of document, with indication, where appropriate, of the relevant passages</th> <th>Relevant to claim No.</th> </tr> </thead> <tbody> <tr> <td>X</td> <td>US 2009/0110404 A1 (AGEVIK) 30 April 2009 (30.04.2009) entire document</td> <td>12, 13, 19</td> </tr> <tr> <td>Y</td> <td></td> <td>1-11, 14-18, 20-21</td> </tr> <tr> <td>Y</td> <td>US 7,670,170 B2 (HENRY et al) 02 March 2010 (02.03.2010) entire document</td> <td>1-11, 14-18</td> </tr> <tr> <td>Y</td> <td>US 2008/0295017 A1 (TSENG et al) 27 November 2008 (27.11.2008) entire document</td> <td>10-11, 20-21</td> </tr> <tr> <td>A</td> <td>US 6,483,712 B1 (OLIPHANT et al) 19 November 2002 (19.11.2002) entire document</td> <td>1-21</td> </tr> <tr> <td>A</td> <td>US 2004/0043668 A1 (IKUTA) 04 March 2004 (04.03.2004) entire document</td> <td>1-21</td> </tr> </tbody> </table>			Category*	Citation of document, with indication, where appropriate, of the relevant passages	Relevant to claim No.	X	US 2009/0110404 A1 (AGEVIK) 30 April 2009 (30.04.2009) entire document	12, 13, 19	Y		1-11, 14-18, 20-21	Y	US 7,670,170 B2 (HENRY et al) 02 March 2010 (02.03.2010) entire document	1-11, 14-18	Y	US 2008/0295017 A1 (TSENG et al) 27 November 2008 (27.11.2008) entire document	10-11, 20-21	A	US 6,483,712 B1 (OLIPHANT et al) 19 November 2002 (19.11.2002) entire document	1-21	A	US 2004/0043668 A1 (IKUTA) 04 March 2004 (04.03.2004) entire document	1-21
Category*	Citation of document, with indication, where appropriate, of the relevant passages	Relevant to claim No.																					
X	US 2009/0110404 A1 (AGEVIK) 30 April 2009 (30.04.2009) entire document	12, 13, 19																					
Y		1-11, 14-18, 20-21																					
Y	US 7,670,170 B2 (HENRY et al) 02 March 2010 (02.03.2010) entire document	1-11, 14-18																					
Y	US 2008/0295017 A1 (TSENG et al) 27 November 2008 (27.11.2008) entire document	10-11, 20-21																					
A	US 6,483,712 B1 (OLIPHANT et al) 19 November 2002 (19.11.2002) entire document	1-21																					
A	US 2004/0043668 A1 (IKUTA) 04 March 2004 (04.03.2004) entire document	1-21																					
<p><input type="checkbox"/> Further documents are listed in the continuation of Box C. <input type="checkbox"/></p>																							
<p>* Special categories of cited documents:</p> <table border="0"> <tr> <td>“A” document defining the general state of the art which is not considered to be of particular relevance</td> <td>“T” later document published after the international filing date or priority date and not in conflict with the application but cited to understand the principle or theory underlying the invention</td> </tr> <tr> <td>“E” earlier application or patent but published on or after the international filing date</td> <td>“X” document of particular relevance; the claimed invention cannot be considered novel or cannot be considered to involve an inventive step when the document is taken alone</td> </tr> <tr> <td>“L” document which may throw doubts on priority claim(s) or which is cited to establish the publication date of another citation or other special reason (as specified)</td> <td>“Y” document of particular relevance; the claimed invention cannot be considered to involve an inventive step when the document is combined with one or more other such documents, such combination being obvious to a person skilled in the art</td> </tr> <tr> <td>“O” document referring to an oral disclosure, use, exhibition or other means</td> <td>“&amp;” document member of the same patent family</td> </tr> <tr> <td>“P” document published prior to the international filing date but later than the priority date claimed</td> <td></td> </tr> </table>			“A” document defining the general state of the art which is not considered to be of particular relevance	“T” later document published after the international filing date or priority date and not in conflict with the application but cited to understand the principle or theory underlying the invention	“E” earlier application or patent but published on or after the international filing date	“X” document of particular relevance; the claimed invention cannot be considered novel or cannot be considered to involve an inventive step when the document is taken alone	“L” document which may throw doubts on priority claim(s) or which is cited to establish the publication date of another citation or other special reason (as specified)	“Y” document of particular relevance; the claimed invention cannot be considered to involve an inventive step when the document is combined with one or more other such documents, such combination being obvious to a person skilled in the art	“O” document referring to an oral disclosure, use, exhibition or other means	“&” document member of the same patent family	“P” document published prior to the international filing date but later than the priority date claimed												
“A” document defining the general state of the art which is not considered to be of particular relevance	“T” later document published after the international filing date or priority date and not in conflict with the application but cited to understand the principle or theory underlying the invention																						
“E” earlier application or patent but published on or after the international filing date	“X” document of particular relevance; the claimed invention cannot be considered novel or cannot be considered to involve an inventive step when the document is taken alone																						
“L” document which may throw doubts on priority claim(s) or which is cited to establish the publication date of another citation or other special reason (as specified)	“Y” document of particular relevance; the claimed invention cannot be considered to involve an inventive step when the document is combined with one or more other such documents, such combination being obvious to a person skilled in the art																						
“O” document referring to an oral disclosure, use, exhibition or other means	“&” document member of the same patent family																						
“P” document published prior to the international filing date but later than the priority date claimed																							
<p>Date of the actual completion of the international search</p> <p>11 May 2012</p>	<p>Date of mailing of the international search report</p> <p><b>23 MAY 2012</b></p>																						
<p>Name and mailing address of the ISA/US</p> <p>Mail Stop PCT, Attn: ISA/US, Commissioner for Patents                  P.O. Box 1450, Alexandria, Virginia 22313-1450                  Facsimile No. 571-273-3201</p>	<p>Authorized officer:</p> <p>Blaine R. Copenheaver</p> <p>PCT Helpdesk: 571-272-4300                  PCT OSP: 571-272-7774</p>																						