

(19) World Intellectual Property Organization
International Bureau



(43) International Publication Date
9 July 2009 (09.07.2009)

PCT

(10) International Publication Number
WO 2009/086556 A1

(51) International Patent Classification:
G01N 29/02 (2006.01)

(21) International Application Number:
PCT/US2008/088665

(22) International Filing Date:
31 December 2008 (31.12.2008)

(25) Filing Language: English

(26) Publication Language: English

(30) Priority Data:
61/017,867 31 December 2007 (31.12.2007) US
61/137,027 25 July 2008 (25.07.2008) US

(74) Agents: WILLIAMS, JR., J. Roger et al.; Andrews Kurth LLP, 111 Congress Avenue, Suite 1700, Austin, Texas 78701 (US).

(81) Designated States (unless otherwise indicated, for every kind of national protection available): AE, AG, AL, AM, AO, AT, AU, AZ, BA, BB, BG, BH, BR, BW, BY, BZ, CA, CH, CN, CO, CR, CU, CZ, DE, DK, DM, DO, DZ, EC, EE, EG, ES, FI, GB, GD, GE, GH, GM, GT, HN, HR, HU, ID, IL, IN, IS, JP, KE, KG, KM, KN, KP, KR, KZ, LA, LC, LK, LR, LS, LT, LU, LY, MA, MD, ME, MG, MK, MN, MW, MX, MY, MZ, NA, NG, NI, NO, NZ, OM, PG, PH, PL, PT, RO, RS, RU, SC, SD, SE, SG, SK, SL, SM, ST, SV, SY, TJ, TM, TN, TR, TT, TZ, UA, UG, US, UZ, VC, VN, ZA, ZM, ZW.

(84) Designated States (unless otherwise indicated, for every kind of regional protection available): ARIPO (BW, GH, GM, KE, LS, MW, MZ, NA, SD, SL, SZ, TZ, UG, ZM, ZW), Eurasian (AM, AZ, BY, KG, KZ, MD, RU, TJ, TM), European (AT, BE, BG, CH, CY, CZ, DE, DK, EE, ES, FI, FR, GB, GR, HR, HU, IE, IS, IT, LT, LU, LV, MC, MT, NL, NO, PL, PT, RO, SE, SI, SK, TR), OAPI (BF, BJ, CF, CG, CI, CM, GA, GN, GQ, GW, ML, MR, NE, SN, TD, TG).

(71) Applicant (for all designated States except US): O. I. CORPORATION [US/US]; 151 Graham Road, P.O. Box 9010, College Station, Texas 77842-9010 (US).

(72) Inventors; and

(75) Inventors/Applicants (for US only): ERICKSON, Gary L. [US/US]; 3003 Aztec St., College Station, Texas 77845 (US). RANGER, Craig [US/US]; 6901 N. Rockledge Ave., Glendale, Wisconsin 53209 (US).

Published:
— with international search report
— with amended claims

(54) Title: SYSTEM AND METHOD FOR REGULATING FLOW IN FLUIDIC DEVICES

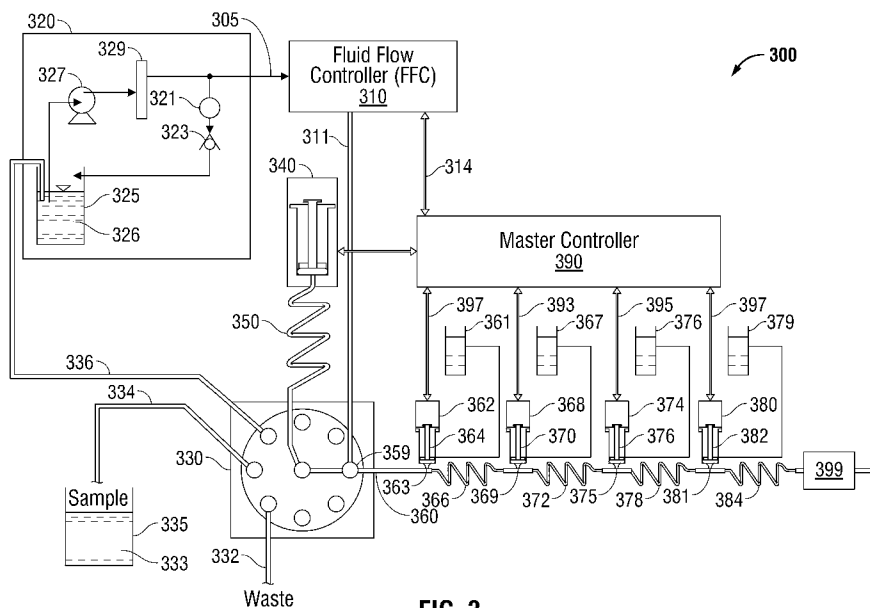

FIG. 3

(57) Abstract: Disclosed are a system and method for regulating flow in an exemplary fluidic device comprising a fluidic stream carrying a transport medium, sample and one or more reagents for analysis and synthesis of reaction products. The flow rate of the fluidic stream is maintained constant by adjusting the flow rate of transport medium to compensate for the introduction of sample and reagents. An embodiment controls the flow rate of transport medium using a pump, a back pressure regulator, and a variable-sized orifice. Single and multiple channel embodiments are disclosed.

WO 2009/086556 A1

SYSTEM AND METHOD FOR REGULATING FLOW IN FLUIDIC DEVICES**CROSS-REFERENCE TO RELATED APPLICATIONS**

[001] This application claims the benefit of U.S. Provisional Application No. 61/017,867
5 filed on 31 December 2007, which is hereby incorporated by reference. This application
further claims the benefit of U.S. Provisional Application No. 61/137,027 filed on 25 July
2008, which is hereby incorporated by reference.

BACKGROUND OF THE INVENTIONField of the Invention

10 [002] This invention relates to the field of flow regulation in fluidic devices. Specifically,
this invention relates to the field of flow regulation in fluidic devices used in the field of
chemical synthesis and analysis.

Background of the Invention

15 [003] Many different methods have been developed for sample preparation, chemical
synthesis and chemical analysis. Typical methods include continuous flow analysis and
discrete batch analysis. Continuous flow analysis includes establishing a sample pipeline to
enable high sample throughput independent of the complexity of the reaction. For instance,
continuous flow analysis includes the ability to perform in-line sample treatments such as
20 distillation, digestion, dialysis and solvent extraction in addition to performing complex
reactions requiring the sequential addition of multiple reagents. Continuous flow sample
processing enables a pipeline to be established which requires a defined amount of time for a
reaction followed by processing of one sample within a defined cycle period which is
significantly shorter than the reaction time for complex reactions. The major drawbacks to
continuous flow analysis include the lack of ability to program tests per sample and excessive
25 reagent usage as they are pumped continuously during the analytical process.

[004] Beyond the analytical difficulties with current methods, continuous flow instruments
are negatively impacted by the use of peristaltic pumps to provide motive force for samples
and reagents. These pumps limit the performance of continuous flow systems through the
peristaltic action that is an intrinsic characteristic of peristaltic pumps. This action causes
30 pulsations in the fluid path that may adversely affect the accurate quantification of analytes
passing through the fluidic device to a sample detector. Although they are relatively
inexpensive, peristaltic pumps can be problematic for common applications involving sample

measurements. For example, the tubing for each of the analytical streams or channels must frequently be replaced, which requires a subsequent clean-up process. Sizing issues must also be rectified in order to achieve proper quantitative "mixing" of analyte and reagents both spatially and volumetrically. Peristaltic pumps typically have a limited number of analytical channels, which each have a limited relative volume. Furthermore, the tubing used in peristaltic pumps often fails due to collapse (i.e., loss of elasticity). This tubing failure generates uneven, or non-reproducible flows, for the different channels of analyte and/or reagents being transported.

[005] Other pumps are also not particularly suitable for a variety of reasons. For example, replacing peristaltic pumps with syringe pumps is very expensive. Moreover, other types of air displacement pumps are not suitable replacements for peristaltic pumps, because they have problems with gas solubility (e.g., air bubbles coming out of solution in the detector) and gas compressibility in the analyte transport process.

[006] Discrete batch analysis operates by adding only the exact amount of reagents required per test per sample, which allows for automated test selection per sample and significant reduction in reagent usage. For instance, discrete batch analysis includes minimizing sample volumes, reagent volumes, and waste generation as well as providing a higher level of automation than continuous flow analysis in test profiling per sample and automated method switching. However, discrete batch analysis has major drawbacks that include (a) decreased sample throughput or number of tests per hour since each sample reaction sequence is treated discretely or independently thereby not enabling a pipeline to be established; and (b) the inability to perform in-line sample preparation.

BRIEF SUMMARY OF EMBODIMENTS

[007] Disclosed is a system and method of regulating the flow of a fluidic device. An exemplary fluidic device is an analytical detector, and the system and method described herein can be used to provide constant sample flow at a sample detector. The system uses one or more controllers to monitor and control the addition of transport medium, sample, and reagents to one or more analytical streams in order to maintain a constant flow of the analytical streams at one or more analytical detectors. Typically, the flow rate through the analytical stream is controlled by the controllers to properly sequence the addition of the sample and one or more reaction reagents and to permit one or more reaction processes prior to constant flow analysis by the detectors. Embodiments of the system and method provide a sample pipeline with high sample throughput independent of the complexity of the reaction, without the disadvantages of

peristaltic pumps or excessively wasteful flow quantities of sample or reagent. Embodiments allow for the dynamic injection of samples and reagents into the sample pipeline on an analysis-by-analysis basis where sample and and/or reagent volumes can be optimized for the specific measurement. The result embodies an automated device that, like a discrete batch analysis method, provides a high level of automation, minimizes sample volumes, reagent volumes, and waste generation, while maintaining the continuous flow sample pipeline and throughput capabilities of continuous flow analysis.

[008] An exemplary implementation of the system comprises one or more analytical streams flowing through a pumping system and flow control module, a sample introduction module, a sample reaction module, and a sample detection module. An exemplary pumping system and flow control module comprise a pump, a back pressure regulator and one or more fluidic flow controllers. The pump draws transport medium from a reservoir and directs it to the one or more analytical streams. The back pressure regulator positioned downstream of the pump maintains a constant pressure of the transport medium to each of the analytical streams. The fluidic flow controller maintains a constant flow rate of transport medium in each of the analytical streams. In one implementation of the system, the sample introduction module comprises a syringe pump and an isolation loop. In an embodiment, the sample reaction module includes inlets for the introduction of reagents into the analytical streams and one or more reaction devices, some of which may be user-configurable. The pumping system and flow control module reduce the flow rate of transport medium to compensate for the introduction of sample and reagents into the analytical streams, thereby maintaining a constant flow at the sample detection module.

[009] Also disclosed is a system comprising one or more fluidic carrier streams, a first injection means for injecting a first substance into a carrier stream to make a first stream, a second injection means for injecting a second substance into the first stream to make a second stream, and a flow regulator that maintains the second stream at a constant flow rate by adjusting the flow rate of the carrier stream to compensate for the introduction of the first and second substances. An embodiment of the system comprises a fluidic flow controller comprising an orifice.

[0010] Also disclosed is an embodiment of a system for intermittent introduction of sample and reagent(s) into a continuously flowing carrier stream. The system includes a means to propel the carrier stream by a non-pulsatile mechanism, a sample injection valve to introduce the sample into the carrier stream and a means to introduce discrete aliquots of reagents into the continuously flowing stream at pre-programmed intervals. The non-pulsatile characteristic

of the carrier stream pumping mechanism of the system allows the location of the sample within the carrier stream to be known at any time following sample introduction into the carrier stream. At least one reagent is added to the sample in the carrier stream when the sample carrier stream is disposed at a desired location in the sample and reagent addition system.

5 [0011] Also disclosed is a system comprising a constant flow pump to deliver a transport medium to a manifold, a back pressure regulator that maintains constant pressure at the manifold, transport medium flowing through the manifold via a flow element, and a valve in the flow element to control the flow of transport medium thereby creating an analytical stream. The system also includes a syringe pump that injects a volume of sample into the analytical stream downstream of the valve, at least one reagent inlet for injecting a reagent into the
10 analytical stream, at least one mixing volume downstream of the reagent inlet, the mixing volume arranged and designed to permit a reaction between said reagent and said sample to create a reaction product, a detector to analyze the reaction product, and a flow controller that controls the valve, the syringe pump, and the reagent injection such that a constant flow of the
15 analytical stream containing the reaction product is delivered to the detector.

[0012] Also disclosed is a method for regulating flow in a fluidic device comprising delivering a fluidic carrier stream at a substantially constant flow rate, introducing first and second substances into the carrier stream to make a second stream having a second stream flow rate, and regulating the carrier stream flow rate so that the second stream flow rate remains
20 substantially constant.

[0013] The foregoing has outlined rather broadly the features and technical advantages of the present invention in order that the detailed description of the invention that follows may be better understood. Additional features and advantages of the invention will be described hereinafter that form the subject of the claims of the invention. It should be appreciated by
25 those skilled in the art that the conception and the specific embodiments disclosed may be readily utilized as a basis for modifying or designing other embodiments for carrying out the same purposes of the present invention. It should also be realized by those skilled in the art that such equivalent embodiments do not depart from the spirit and scope of the invention as set forth in the appended claims.

30 **BRIEF DESCRIPTION OF THE DRAWINGS**

[0014] For a detailed description of the preferred embodiments of the invention, reference will now be made to the accompanying drawings in which:

[0015] Figure 1 illustrates an embodiment of a sample and reagent addition process having distributed flow.

[0016] Figure 2 illustrates an embodiment of the process of Figure 1 having a downstream pump.

5 [0017] Figure 3 illustrates an embodiment of a system for regulating flow in a fluidic device.

[0018] Figure 4 illustrates an exemplary embodiment of a fluidic flow controller.

[0019] Figure 5 illustrates exemplary flow rates in a system for regulating flow in a fluidic device with a single flow stream comprising a transport medium and a sample.

10 [0020] Figure 6 illustrates exemplary flow rates in a system for regulating flow in a fluidic device with a single flow stream comprising a transport medium and a sample and one reagent.

[0021] Figure 7 illustrates exemplary flow rates in a system for regulating flow in a fluidic device with a single flow stream comprising a transport medium and a sample and four reagents.

15 [0022] Figure 8 illustrates an exemplary simple sequence of flow rates in a system for regulating flow in a fluidic device with a single flow stream comprising a transport medium and a sample and four reagents.

[0023] Figure 9 illustrates exemplary flow rates during an oversampling sequence in a system for regulating flow in a fluidic device with a single flow stream comprising a transport medium and a sample and four reagents.

20 [0024] Figure 10 illustrates an exemplary embodiment of a system for regulating flow in a fluidic device comprising a pumping system and flow control module, a sample introduction module, a sample reaction module, and a sample detection module.

[0025] Figure 11 illustrates an exemplary implementation of a flow control module in a system for regulating flow in a fluidic device.

25 [0026] Figure 12 illustrates an exemplary embodiment of a sample introduction module in a system for regulating flow in a fluidic device.

[0027] Figure 13 illustrates an alternative embodiment of a sample introduction module in a system for regulating flow in a fluidic device.

30 [0028] Figure 14 illustrates a exemplary implementation of a sample reaction module and a sample detection module in a system for regulating flow in a fluidic device.

[0029] Figures 15A-E depict an exemplary embodiment of a valve adapted for use in a method and system for regulating flow in a fluidic device.

DETAILED DESCRIPTION OF THE PREFERRED EMBODIMENTS

[0030] Figure 1 illustrates a process and system for regulating flow in an exemplary fluidic device comprising a sample and reagent addition process 105 including pump 110, sample addition point 112, and reagent addition points 115, 120 and 125. Pump 110 may include any pump suitable for pumping a liquid provided that it is sufficiently accurate and precise in operation to position the sample zone in both a known and reproducible fashion to enable the overlay or merging of subsequent reagent aliquots into the sample zone. In the preferred embodiment, pump 110 includes a non-peristaltic non-pulsatile pump with high accuracy and precision in terms of flow rate against variable backpressures. An exemplary pump 110 is an electronically adjustable rotary pump. It is to be understood that sample and reagent addition process 105 is not limited to three reagent addition points 115, 120 and 125 but may have more or less than such three reagent addition points.

[0031] As shown in Figure 1, sample and reagent addition process 105 includes carrier stream 130. Carrier stream 130 includes any fluid suitable for transport of sample 135 and reagents 145, 155 and 165. In an embodiment, carrier stream 130 includes a fluid that is non-reactive with sample 135 and reagents 145, 155 and 165. In some embodiments, carrier stream 130 is deionized water. In some embodiments, carrier stream 130 is continuously pumped through a fluidic conduit using pump 110, which in some embodiments is a non-pulsatile pump. The fluidic conduit may include any suitable piping or tubing having any suitable bore diameter. In an embodiment, the bore has a diameter from about 0.1 mm to about 1.0 mm. In an embodiment, sample 135 is introduced to carrier stream 130 downstream of pump 110 at sample addition point 112 to create a sample zone within the carrier stream 140. In an embodiment, reagent addition is made at reagent addition point 115 concurrent with the sample carrier stream 140 passing reagent addition point 115. At reagent addition point 115, reagent 145 may be added to sample carrier stream 140 to provide stream 150. Stream 150 may then be provided to reagent addition point 120 at which reagent 155 may be added to provide stream 160. Stream 160 may be provided to reagent addition point 125 at which reagent 165 may be added to provide reaction product 170. In some embodiments, sample and reagent addition process 105 is automatically controlled such as by a computer system.

[0032] As further shown in Figure 1, sample 135 may be added to sample addition point 112, and reagents 145, 155 and 165 may be introduced to the respective reagent addition points 115, 120 and 125 by any suitable method and device. Examples of such suitable methods include bolus injection or by continuous addition. In an embodiment, a suitable method is continuous

addition. In such an embodiment, the addition point (e.g., sample addition point 112 or reagent addition points 115, 120 or 125) includes a tee fitting. In alternative embodiments, the addition point includes a valve or pump to enable non-continuous, intermittent and precise reagent introduction into the sample carrier stream. In some embodiments, the valve is a two-position valve with a load position and an injection position. In some embodiments, the pump is capable of rapid on-off cycling with no significant hysteresis.

[0033] In alternative embodiments, any of streams 130, 140, 150, 160 and 170 may be segmented with an alternative phase. The alternative phase may be gas or liquid. In some alternative embodiments, segmentation may be performed at any position along the flow path (e.g., before or after sample introduction). In other alternative embodiments, any of streams 130, 140, 150, 160 and 170 may be de-segmented at any position along the flow path. In addition, alternative flow regimes may be provided at any position along the flow path for any streams 130, 140, 150, 160 and 170. For instance, alternative flow regimes such as, without limitation, bolus flow, laminar flow, turbulent flow, or any combinations thereof may be provided at any position along the flow path.

[0034] Sample 135 and reagents 145, 155 and 165 may be added at any angle to the respective stream flow. In an embodiment, sample 135 and reagents 145, 155 and 165 are added at about a 90° angle to the flow path of the respective stream.

[0035] It is to be understood that as the sample proceeds through the fluidic conduit, the characteristics of pump 110 may enable the location of the sample zone within the reaction conduits to be known at any given time. For instance, the continuous and non-pulsatile flow allows the sample location within sample and reagent addition process 105 to be known at any time, which allows the proper time at which to add a reagent to be known. It is to be further understood that sample and reagent addition process 105 provides a pulsed or intermittent addition of liquids or gases to a carrier stream (e.g., carrier stream 130) through an addition point (e.g., either a valve or a tee fitting). In such embodiments, successive liquid boluses may be overlaid onto an existing zone. For instance, such an overlay may allow reagent addition in precise quantities and in sufficient volumes for a particular reaction. In addition, the sample/carrier stream (e.g., sample carrier stream 140) may also encounter a solid phase such as an ion exchange, extraction, reduction or oxidation column, a wet or diffusion-based distillation device, a phase combination device, a phase separation device, a heat-based and/or a light-based digestion device and a dialysis device.

[0036] It is to be further understood that sample and reagent addition process 105 includes a mixing stage after each addition point. In some embodiments, the distance between the

addition points along the flow path is selected to allow a desired mixing of the reagents and sample.

[0037] In an alternative embodiment, the exemplary sample and reagent addition process 105 includes at least one additional pump downstream of pump 110. Figure 2 illustrates an embodiment in which an exemplary sample and reagent addition process 205 includes pump 275 downstream of pump 210 and upstream of reagent addition point 220. Sample and reagent addition process 205 may also or alternatively include a pump upstream of reagent addition points 215 and/or 225.

[0038] In some embodiments, sample and reagent addition process 205 includes a method comprised of a carrier stream (or alternatively a propulsion stream) driven forwards and backwards in fluidic conduits by a highly precise pump and one or more additional pumps downstream, operating independently or in series. Such pumps allow for the addition of chemicals (e.g., either continuously or intermittently) to achieve a goal of a selected technique. Without limitation, such techniques may include preparation of a sample using distillation, digestion, dilution, dialysis, solvent extraction, ion exchange, field flow fractionation and derivatization of selected analytes contained in a sample to generate a reaction product that may be subsequently delivered to a detector. Examples of detectors include spectrophotometers and electrochemical detectors for quantification and small scale chemical synthesis.

[0039] Sample and reagent addition processes 105, 205 provide a method for the purpose of chemical synthesis, including, but not limited to reaction products quantifiable for analytical purposes, manipulation of cells and bacteria, manipulation of multi-phase streams, ion exchange for both sample preparation and separation applications and field flow fractionation for either sample preparation or separation.

[0040] To further illustrate various illustrative embodiments of the present invention, the following examples are provided.

EXAMPLE

[0041] An example application of sample and reagent addition process 105 is in the determination of nitrate in water samples. In preparation for sample processing, a carrier stream was aspirated into a syringe through a valve aligned with a reservoir of deionized water. The valve was then switched to place the syringe in-line with the primary fluidic conduit, and the carrier was pumped downstream through the entire fluidic conduit and into a flow cell

where a water baseline was established. This apparatus corresponded with pump 110 in Figure 1.

[0042] Once the water baseline was established, the sample was injected into the carrier stream at sample addition point 112 in Figure 1. Subsequently, a quantity, of ammonium chloride (R1) was pulsed into the carrier stream on top of the sample zone in the carrier as it passed reagent addition point 115 in Figure 1 and pumped into a mixing device and a reaction device. The carrier/R1 combination was then pumped through a conduit coated with cadmium to reduce nitrate to nitrite corresponding to stream 150 in Figure 1. Upon exiting from the cadmium reduction section, a quantity of naphthylthylenediamine dihydrochloride (R2) was pulsed into the sample/ammonium chloride stream as such combination passed the R2 inlet at reagent addition point 120 in Figure 1, which was then directed through a second mixing and reaction device for the purpose of derivatizing the nitrite to generate a colored reaction product. In this example, a third reagent was not required to be added at reagent addition point 125. The absorbance of the reaction product was read at 520 nm to establish a reagent baseline. In the absence of the addition of a sample zone, such mixture yielded a reagent blank.

[0043] Once the reagent baseline (blank) was established, a quantity of sample was introduced into the carrier, and R1 was pulsed into the sample zone in the carrier followed by mixing and reaction. The buffered sample was then pumped through the cadmium reduction conduit followed by addition of R2 to the buffered sample zone and mixing and reaction of R2 with the buffered sample zone. The reaction product was pumped into the absorbance detector flow cell where a transient signal was generated as the transmittance of the light in the flow path was decreased resulting in a transient peak, which represented the distribution of the sample/R1/R2 zones in the carrier and the height and area of which were directly proportional to the quantity of nitrate and nitrite present in the original sample based on a calibration curve.

[0044] An embodiment of a system and method for regulating flow to an fluidic device utilizes an electronic controller to integrate one or more fluidic flow controllers and any number of substance introducers (e.g., injectors) based on an algorithm that ensures the total flow rate remains nearly or substantially constant during the injection of samples or reagents into the flow stream. The controller (a personal computer or imbedded microprocessor properly programmed) controls the independent device timing to maintain the final flow rate at the detector. This front end flow control allows the sensitive and expensive flow sensor in the fluidic flow controller (FFC) to be located where it is only exposed to inert transport medium avoiding corrosive reagents and the possibility of plugging from sample particulates.

[0045] The flow rate in a channel can be described generally by the equation:

$$F_{\text{total}} = F_{\text{TM}} + F_{\text{inj } 1} + F_{\text{inj } 2} + F_{\text{inj } 3} \dots + F_{\text{inj } n} \quad (1)$$

Where:

$$F_{\text{total}} \text{ (or Total Flow)} = \text{Total flow rate of the system} \quad (2)$$

$$F_{\text{TM}} = \text{Flow rate of the transport medium} \quad (3)$$

$$F_{\text{inj } j} = \text{the flow rate added by injector } j \text{ (for } j = 1 \text{ to } n) \quad (4)$$

[0046] The basic equation preferably ignores the detail of the acceleration/deceleration profiles of the injectors and the FFC because it is assumed in an embodiment that the acceleration/deceleration profile of the FFC will be the inverse of the acceleration/deceleration profile of the injectors.

[0047] Figure 3 illustrates an embodiment of a system 300 for regulating flow in a fluidic device having a single channel. Preferably the total flow rate of the system (F_{total}) remains constant or substantially constant throughout the processing of samples. F_{target} refers to the target total flow rate. An exemplary target total flow rate in an embodiment is 2000 μ L/minute. Embodiments of system 300 can accommodate greater or lesser volumes and flow rates. Preferably system 300 can accommodate flow rates associated with analysis in the range of nanoliters to centiliters per minute.

[0048] System 300 provides a two-part pump system which includes a constant pressure system 320 and a fluidic flow controller (FFC) 310 which utilizes a voltage-controlled orifice (VCO) to vary flow. The combination of constant pressure system 320 and FFC 310 perform the function of pump 110 illustrated in Figs. 1 and 2.

[0049] As illustrated in Figure 3, constant pressure system 320 preferably comprises a pump 327, a filter element 329, a transport conduit 305, a pressure sensor 321, a back pressure regulator 323, and a reservoir 325 containing a transport medium 326. Pump 327 draws transport medium 326 from reservoir 325 and directs it to a transport conduit 305, at a flow rate that exceeds the total flow requirement of the stream. Pump 327 is a pump such as an electronically adjustable rotary pump but may be another form of pump, preferably non-peristaltic or any other suitable device known to those of skill in the art that can provide constant pressure and adequate flow to transport conduit 305. The transport medium 326 is preferably a highly purified water (i.e., de-ionized water), however, alternative transport media may include perfluorinated polyether (PFPE) (i.e., Krytox® by Dupont), multiply-alkylated cyclopentanes (i.e., Pennzane® by Royal Dutch Shell), or any other highly hydrophobic fluid. Pump 327 preferably maintains a flow rate across filter element 329 that is positioned between

the pump 327 and transport conduit 305. Filter 329 eliminates any particulates which may interfere with the operation of the variable orifice or contribute error to the analysis. Filter 329 can be any type of particulate filter, preferably in the 5 micron filtering range.

5 [0050] Back pressure regulator 323 preferably is disposed in a side stream positioned downstream of the pump 327 between the filter element 329 and transport conduit 305. The back pressure regulator 323 maintains the transport medium at a constant pressure in transport conduit 305 and minimizes any pulsation or other flow irregularities from pump 327. In an embodiment, the preferred constant pressure is 20 psig, and the back pressure regulator 323 preferably maintains the pressure at 20 psig such that the pressure to the transport conduit 305 is also maintained at 20 psig. Back pressure regulator 323 preferably operates by permitting 10 the flow of transport medium therethrough at a varying flow rate to maintain the back pressure at a desired level. Any excess transport medium 326 flowing through back pressure regulator 323 is returned to the reservoir 325 for reuse. The output signal from pressure sensor 321, positioned between the filter element 329 and the back pressure regulator 329, is used to verify 15 performance of pump 327 either manually or through automatic feedback control. Preferably pressure sensor 321 is used to determine the supply side pressure in transport conduit 305. As is well known in the art, the differential pressure between the supply side pressure in transport conduit 305 and the flow side conduit 311 may be used to determine the flow rate in flow side conduit 311.

20 [0051] Figure 4 illustrates an embodiment of FFC 310 including a Voltage Controlled Orifice (VCO) 410, controller 420, capillary tube 430, and differential pressure sensor 440. The pump 327 and back flow regulator 323 of exemplary constant pressure system 320 provide constant pressure for the FFC 310 which varies the size of the VCO 410 at a fixed pressure to generate a particular flow. Additionally the back pressure regulator 323 dampens any pulsations generated 25 by the pump 327 thereby enhancing control by the FFC 310. In this case the VCO 410 separates transport conduit 305 and flow side conduit 311, so varying the orifice size with constant pressure varies the flow rate in flow side conduit 311. In an alternative embodiment, the size of the orifice in VCO is fixed and pump 327 can deliver controllably variable pressure (for example, under the control of controller 420. In this alternative embodiment, controller 30 420 can regulate the flow rate through the fixed orifice by controllably varying the pressure through the fixed orifice. As described in more detail below, transport medium 326 in flow side conduit 311 provides a carrier stream which in an embodiment will be combined with sample and reagent for analysis by a downstream detector or synthesis.

[0052] Controller 420 adjusts VCO 410 to regulate the flow of transport medium 326 from transport conduit 305 into flow side conduit 311. Additions of sample or reagents increase or decrease the flow rate in analytical stream 360, and in an embodiment master controller 390 directs controller 420 to adjust VCO 410 to compensate for the addition of sample or reagent to ensure that the flow rate in analytical stream 360 remains constant or substantially constant. The flow rate of transport medium 326 through FFC 310 is monitored by measuring the differential pressure across capillary tube 460. In another embodiment a single pressure sensor positioned to measure the pressure in flow side conduit 311 could be used in concert with pressure sensor 321 positioned to measure the pressure in transport conduit 305 to determine the flow rate in conduit 311. The differential pressure across capillary tube 460 is sensed by differential pressure sensor 440, which preferably includes an analog-digital converter (not numbered). The output from pressure sensor 440 is input into controller 420 which controls the voltage applied to VCO 410 located upstream from capillary tube 460. In an embodiment the signal from pressure sensor 440 is filtered to remove interference. VCOs (or equivalent variable-sized orifices), fixed orifice elements, capillary tubes and pressure sensors are well-known and readily available to those of skill in the art.

[0053] Controller 420 preferably includes a programmable interface controller including a CPU, input/output ports and means for controlling same such as a USART, on-board data space or RAM, memory, and code space or control software, preferably implemented an EPROM, ROM or Flash ROM, that includes instruction codes which when processed by the CPU cause controller 420 to perform the algorithms and methods described herein. An exemplary programmable interface controller is the PIC 18F4520 made by MicroChip Technology, which can be adapted for use in embodiments described herein with development tools such as MPLAB. In an embodiment controller 420 uses a loop control feedback process, preferably a proportional-integral-derivative (PID) control process based on flow rate readings obtained through capillary tube 430 and pressure sensor 440 to change the voltage supplied to VCO 410. Controller 420 preferably uses pulse width modulation (PWM) to control VCO 410. In an embodiment controller 420 includes a control line to control pump 327.

[0054] In an embodiment FFC 310 is a slave in a master-slave configuration with master controller 390 and controller 420 receives control input via control line 314 from master controller 390. Preferably master controller 390 provides a control signal indicating the desired flow rate, or alternatively a desired change in flow rate, for transport medium 326 in flow side conduit 311. Controller 420 responds to the control signal from control line 314 by adjusting the size of the orifice in VCO 410 to adjust the flow rate of transport medium 326 in

flow side conduit 311. The control signal to FFC 310 may be analog, for example a voltage between 0 and 5 volts dc, or a command issued over a serial link. In an alternative embodiment, controller 420 is integrated with master controller 390, through, for example, common hardware resources and/or common control software. In another alternative
5 embodiment, controller 420 receives control information directly from pump 340 and injectors 364, 370, 376 and 382 by, for example, a serial link or an analog signal line.

[0055] Exemplary system 300 includes a valve 330 to enable controlled introduction of fluid into analytical stream 360. Valve 330 preferably is a multi-port valve that provides ports to accommodate at least at least one analytical stream along with sample, transport media and
10 waste. In an embodiment valve 330 is an 8-port rotary valve such as, preferably, a Cavro XL 3000, which allows for up to five analytical streams (only one of which is illustrated in exemplary system 300 in Fig. 3). Valve 330 includes output ports connected to analytical stream 360 and waste disposal line 332. Valve 330 includes input ports connected to transport line 336 carrying transport medium from reservoir 325 and sample line 334 carrying sample
15 333 from sample reservoir 335. In an embodiment the motive force for moving fluid through valve 330 is provided by pump 340 connected via isolation loop 350 to a common port (*e.g.*, center port) of valve 330. Flow side conduit 311 carries transport medium 326 through one arm of "Tee" 359 connected to a port of the valve 330 and out the other arm into analytical stream 360. Sample 333 preferably is introduced (*e.g.*, from isolation loop 350) via valve 330
20 into another arm of Tee 359 connected to valve 330, so that a combined stream of sample 333 and transport medium 326 flows out of Tee 359 into analytical conduit 360. Preferably valve 330 is controlled by master controller 390.

[0056] Those of ordinary skill in the art will appreciate that other types and configurations of valves also can be used in embodiments. An alternative embodiment of a suitable valve is
25 described below and illustrated in Figures 15A-E.

[0057] Pump 340 in an embodiment is a syringe pump although other types of pumps, preferably a non-peristaltic pump such as a rotary pump with an injection valve, may be substituted for pump 340. Pump 340 draws a sample from a sample source 335 via sample line 334 through valve 330 and into the isolation loop 350. Pump 340 preferably is controlled by
30 master controller 390. An exemplary pump 340 can be obtained as an assembly with the Cavro XL 3000.

[0058] Isolation loop 350 prevents the entry of the sample into the cavity of the pump 340, thereby preventing the transference of one sample into another (*i.e.*, carrier-over). Isolation loop 350 allows for filling pump 340 with inert transport media while having the volume

capacity in loop 350 to hold a required quantity of sample without sample ever contaminating the syringe. In the single channel system illustrated in Figure 3, isolation loop 350 preferably has sufficient volume to hold at least the minimum volume of sample required to conduct one complete cycle of reactions. In an embodiment having multiple channels (such as the system
5 illustrated in Figs. 12-13), isolation loop 350 preferably has sufficient volume to hold at least the minimum volume of sample required to conduct one complete cycle of reactions for all channels, so that the syringe pump 340 can cycle through each channel and introduce a required quantity of sample into each channel without having to aspirate additional sample.

[0059] When exemplary system 300 is initialized, valve 330 is rotated to the waste port and the
10 syringe of pump 340 is driven to the full dispense position. The valve 330 then rotates to the transport medium position and pump 340 draws transport medium 326 from reservoir 325 via line 336 through a port of valve 330 and into pump 340 and isolation loop 350. Valve 330 is again rotated to the waste position and transport medium is expelled through waste line 332 until all air is removed from isolation loop 350. The pump is mounted vertically to ensure any
15 air is displaced prior to liquids, and system 300 is ready to operate.

[0060] When priming a sample, valve 330 is rotated to receive sample 333 via sample line 334 and the syringe in pump 340 is driven to aspirate the appropriate volume of sample 333 to fill the dead volume of the sample tubing 334 plus a predetermined excess. Valve 330 is rotated to the waste port and the syringe is driven to full dispense position to expel the excess sample.

20 Valve 330 then rotates back to the sample position and pump 340 pulls a volume of sample 333 into isolation loop 350. Valve 330 rotates to an analysis stream position where pump 340 dispenses the appropriate volume of sample 333 into Tee 359 where it is injected into the transport medium flowing therethrough from flow side conduit 311 and into analytical stream 360. After injection, valve 330 returns to the waste port where any excess sample and a portion
25 of the transport medium are expelled to waste.

[0061] As further shown in Figure 3, the arrangement of system 300 permits the isolation loop 350 to be flushed or rinsed between samples. When the pump 340 is filled with the transport medium from reservoir 326, the isolation loop 350 is flushed by the transport medium flow from the pump 340 when the valve 330 is selected to direct the transport medium flow to the
30 waste disposal line 332. By appropriately cycling pump 340 and the position of the multi-port valve 330, sample 333 or transport medium 326 can be pulled from the sample reservoir 335 or transport medium reservoir 325, respectively, and either introduced into analytical stream 360 or sent to the waste disposal line 332.

[0062] In an alternative embodiment, one or more sensors (unnumbered) may be positioned within the waste disposal line 332 to sense the presence (or lack thereof) of fluid therein, and thus minimize the wasteful consumption of sample due to the overloading of the waste disposal line 1250. Preferably such sensors include a conductivity sensor, however, other types of sensors may be used including, but not limited to, optical sensors, capacitance sensors, or pressure sensors. An autosampler probe (unnumbered), well known to those of skill in the art, may be employed in conjunction with the sample line 334 to automate and speed up the analysis of multiple samples. .

[0063] Exemplary system 300 comprises one or more reagent inlets, preferably four reagent inlets 363, 369, 375, 381, positioned along the length of analytical stream 360 and one or more mixing loops/volumes 366, 372, 378, 384. One or more reagents are introduced into analytical stream 360 at the proper time, place, and flow rate through reagent inlets 363, 369, 375, 381 to react with sample 331 and each other. The flow rate of transport medium 326 in flow side conduit 311 is adjusted inversely in relation to the added flow of the sample and the reagents into analytical stream 360 to maintain a constant or substantially constant flow rate. Although exemplary system 300 illustrates sample being introduced into analytical stream 360 upstream of reagents, it should be understood that in an alternative embodiment one or more reagents can be introduced into analytical stream prior to the introduction therein of any sample.

[0064] System 300 includes mixing loops/volumes 366, 372, 378, 384 as reaction devices to enable multiple different reaction sequences. In an embodiment the user can configure one or more of the mixing loops/volumes 366, 372, 378, 384 into any desired reaction device by substituting piping or tubing having any desired configuration, including length (for example, from fractions of an inch to several meters), bore (preferably in a range from micron sizes to multiple millimeters), shape (for example, straight, serpentine, or undulated), and material (*e.g.*, teflon or polymers, quartz or other glassy type materials, or metallic tubing), as called for by the reactions anticipated to occur within the piping or tubing. Exemplary reaction devices include analytical loops, delay loops, heated or cooled zones, catalytic zones or other reaction support devices.

[0065] System 300 provides means to introduce one or more reagents in analytical stream 360 and to control the timing and amount of introduction of reagents. System 300 as shown in Figure 3 includes injectors 364, 370, 376 and 382 to introduce reagents through inlets 363, 369, 375, 381 into analytical stream 360. Injectors 364, 370, 376 and 382 in Figure 3 are actuated via injector motor drivers 362, 368, 374, and 382. Injector motor drivers 362, 368, 374, and 382 are controlled by Master Controller 390. Figure 3 also shows reagent reservoirs

361, 367, 373, and 379 coupled to injectors 364, 370, 376 and 382. A preferred injector and injector motor is the Variable volume pump LPVX0502150B available from Lee Company. Those of ordinary skill in the art will recognize that other means can be used to add or introduce reagents to analytical stream 360, including, for example, miniature solenoid pump
5 LPLA1210550L available from Lee Company.

[0066] Master controller 390 in exemplary system 300 controls pump 340, valve 330, injector motor drivers 362, 368, 374 and 380 and, via FFC 310, the flow rate of the transport medium in analytical streams 311 and 360 as described below in connection with Figures 5-9. In an embodiment, master controller 390 is implemented on a computer, such as a personal computer
10 or workstation, comprising at least a CPU, input/output ports and means for controlling same such as a USART, memory, including RAM, and persistent storage for storing operating instructions and data. Master controller 390 includes software, code and instructions operative to implement the control functions and methods described herein in a manner familiar to those of ordinary skill in the art. Preferably master controller 390 also includes input devices (such
15 as a mouse and a keyboard) and output devices (such as a monitor) and user interface software to enable user configuration and control of different components and parameters of system 300 and monitoring and display of reservoir levels of transport medium 326, sample 331 and reagents in reagent reservoirs 361, 367, 373 and 379, and monitoring and display of the operation and status of the different components of system 300, including pump 340, valve
20 330, FFC 310, injectors and injector motors 362, 364, 368, 370, 374, 376, 380, 382, and detector 399. In an embodiment, FFC 310 is separate and not integrated with master controller 390. In an alternative embodiment FFC 310 is integrated with master controller 390. For example, the software instructions implementing the control processes performed by controller 420 of FFC 310 can be implemented on master controller 390, and/or controller 420
25 of FFC 310 may share hardware resources such as CPU, USART or other I/O control, system clock power supply, data or control bus, or RAM.

[0067] Master controller 390 preferably includes control software to control valve 330, the injection devices, *i.e.*, the reagent injector motors 362, 368, 374, 380 and pump 340, and FFC 310. The timing of introduction of reagents or sample can be controlled by master controller
30 390 based on elapsed time. Suppose, for example, it is desired to control injector 382 to introduce a reagent through inlet 381 into analytical stream 360 to react with sample 331. Because the flow rate of analytical stream 360 is constant or substantially constant and the relevant distance (e.g., between the point wherein sample 331 is introduced into analytical stream 360 and 381) is known, the elapsed time when sample 331 will flow by inlet 381 can be

determined and the control software can initiate injector motor 380 at the elapsed time. Alternatively, the timing of introduction of reagent can be determined based on detection of sample or another reaction product in analytical stream 360. In an embodiment, a conductivity sensor can be employed to detect the presence of sample by measuring the conductivity of analytical stream 360 around inlet 381, so that when the conductivity sensor detects a change in conductivity indicating presence of sample, it can trigger injection motor 380 or, preferably, set a flag to trigger injection motor 380 during the next system timer interrupt. It is to be understood that this discussion focusing on injector 382, inlet 381 and injection motor 380 is explanatory and the same principles apply to the other injectors in system 300.

[0068] In an embodiment the injection rates and volumes for each injection device are preset to a constant value. When the control software encounters an injection event at injector 382 during servicing of a system timer interrupt, it will signal injector motor 380 to introduce a quantity of reagent corresponding to the preset constant value for the injection rate and volume and the system timer frequency. At the same time, preferably during the same system timer interrupt service routine, the control software will signal FFC 310, via control line 314, to reduce the flow rate of transport medium 326 in flow-side conduit 311 by an amount corresponding to the volume of reagent introduced into analytical stream 360 by injector 382.

[0069] In an embodiment, the control software for master controller 390 can employ different injection rates and volumes for each injection device. Preferably the control software will maintain for each injection device a queue containing sequentially-accessed values corresponding to a desired injection rate and volume for each system timer cycle, and these values can be preset or dynamically controlled via master controller software. Preferably a separate queue is used for each sample and reagent injector to allow the controller 390 to compensate for overlapping injections. In an embodiment, pump 340 is adapted to supply sample to multiple channels, i.e., multiple parallel analytical streams, and in that embodiment the control software preferably maintains a separate sample injector queue for each channel.

[0070] System 300 also includes a detector 399. Exemplary detectors 399 are an oscilloscope, a photometric detector, a spectrophotometer, an electrochemical detector, and any other form of detector known to those of skill in the art suitable for use in analysis, quantification and small-scale chemical synthesis.

[0071] One or more reaction sequences, chemistries or processes may be performed in analytical stream 360 to convert the sample into a reaction product (i.e., analyte) that permits quantification and characterization by detector 399. For example, electrochemical cells, ion exchange, oxidation or reduction chemistries, ultraviolet sources, heat sources, active metal

surfaces, catalytic materials, phase separation elements, and digestions may be employed to produce the desired reaction product for quantification and characterization by detector 399. Furthermore, the analytical stream 360 may be configured to have one or more samples present at any given time in a serial arrangement (not shown) along the length of the analytical stream 360. After analytical stream 360 has been analyzed at the detector 399 of system 300, the contents of analytical stream 360 are expelled to waste.

[0072] In an alternative embodiment, instead of dispensing the contents of analytical stream 360 to waste, the contents of analytical stream 360 can be recycled to undergo another cycle of reaction processes. This alternative embodiment includes a recycling conduit (unnumbered) with one end connected to a recycling valve (unnumbered) and the other end connected to analytical stream 360 via valve 330 or an injector 364, 370, 376, 382. The recycling valve preferably is connected to analytical stream between mixing volume 384 and detector 399. Preferably master controller 390 controls the recycling valve to recycle the contents of analytical stream 360 and to send the recycled contents of analytical stream 360 to detector 399 after the desired number of cycles.

[0073] Figures 5 through 9 illustrate different stages of exemplary control algorithms implemented by FCC 310 and Master Controller 390 in connection with the operation of system 300 utilizing 4 reagents.

[0074] Figure 5 provides a timing diagram 500 showing flow rates at time T_2 874. Depicted are flow rates 825 for transport medium 820, 815 for Total Flow 810, and 835 for Sample 830. When the system is up to the required flow and stable, sample 830 is injected into the flow stream at T_2 874, as shown by the increase in flow rate 835 of Sample 830 during a time interval 510. During the injection of sample 830, FCC 310 adjusts the flow rate of transport medium 820 to maintain the Total Flow at the target total flow rate 809. When the sample 830 is injected at T_2 874, $F_{inj\ 1}$ will go from 0 $\mu\text{L}/\text{minute}$ to some number less than the target total flow rate 809. FCC 310 then will reduce the flow rate 825 of transport medium 820 to a flow rate equal to $F_{total} - F_{inj\ 1}$. When the injector ceases to inject Sample 830, i.e. when $F_{inj\ 1}$ is taken down to 0 $\mu\text{L}/\text{minute}$ at the end of interval 510, FCC 310 increases the flow rate 825 of transport medium 820 to bring Total Flow 815 back to the target total flow rate 809.

[0075] Figure 6 provides a timing diagram 600 that also shows flow rates at time T_3 876 after injection of Reagent 1 (840). Depicted are flow rates 825 for transport medium 820, 815 for Total Flow 810, 835 for Sample 830, and 845 for Reagent 1 (840). With the sample in the stream, the first reagent injector, injector 1 (364) makes an addition of Reagent 1 (840) to the

flow stream at T_3 876 during a time interval 620. During the injection of the reagent 1 (840), FCC 310 adjusts the flow rate 825 of transport medium 820 to maintain Total Flow 815 at the target total flow rate 809. Timing this injection can be accomplished as a time function or through the use of a sensor (conductivity or other) can be placed in front of the injector to trigger the event. During the injection of sample 830, FCC 310 adjusts the flow rate 825 of transport medium 820 to maintain the Total Flow at the target total flow rate 809. In other words, $F_{TM} = F_{total} - F_{inj\ 2}$ during time interval 620.

[0076] Figure 7 provides a timing diagram 700 that also shows flow rates at times T_4 878, T_5 880 and T_6 882 after injection of Reagent 2 (850), Reagent 3 (860), and Reagent 5 (870), respectively. With a quantity 802 of sample 830 and reagent 1 (840) in the stream, the second reagent injector, injector 2 (370) makes an addition of Reagent 2 (850) to the flow stream at T_4 878 during a time interval 720. At time T_5 880, Reagent injector 3 (376) injects Reagent 3 860 into the stream during interval 730, and at time T_6 882, Reagent injector 4 (382) injects Reagent 4 (870) into the stream during interval 740. During the injection of each reagent FCC 310 adjusts the flow rate of transport medium 820 to maintain the Total Flow 810 at the target total flow rate 809. During interval 720, while Reagent 2 (850) is being injected at flow rate $F_{inj\ 2}$, FCC 310 adjusts F_{TM} so that it equals $F_{total} - F_{inj\ 2}$. Similarly, during interval 730, FCC 310 adjusts F_{TM} so that it equals $F_{total} - F_{inj\ 3}$, and during interval 740, FCC 310 adjusts F_{TM} so that it equals $F_{total} - F_{inj\ 4}$. Timing of these injections can again be accomplished as a time function or a sensor (conductivity or other) can be placed in front of the injector to trigger the event.

[0077] In a simple sequence a sample and all of its associated injections are completed prior to additional sample processing. When multiple samples are processed in a simple sequence, FCC 310 will make adjustments for each injection, preferably under the control of master controller 390, as illustrated in Figure 8. Figure 8 shows the serial processing of a first quantity 802 of sample 830, as also depicted in Figure 7, and a second quantity 804 of sample 830, which is also processed by system 300 as depicted in Figure 7. Second quantity 804 of sample 830 is injected into the flow stream at time T_2 884, at which time FCC 310 reduces flow rate 825 of transport medium 820 by an amount equal to the flow rate 835 of sample 830 so that the total flow rate 815 remains constant at the target total flow rate 809. When a quantity of Reagent 1 (840) is injected at time T_3 886 at flow rate 845, FCC 310 reduces flow rate 825 of transport medium 820 by an amount equal to the flow rate 845 of Reagent 1 (840) so that the total flow rate 815 remains constant at the target total flow rate 809. Similarly for quantities of Reagent 2 (850), Reagent 3 (860), and Reagent 4 (870) injected at times T_4 888,

T_5 890 and T_6 892, in each case FFC 310 reduces flow rate 825 of transport medium 820 by an amount equal to the flow rate of the injected reagent (855, 865, 875) to maintain the total flow rate 815 at the target total flow rate 809.

[0078] In an embodiment in which multiple samples are processed in an oversampling method (i.e., the first sample is still being processed when the second is injected), FCC 310 (preferably as controlled by master controller 390) will make adjustments for multiple injectors acting simultaneously as illustrated in Figure 9. Figure 9 provides a timing diagram 900 which depicts Total Flow rate 915 and flow rates 925 for transport medium 920, 935 for Sample 930, 945 for Reagent 1 (940), 955 for Reagent 2 (950), 965 for Reagent 3 (960) and 975 for Reagent 4 (970). When system 300 is initiated at time T_1 972, FFC 310 brings flow rate 925 of transport medium 920 up to the target total flow rate 909. With no other flow sources, total flow 915 equals the flow rate 925 of transport medium 920. At time T_2 973, a first quantity 931 of sample 930 is injected, and FFC 310 reduces F_{TM} 925 by an amount equal to sample flow rate 935 during the interval while sample 931 is being injected to maintain F_{total} 915 at the target total flow rate 909. At time T_3 974, a first quantity 941 of Reagent 1 (940) is injected, and FFC 310 reduces F_{TM} 925 by an amount equal to Reagent 1 flow rate 945 during the interval while the Reagent 1 (941) is being injected to maintain F_{total} 915 at the target total flow rate 909.

[0079] Beginning with time T_4 976, timing diagram 900 shows what happens when two or more samples or reagents are simultaneously added to the system. At time T_2 975, a second quantity 932 of sample 930 is added during an interval 936, and FFC 310 reduces F_{TM} 925 by an amount equal to sample flow rate 935 during interval 936 while the sample (932) is being added to maintain F_{total} 915 at the target total flow rate 909. Beginning at time T_4 976 during interval 936, a first quantity 951 of Reagent 2 (950). FFC 310 reduces F_{TM} 925 by an amount equal to the sum of sample flow rate 935 and Reagent 2 flow rate 955 during the remainder of interval 936 to maintain F_{total} 915 at the target total flow rate 909. At the end of interval 936, FFC brings sample flow rate 935 and Reagent 2 flow rate 955 back to 0 and transport medium flow rate 925 is restored to the target total flow rate 909.

[0080] At time T_3 977, a second quantity 942 of Reagent 1 (940) is added, and FFC 310 reduces F_{TM} 925 by an amount equal to Reagent 1 flow rate 945 to maintain F_{total} 915 at the target total flow rate 909. At time T_5 978, FFC 310 simultaneously stops adding Reagent 1 (940), i.e., brings Reagent 1 flow rate 945 to 0, and begins adding a first quantity 961 of Reagent 3 (960). FFC 310 reduces F_{TM} 925 by an amount equal to Reagent 3 flow rate 965 to maintain F_{total} 915 at the target total flow rate 909. In the example shown in Fig. 9, the flow

rate 965 for Reagent 3 at time T_5 978 is the same as Reagent 1 flow rate 945 at time T_3 977, so there is no net change in the transport medium flow rate 925.

[0081] At time T_2 980 in Figure 9, a third quantity 933 of sample 930 is added during an interval 937, and FFC 310 reduces F_{TM} 925 by an amount equal to sample flow rate 935 during interval 937 while the sample (933) is being added to maintain F_{total} 915 at the target total flow rate 909. Beginning at time T_4 981 during interval 936, a second quantity 952 of Reagent 2 (950) is added. FFC 310 reduces F_{TM} 925 by an amount equal to the sum of sample flow rate 935 and Reagent 2 flow rate 955 during the remainder of interval 936 to maintain F_{total} 915 at the target total flow rate 909. At the end of interval 936, FFC 310 brings sample flow rate 935 and Reagent 2 flow rate 955 back to 0 and transport medium flow rate 925 is restored to the target total flow rate 909.

[0082] At time T_3 982, a third quantity 943 of sample Reagent 1 (940) is added, and FFC 310 reduces F_{TM} 925 by an amount equal to Reagent 1 flow rate 945 to maintain F_{total} 915 at the target total flow rate 909. Beginning at time T_6 983, a first quantity 971 of Reagent 4 (970) is added, and FFC 310 further reduces F_{TM} 925 by an amount equal to the sum of Reagent 1 flow rate 945 and Reagent 4 flow rate 975 to maintain F_{total} 915 at the target total flow rate 909. At time T_5 984, FFC 310 brings Reagent 1 flow rate 945 back to 0 and also begins adding Reagent 3 (960). Beginning at time T_5 984, FFC 310 maintains F_{TM} 925 at a flow rate equal to F_{target} 909 minus the sum of Reagent 3 flow rate 965 and Reagent 4 flow rate 975, thereby maintaining F_{total} 915 at the target total flow rate 909. At time 985, FFC 310 brings Reagent 4 flow rate 975 back to 0 and increases F_{TM} 925 so that it equals F_{target} 909 minus Reagent 3 flow rate 965, and FFC 310 maintains this flow rate until time T_2 986 when it brings Reagent 3 flow rate 965 back to 0. Also at time T_2 986, FFC 310 adds a fourth quantity 934 of sample 930 to the stream. At time T_2 986, FFC 310 increases transport medium flow rate 925, to compensate for Reagent 3 flow rate 965 going to 0, and decreases transport medium flow rate 925, to compensate for the increase in sample flow rate 935, with the net effect being that FFC 310 reduces F_{TM} 925 so that it equals F_{target} 909 minus sample flow rate 935. This flow rate is maintained time T_4 987, when FFC 310 begins adding a third quantity 953 of Reagent 2 (950) and decreases F_{TM} by the amount of Reagent 2 flow rate 955, so that F_{TM} equals target total flow rate 909 minus the sum of sample flow rate 935 and Reagent 2 flow rate 955. At time 988 FFC 310 takes sample flow rate 935 and Reagent 2 flow rate 955 to 0 and restores transport medium flow rate 925 to the target total flow rate 909.

[0083] Figures 10 through 14 illustrate an embodiment of a system and method of regulating the flow of a fluidic device comprising one or more channels of analysis. System 1010 as

depicted in Figure 10 comprises four modules: a pumping system and flow control module 1020, a sample introduction module 1040, a sample reaction module 1060, and a sample detection module 1080. The pumping system and flow control module 1020 employs a fluidic pump 1114 (shown in Figure 11) that imparts the motive force to a transport medium flowing via the analytical streams 101030a-f of the system 1010. One or more programmable fluidic flow controllers 1090a-f are employed in conjunction with the system 1010 to control the flow of the transport medium within each of the analytical streams 1030a-f. The fluidic flow controllers 1090a-f control the flow rate of the transport medium through the analytical streams 1030a-f in order to maintain a constant flow at the detectors 1082a-f (Figure 15) within the sample detection module 1080 even while samples are injected into the analytical streams 1030a-f within the sample introduction module 1040 (Figure 12) and reagents are injected into the analytical streams 1030a-f within the sample reaction module 1060. A constant flow at the detectors 1082a-f (Figure 14) does not necessarily imply that a constant flow is maintained at all points along the analytical streams 1030a-f. Typically, the flow rate of the analytical streams 1030a-f is not constant, but is controlled to properly sequence the addition of the sample and one or more reaction reagents and to permit one or more reaction processes prior to analysis by the detectors 1082a-f (Figure 14).

[0084] The system 1010 preferably is not a series of independent modules 1020, 1040, 1060, 1080, but rather is a system comprised of elements that permit improved quantification, throughput (samples per unit time), up time (lower downtime required for maintenance, re-alignment, and calibration), greater flexibility in set up, lower reagent use, limited generation of waste and greater reliability. This system 1010 is described and illustrated in modular form only for the ease of disclosure. While subsystems could be made in a modular form, the system 1010 of a preferred implementation has elements that, while performing varying functions, are closely interdependent and holistically controlled by one or more programmable fluidic flow controllers 1090a-f.

[0085] As illustrated in Figure 11, the pumping system and flow control module 1020 preferably comprises a fluidic pump 1114, a filter element 1132, a manifold 1116, a pressure sensor 1122, a back pressure regulator 1118, and a reservoir 1112. The nature and operation of fluidic pump 1114, filter element 1132, pressure sensor 1122, back pressure regulator 1128 and reservoir 1112 of transport medium are described in more detail above as, respectively, pump 327, filter 329, sensor 321, back pressure regulator 323 and reservoir 325 of transport medium 326 of constant pressure system 320 of exemplary system 300 illustrated in Fig. 3. The fluidic pump 1114 draws a transport medium from reservoir 1112 and directs it to the one or more

transport streams 1030a-f through manifold 1116. Fluidic pump 14 preferably maintains a constant flow rate across a filter element 1132 that is positioned between the pump 1114 and the manifold 1116.

[0086] As shown in Figure 11, the back pressure regulator 1118 is disposed in a side stream positioned downstream of the fluidic pump 1114 between the filter element 1132 and the manifold 1116. The back pressure regulator 1118 maintains the flow of the transport medium from the fluidic pump 1114 at a constant pressure. Preferably, the back pressure regulator 1118 maintains the pressure at 20 psig such that the pressure to the manifold 1116 and each of the analytical streams 1030a-f is also maintained at 20 psig. The arrangement of the pumping system and flow control module 1020, as shown in Figure 11, provides a restrictive control on the pressure and flow of the transport medium to the manifold 1116. The back pressure regulator 1118 operates by permitting the flow of transport medium therethrough at a varying flow rate to maintain the back pressure at a desired level. Any transport medium flowing through the back pressure regulator 1118 is returned to the fluid reservoir 1112 supplying transport medium to the pumping system and flow control module 1020. The flow of transport medium across the back pressure regulator 1118 will be orders of magnitude higher than the total flow to and through the individual analytical streams 1030a-f. Therefore, the flow of transport medium to the analytical streams 1030a-f via manifold 1116 will have little to no effect on the pressure maintained by the flow of transport medium through the back pressure regulator 1118. The output signal from pressure sensor 1122, positioned between the filter element 1132 and the back pressure regulator 1118, is used to control the flow rate of the fluidic pump 1114 either manually or through automatic feedback control. However, the primary purpose of pressure sensor 1122 is to determine the supply side pressure. As is well known in the art, the differential pressure between the supply side pressure and the individual analytical stream pressures may be used to determine the individual analytical stream flows.

[0087] As further illustrated in Figure 11, manifold 1116 employs six flow elements 1128a-f (in an embodiment, capillary tubings) with differential pressure sensing that are used to transport the analytical streams 1030a-f comprising the sample/analyte, transport medium, and reagents. Additional flow elements (not shown) may be coupled to the manifold 1116 for the analysis of additional analytical streams (not shown). Likewise, fewer than six flow elements (not shown) may be coupled to the manifold 1116 for the analysis of fewer analytical streams (not shown). In a preferred implementation, each of the flow elements 1128a-f are sized for a desired flow rate. A variable sized orifice (VSO) valve assembly 1126a-f is also preferably disposed within each of the flow elements 1128a-f to further control the absolute flow of

transport medium through the flow elements 1128a-f (i.e., the analytical streams 1030a-f). VSO valve 1126a-f can comprise a voltage-controlled orifice. Each analytical stream 1030a-f has a programmable fluidic flow controller 1090a-f, which controls the flow rate of transport medium through flow elements 1128a-f as well as the time and spatial addition of sample and reagents to the analytical streams 1030a-f.

[0088] Within pumping system and flow control module 1020, the fluidic flow controllers 1090a-f are employed to regulate the flow transport medium through the flow elements 1128a-f of each analytical stream 1030a-f by controlling the VSO valve 1126a-f of each flow element 1128a-f such that a constant flow is delivered to detectors 1082a-f (Figure 14). The fluidic flow controllers 1090a-f regulate the size of the orifice in the VSO valves 1126a-f based upon flow rate feedback data received from flow sensing elements 1124a-f (e.g., pressure sensors/meters, flow sensors/meters, or any other sensing element) disposed within each of the flow elements 1128a-f downstream of the VSO valves 1126a-f. Alternatively, a capillary restriction 1127a-f may be positioned within each of the flow elements 1128a-f and sized to control the flow of each of the analytical streams 1030a-f. The capillary restrictions 1127a-f may be used either alone or in conjunction with the VSO valves 1126a-f. Because the pumping system and flow control module 1020 preferably utilizes a constant pressure pump 1114, a shut down of the pump 1114 is required to fully shut down the module 1020. Therefore, fluidic flow controllers 1090a-f must also prevent the back flow of sample and/or reagents from the sample reaction module 1060 when transport medium is not being pumped by pump 1114. Back flow of sample and/or reagents is most likely to occur either during sample introduction or addition of reagents into the analytical streams 1030a-f. Back flow of sample and/or reagents into the transport medium reservoir 1112 may be prevented by using fluidic flow controllers 1090a-f to fully close the VSO valves 1126a-f.

[0089] As illustrated in Figure 12, the sample introduction module 1040 preferably comprises a syringe pump 1246, a three-way valve 1252, an isolation loop 1245, a sample prime pump 1255 and one or more multi-port valves 1242. The purpose of the sample introduction module 1040 is to acquire a sample, inject a programmed amount of the sample into one or more analytical streams 1030a-f at the appropriate time and at the appropriate delivery rate, and to purge/rinse the isolation loop 1245 in preparation for the next sample injection. The syringe pump 1246 draws a sample from a sample source 1248 through the sample line 1244, the multi-port valve 1242, and into the isolation loop 1245. The isolation loop 1245 prevents the entry of the sample into the cavity of the syringe pump 1246, thereby preventing the transference of one sample into another (i.e., carrier-over). The fluidic flow controller 1090a-f

associated with each analytical stream 1030a-f controls the operation of the syringe pump 1246, the three-way valve 1252 and the rotary multi-port valve 1242 to inject the aspirated sample into the proper analytical stream 1030a-f at the appropriate time and delivery rate. The syringe pump 1246 may also draw transport medium from reservoir 1112 through the three-way valve 1252 for delivery to each analytical stream 1030a-f via the isolation loop 1245 and the multi-port valve 1242. As the analytical streams 1030a-f are each selected for sample injection and analysis, the fluidic flow controller 1090a-f associated with the selected analytical stream 1030a-f also controls its VSO valve 1126a-f to increase or decrease the flow of transport medium through the selected flow element 1128a-f (i.e., analytical stream 1030a-f) (Figure 11) such that, with the injection of the sample, a constant flow and/or pressure is achieved at the detector 1082a-f (Figure 5). However, the pressure at which the sample is introduced into the analytical streams 1030a-f preferably remains constant during the injection process in order to facilitate the fluidic flow controllers 1090a-f in maintaining a constant flow of the analytical streams 1030a-f at the detectors 1082a-f (Figure 14). The fluidic flow controllers 1090a-f use one or more microcontrollers and/or microprocessors to synchronize in time and/or volumetric space the introduction of sample into the analytical streams/channels 1030a-f. Exemplary fluidic flow controllers 1090a-f include controller 420 of FFC 310 and master controller 390 of system 300, as illustrated in, and described in connection with, Figures 3-4. In an embodiment, fluidic flow controllers 1090a-f are all integrated in a single controller; in an alternative embodiment, each analytical stream 1030a-f has a dedicated fluid flow controller 1090a-f.

[0090] As further shown in Figure 12, the arrangement of the sample introduction module 1040 permits the isolation loop 1245 to be flushed or rinsed between samples. When the syringe pump 1246 is filled with the transport medium from reservoir 1112, the isolation loop 1245 is flushed by the transport medium flow from the syringe pump 1246 when the multi-port valve 1242 is selected to direct the transport medium flow to the waste disposal line 1250. By appropriately cycling the three way valve 1252, the syringe pump 1246, and the position of the multi-port valve 1242, sample or transport medium can be pulled from the sample source 1248 or the reservoir 1112, respectively, and either introduced into a specific analytical stream 1030a-f or sent to the waste disposal line 1250. Additionally, one or more sensors 1254 may be positioned within the waste disposal line 1250 to sense the presence (or lack thereof) of fluid therein, and thus minimize the wasteful consumption of sample due to the overloading of the waste disposal line 1250. In a preferred implementation of the invention, sensor 1254 is a conductivity sensor, however, other types of sensors may be used including, but not limited to,

optical sensors, capacitance sensors, or pressure sensors. An autosampler probe 1256, well known to those of skill in the art, may be employed in conjunction with the sample line 1244 of the sample introduction module 1040 to automate and speed up the analysis of multiple samples.

5 [0091] In another embodiment of the system, as shown in Figure 13, an eight-way valve 1341 is used in place of the multi-port valve 42 of Figure 3. The eight-way valve 1341 incorporates the three-way valve 1252 of Figure 12. The arrangement and operation of the sample introduction module 1340 is otherwise the same as shown and described with respect to the sample introduction module 1040 shown in Figure 12. An embodiment of an eight-way valve
10 1341 is discussed below.

[0092] In an embodiment, sample prime pump 1255 is preferably positioned within the waste disposal line 1250 to prime the sample line 1244 with sample from sample source 1248 so that no air or fluid contamination is aspirated into the isolation loop 1245 via the valve (1242 or 1341) during operation of the syringe pump 45 to draw sample.

15 [0093] While it is preferable that the introduction of sample into the analytical streams 1030a-f directs the flow of the analytical streams 1030a-f toward the sample reaction module 1060 and detection module 1080, the flow within the analytical stream/channel 1030a-f need not be single directional. For example, during sample injection, the flow within the analytical stream 1030a-f may briefly reverse to allow rapid injection of the sample into the analytical stream
20 1030a-f. However, the sample injection cannot overflow the volume of the flow element 1128a-f and flow back to the pumping system module 1020, which could result in some of the sample being transferred into the transport medium reservoir 1112 via backflow pressure regulator 1118. Nevertheless, the back-fill capability (i.e., limited reverse flow) permits rapid filling of the individual analytical stream or channel 1030a-f, and thereby permits the sample
25 introduction module 1040 to rapidly service multiple analytical channels 1030a-f so as to achieve a high analytical throughput.

[0094] For non-segmented flow, stipulating both a constant flow rate and flow in a single downstream direction requires the fluidic flow controller 1090a-f to introduce the sample via syringe pump 1246 at the proper time and flow rate so as to not “push” sample upstream within
30 the analytical streams/channels 1030a-f, yet quantitatively transfer the sample to a known volume of transport medium (i.e., a known dilution of sample/analyte, ranging from no dilution to a system or operator determined value). The flow of the analytical streams 1030a-f need not be truly non-segmented and may alternatively consist of spatial regions of higher and lower concentrations of sample/analyte (i.e., known stepwise levels or continuous gradients of

sample/analyte). In contrast, segmented flow may be achieved by injecting the typically aqueous sample into the transport medium within the analytical stream 1030a-f, thereby creating a pocket or bolus of analyte sandwiched between the upstream and downstream transport medium. As previously described, the transport medium could be highly purified water (i.e., de-ionized water), a gas (e.g., air, nitrogen, helium, etc.), a hydrophobic media, such as perfluorinated polyether (PFPE), multiply-alkylated cyclopentanes, or any other highly hydrophobic fluid, or any other substance that can create a phase boundary between the analytical sample and the transport medium. Alternatively, segmented flow can be created through the classical method of injecting slugs of air into the transport medium of the analytical streams 1030a-f prior to the point of sample injection within the sample introduction module 1060.

[0095] As illustrated in Figure 14, the sample reaction module 1060 of each analytical stream 1030a-f preferably comprises one or more reagent inlets 1462a-f, 1464a-f, 1466a-f, and one or more mixing loops/volumes 1468, 1470, 1472. In the sample reaction module 1060, reagents are injected at the proper time, place, and flow rate through inlets 1462a-f, 1464a-f, 1466a-f positioned along the length of the analytical streams 1030a-f in order to provide constant flow to the detectors 1082a-f of the sample detection module 1080, which is also illustrated in Figure 14. The fluidic flow controllers 1090a-f adjust the transport medium flow inversely in relation to the added flow of the sample in the sample introduction module 1040 and the reagents in the sample reaction module 1060. One or more reaction sequences may be performed on each of analytical streams 1030a-f to convert the sample into a reaction product (i.e., analyte) that permits quantification and characterization by the detectors 1082a-f. Thus, the sample reaction module 1060 preferably has multiple mixing loops/volumes 1468a-f, 1470a-f, 1472a-f to permit multiple reaction sequences. As illustrated in connection with system 300, the user can use and substitute different configurations of mixing loops/volumes 1468a-f, 1470a-f, 1472a-f. One or more reaction chemistries/processes may also be performed on each of the analytical streams 1030a-f. For example, electrochemical cells, ion exchange, oxidation or reduction chemistries, ultraviolet sources, heat sources, active metal surfaces, catalytic materials, phase separation elements, and digestions may be employed to produce the desired reaction product for quantification and characterization by the detectors 1082a-f. Furthermore, each analytical stream 1030a-f may be configured to have one or more samples present at any given time in a serial arrangement (not shown) along the length of the analytical stream 1030a-f. After each analytical stream 1030a-f has been analyzed at the detectors 1082a-f of sample detection module 1080, the analytical streams 1030a-f are sent to the waste

disposal line 1250. Alternatively, one or more of the analytical streams 1030a-f can be recycled to the same or a different channel for further reaction processes (path switching).

[0096] As generally shown in Figure 10, an embodiment of the system and method of the invention permits a more accurate quantification and/or characterization of the analytes of interest to be achieved. As previously disclosed, the use of a syringe pump 1246 (Figures 12 and 13) in conjunction with the fluidic flow controllers 1090a-f permits control of not only the volume of the sample injection into each analytical stream 1030a-f but also the precise timing of when the sample injection begins and the time period over which the sample injection occurs. When dynamically coupled with the pumping system and flow control module 1020 (Figure 11) and the sample reaction module 1060 (Figure 14), rapid sample injection techniques become possible along with the controlled dilution of the sample and the use of either segmented flow or non-segmented flow.

[0097] Additional techniques, such as auto dilution of sequential analyses, testing for reaction completion by adding excess reagents, determination of kinetic rate information (e.g., reaction/residence time in reactor as function of flow rate versus reaction response), and auto-optimization for method development, may each be employed individually or collectively with one or more implementations of the invention. For example, auto dilution of sequential analyses can occur by either increasing the flow rate of the transport medium or by injecting/introducing less sample into the transport medium of the analytical streams by employing a smaller sample volume. Furthermore, as previously disclosed, path switching may be employed to improve throughput by allowing a first portion of an analytical stream to proceed along a first reaction pathway (i.e., to be subjected to a specific set of reagents and reaction processes), and a second portion of the analytical stream (or its reaction product) to be routed into a parallel second reaction pathway and subjected to alternative reagents and reaction processes. Several analytical determinations may then be conducted using one or more detectors including, but not limited to, detection of analytes in the first and/or second portions of the analytical stream, followed by detection of analytes in the first reaction product, and finally, detection of analytes in the second reaction product.

[0098] A conventional embodiment of an 8-port rotary valve comprises eight radially-arranged input/output ports (labeled A through H) and a center port (S or Common) and is configured in a way that allows it to be connected to any one of the eight ports independently. The valve is typically connected to an electrical actuator, for example a stepper motor, which is capable of turning the rotor plate, and through control electronics this actuator is commanded to rotate to the desired port. A motive force provider, for example a syringe pump, typically is connected

to the center port, and the syringe pump can aspirate or expel through whatever input/output port is connected to the center port by the actuator.

[0099] A conventional 8-port valve can be adapted for use in a method and system for regulating flow in a fluidic device and, in particular, for use as valve 1341 in the embodiment shown Figure 13. Such an embodiment preferably includes two primary differences from a conventional embodiment of an 8-port valve. First, one port, "H" is relocated to a second connection pattern on a different outer radius from ports A-G, and an additional port ("DI") is disposed on the same outer radius as port H and connected to a source of a transport medium such as DI Water. These ports (H and DI) can only be connected when the valve is rotated to the "H" position, and in any other position both port "H" and the DI port are blocked. When the valve is rotated to the "H" port the common is blocked off and aspirating the syringe pump will draw DI water to the front of the syringe bypassing the Isolation loop. Second, the other seven ports are modified to have a "Tee" built in. Each of the other ports (the "flow through ports") has an input conduit and an output conduit. Port C, for example, will have an input conduit C_{in} and an output conduit C_{out} . When the rotary valve points to any position away from port C (i.e., A-B, D-H), there is no path to the common port and transport medium flows through C_{in} and out C_{out} with no change or addition. When the rotary valve points to port C, however, there is an open "Tee" between the center port and C_{in} and C_{out} , so that when the syringe pump dispenses sample into the center port, the transport medium from C_{in} and the sample from the syringe pump both flow out through C_{out} . This embodiment of a modified valve can support six channels of analysis.

[00100] Figures 15A-E illustrate valve 1500, an exemplary embodiment of the modified valve described above. Although the exemplary embodiment shown Figures 15A-E supports only three different channels of analysis, those of ordinary skill in the art will appreciate that the structure disclosed herein can be adapted to support six channels of analysis and to serve the function of valve 1341 in Figure 13. Fig. 15A illustrates a side view of valve 1500 showing valve body 1502, input conduit portals A1 (1504) and B1 (1505) and conduit portals H (1516) and S2 (1503).

[00101] Figure 15B is an exploded view of the components of valve 1500 including valve top 1501, and valve body 1502 comprising conduit portals S2 (1503), A1 (1504), B1 (1505), and C1 (1506). Stator 1508 is fixed in place with dowel pin means 1536 and 1507 and is drilled with, preferably, ten penetrations needed to interface with rotor 1509. The penetrations are organized as a center port with two hole patterns at different radii from the center. The inner radius has seven penetrations every 22.5° starting with the penetration

corresponding to the A port. The outer radius has penetrations for the H port and the DI port. The penetrations correspond to conduits between center port S1 (the center port) (1520), sweep sweep ports A-C, and standard ports D-F (on the inner circle). There is no penetration on the inner circle for the H port (1516). When the H port (1516) is selected there is no flow through
5 the center port; however, the outer circle connects the H port (1516) to a source of transport medium such as DI (not shown) through the DI port. Seal washers 1426 prevent leakage as fluid flows through the penetrations. Stator 1508 is coupled to rotor 1509 which embraces thrust bearing 1510. Valve blade 1511 is disposed within thrust bearing 1510 and sleeve washer 1512, which surrounds spring 1513 supported by valve cap 1514. The entire assembly
10 is joined together by screws 1524, screw bodies 1525, and screw knurls (unnumbered). When mounted to an actuator chassis (not shown) the valve blade 1511 interfaces with the actuator (not shown) to provide positioning of the valve.

[00102] Fig. 15C illustrates valve top 1501 comprising output conduit portals A (1517), B (1518), C (1519), and port S1 (1520). As described above, for the sweep ports A, B and C in
15 valve 1500, when the rotary is not pointing to that port, transport medium flows through from the input conduit portals A1, B1, and C1 (1504, 1505, 1506) and out the output conduit ports A, B and C (1517, 1518, and 1519).

[00103] Fig. 15D illustrates the cross-section view along an axis shown in Fig. 15C. Fig. 15D shows an exemplary syringe pump 1529 connected to syringe port 1530, an
20 exemplary isolation loop 1528 connected to port S1 (1520), and a bypass conduit 1527 connecting isolation loop 1528 and port S2 (1503). In an embodiment bypass conduit 1527 is part of isolation loop 1528. Also shown are internal conduits 1521, 1522, and 1523. Internal conduit 1521 provides fluid communication between center port S1 (1520) and syringe port 1530; internal conduit 1522 provides fluid communication between internal conduit 1521
25 through a penetration in the outer radius of stator 1508 to rotor 1509. Internal conduit 1523 provides fluid communication between port S2 (1503) and the stator 1508 center penetration to rotor 1509. Fig. 15E shows cross-sectional view of valve 1500 along axis B-B in Fig. d and illustrates sweep ports A-C and penetrations corresponding to the penetrations in stator 1508.

[00104] Fig. 15D illustrates two modes of operation of valve 1500. When it is desired to
30 aspirate transport medium directly into syringe pump 1529 bypassing isolation loop 1528, the valve is turned to position H. In position H, there is an open conduit within the outer radius between port H, connected to a source of transport medium (not shown), and inner conduit 1522, and the center port in rotor 1509 is blocked. The syringe pump can then aspirate transport medium directly from internal conduit 1522.

[00105] When it is desired to inject the contents of injection loop 1528, for example sample, into an analysis stream, for example, the analysis stream connected to ports C (1519) and C1 (1506), the internal conduit 1521 is first filled with transport medium. The system is primed through a series of syringe actions. These actions are initiated with the valve at port G, the sample/waste position, the prime pump engaged, the syringe is moved to full dispense position. This eliminates any unknown content from the isolation loop. The prime pump is turned off and the valve is moved to the H port and the syringe 1529 moved to the fully aspirated position. This action aspirates transport media from reservoir 1112 to port H of valve 1500 through the rotor 1509 and a penetration in the outer circle of stator 1508 through internal conduits 1522 and 1521 in to the syringe. The syringe 1529 contents are then emptied by placing the valve 1500 at port G, the sample/waste position, engaging the prime pump, and moving the syringe to full dispense position. This eliminates any unknown content from the isolation loop and rinses the syringe. The prime pump is turned off, the valve 1500 is moved to the H port, and the syringe 1529 moved to the partially aspirated position and is ready to operate. After the system is primed, the rotary is turned to position C. In position C internal conduit 1522 is blocked but internal conduit 1523 is connected to flow sweep port C through the center port in stator 1508 and via rotor 1509. Applying syringe pump 1529 therefore expels transport medium from internal conduit 1521 into isolation loop 1528, which expels sample from isolation loop 1528 through conduit 1527, through port S2 (1503), through internal conduit 1523, and through stator 1508 into rotor 1509 and through to port C where it joins with transport medium flowing into input conduit portal C1 (1506) (C_{in}) and the stream containing transport medium and sample flows out through output conduit portal C (1519) (C_{out}).

[00106] In an embodiment the system utilizes a single port to both acquire a sample for analysis and to discharge waste. The valve 1500 utilizes port G as the sample/waste position, Sample is primed by engaging the prime pump, inserting the input tube into a sample vessel and either through a time interval or a sample sensing technique stopping the pump when the sample is primed. In this process any excess sample is discharged to waste. The syringe 1246 via the isolation loop 1245 and valve 1500 can now aspirate sample and inject the needed volumes into any or all of the system analytical streams. When all needed injections of a particular sample have been completed the input tube can be lifted from the sample vessel, either manually or through the actions of an autosampler, the valve 1500 is moved port G, the sample/waste position, the prime pump engaged, and the syringe is moved to full dispense position This eliminates any unwanted content from the isolation loop and valve as well as

provides an internal rinse with the transport media. Additional rinsing can be accomplished during this process by placing the input tube in a rinse agent. The prime pump is turned off when the waste/rinse cycle has been completed. After rinsing is completed the sample cycle can be repeated.

5 [00107] The Abstract of the disclosure is written solely for providing the United States Patent and Trademark Office and the public at large with a means by which to determine quickly from a cursory inspection the nature and gist of the technical disclosure, and it represents one preferred implementation and is not indicative of the nature of the invention as a whole.

10 [00108] While some implementations of the invention have been illustrated in detail, the invention is not limited to the implementations shown; modifications and adaptations of the above embodiment may occur to those skilled in the art. Such modifications and adaptations are in the spirit and scope of the invention as set forth herein.

CLAIMS

What is claimed is:

1. A system for regulating flow in a fluidic device, comprising:
one or more analytical streams comprising a transport medium and flowing through:
a pumping system and flow control module;
a sample introduction module;
a sample reaction module; and
a sample detection module.
2. The system of claim 1 wherein the pumping system and flow control module controls the flow of transport medium in the one or more analytical streams to maintain a constant flow at a detector comprised in the sample detection module.
3. The system of claim 1 wherein the pumping system and flow control module comprises at least one fluidic flow controller.
4. The system of claim 3 wherein the at least one fluidic flow controller comprises controls a variable-sized orifice for each of the one or more analytical streams.
5. The system of claim 4 wherein the pumping system and flow control module comprises a non-peristaltic pump that provides transport medium at a constant pressure to the variable sized orifice for each of the one or more analytical streams.
6. The system of claim 1 wherein the sample introduction module comprises a syringe pump.
7. The system of claim 6 wherein the sample introduction module further comprises an isolation loop.
8. The system of claim 1 wherein the sample reaction module comprises at least one reagent inlet in each of the one or more analytical streams.
9. The system of claim 1 wherein the sample reaction module further comprises a reaction device in a first analytical stream.
10. The system of claim 9 wherein the reaction device comprises an analyte produced by a reaction between a sample introduced by the sample introduction module into the first analytical stream and a reagent introduced by the sample reaction module into the first analytical stream.
11. The system of claim 10 wherein the analyte is detected by a detector comprised in the sample detection module.
12. The system of claim 11 wherein the analyte has a constant flow at the detector.
13. The system of claim 12 wherein the pumping system and flow control module maintains a constant flow rate of the analyte at the detector by controlling the flow of transport medium in the first analytical stream to compensate for the sample and the reagent introduced into the first analytical stream.
14. The system of claim 9 wherein the reaction device is user-configurable.
15. A system for regulating flow in a fluidic device, comprising:

One or more fluidic carrier streams, including a first carrier stream having a carrier flow rate;

a first injection means for introducing a first substance into the first carrier stream to make a first stream having a first stream flow rate;

a second injection means for introducing a second substance into the first stream to make a second stream having a second stream flow rate; and

a flow regulator coupled to the first carrier stream, the flow regulator operative to maintain the second stream flow rate at a constant value by adjusting the carrier flow rate to compensate for the introduction of the first substance into the first carrier stream and the second substance into the first stream.

16. The system of claim 15 wherein the first substance comprises a sample and the second substance comprises a reagent.
17. The system of claim 15 wherein the first substance comprises a reagent and the second substance comprises a sample.
18. The system of claim 15 comprising a plurality of fluidic carrier streams with independently regulated carrier flow rates.
19. The system of claim 16 comprising a detector operative to detect a reaction between the sample and the reagent.
20. The system of claim 15 designed and arranged to synthesize a reaction product.
21. The system of claim 15 wherein the flow regulator is upstream of the first injection means and the second injection means.
22. The system of claim 21 wherein the flow regulator senses the carrier flow rate.
23. The system of claim 22 wherein the flow regulator uses the sensed carrier flow rate to maintain the second stream flow rate at the constant value.
24. The system of claim 15 wherein the first injection means comprises a non-peristaltic pump.
25. The system of claim 24 further wherein the first injection means is a syringe pump.
26. The system of claim 15 wherein the flow regulator comprises a fluidic flow controller.
27. The system of claim 26 wherein the fluidic flow controller comprises a controller.
28. The system of claim 26 wherein the fluidic flow controller comprises an orifice.
29. The system of claim 28 wherein the orifice is variable.
30. The system of claim 28 wherein the orifice is controllable.
31. The system of claim 15 wherein the flow regulator comprises a pressure sensor.
32. The system of claim 26 wherein the fluidic flow controller comprises a flow sensor.
33. The system of claim 32 wherein the flow sensor comprises a pressure sensor.
34. The system of claim 26 wherein the flow regulator further comprises a constant pressure fluid delivery system.
35. The system of claim 34 wherein the constant pressure fluid delivery system comprises a non-peristaltic pump.

36. The system of claim 34 wherein the constant pressure fluid delivery system comprises a back pressure regulator.
37. The system of claim 15 further comprising a reaction device through which the second stream flows.
38. The system of claim 37 further comprising a detector downstream of the reaction device.
39. The system of claim 37 wherein the reaction device is user-configurable.
40. The system of claim 37 further comprising a third injection means for introducing a third substance into the second stream downstream of the reaction device.
41. The system of claim 40 further comprising a master controller, the master controller operative to determine the timing and quantity of third substance introduced into the second stream.
42. The system of claim 41 wherein the master controller is further operative to time the introduction of the third substance into the second stream based on at least one of the following: carrier flow rate, first stream flow rate, or second stream flow rate.
43. The system of claim 41 further comprising a user-configurable reaction device wherein the master controller is further operative to time the introduction of the third substance into the second stream based on a configuration of the reaction device.
44. The system of claim 15 further comprising:
 - a second carrier stream having a second carrier flow rate;
 - a third injection means for introducing third first substance into the second carrier stream to make a third stream;
 - a fourth injection means for introducing the second substance into the third stream to make a fourth stream having a fourth stream flow rate; and
 - a second carrier flow regulator coupled to the second carrier stream, the flow regulator operative to maintain the fourth stream flow rate at a constant value by adjusting the second carrier flow rate to compensate for the introduction of the first substance and the second substance into the second carrier stream and third stream.
45. The system of claim 44 further comprising a manifold coupled to each of the one or more fluidic carrier streams.
46. The system of claim 44 wherein the flow regulator and the second carrier flow regulator are the same.
47. The system of claim 44 wherein the second flow regulator is further operative to adjust the second carrier flow rate independently of the carrier flow rate.
48. The system of claim 44 wherein the timing of introduction of the first substance into the second carrier stream or the amount of the first substance introduced into the second carrier stream differs from the timing or amount of the first substance introduced into the first carrier stream.
49. The system of claim 44 wherein the timing of introduction of the second substance into the third stream or the amount of the second substance introduced into the third stream differs from the timing or amount of the second substance introduced into the second stream.

50. The system of claim 44 wherein the second carrier stream and first carrier stream flow through different conduits.
51. The system of claim 50 wherein the second stream flows through a first reaction device and the fourth stream flows through a second reaction device that differs in configuration from the first reaction device.
52. A sample and reagent addition system, comprising:
a carrier stream, wherein characteristics of the system allow location of components within the carrier stream in the system to be known;
a pump, wherein the pump is non-pulsatile, and wherein the pump continuously pumps the carrier stream;
a sample introduction device, wherein the sample introduction device introduces a sample to the carrier stream to provide a sample carrier stream; and
a reagent addition device to enable continuous or intermittent timed additions of reagents to the sample carrier stream at a desired location in the sample and reagent addition system.
53. A system for regulating fluid flow to a detector of a fluidic device, said system comprising:
a constant flow pump to deliver a transport medium to a manifold;
a back pressure regulator in fluid communication with said manifold arranged and designed to maintain pressure at said manifold at a constant;
a flow element in fluid communication with said manifold, said flow element designed to permit transport medium from said manifold to flow therethrough,
a valve disposed within said flow element to control said flow of transport medium therethrough; said transport medium creating an analytical stream within said flow element;
a syringe pump to inject a volume of sample into said analytical stream of said flow element at a position downstream of said valve;
at least one reagent inlet for injecting a reagent into said analytical stream of said flow element;
at least one mixing volume disposed within said flow element at a position downstream of said at least one reagent inlet, said mixing volume arranged and designed to permit a reaction between said reagent and said sample to create a reaction product;
a detector to analyze said reaction product; and
a flow controller arranged and designed to control said valve, said syringe pump, and said reagent injection such that a constant flow of said analytical stream containing said reaction product is delivered to said detector.
54. A method for regulating flow in a fluidic device, comprising:
delivering a first carrier stream, said first carrier stream being fluidic and having a first carrier stream flow rate, said first carrier stream flow rate being substantially constant and initially substantially equal to a first target flow rate;
introducing a first substance into the first carrier stream to make a first stream having a first stream flow rate;

- regulating the first carrier stream flow rate so that the first stream flow rate remains substantially constant;
- introducing a second substance into the first stream to make a second stream having a second stream flow rate; and
- further regulating the first carrier stream flow rate so that the second stream flow rate remains substantially constant.
55. The method of claim 54 wherein the first stream comprises a reagent and the second stream comprises a sample.
 56. The method of claim 54 wherein the first stream comprises a sample and the second stream comprises a reagent.
 57. The method of claim 56 further comprising detecting a reaction of the sample and the reagent.
 58. The method of claim 56 further comprising synthesizing a reaction product of the sample and the reagent.
 59. The method of claim 54 further comprising reversing the flow of the first stream or the second stream.
 60. The method of claim 54 wherein the first stream flow rate is substantially equal to the target flow rate.
 61. The method of claim 54 wherein the second stream flow rate is substantially equal to the first target flow rate.
 62. The method of claim 54 further comprising sensing the first carrier stream flow rate.
 63. The method of claim 62 wherein sensing the first carrier stream flow rate comprises sensing a first carrier stream pressure.
 64. The method of claim 63 further comprising maintaining a substantially constant second stream flow rate without sensing the second stream flow rate.
 65. The method of claim 63 wherein sensing the first carrier stream pressure comprises using a pressure sensor.
 66. The method of claim 54 wherein wherein delivering the first carrier stream at a substantially constant first carrier stream flow rate comprises using a pump.
 67. The method of claim 66 wherein the pump is non-peristaltic.
 68. The method of claim 54 wherein delivering the first carrier stream at a substantially constant first carrier stream flow rate further comprises providing the first carrier stream at a constant pressure.
 69. The method of claim 54 wherein regulating the first carrier stream flow rate further comprises channeling the first carrier stream at a substantially constant pressure through an orifice.
 70. The method of claim 69 wherein regulating the first carrier stream flow rate further comprises controllably changing the size of the orifice.
 71. The method of claim 70 wherein the orifice is voltage-controlled.
 72. The method of claim 54 wherein introducing the first substance into the first carrier stream comprises using a pump.

73. The method of claim 72 wherein the pump comprises a syringe pump.
74. The method of claim 73 wherein the pump is non-peristaltic.
75. The method of claim 54 wherein the second stream flows through a reaction device.
76. The method of claim 75 further comprising introducing a third substance into the second stream downstream of the reaction device.
77. The method of claim 76 further comprising determining the timing of the introduction of the third substance into the second stream based on at least one of the following: first carrier stream flow rate; first target flow rate; first stream flow rate; second stream flow rate.
78. The method of claim 75 wherein the reaction device is user-configurable.
79. The method of claim 78 further comprising determining the timing of the introduction of the third substance based on a configuration of the reaction device.
80. The method of claim 54 further comprising delivering a second carrier stream, said second carrier stream being fluidic and having a second carrier stream flow rate, said second carrier stream flow rate being substantially constant and initially substantially equal to a second target flow rate;
introducing the first substance into the second carrier stream to make a third stream having a third stream flow rate;
regulating the second carrier stream flow rate so that the third stream flow rate remains substantially constant;
introducing the second substance into the third stream to make a fourth stream having a fourth stream flow rate; and
further regulating the second carrier stream flow rate so that the fourth stream flow rate remains substantially constant.
81. The method of claim 80 further comprising regulating the second carrier stream flow rate independently of the first carrier stream flow rate.
82. The method of claim 80 wherein the timing of introduction of the first substance into the second carrier stream or the amount of the first substance introduced into the second carrier stream differs from the timing or amount of the first substance introduced into the first carrier stream.
83. The method of claim 80 wherein the timing of introduction of the second substance into the third stream or the amount of the second substance introduced into the third stream differs from the timing or amount of the second substance introduced into the second stream.
84. The method of claim 80 wherein the second carrier stream and first carrier stream flow through different conduits.
85. The method of claim 84 wherein the second stream flows through a first reaction device and the fourth stream flows through a second reaction device that differs in configuration from the first reaction device.

AMENDED CLAIMS**received by the International Bureau on 30 April 2009 (30.04.2009)**

1. (Currently Amended) A system for regulating flow in a fluidic device, comprising:
one or more analytical streams comprising a transport medium and flowing through:
a pumping system and flow control module;
a sample introduction module;
~~a sample reaction module; and~~
~~a sample detection module.~~
a sample reaction module, the sample reaction module comprising a reaction device in a first analytical stream, the reaction device comprising an analyte produced by a reaction between a sample introduced by the sample introduction module into the first analytical stream and a reagent introduced by the sample reaction module into the first analytical stream;
a sample detection module, wherein the analyte is detected by a detector comprised in the sample detection module and the analyte has a constant flow at the detector;
wherein the pumping system and flow control module maintains a constant flow rate of the analyte at the detector by controlling the flow of transport medium in the first analytical stream to compensate for the sample and the reagent introduced into the first analytical stream.
2. (Canceled) The system of claim 1 wherein the pumping system and flow control module controls the flow of transport medium in the one or more analytical streams to maintain a constant flow at a detector comprised in the sample detection module.
3. (Canceled) The system of claim 1 wherein the pumping system and flow control module comprises at least one fluidic flow controller.
4. (Canceled) The system of claim 3 wherein the at least one fluidic flow controller comprises controls a variable-sized orifice for each of the one or more analytical streams.
5. (Canceled) The system of claim 4 wherein the pumping system and flow control module comprises a non-peristaltic pump that provides transport medium at a constant pressure to the variable sized orifice for each of the one or more analytical streams.
6. (Canceled) The system of claim 1 wherein the sample introduction module comprises a syringe pump.
7. (Canceled) The system of claim 6 wherein the sample introduction module further comprises an isolation loop.
8. (Canceled) The system of claim 1 wherein the sample reaction module comprises at least one reagent inlet in each of the one or more analytical streams.
9. (Canceled) The system of claim 1 wherein the sample reaction module further comprises a reaction device in a first analytical stream.
10. (Canceled) The system of claim 9 wherein the reaction device comprises an analyte produced by a reaction between a sample introduced by the sample introduction module

- into the first analytical stream and a reagent introduced by the sample reaction module into the first analytical stream.
11. (Canceled) The system of claim 10 wherein the analyte is detected by a detector comprised in the sample detection module.
 12. (Canceled) The system of claim 11 wherein the analyte has a constant flow at the detector.
 13. (Canceled) The system of claim 12 wherein the pumping system and flow control module maintains a constant flow rate of the analyte at the detector by controlling the flow of transport medium in the first analytical stream to compensate for the sample and the reagent introduced into the first analytical stream.
 14. (Canceled) The system of claim 9 wherein the reaction device is user-configurable.
 15. (Original) A system for regulating flow in a fluidic device, comprising:
One or more fluidic carrier streams, including a first carrier stream having a carrier flow rate;
a first injection means for introducing a first substance into the first carrier stream to make a first stream having a first stream flow rate;
a second injection means for introducing a second substance into the first stream to make a second stream having a second stream flow rate; and
a flow regulator coupled to the first carrier stream, the flow regulator operative to maintain the second stream flow rate at a constant value by adjusting the carrier flow rate to compensate for the introduction of the first substance into the first carrier stream and the second substance into the first stream.
 16. (Original) The system of claim 15 wherein the first substance comprises a sample and the second substance comprises a reagent.
 17. (Original) The system of claim 15 wherein the first substance comprises a reagent and the second substance comprises a sample.
 18. (Original) The system of claim 15 comprising a plurality of fluidic carrier streams with independently regulated carrier flow rates.
 19. (Original) The system of claim 16 comprising a detector operative to detect a reaction between the sample and the reagent.
 20. (Original) The system of claim 15 designed and arranged to synthesize a reaction product.
 21. (Original) The system of claim 15 wherein the flow regulator is upstream of the first injection means and the second injection means.
 22. (Original) The system of claim 21 wherein the flow regulator senses the carrier flow rate.
 23. (Original) The system of claim 22 wherein the flow regulator uses the sensed carrier flow rate to maintain the second stream flow rate at the constant value.
 24. (Original) The system of claim 15 wherein the first injection means comprises a non-peristaltic pump.
 25. (Original) The system of claim 24 further wherein the first injection means is a syringe pump.

26. (Original) The system of claim 15 wherein the flow regulator comprises a fluidic flow controller.
27. (Original) The system of claim 26 wherein the fluidic flow controller comprises a controller.
28. (Original) The system of claim 26 wherein the fluidic flow controller comprises an orifice.
29. (Original) The system of claim 28 wherein the orifice is variable.
30. (Original) The system of claim 28 wherein the orifice is controllable.
31. (Original) The system of claim 15 wherein the flow regulator comprises a pressure sensor.
32. (Original) The system of claim 26 wherein the fluidic flow controller comprises a flow sensor.
33. (Original) The system of claim 32 wherein the flow sensor comprises a pressure sensor.
34. (Original) The system of claim 26 wherein the flow regulator further comprises a constant pressure fluid delivery system.
35. (Original) The system of claim 34 wherein the constant pressure fluid delivery system comprises a non-peristaltic pump.
36. (Original) The system of claim 34 wherein the constant pressure fluid delivery system comprises a back pressure regulator.
37. (Original) The system of claim 15 further comprising a reaction device through which the second stream flows.
38. (Original) The system of claim 37 further comprising a detector downstream of the reaction device.
39. (Original) The system of claim 37 wherein the reaction device is user-configurable.
40. (Original) The system of claim 37 further comprising a third injection means for introducing a third substance into the second stream downstream of the reaction device.
41. (Original) The system of claim 40 further comprising a master controller, the master controller operative to determine the timing and quantity of third substance introduced into the second stream.
42. (Original) The system of claim 41 wherein the master controller is further operative to time the introduction of the third substance into the second stream based on at least one of the following: carrier flow rate, first stream flow rate, or second stream flow rate.
43. (Original) The system of claim 41 further comprising a user-configurable reaction device wherein the master controller is further operative to time the introduction of the third substance into the second stream based on a configuration of the reaction device.
44. (Original) The system of claim 15 further comprising:
a second carrier stream having a second carrier flow rate;

a third injection means for introducing third first substance into the second carrier stream to make a third stream;

a fourth injection means for introducing the second substance into the third stream to make a fourth stream having a fourth stream flow rate; and

a second carrier flow regulator coupled to the second carrier stream, the flow regulator operative to maintain the fourth stream flow rate at a constant value by adjusting the second carrier flow rate to compensate for the introduction of the first substance and the second substance into the second carrier stream and third stream.

45. (Original) The system of claim 44 further comprising a manifold coupled to each of the one or more fluidic carrier streams.
46. (Original) The system of claim 44 wherein the flow regulator and the second carrier flow regulator are the same.
47. (Original) The system of claim 44 wherein the second flow regulator is further operative to adjust the second carrier flow rate independently of the carrier flow rate.
48. (Original) The system of claim 44 wherein the timing of introduction of the first substance into the second carrier stream or the amount of the first substance introduced into the second carrier stream differs from the timing or amount of the first substance introduced into the first carrier stream.
49. (Original) The system of claim 44 wherein the timing of introduction of the second substance into the third stream or the amount of the second substance introduced into the third stream differs from the timing or amount of the second substance introduced into the second stream.
50. (Original) The system of claim 44 wherein the second carrier stream and first carrier stream flow through different conduits.
51. (Original) The system of claim 50 wherein the second stream flows through a first reaction device and the fourth stream flows through a second reaction device that differs in configuration from the first reaction device.
52. (Original) A sample and reagent addition system, comprising:
a carrier stream, wherein characteristics of the system allow location of components within the carrier stream in the system to be known;
a pump, wherein the pump is non-pulsatile, and wherein the pump continuously pumps the carrier stream;
a sample introduction device, wherein the sample introduction device introduces a sample to the carrier stream to provide a sample carrier stream; and
a reagent addition device to enable continuous or intermittent timed additions of reagents to the sample carrier stream at a desired location in the sample and reagent addition system.
53. (Original) A system for regulating fluid flow to a detector of a fluidic device, said system comprising:
a constant flow pump to deliver a transport medium to a manifold;
a back pressure regulator in fluid communication with said manifold arranged and designed to maintain pressure at said manifold at a constant;

a flow element in fluid communication with said manifold, said flow element designed to permit transport medium from said manifold to flow therethrough,

a valve disposed within said flow element to control said flow of transport medium therethrough; said transport medium creating an analytical stream within said flow element;

a syringe pump to inject a volume of sample into said analytical stream of said flow element at a position downstream of said valve;

at least one reagent inlet for injecting a reagent into said analytical stream of said flow element;

at least one mixing volume disposed within said flow element at a position downstream of said at least one reagent inlet, said mixing volume arranged and designed to permit a reaction between said reagent and said sample to create a reaction product;

a detector to analyze said reaction product; and

a flow controller arranged and designed to control said valve, said syringe pump, and said reagent injection such that a constant flow of said analytical stream containing said reaction product is delivered to said detector.

54. (Original) A method for regulating flow in a fluidic device, comprising:

delivering a first carrier stream, said first carrier stream being fluidic and having a first carrier stream flow rate, said first carrier stream flow rate being substantially constant and initially substantially equal to a first target flow rate;

introducing a first substance into the first carrier stream to make a first stream having a first stream flow rate;

regulating the first carrier stream flow rate so that the first stream flow rate remains substantially constant;

introducing a second substance into the first stream to make a second stream having a second stream flow rate; and

further regulating the first carrier stream flow rate so that the second stream flow rate remains substantially constant.

55. (Original) The method of claim 54 wherein the first stream comprises a reagent and the second stream comprises a sample.

56. (Original) The method of claim 54 wherein the first stream comprises a sample and the second stream comprises a reagent.

57. (Original) The method of claim 56 further comprising detecting a reaction of the sample and the reagent.

58. (Original) The method of claim 56 further comprising synthesizing a reaction product of the sample and the reagent.

59. (Original) The method of claim 54 further comprising reversing the flow of the first stream or the second stream.

60. (Original) The method of claim 54 wherein the first stream flow rate is substantially equal to the target flow rate.

61. (Original) The method of claim 54 wherein the second stream flow rate is substantially equal to the first target flow rate.

62. (Original) The method of claim 54 further comprising sensing the first carrier stream flow rate.
63. (Original) The method of claim 62 wherein sensing the first carrier stream flow rate comprises sensing a first carrier stream pressure.
64. (Original) The method of claim 63 further comprising maintaining a substantially constant second stream flow rate without sensing the second stream flow rate.
65. (Original) The method of claim 63 wherein sensing the first carrier stream pressure comprises using a pressure sensor.
66. (Original) The method of claim 54 wherein delivering the first carrier stream at a substantially constant first carrier stream flow rate comprises using a pump.
67. (Original) The method of claim 66 wherein the pump is non-peristaltic.
68. (Original) The method of claim 54 wherein delivering the first carrier stream at a substantially constant first carrier stream flow rate further comprises providing the first carrier stream at a constant pressure.
69. (Original) The method of claim 54 wherein regulating the first carrier stream flow rate further comprises channeling the first carrier stream at a substantially constant pressure through an orifice.
70. (Original) The method of claim 69 wherein regulating the first carrier stream flow rate further comprises controllably changing the size of the orifice.
71. (Original) The method of claim 70 wherein the orifice is voltage-controlled.
72. (Original) The method of claim 54 wherein introducing the first substance into the first carrier stream comprises using a pump.
73. (Original) The method of claim 72 wherein the pump comprises a syringe pump.
74. (Original) The method of claim 73 wherein the pump is non-peristaltic.
75. (Original) The method of claim 54 wherein the second stream flows through a reaction device.
76. (Original) The method of claim 75 further comprising introducing a third substance into the second stream downstream of the reaction device.
77. (Original) The method of claim 76 further comprising determining the timing of the introduction of the third substance into the second stream based on at least one of the following: first carrier stream flow rate; first target flow rate; first stream flow rate; second stream flow rate.
78. (Original) The method of claim 75 wherein the reaction device is user-configurable.
79. (Original) The method of claim 78 further comprising determining the timing of the introduction of the third substance based on a configuration of the reaction device.
80. (Original) The method of claim 54 further comprising delivering a second carrier stream, said second carrier stream being fluidic and having a second carrier stream flow rate, said second carrier stream flow rate being substantially constant and initially substantially equal to a second target flow rate;
introducing the first substance into the second carrier stream to make a third stream having a third stream flow rate;

regulating the second carrier stream flow rate so that the third stream flow rate remains substantially constant;

introducing the second substance into the third stream to make a fourth stream having a fourth stream flow rate; and

further regulating the second carrier stream flow rate so that the fourth stream flow rate remains substantially constant.

81. (Original) The method of claim 80 further comprising regulating the second carrier stream flow rate independently of the first carrier stream flow rate.
82. (Original) The method of claim 80 wherein the timing of introduction of the first substance into the second carrier stream or the amount of the first substance introduced into the second carrier stream differs from the timing or amount of the first substance introduced into the first carrier stream.
83. (Original) The method of claim 80 wherein the timing of introduction of the second substance into the third stream or the amount of the second substance introduced into the third stream differs from the timing or amount of the second substance introduced into the second stream.
84. (Original) The method of claim 80 wherein the second carrier stream and first carrier stream flow through different conduits.
85. (Original) The method of claim 84 wherein the second stream flows through a first reaction device and the fourth stream flows through a second reaction device that differs in configuration from the first reaction device.

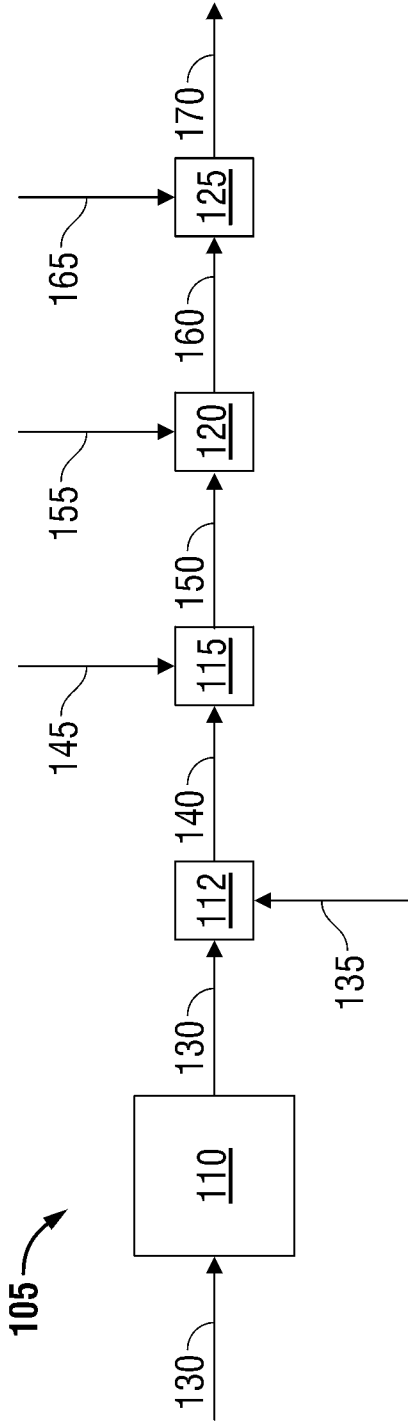

FIG. 1

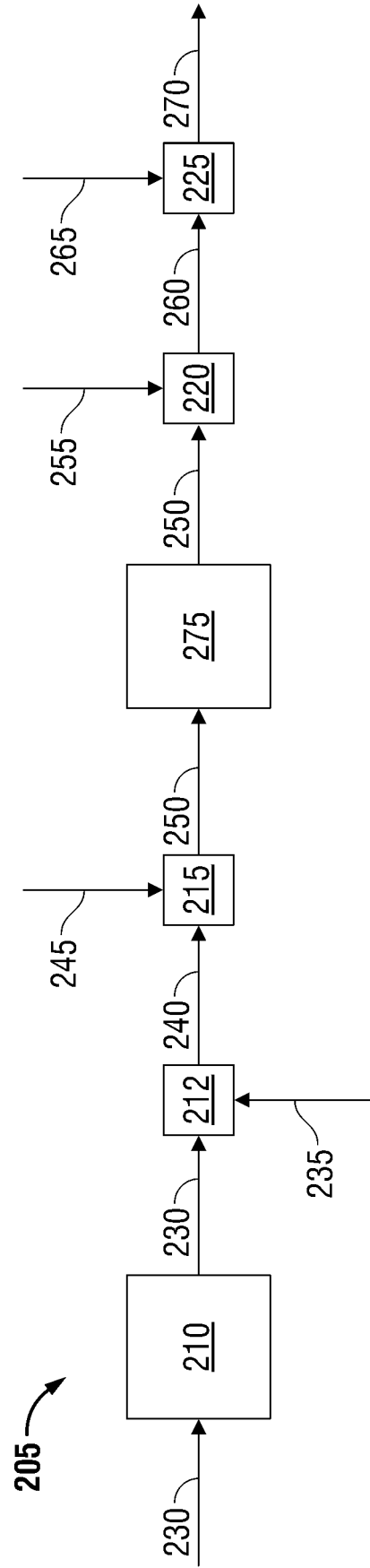

FIG. 2

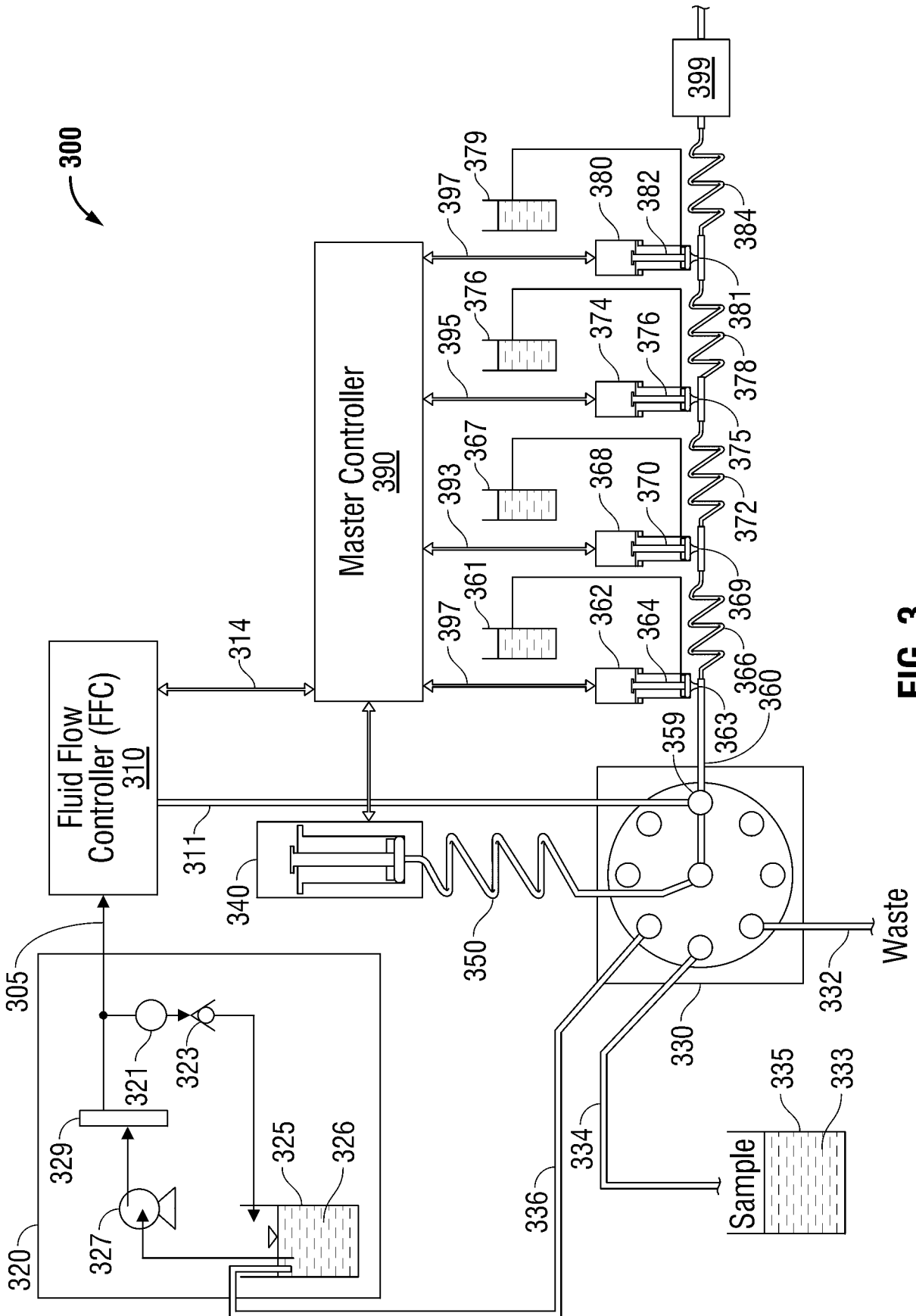

FIG. 3

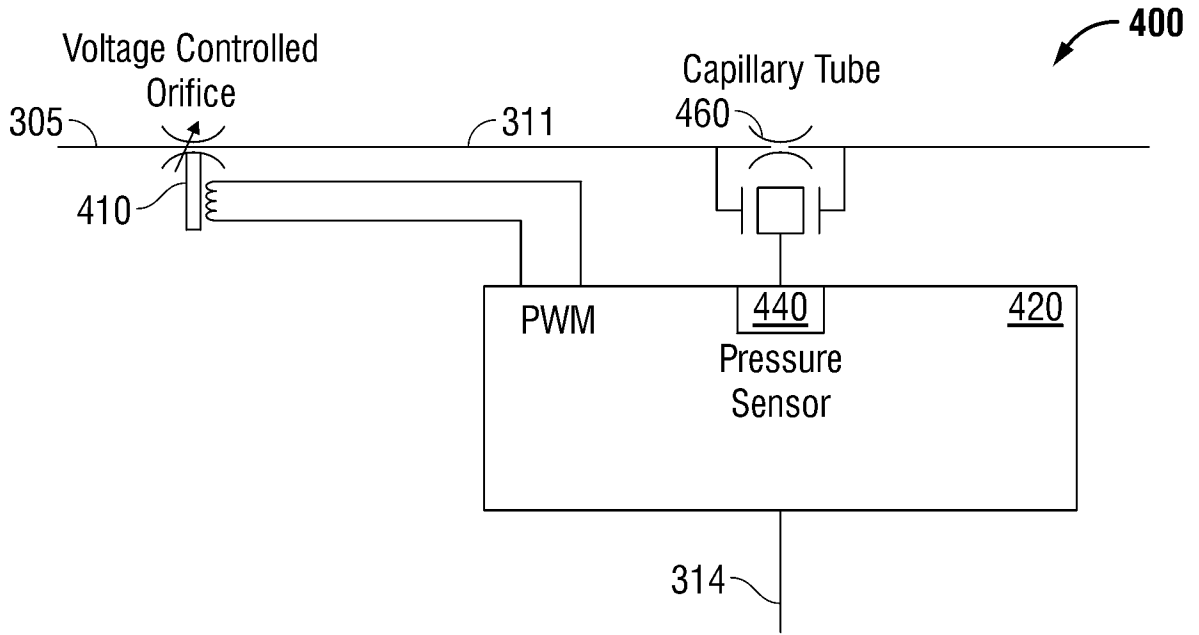

FIG. 4

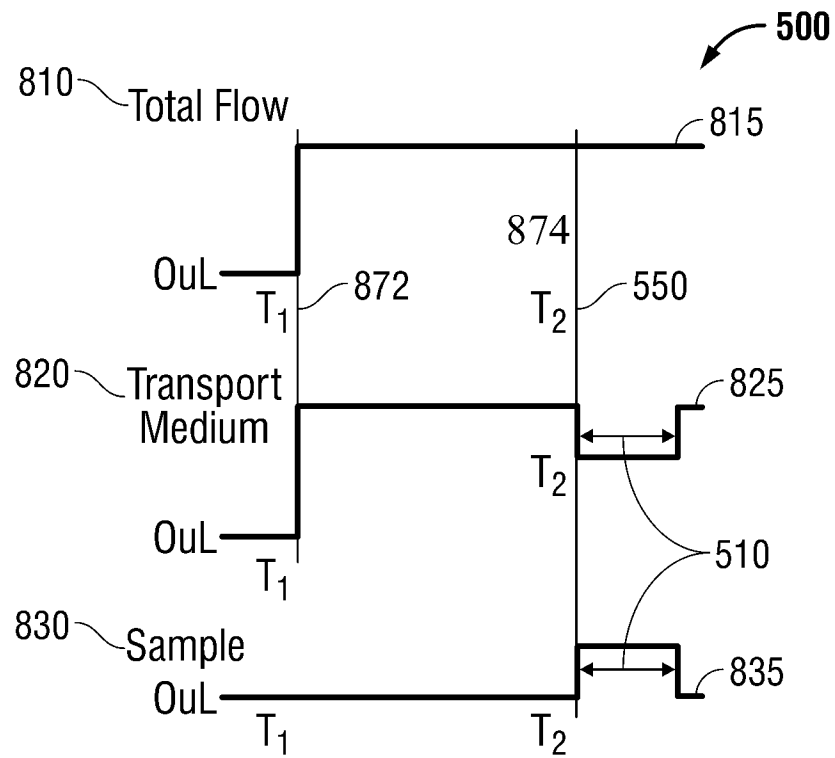

FIG. 5

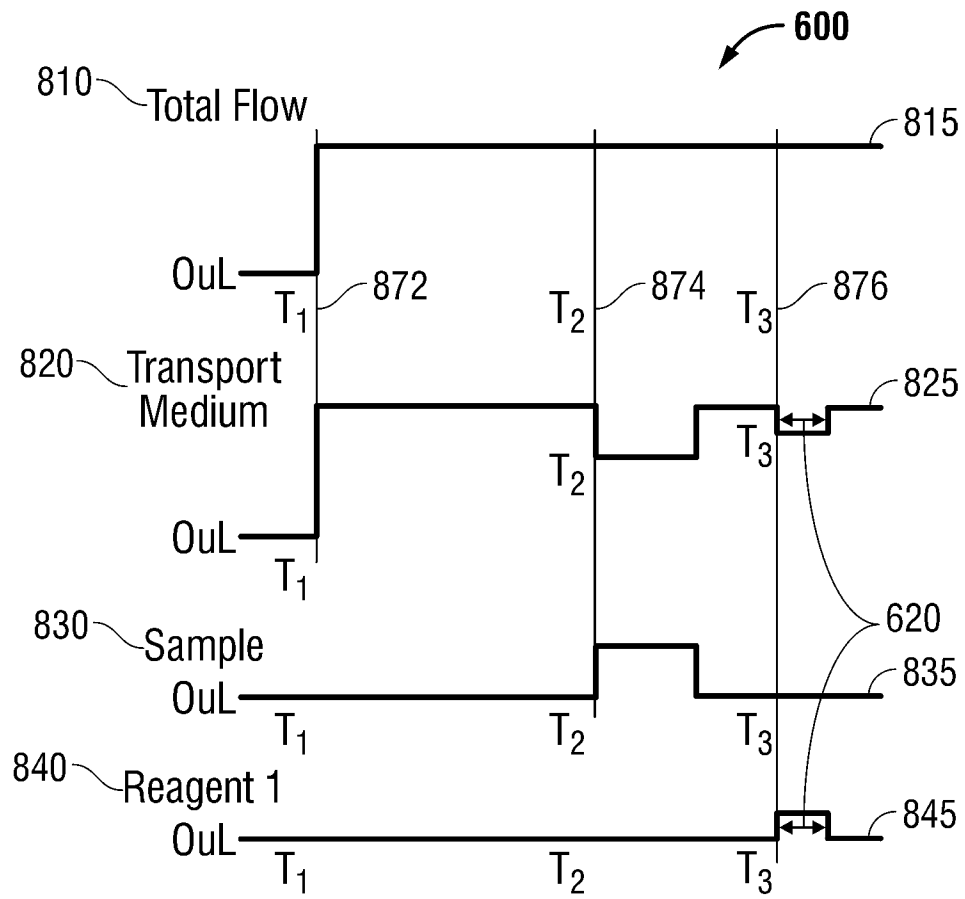

FIG. 6

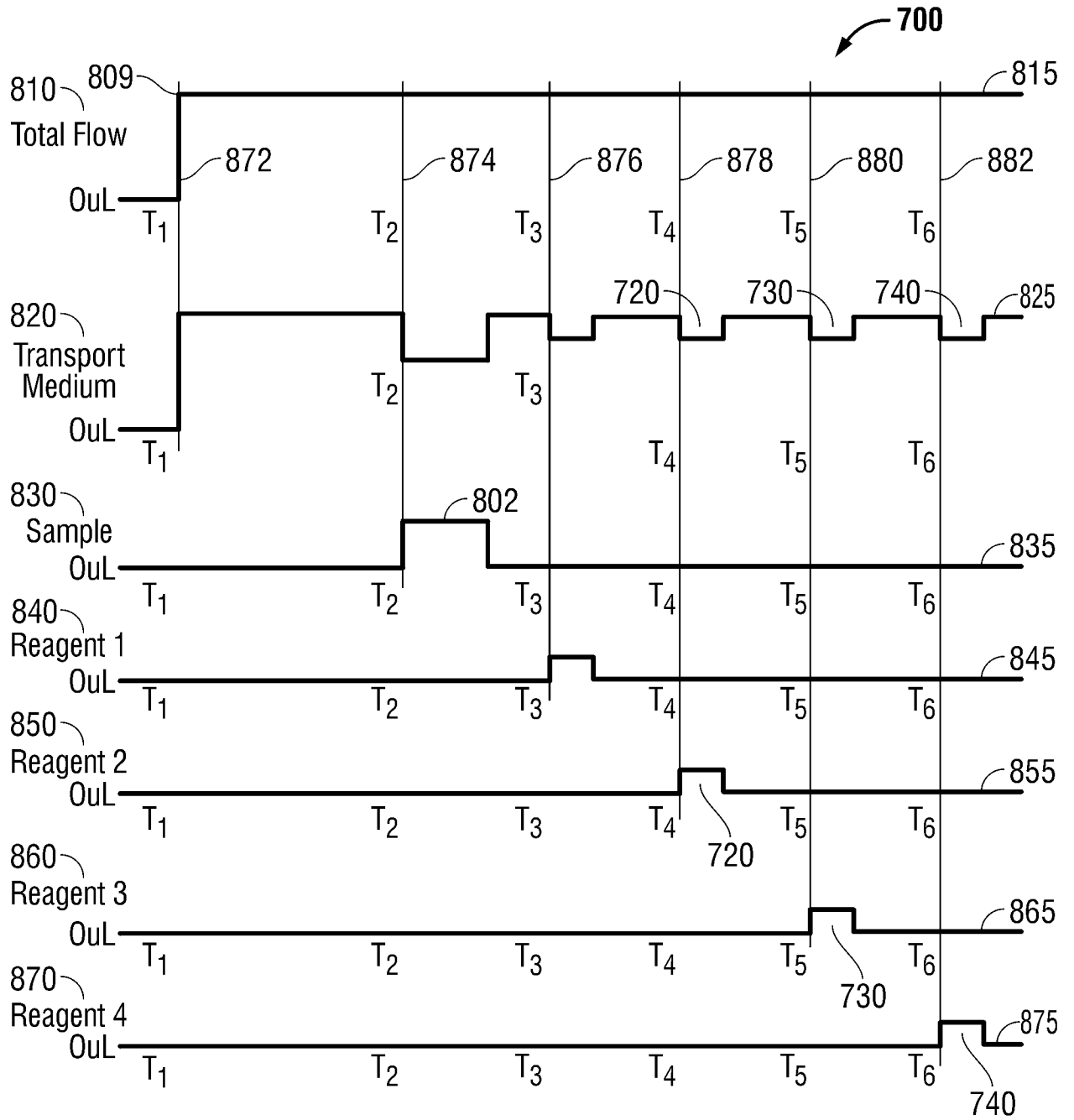

FIG. 7

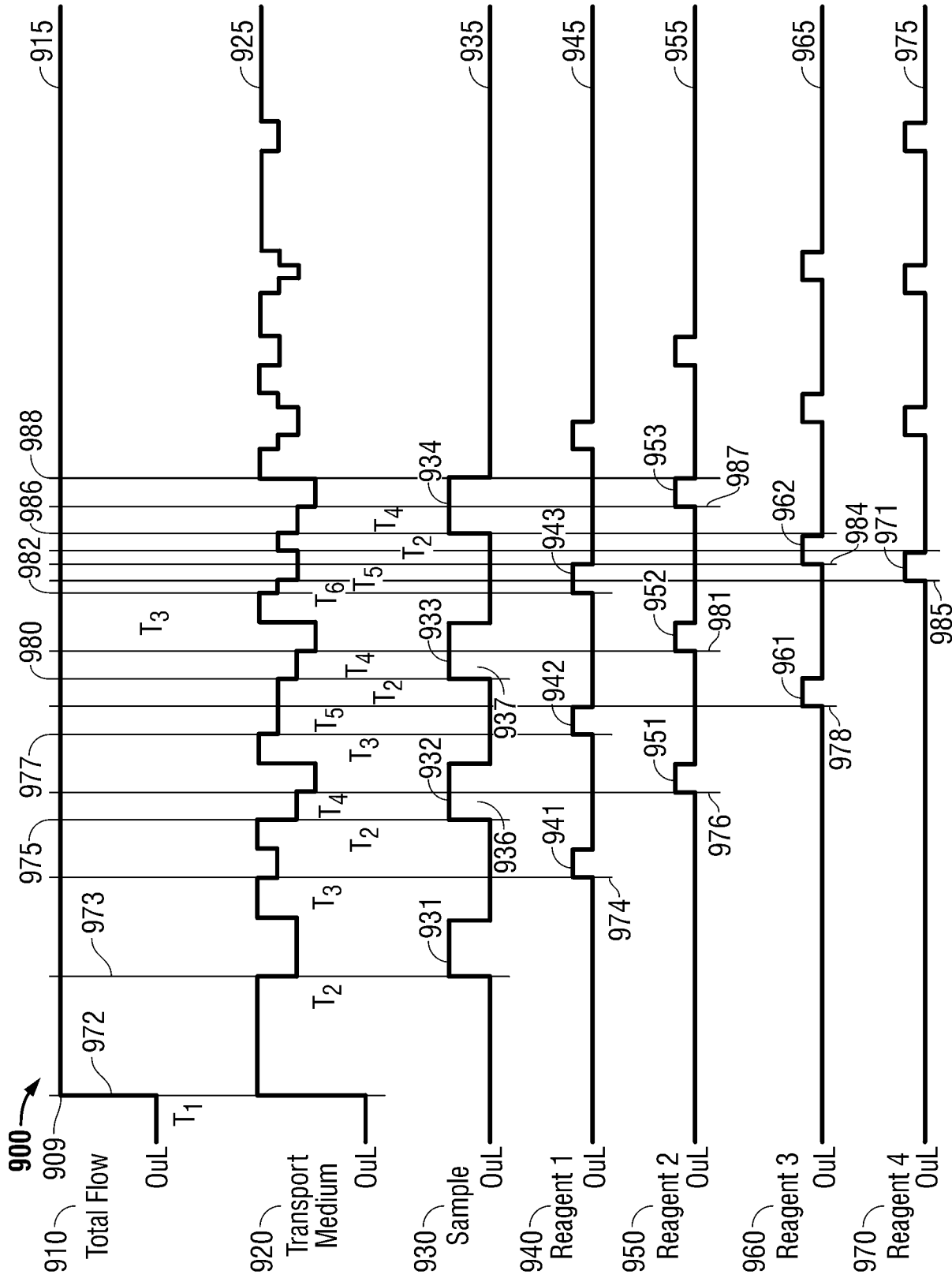

FIG. 9

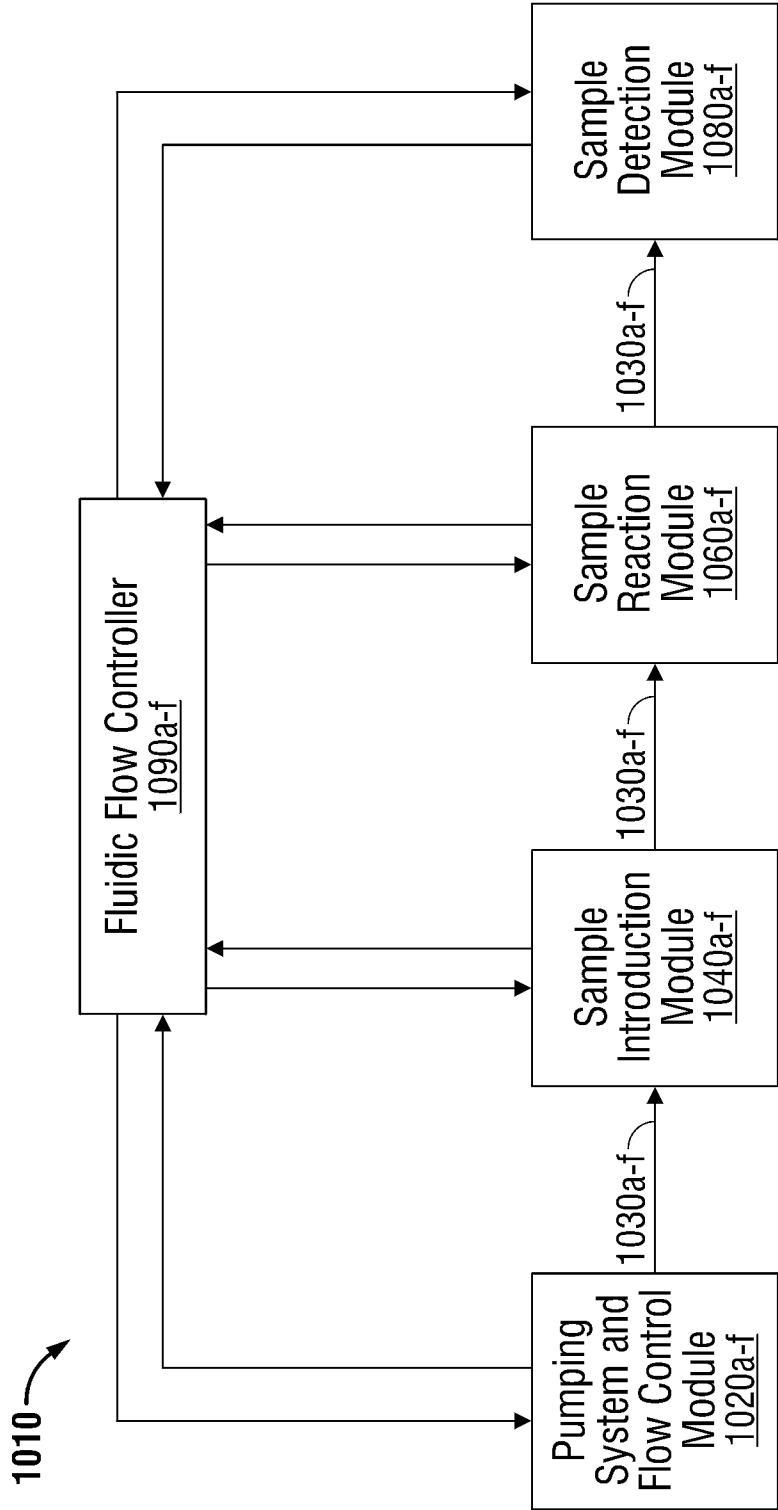

FIG. 10

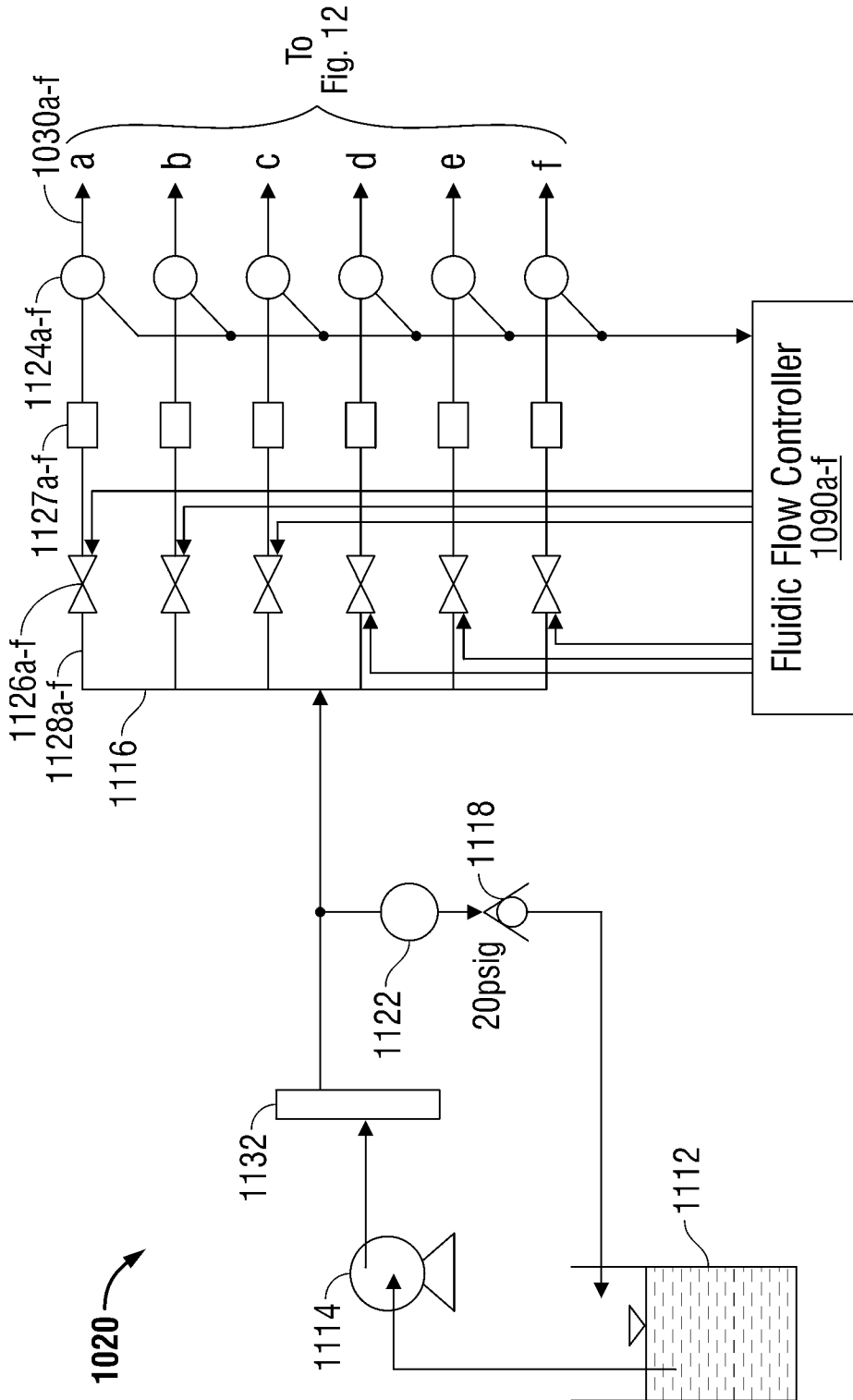

FIG. 11

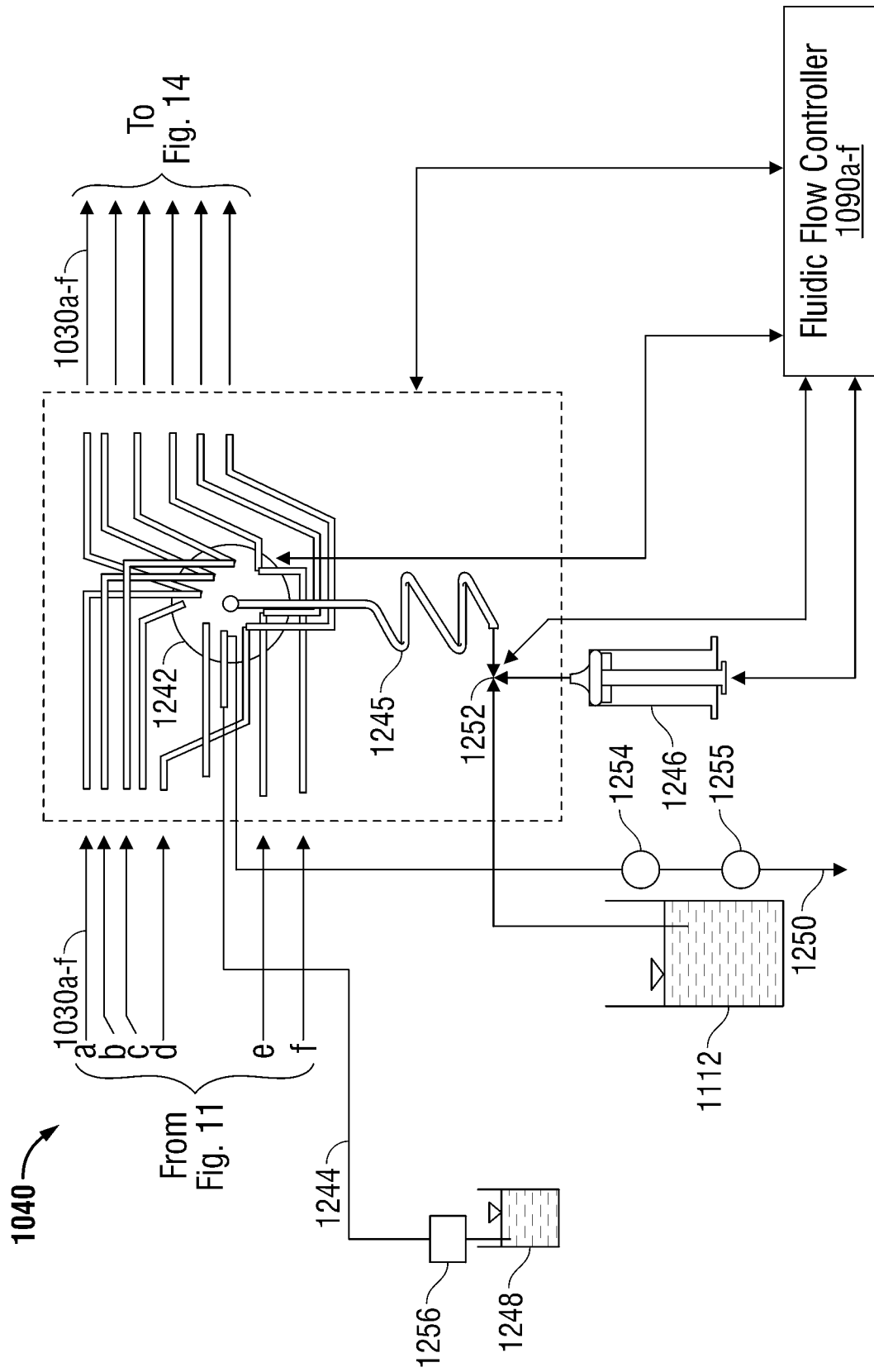

FIG. 12

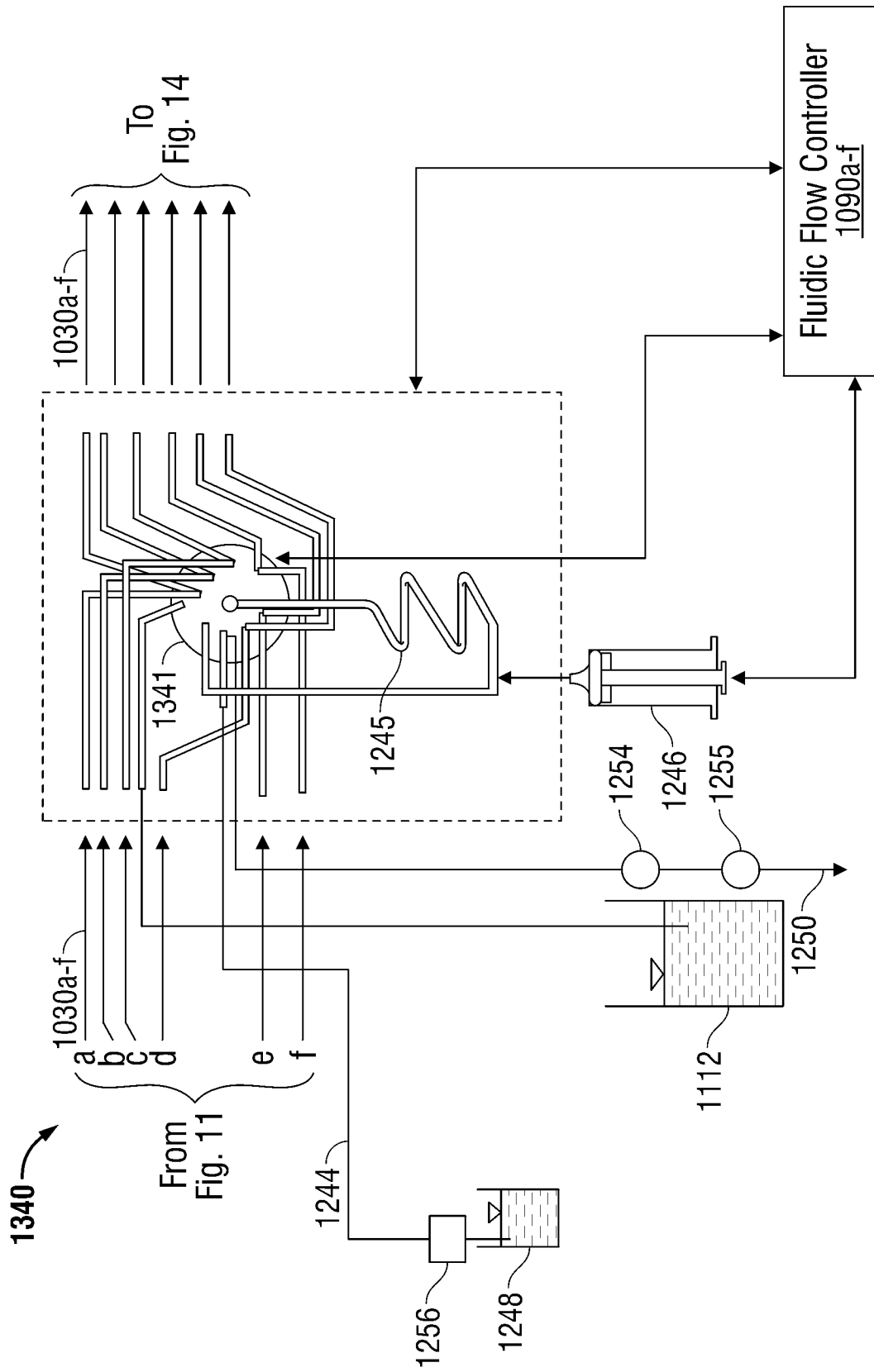
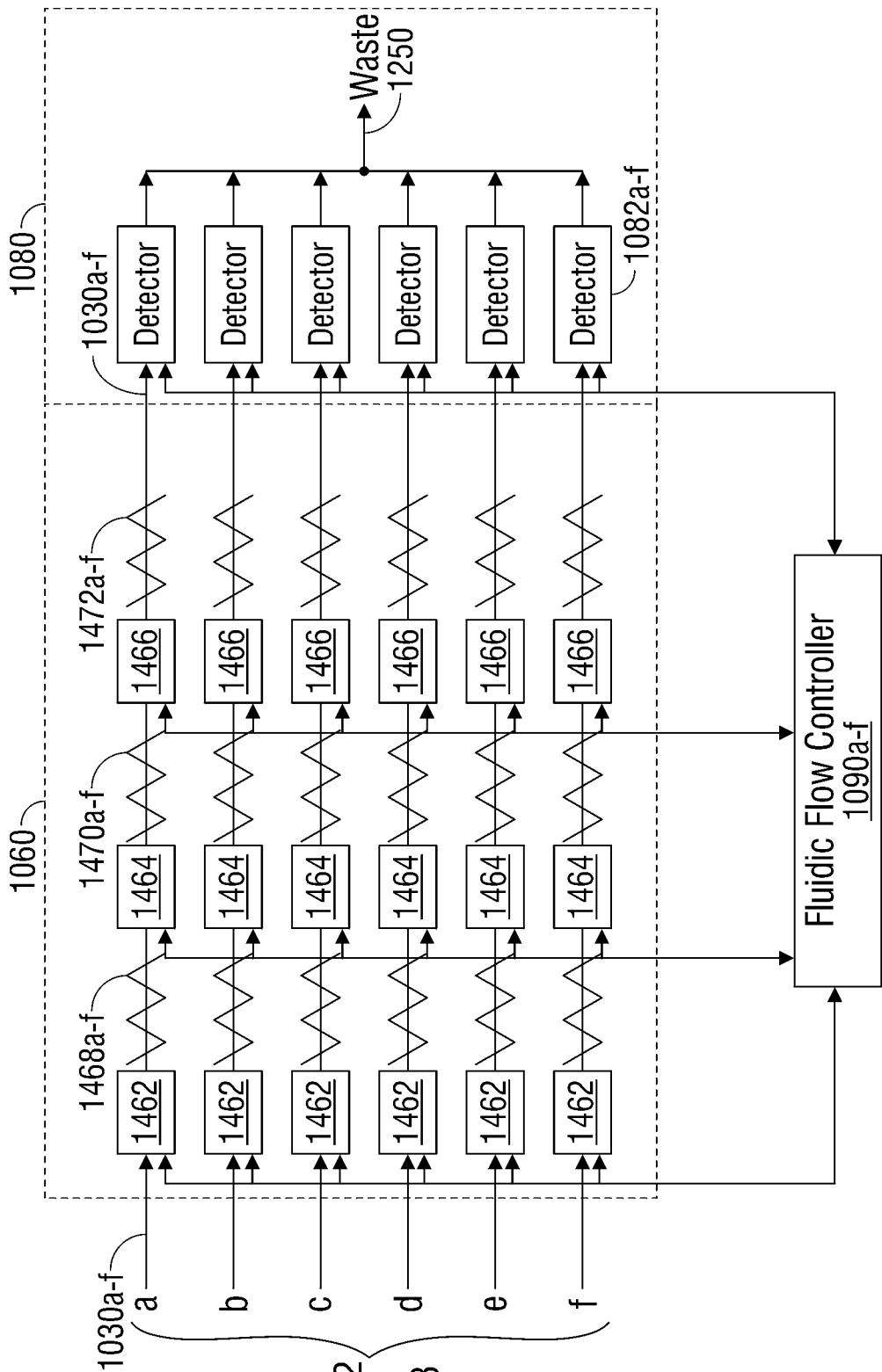

FIG. 13



From
Fig. 12
Or
Fig 13

FIG. 14

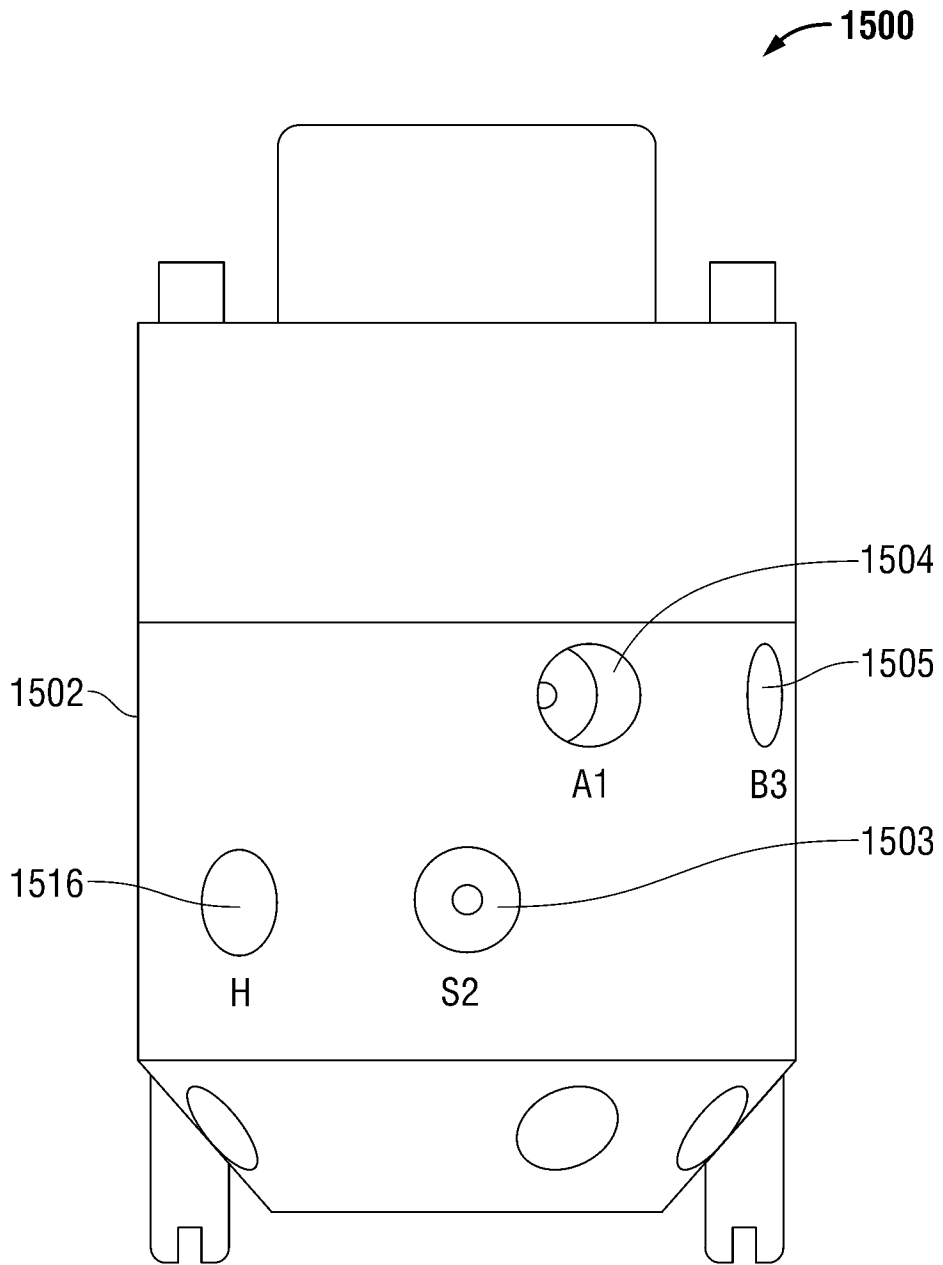

FIG. 15A

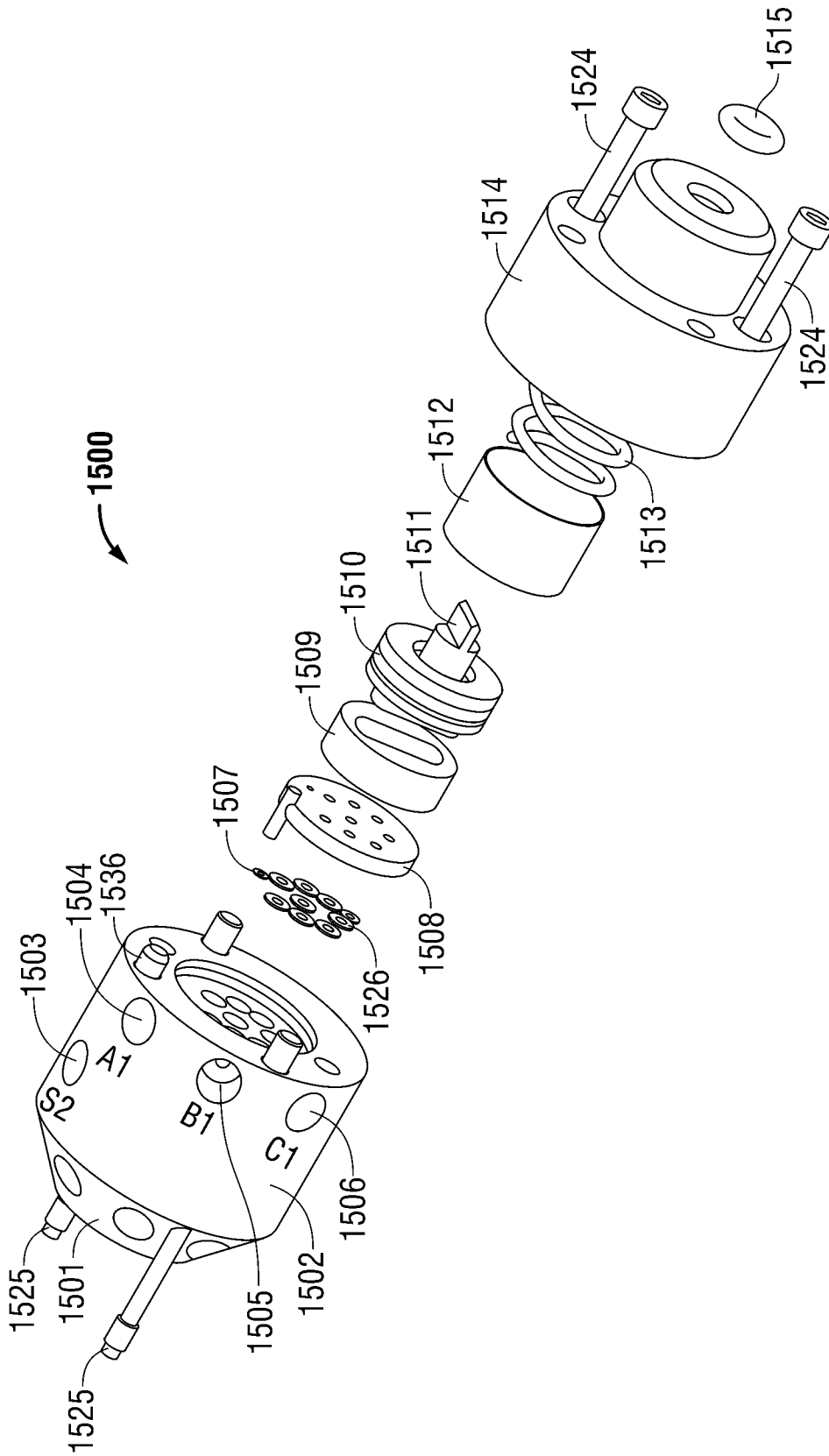

FIG. 15B

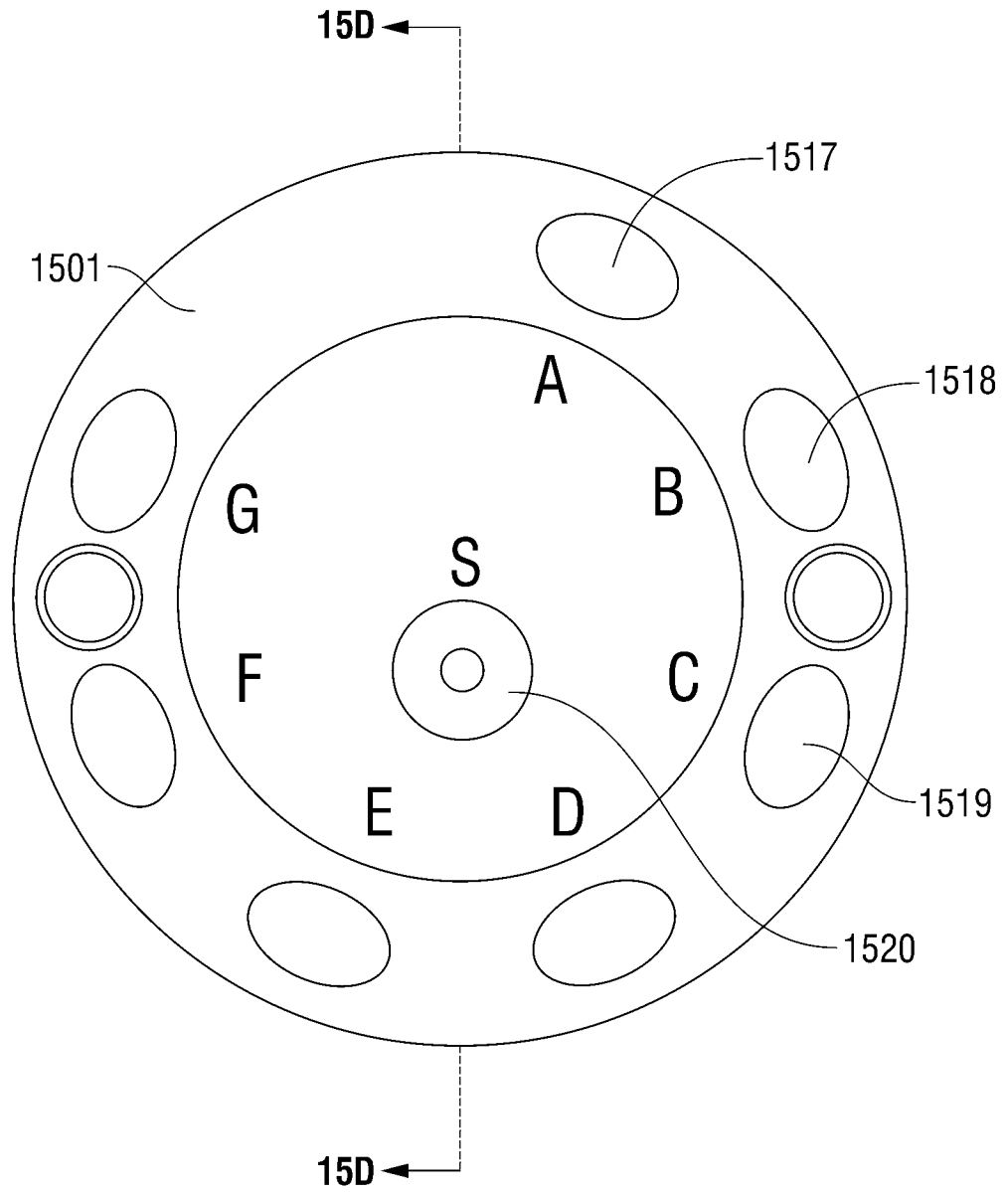

FIG. 15C

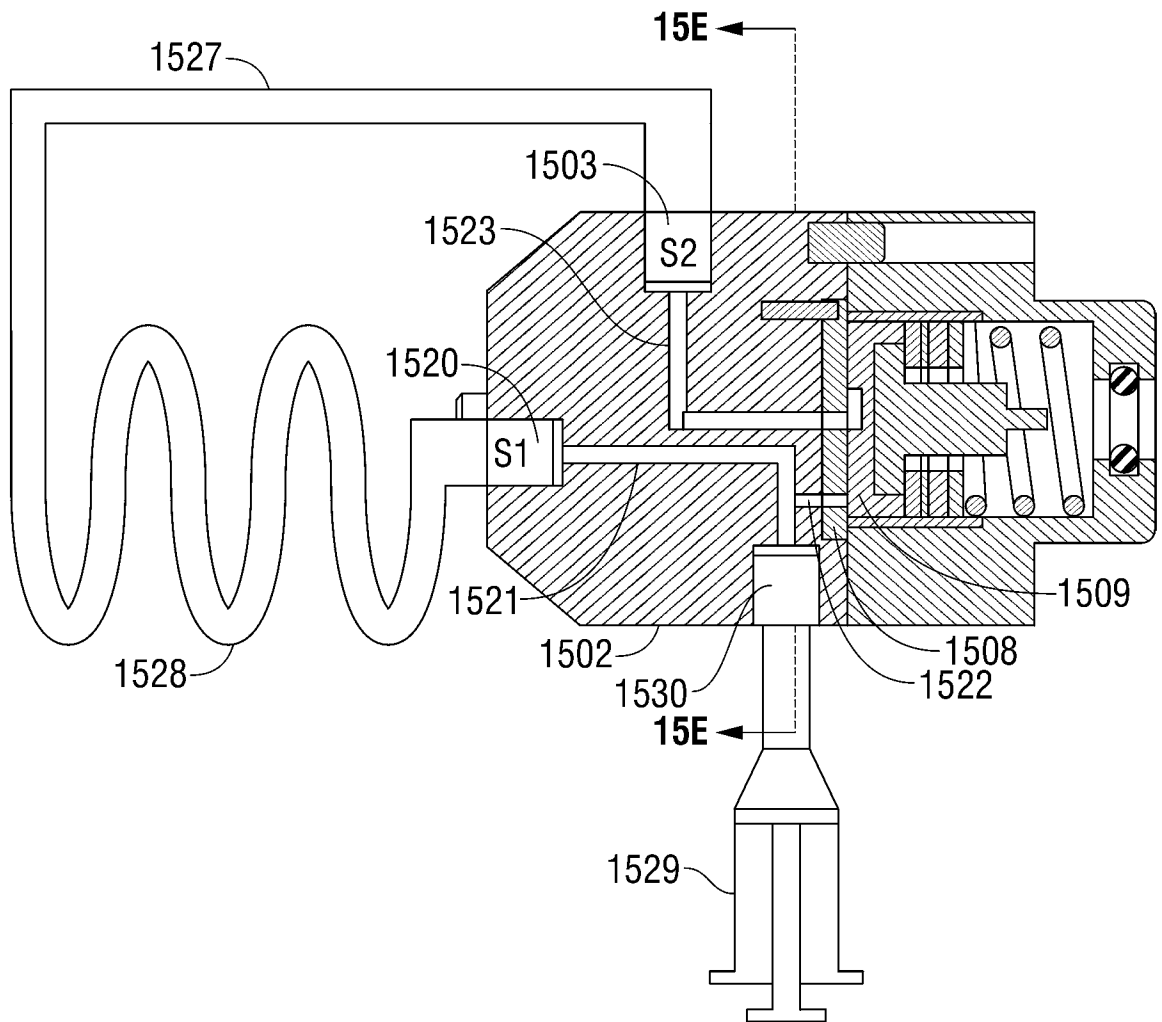

FIG. 15D

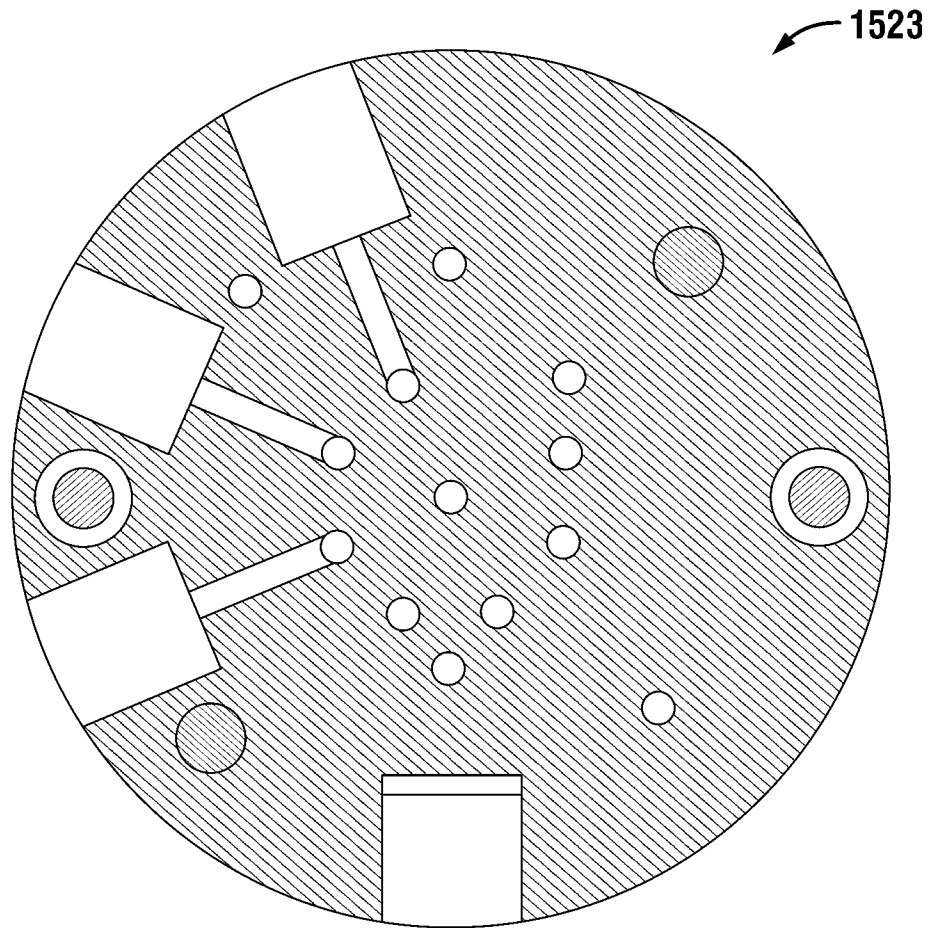

FIG. 15E

INTERNATIONAL SEARCH REPORT

International application No.

PCT/US 08/88665

A. CLASSIFICATION OF SUBJECT MATTER

IPC(8) - G01N 29/02 (2009.01)

USPC - 73/23.27

According to International Patent Classification (IPC) or to both national classification and IPC

B. FIELDS SEARCHED

Minimum documentation searched (classification system followed by classification symbols)

IPC(8): G01N 29/02 (2009.01)

USPC: 73/23.27

Documentation searched other than minimum documentation to the extent that such documents are included in the fields searched

IPC(8): G01N 29/02 (2009.01) - see search terms below

USPC: 73/23.27, 23.42; 95/15; 137/12 - see search terms below

Electronic data base consulted during the international search (name of data base and, where practicable, search terms used)

PubWEST(USPT,PGPB,EPAB,JPAB); DialogPRO(Engineering); GoogleScholar

Search Terms: Reagent, syringe, sample, rotary, valve, detector, coil, reaction, mixing, loop, holding, isolation, constant, flow, pressure, controller, pump, syringe, compensate, transport, medium, carrier, voltage, orifice, distillation, dialysis

C. DOCUMENTS CONSIDERED TO BE RELEVANT

Category*	Citation of document, with indication, where appropriate, of the relevant passages	Relevant to claim No.
X	US 6,887,429 B1 (MARSHALL et al.) 03 May 2005 (03.05.2005), entire document especially Fig 1, 6, 9, col 5, ln 66 - col 6, ln 5, col 6, ln 40-41, col 6, ln 47-49, col 8, ln 38-39, col 9, ln 25-29, col 9, ln 38-40, col 9, ln 44-46, col 9, ln 54-56, col 9, ln 59-63	1-3, 6-12, and 14
Y		4-5, 13, 16-17, 19-20, 24-25, 37-53, 55-59, 67, 72-76, 78-79, and 82-83
Y	US 2004/0163706 A1 (VOLGYESI) 26 August 2004 (26.08.2004), Fig 1-4, para [0081], [0082]	4-5, 22-23, 28-33, 42-43, 62-65, 69-71, and 77
Y	US 5,180,487 A (SAITO et al.) 19 January 1993 (19.01.1993), Fig 1, col 2, ln 40-46, col 4, ln 18-24	15-18 and 19-85
Y	US 3,398,689 A (ALLINGTON) 27 August 1968 (27.08.1968), Claim 1	13, 15-51, 54-85
Y	US 6,341,520 B1 (SATO et al.) 29 January 2002 (29.01.2002), Fig 1, col 6, ln 20-35	18, 26-30, 32-36, 44-51, and 80-85
Y	US 5,695,720 A (WADE et al.) 09 December 1997 (09.12.1997), Fig 2	51 and 85

 Further documents are listed in the continuation of Box C.

* Special categories of cited documents:

"A" document defining the general state of the art which is not considered to be of particular relevance

"E" earlier application or patent but published on or after the international filing date

"L" document which may throw doubts on priority claim(s) or which is cited to establish the publication date of another citation or other special reason (as specified)

"O" document referring to an oral disclosure, use, exhibition or other means

"P" document published prior to the international filing date but later than the priority date claimed

"T" later document published after the international filing date or priority date and not in conflict with the application but cited to understand the principle or theory underlying the invention

"X" document of particular relevance; the claimed invention cannot be considered novel or cannot be considered to involve an inventive step when the document is taken alone

"Y" document of particular relevance; the claimed invention cannot be considered to involve an inventive step when the document is combined with one or more other such documents, such combination being obvious to a person skilled in the art

"&" document member of the same patent family

Date of the actual completion of the international search

02 February 2009 (02.02.2009)

Date of mailing of the international search report

09 FEB 2009

Name and mailing address of the ISA/US

Mail Stop PCT, Attn: ISA/US, Commissioner for Patents

P.O. Box 1450, Alexandria, Virginia 22313-1450

Facsimile No. 571-273-3201

Authorized officer

Lee W. Young

PCT Helpdesk: 571-272-4300
PCT OSP: 571-272-7774