

(No Model.)

2 Sheets—Sheet 1.

# R. N. INK. ROTARY STEAM ENGINE.

No. 524,763.

Patented Aug. 21, 1894.

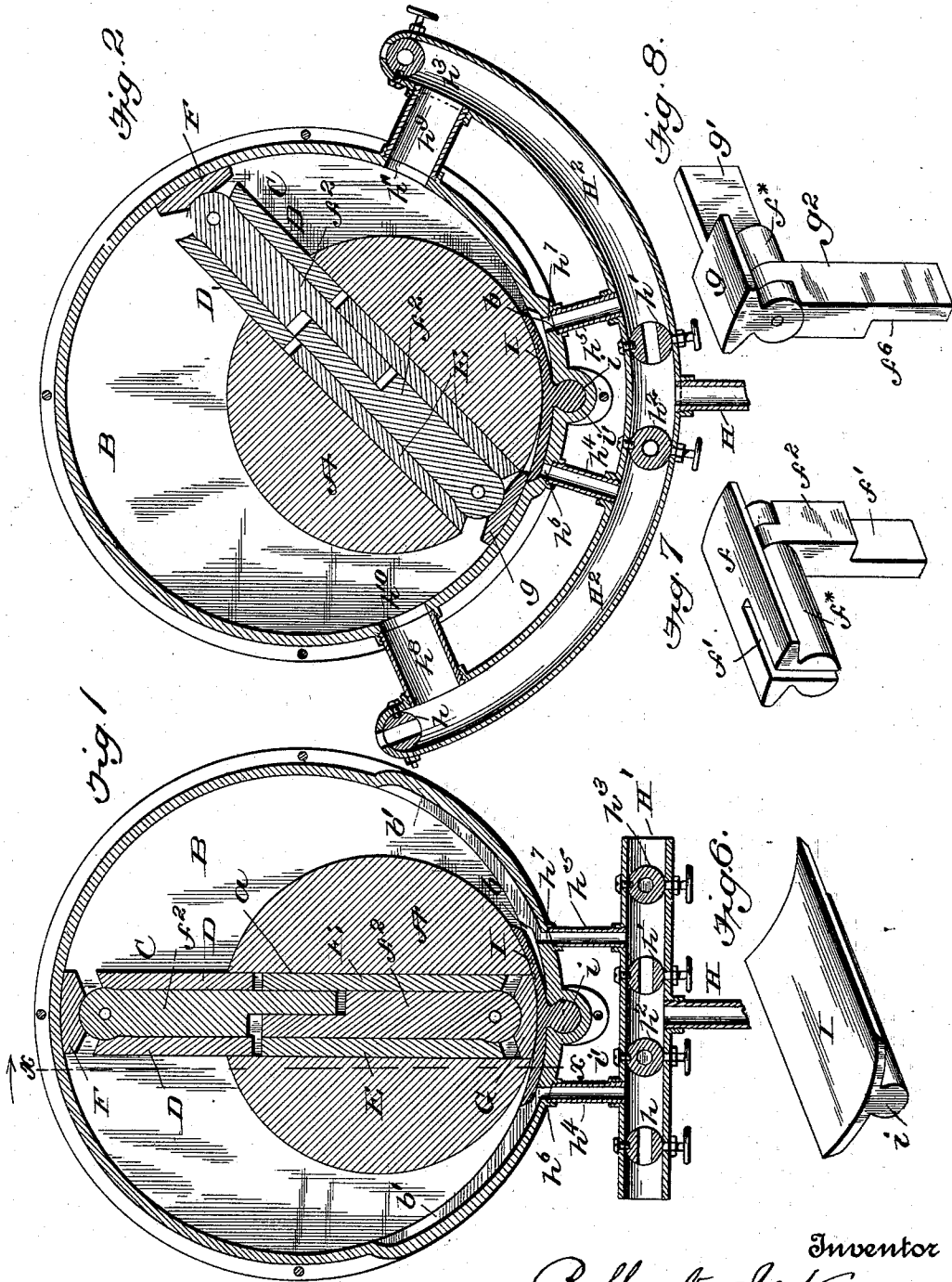

Witnesses  
*J. Albert Johnson,*  
*Richard Hillman*

Inventor  
*Rolla N. Ink,*  
 By *Jana Edga Smith*  
 His Attorney

(No Model.)

2 Sheets—Sheet 2.

# R. N. INK. ROTARY STEAM ENGINE.

No. 524,763.

Patented Aug. 21, 1894.

Fig. 3.

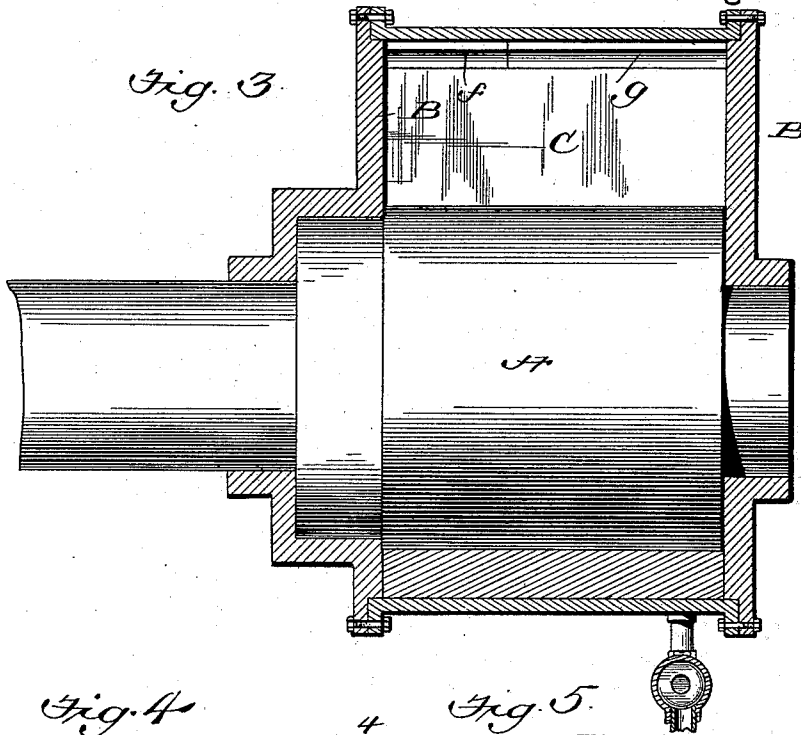

Fig. 4.

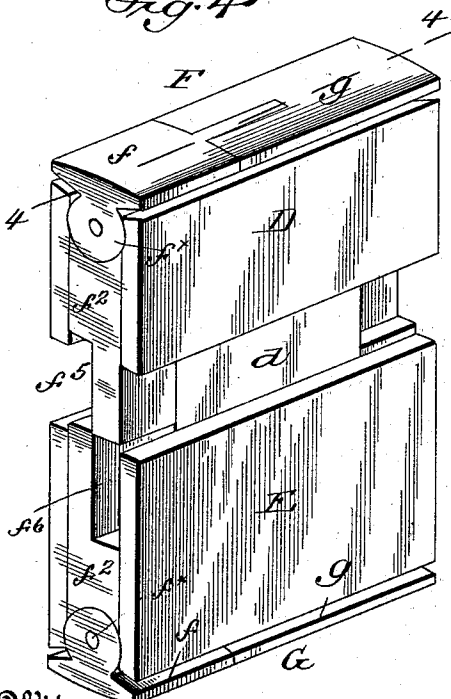
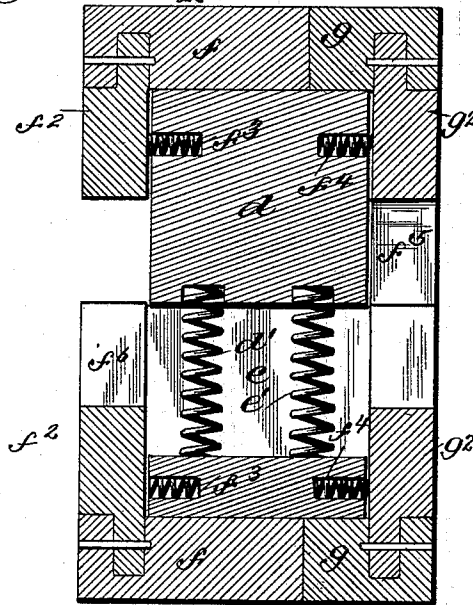

Fig. 5.



Inventor

Rolland Ink.

By James Edgar Smith,  
His Attorney

Witnesses  
Arthur Johnson,  
Ruth Johnson

# UNITED STATES PATENT OFFICE.

ROLLA N. INK, OF MOSELLE, NORTH DAKOTA.

## ROTARY STEAM-ENGINE.

SPECIFICATION forming part of Letters Patent No. 524,763, dated August 21, 1894.

Application filed May 10, 1894. Serial No. 510,740. (No model.)

*To all whom it may concern:*

Be it known that I, ROLLA N. INK, a citizen of the United States, residing at Moselle, in the county of Richland and State of North Dakota, have invented certain new and useful Improvements in Rotary Steam-Engines; and I do hereby declare that the following is a full, clear, and exact description of the invention, which will enable others skilled in the art to which it appertains to use the same.

My invention is an improvement in rotary steam engines, and has for its objects to provide a piston which will fit closely to the inner surfaces of the cylinder at all points and during its entire revolution, forming a steam-tight connection therewith; to provide a piston capable of automatic compensation for the wear of its packing surfaces; to provide a simple and effective valve which, with the piston drum, will form a steam-tight connection, separating the inlet and exhaust sides of the cylinder; to provide a rotary steam engine with ports so arranged that the steam will be supplied to the piston with gradually increasing force and the exhaust steam withdrawn rapidly and completely; and, furthermore, to provide certain details of construction, whereby a rotary engine, simple in construction will be effective in operation and may be rapidly reversed.

With these objects in view, my invention resides in the structure as a whole, in the various details of construction, and in the combinations of the parts, all as hereinafter more particularly described and as pointed out in the claims.

The nature of my invention will more clearly appear from the following description, taken in connection with the drawings, in which—

Figure 1, is a view showing my engine in vertical cross section; Fig. 2, a like view, showing a modified form of construction; Fig. 3, a view, partly in elevation, taken on line  $x-x$  of Fig. 1, and viewed in the direction of the arrow; Fig. 4, a perspective view of the piston, showing the members separated; Fig. 5, a section, taken on the line 4-4 of Fig. 4, and viewed in the direction of the arrow; Fig. 6, a view in perspective of the combined inlet and exhaust valve; and Figs. 7 and 8, are details.

A designates the piston drum or shaft, part of which is within the cylinder B, and located eccentrically with respect thereto. The piston drum has one of its ends flush with one end of the cylinder and extends thence through suitable bearings in the other end of the cylinder, where it may be provided with any suitable power-transmitting mechanism.

C indicates the piston, which is located in a transverse or diametrical slot,  $a$ , in the piston drum, and is adapted to slide therein. This piston comprises two members, D, E; the part D, having a tongue  $d$ , which is adapted to enter a recess,  $e$ , formed in the part E. The two parts D and E are normally pressed apart by means of the springs,  $d' e'$ , which are placed between them. As the piston drum is located eccentrically with respect to the cylinder, and as the piston slides in the transverse slot  $a$ , during the revolution of the piston drum, it is evident that if the two sides of the piston abutting against the interior circular surface of the cylinder be provided with packing in the nature of shoes pivotally connected to the piston, they will adapt themselves to the interior periphery of the cylinder, and always bear flush against the same. To this end, I provide on each side of the piston the pivotal shoes F, G, each of which comprises two members  $f, g$ , the two parts having a tongue and groove connection,  $f', g'$ . The parts D and E have their outer edges grooved to form, in connection with a rounded projection  $f^*$ , on the shoes F and G, a rule-joint. The parts  $f$ , and  $g$ , are pivotally connected, as shown, to tongue-pieces,  $f^2 g^2$ , these tongue-pieces being recessed, respectively, on opposite sides,  $f^5, f^6$ , to allow their ends to pass each other in the adjustment of the parts D and E. The tongue-pieces  $f^2 g^2$  fit in lateral recesses in the ends of the parts D and E, and are flush with, or extend beyond, the ends of the piston. Situated within the parts D and E are springs,  $f^3, f^4$ , which bear against the parts  $f^2, g^2$ , and tend normally to press them laterally apart, forming close connection with the flat interior ends of the cylinder.

It is plain from the construction of the piston, as just described, that the parts D and E, in connection with the springs  $d', e'$ , will adjust themselves to the variations in length

between the diameter of the cylinder and the various chords thereof as the piston revolves within the cylinder; and it is also evident that any wear on either the lateral or terminal faces of the piston will be compensated for by the outward pressure of the two sets of springs,  $d'$ ,  $e'$ , and  $f^3$ ,  $f^4$ , so that steam-tight connection is always maintained between the piston and the cylinder at all points.

H indicates the steam-supply pipe, which leads, in my preferred construction, shown in Fig. 1, into a short, horizontally-disposed pipe, H', which is open at both ends, so that either end may be used as an exit for the exhaust steam, as will presently appear. Situated within the pipe H' are the two sets of valves  $h$ ,  $h'$ ,  $h^2$ ,  $h^3$ . Communication to the cylinder is had through the ports  $h^6$ ,  $h^7$ , through the medium of the branch-pipes  $h^4$ ,  $h^5$ , which connect with the pipe H'.

I, indicates my improved valve which, in connection with the piston drum, separates the inlet from the exhaust side of the cylinder. This valve may be described as approximating the appearance, in cross section, of a crescent, and has projecting from its convex, or lower side, and extending along its entire length, the rounded tongue  $i$ , which is adapted to fit snugly in a cylindrical groove,  $i'$ , in the cylinder casing, and to form therewith a rule-joint. A longitudinal recess,  $b$ , is formed in the lower part of the cylinder, and in this the valve I is seated, extending the entire length of the cylinder, its two ends being flush, respectively, with the two ends of the cylinder. The curve of the valve I is greater than that of the cylinder, and it is thus caused to be rocked in its seat by the passage over it of the shoes F and G. It extends slightly beyond the ports  $h^6$ ,  $h^7$ , whereby, when one port is used as the inlet, the side of the valve I above it is elevated by the impact of the steam, and the opposite side of the valve is thereby depressed over the other port or exhaust. This arrangement enables the piston to pass over the depressed side of the valve. After the piston has gone beyond the pivotal line of the valve I, it bears the valve down over the inlet port until the piston has passed beyond it, thus opening wide the exhaust port. It will be seen that one side of the valve I is always kept close to the piston, and piston-drum, forming with one or the other a steam-tight connection at all times, and thereby separating the inlet side from the exhaust side of the cylinder.

Connecting with the ports  $h^6$ ,  $h^7$ , and opening from said ports into the cylinder, I provide grooves  $b'$ ,  $b'$ , in the interior of the cylinder. The purpose of these grooves is to keep the inlet and exhaust ports always partly open and thus to facilitate the ready access of the steam to the piston, and in larger and larger quantities as the piston moves beyond the inlet port, and also to permit the ready and complete exhaust of the steam.

From what has already been said it will be

seen that when the valves  $h$ ,  $h'$ , are open, and the valves  $h^2$ ,  $h^3$  closed, steam enters from the supply-pipe H and passes through the valve  $h'$ , branch-pipe  $h^5$  and port  $h^7$  to the cylinder, thereby, by its pressure, causing the valve I to rock to open wide port  $h^7$  and partly to close port  $h^6$ . The pressure of the steam on the piston causes a revolution of the piston-drum, the piston-members being pressed apart by the springs  $d'$ ,  $e'$ , follow the contour of the periphery of the cylinder closely, and the piston itself slides back and forth in the slot  $a$  in the piston-drum, the shoes F and G by reason of their pivotal connection with the piston, always bearing flush against the interior of the cylinder. As the piston revolves, the passage of each shoe over the valve I will rock the same partly to close port  $h^7$  and to open wide port  $h^6$ , whereby the exhaust may escape more easily through said port to pipe  $h^4$  and thence through the valve  $h$  to the air. As soon as the shoe passes from the valve, the force of the steam will again open it, when the preceding operation will be repeated. In order to reverse the engine, it is only necessary to close the valves  $h$ ,  $h'$  and open the valves  $h^2$ ,  $h^3$ .

In Fig. 2 I have shown a modification. In this construction a curved pipe, H<sup>2</sup>, extending a considerable distance up on each side of the cylinder, is used instead of the short pipe H'. Near the ends of the pipe H<sup>2</sup> branch-pipes  $h^8$ ,  $h^9$  connect with ports  $h^{10}$ ,  $h^{11}$  in the cylinder. These ports form additional means for the entrance and exhaust of the steam. The entrance and exhaust of the steam is regulated by the valves  $h$ ,  $h'$ ,  $h^2$ ,  $h^3$ , as in the previous construction, and the operation is in all respects the same, except that the steam enters through both port  $h^7$  and port  $h^{11}$  and exhausts through both ports  $h^{10}$  and  $h^6$ . The engine may be reversed in the same manner as previously described with reference to Fig. 1. It is to be noted in connection with this form of my invention that the elements are practically the same as in the form first described, for the curved pipe and the ports  $h^{10}$  and  $h^{11}$  merely take the place of the grooves  $b'$ ,  $b'$ , in the preferred construction.

Having thus fully described my invention, what I claim as new, and desire to secure by Letters Patent, is—

1. In a rotary engine, a cylinder, a piston-drum located therein having a slot, a piston adapted to slide in said slot, shoes, formed in two parts having a tongue and groove connection, pivotally secured to said piston, means, such as springs, for normally pressing the two members of the shoe apart, substantially as described.

2. In a rotary engine, a cylinder, a piston-drum located eccentrically therein having a slot, a piston formed in two parts adapted to slide in said slot, means, such as springs, located between the two members of the piston and adapted normally to press them apart,

shoes pivotally secured to said piston, the said shoes being in two parts having a tongue and groove connection, and means, such as springs, pressing the two members of the shoes apart, substantially as and for the purpose described.

3. In a rotary engine, a cylinder, a piston-drum located eccentrically therein having a slot, a piston adapted to slide in the slot, said piston comprising the parts D and E having a tongue and groove connection and pieces *f*, *g*, having a tongue and groove connection with each other and a rule-joint connection with the piston, tongue-pieces *f*<sup>2</sup>, *g*<sup>2</sup> pivoted to the pieces *f*, *g*, respectively, and springs within said piston bearing on said parts D and E and *f*, *g*, respectively, and tending normally to press them apart, substantially as described.

4. In a rotary steam engine, a cylinder, a piston-drum located therein having a diametrical slot, a piston, sliding in said slot, inlet and exhaust ports, a crescent-shaped valve, controlling the ports, within said cylinder and having a pivotal connection therewith, and adapted to be rocked by the piston in its revolutions, said valve having one of its sides normally bearing against the piston-drum, whereby a steam-tight connection is always maintained between said side and the piston-drum and piston, substantially as described.

5. In a rotary engine, a cylinder, a piston-drum located eccentrically therein having a slot, a piston adapted to slide in said slot, inlet and exhaust ports, and a crescent-shaped valve, controlling said ports, having a pivotal connection with the cylinder and adapted to be rocked by the piston in its revolutions, substantially as described.

6. In a rotary engine, a cylinder, a piston-drum located therein carrying a piston, inlet and exhaust ports, a valve, controlling said ports, within the cylinder and having a pivotal connection therewith, said valve being adapted to be rocked by the piston in its revolutions to open the exhaust and partially to close the inlet port simultaneously, substantially as and for the purpose set forth.

7. In a rotary steam engine, in combination with the cylinder, piston, and piston-drum, a recess in said cylinder, an inlet and an exhaust port located in said recess, said inlet port connected with a suitable steam-supply, and a crescent-shaped valve, controlling said ports, seated in the recess, and adapted to be rocked by the piston in its revolutions to open the exhaust and partially to close the inlet port simultaneously, substantially as described.

8. In a rotary engine, in combination with the cylinder, piston, and piston-drum, a recess in said cylinder, a circular groove communicating with said recess, combined inlet and exhaust ports located in said recess and connected with a suitable steam-supply, and a crescent-shaped valve, controlling said ports, seated in said recess and having a rounded projection on its convex side adapted to fit snugly in said circular groove, said valve having a curvature greater than that of the cylinder, whereby one of its ends is always in the path of the piston and adapted to be rocked partially to close a port when the piston passes over it and to be rocked by the pressure of the steam to open said port when the piston has passed from it, substantially as described.

9. In a rotary steam engine, in combination with a cylinder, piston and piston-drum, combined inlet and exhaust ports in said cylinder, a valve controlling said ports, a pipe containing two sets of valves communicating with said ports by means of branch pipes and a steam-supply connected with said pipe.

10. In a rotary steam engine, in combination with a cylinder, piston and piston-drum, combined inlet and exhaust ports, *h*<sup>6</sup>, *h*<sup>7</sup>, *h*<sup>8</sup>, *h*<sup>9</sup>, in said cylinder, a valve controlling the ports *h*<sup>6</sup>, *h*<sup>7</sup>, branch-pipes connecting the inlet and exhaust ports with a semi-circular pipe *H*<sup>2</sup> having two sets of valves therein, and a steam-supply connected with said pipe, substantially as described.

ROLLA N. INK.

Witnesses:

B. L. BOGOST,  
ALTA M. INK.