

W. F. WITTICH.
 STONE CUTTING TOOL.
 APPLICATION FILED JUNE 4, 1908.

972,969.

Patented Oct. 18, 1910.

3 SHEETS-SHEET 1.

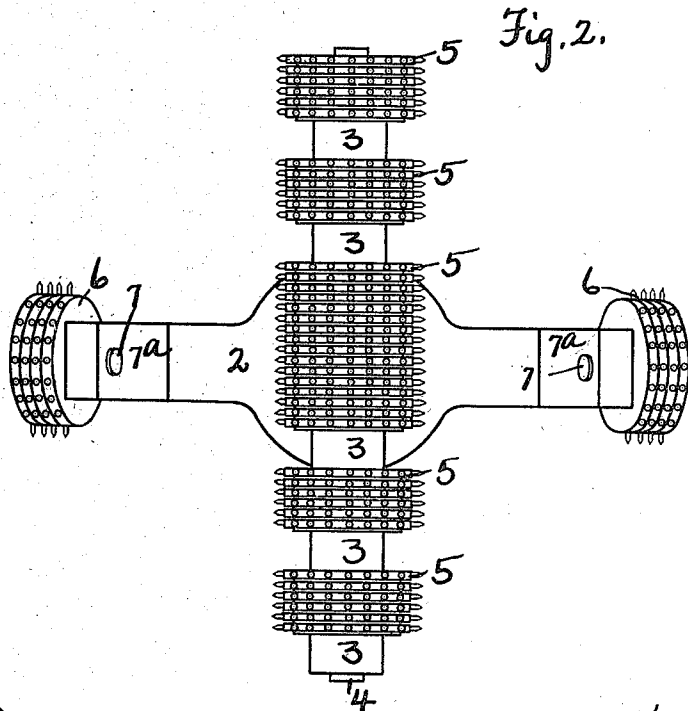
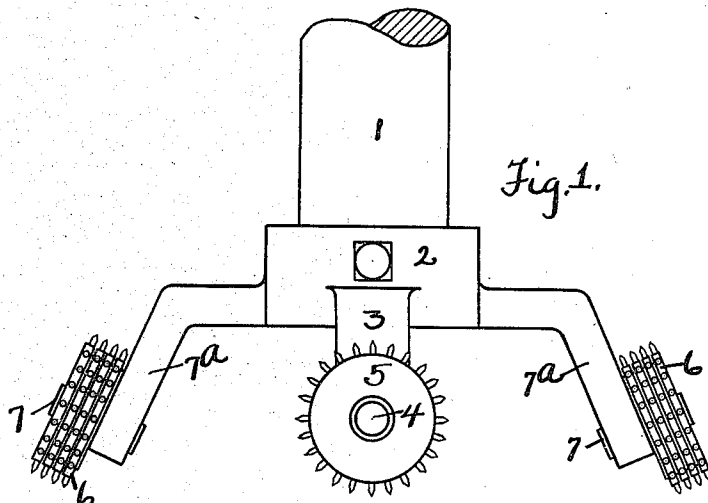

Witnesses
J. P. Kane
R. S. Lord

Inventor,
William F. Wittich
 by *A. C. Lord*
 Attorney

W. F. WITTICH.
 STONE CUTTING TOOL.
 APPLICATION FILED JUNE 4, 1908.

972,969.

Patented Oct. 18, 1910.

3 SHEETS—SHEET 2.

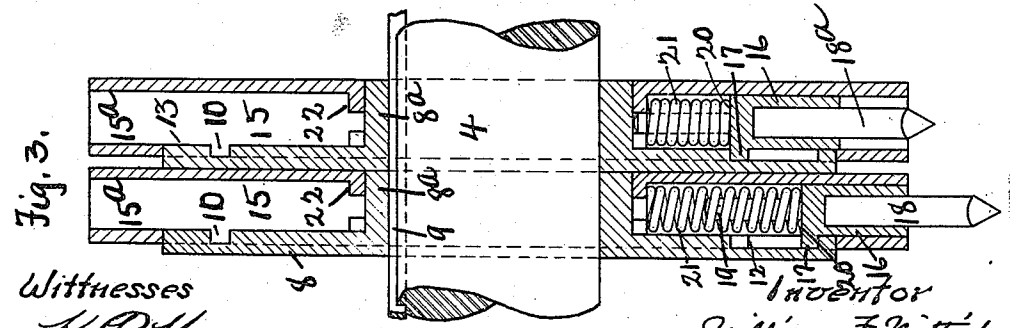
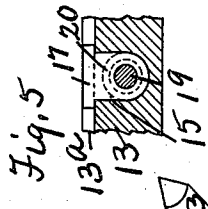
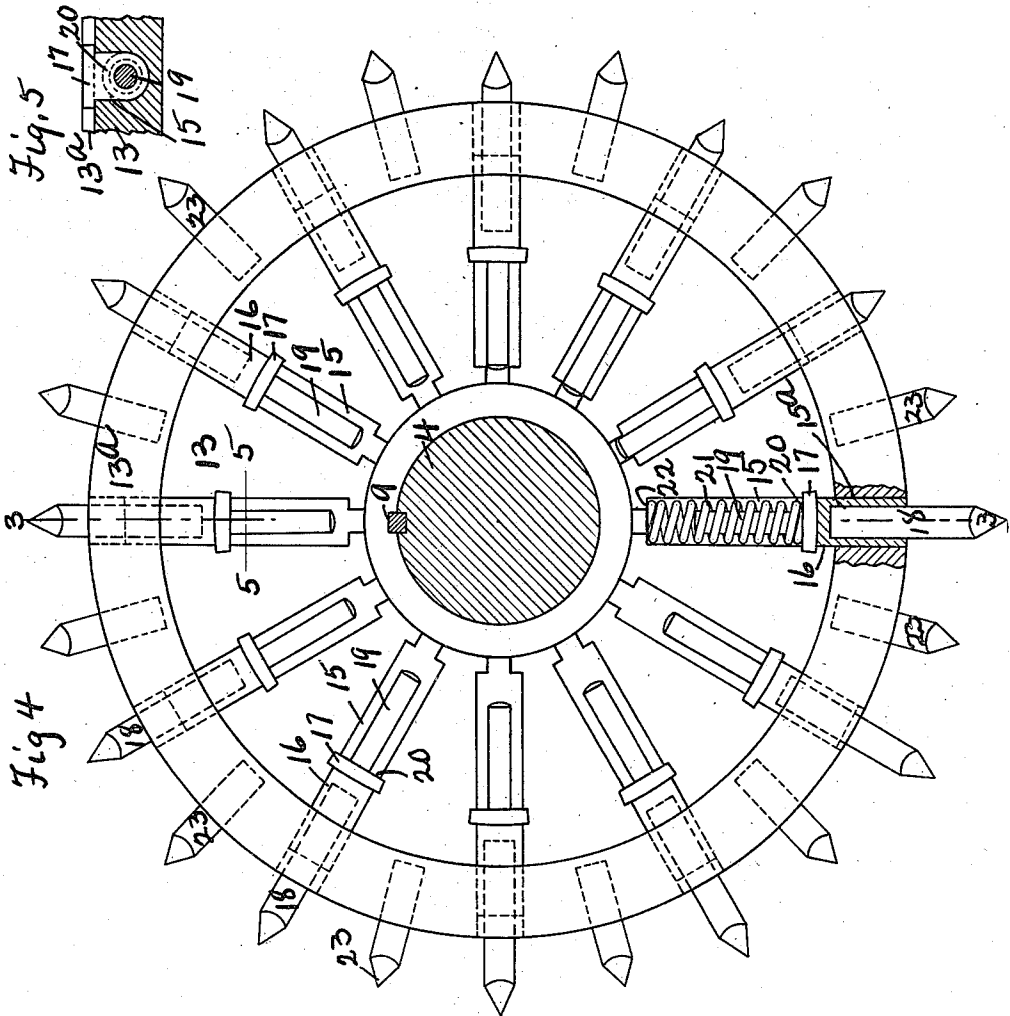

Fig. 3.

Witnesses
K. R. Kane
R. S. Lord

Inventor
William F. Wittich
 By *N. Z. Lord*
 Atty.

W. F. WITTICH.
STONE CUTTING TOOL.
APPLICATION FILED JUNE 4, 1908.

972,969.

Patented Oct. 18, 1910.

3 SHEETS—SHEET 3.

Fig. 6.

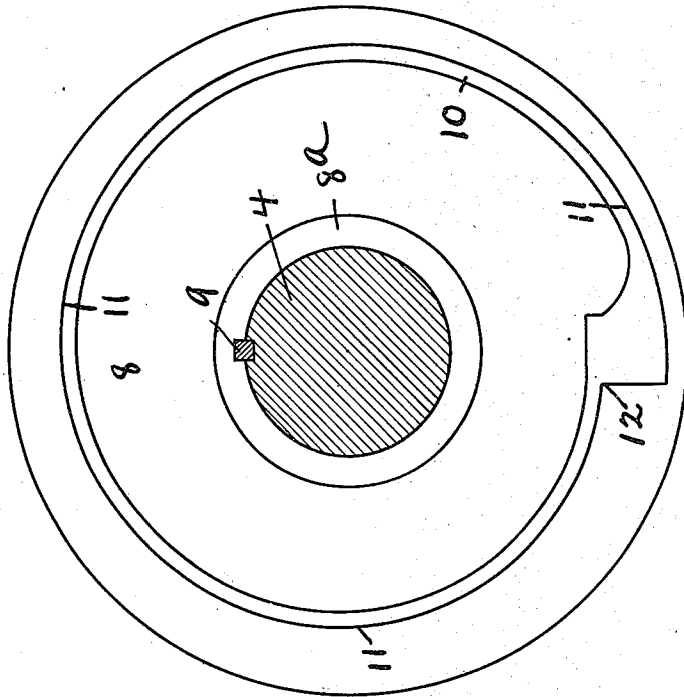

Witnesses
K. R. James
R. S. Lord

Inventor
William F. Wittich
By *W. Z. Lind*
Attorney

UNITED STATES PATENT OFFICE.

WILLIAM F. WITTICH, OF ERIE, PENNSYLVANIA, ASSIGNOR TO THE WITTICH SUCCESS
SHAFT SINKING AND TUNNELLING MACHINE COMPANY, OF ERIE, PENNSYLVANIA,
A CORPORATION OF ARIZONA TERRITORY.

STONE-CUTTING TOOL.

972,969.

Specification of Letters Patent.

Patented Oct. 18, 1910.

Application filed June 4, 1908. Serial No. 436,613.

To all whom it may concern:

Be it known that I, WILLIAM F. WITTICH, a citizen of the United States, residing at Erie, in the county of Erie and State of Pennsylvania, have invented new and useful Improvements in Stone-Cutting Tools, of which the following is a specification.

This invention relates to stone cutting tools, and consists in certain improvements in the construction thereof as will be hereinafter fully described and pointed out in the claims.

In a general way, the invention consists in mounting rotating carriers on cutting heads, and arranging cutting points on the carriers, these cutting points being brought into action by the rotation of the carrier. In the present invention the cutting points are advanced and retracted from the work. In the preferred construction the points are violently advanced by a spring, so as to effect its full action on the face being operated on, and these points are retracted preferably by the rotation of the carrier, and by the traction of the carrier on the face. In this way a rotative cutter is rendered much more effective, especially with certain kinds of rock formation where a blow will create a fracture, so that the cutting is effected by the removal of chips.

The invention is illustrated in the accompanying drawings as follows: Figure 1 shows a side elevation of a cutter head. Fig. 2 a bottom view of the cutter head. Fig. 3 a section on the line 3-3 in Fig. 4, the view being from the right of Fig. 4. Fig. 4 a side elevation partly in section of the carrier, the cam plate being removed. Fig. 5 a section on the line 5-5 in Fig. 4. Fig. 6 a side elevation of the cam plate, the view being from the right of Fig. 3.

1 marks the driving shaft; 2 the cutter head; 3 the shaft supports on the head; 4 a shaft carrying a line of cutter wheels, the shaft being fixed in the supports 3; 5 a series of cutters mounted on the shaft 4; 6 a series of inclined cutters having the widest sweep for operating on the outer edges of the cut; 7 a shaft on which these cutters are mounted, the shaft being mounted on the arm 7^a and fixed therein. All of these cutters are of similar construction.

The cam plates 8 are fixed on the shaft 4 by the key 9, the hubs of the plates abutting

as clearly shown in Fig. 3. Carriers 13 are journaled on the hubs 8^a and operate between the plates 8. These carriers have slots 15 arranged in one face and an overhanging rim 13^a which extends over the cam plate 8. The slots 15 pass through this rim and form the perforations 15^a. These slots form guide ways for point holders 16, the point holders being slidingly mounted in the slots and extending into the perforations 15^a. Each holder has a projection or lug 17 which extends into the cam slot 10. Each holder has a point mounted in its outer end. A pin 19 projects from its inner end forming a shoulder 20 at the connection between the pin and the holder 16. A coiled spring 21 is arranged around the pin 19 and tensioned between the shoulder 20 and the shoulder 22 at the end of the slot nearest the center of the carrier.

The cam slot 10 has a cam surface which as the carrier 13 is rotated crowds the lug 17 inwardly toward the center of the carrier, so that the point is brought to the position shown by point 18^a in Fig. 3. The cam plate is so positioned on the shaft 4 that the point is fully retracted just as it is brought opposite the face being cut. At this point it reaches a step 12 where it passes off of the surface 11, and is forced outwardly or advanced by the spring 21, so as to deliver a blow on the face being cut.

The carrier 13 is rotated by traction as the shaft 4 progresses. To assist in this movement a series of stationary points 23 are mounted in the carrier 13.

It will be noted that this construction permits of a series of carriers 13 being arranged in close proximity to each other along a common shaft. I prefer that the shaft 4 be advanced rotatively as shown, as this forms a convenient means for driving, and also makes a uniform tunnel or shaft.

What I claim as new is:

1. In a stone cutting tool, the combination of a rotary carrier; a cutter point thereon; a head carrying the carrier, the carrier being adapted to be rotated by traction as the carrier is advanced over a face being cut; and means for automatically retracting and advancing abruptly the cutter point as the carrier is rotated.

2. In a stone cutting tool, the combination of a shaft; a cam plate fixed on the shaft

having swells extending in a radial direction from the shaft; a carrier rotatively mounted with relation to the cam plate of said shaft; a cutting point mounted on the carrier; and means connected with the point for engaging the cam plate for automatically actuating the point as the carrier is rotated.

3. In a stone cutting tool, the combination of a shaft 4; a cam plate fixed thereon, having a hub extending laterally therefrom; a carrier wheel 13 rotatively mounted on the hub, and having guide slots in the face thereof; point holders slidably mounted in the slots; points on the holders; lugs on the holders engaging the cam plate for retracting the holders and points; and springs arranged in the sockets and tensioned against the holder and the socket for advancing the points as the carrier is rotated.

4. In a stone cutting tool, the combination of a rotary head; a rotary carrier mounted on the head, the axis of the carrier being radial to the axis of the head; a point mounted radially in the carrier; and means for automatically advancing and retracting the point as the carrier is rotated.

5. In a stone cutting tool, the combination of a rotary head; a rotary carrier mounted on the head and arranged to be rotated by traction as the head is rotated; a point mounted on the carrier; and means for automatically advancing and retracting the point as the carrier is rotated.

6. In a stone cutting tool, the combination of a rotary head; a shaft carried by the head, the axis of the shaft being radial to the axis of the head; a cam plate fixed on the shaft; a carrier mounted to rotate about the shaft;

a point carried by the carrier; and means connected with the point and engaging the plate for actuating the point as the carrier is rotated.

7. In a stone cutting tool, the combination of a shaft; a series of cam plates fixed on the shaft having swells extending in a radial direction; a corresponding series of carriers mounted between said plates, and bent to rotate about said shaft; points on said carriers; and means connected with said points and engaged by said plates for automatically actuating said points, the points on each carrier being operated independently.

8. In a stone cutting tool, the combination of a shaft; a series of cam plates mounted on the shaft, each plate having a hub; corresponding carrier wheels rotatively mounted in the hubs between the plates; points slidably mounted in the wheels; and means connected with the points and engaging the cam plates for automatically actuating the points on one carrier independently of any other carrier.

9. In a stone cutting tool, the combination of a rotary head; a plurality of points carried by the head, arranged to operate in the general direction of the axis of the head; and a rotating driving means having its axis radial to the axis of the head for actuating said points.

In testimony whereof I have hereunto set my hand in the presence of two subscribing witnesses.

WILLIAM F. WITTICH.

Witnesses:

K. R. KANE,
R. S. LORD.