

C. Moore,

Meter.

No. 111,134.

Patented Jan. 24. 1871.

Fig. 1.

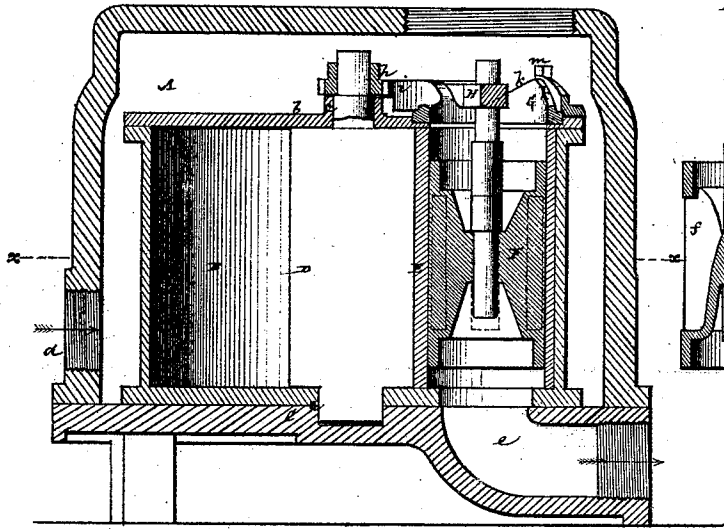

Fig. 5.

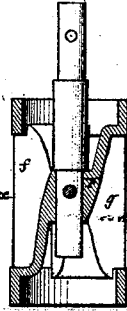

Fig. 4.

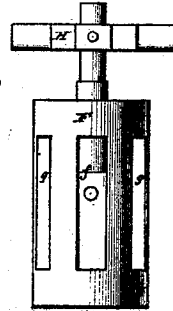

Fig. 2.

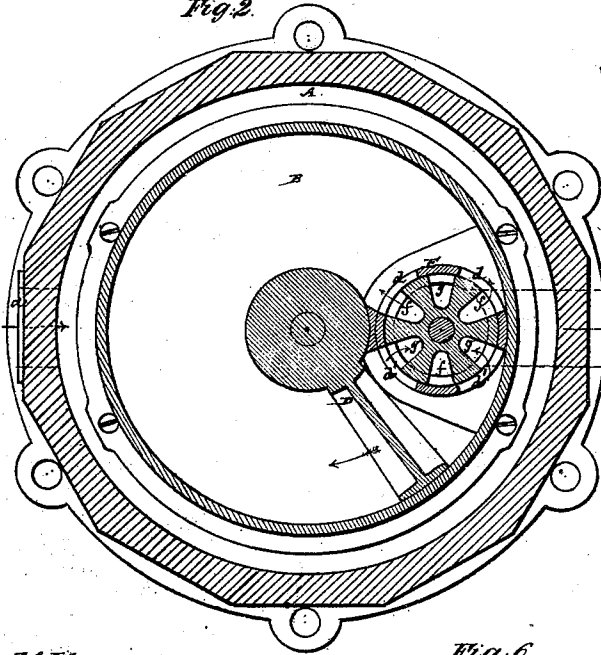
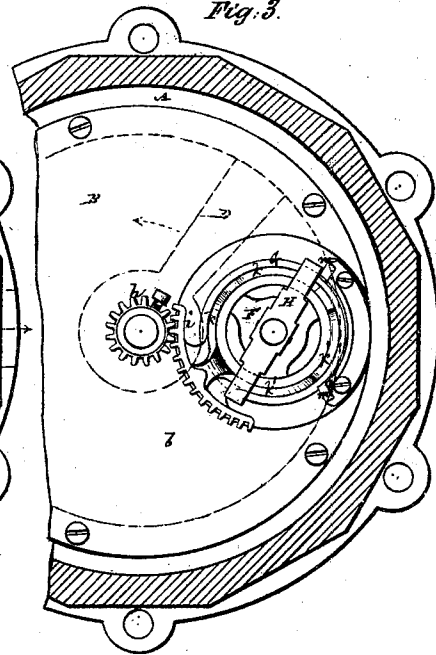
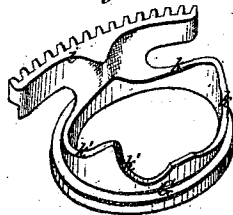

Fig. 3.



Witnesses:
Wm. Haynes
Wm. H. K.

Fig. 6.



Charles Moore

UNITED STATES PATENT OFFICE.

CHARLES MOORE, OF NEW YORK, N. Y., ASSIGNOR TO JOSÉ F. DE NAVARRO,
OF SAME PLACE.

IMPROVEMENT IN METERS.

Specification forming part of Letters Patent No. **111,134**, dated January 24, 1871.

To all whom it may concern:

Be it known that I, CHARLES MOORE, of the city, county, and State of New York, have invented a new and useful Improvement in Liquid-Meters, of which the following is a full, clear, and exact description, reference being had to the accompanying drawing, forming part of this specification, and in which—

Figure 1 represents a vertical section of a liquid-meter constructed in accordance with my improvement; Fig. 2, a horizontal section through the line *x x* in Fig. 1; and Fig. 3, a plan, in part, with the outer case in section. Figs. 4 and 5 represent a longitudinal exterior view and longitudinal section of the valve detached, and Fig. 6 a view, in perspective, of a vibrating cam by which the valve is operated.

Similar letters of reference indicate corresponding parts.

My improvement in liquid-meters is more particularly designed for the measuring of water, and will here be described accordingly. It relates to single piston meters, and is especially applicable to that description of meters in which a swinging piston or diaphragm, hung to vibrate about a vertical axis, is used.

The invention consists in a novel construction of the valve, and means of operating the same, including a particular arrangement of the passages controlled by the valve, whereby a free supply and discharge is kept up without interruption of the stream, and the valve is rapidly reversed, in part by the action of its weight, and in part by the pressure of the inlet-water on it.

Referring to the accompanying drawing, A represents an outer chamber or case, to which the water is admitted, as by an inlet, *a*, or otherwise, and which may be provided with an opening in its top for communicating motion from the working portions of the meter to the registering mechanism above, and that it is not necessary here to describe as the same forms no part of this invention. B is the measuring cylinder or chamber of the meter, arranged to occupy a vertical position on a base-plate, C, within the chamber A, and covered by a lid, *b*. D is the swinging diaphragm or piston, disposed to occupy a vertical position within the cylinder B, and turning in its reciprocating movement toward and from op-

posite sides of an abutment, E, on upper and lower pivots, or within bearings *c c*, arranged to occupy a concentric position, relatively with the cylinder. The abutment E is made hollow, and of cylindrical configuration, to receive down within it the valve F, that operates therein with a vibratory motion, as about a vertical axis, and in an up-and-down direction, as hereinafter described. Said abutment is provided with double vertically-disposed ports *d* and *d'* on opposite sides of it, through which the water is alternately admitted to, and passed off from, the cylinder by the operation of the valve, to keep up the reciprocating or swinging action of the piston. The valve F is formed of a cylinder, open at its opposite ends, through the upper one of which the water is admitted from the case A, while the lower end is in open communication with the exhaust pipe or passage *e* of the meter. In open connection with said ends of the valve are a series of alternately-disposed vertical inlets, *f*, and outlets *g*, made in the sides and body of the valve. These inlet and outlet passages are arranged to occupy equal divisions or spaces, or thereabout, around the valve, and are in number—that is, collectively—half as many again as the ports *d d'* in the abutment, which ports they are preferably made to exceed in length, to provide for the up-and-down movement of the valve, but are of only about half, or a little more than one-half, of the width of said ports, and the metal between such openings *f* and *g* of a like proportion.

The number, arrangement, and proportion of these several ports and passages may be different from the description here given of or for them, but it is preferred to construct and arrange them as specified.

The vibratory motion of the valve alternately opens the ports *d d'* on opposite sides of the abutment to the inlet and outlet ends of the valve, and, by the arrangement of the passages and ports as described, a free ingress and egress for the water through the double ports *d d'* is established at all times, so that there is no dead point or period, as regards the flow of the water into or out of the cylinder, and while the valve is being reversed, which is only momentary, a supply to the ex-

haust is kept up through the ports on both sides of the abutment, which prevents any intermission of the stream; also a full pressure of the inlet-water is brought to bear on the valve to suddenly drop or lower it after it has been raised, which motions are connected with the reversal of the valve, that is vibrated in part by its own weight, and in part by the pressure of the water operating to drop it, as follows: On the upper pivot or spindle of the swinging diaphragm D is a pinion, *h*, arranged to gear with a toothed sector, *i*, that forms a lateral projection from a hollow cam, G, which allows of the passage of the water through it to the valve, and is arranged so as to turn independently of the valve, over which it is concentrically disposed, and forms an open eye, as it were, to the moving sector. This cam is constructed with reversely-disposed inclines K K and K' K' on opposite sides of it, and that serve, as the cam is vibrated by the action of the pinion *h* on the sector *i* in or during the motion of the piston D, to lift the valve by means of a cross bar or piece, H, attached to the valve-spindle, and resting on opposite sides of the cam G. The highest elevation of the valve takes place as the piston D approaches the end of its stroke, after which the slightest continuation in the vibratory motion of the cam G leaves the valve F at liberty to drop, by its bar H, down either two of the opposite inclines K K', according to the direction in which the cam is being vibrated. This reverses in a sudden or rapid manner the valve, which in its drop has its turning motion, as produced by the inclines of the cam, limited or controlled by the bar H striking one or other of two stops, *m m'*, that also serve, in conjunction with one or other of the inclines K K', to keep the valve to its turned position during the reverse movement of the

cam. Said valve drops when released from lift by the action of the cam to effect the turning or reversal of it, as described, in part by its own weight, and in part by the inlet-water rushing down through and pressing on it, and which effectually prevents any possibility of the valve sticking in its raised position, and accelerates its descent and reversal.

What is here claimed, and desired to be secured by Letters Patent, is—

1. The combination, with the swinging or reciprocating piston of the meter, of a valve for controlling the movement of the piston, arranged so that while said valve is lifted by the piston it is free to drop and turn in part by its own weight, and in part by the pressure of the incoming fluid, to effect its reversal at the close of the piston's stroke, substantially as specified.

2. The cylindrical valve F, constructed with open ends and with alternately-disposed inlets *f* and outlets *g*, for operation in relation to the ports *d d'* and inlet and outlet passages or chambers of the meter, essentially as herein set forth.

3. The combination, with the valve F, constructed to operate substantially as described, of the vibrating hollow cam G, with its reversed inclines K K' set in motion by the piston, the cross bar or piece H, and the stops *m m'*, substantially as specified.

4. The combination of the pinion *h* on the piston-shaft, the toothed sector *i*, the hollow cam G, with its reversed inclines K K', the valve F, the cross bar or piece H, and the stops *m m'*, essentially as shown and described.

CHARLES MOORE.

Witnesses:

FRED. HAYNES,
W. J. TUSKA.