

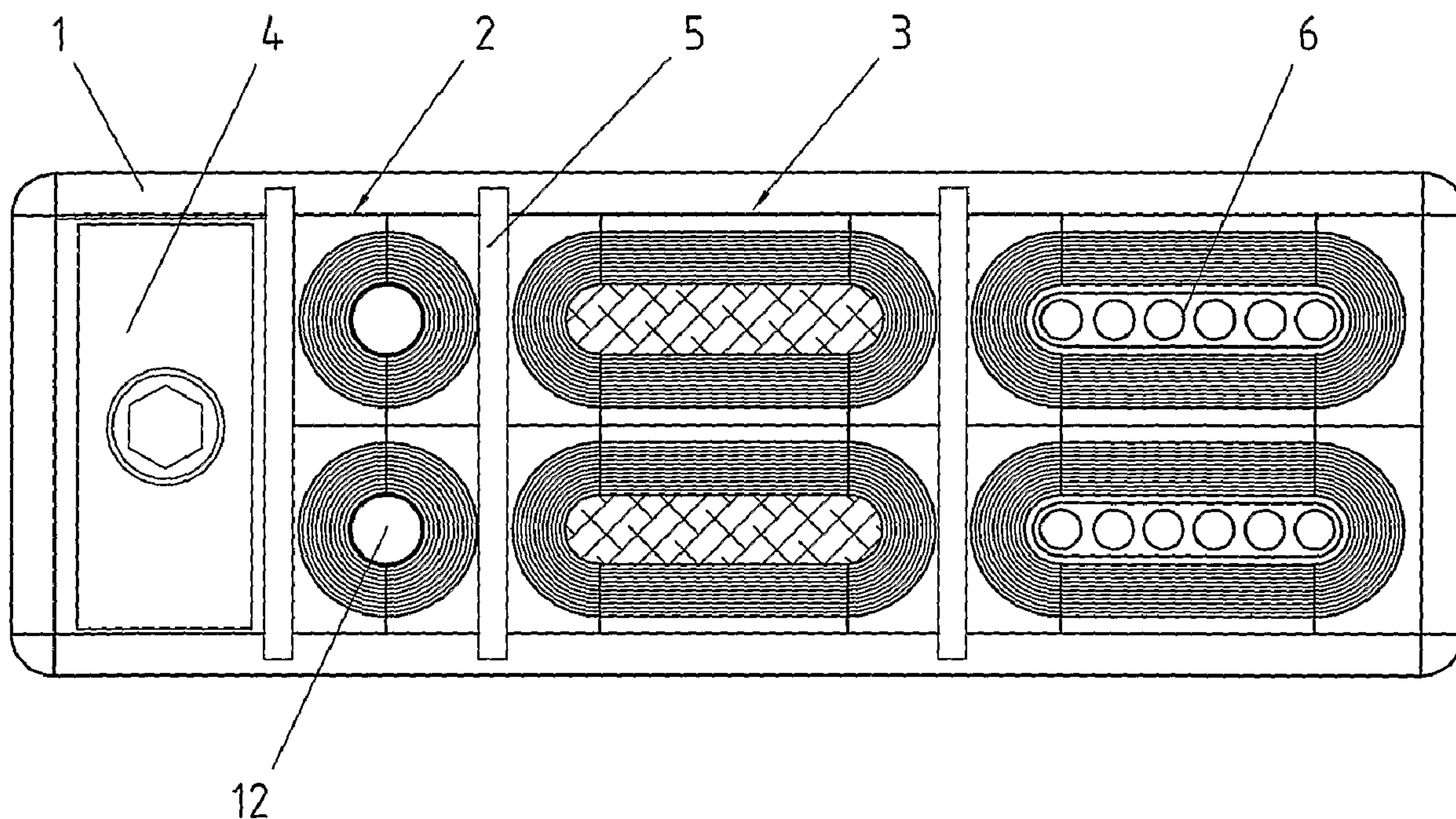

(86) Date de dépôt PCT/PCT Filing Date: 2004/06/14
 (87) Date publication PCT/PCT Publication Date: 2004/12/23
 (45) Date de délivrance/Issue Date: 2010/05/11
 (85) Entrée phase nationale/National Entry: 2005/12/16
 (86) N° demande PCT/PCT Application No.: SE 2004/000925
 (87) N° publication PCT/PCT Publication No.: 2004/112211
 (30) Priorité/Priority: 2003/06/17 (SE0301750-6)

(51) Cl.Int./Int.Cl. *H02G 3/22* (2006.01),
F16L 5/08 (2006.01)
 (72) Inventeur/Inventor:
KREUTZ, TOMAS, SE
 (73) Propriétaire/Owner:
ROXTEC AB, SE
 (74) Agent: MARKS & CLERK

(54) Titre : **MODULE ET CADRES POUR ENTREES DE CABLES**
 (54) Title: **MODULE AND FRAME FOR CABLE ENTRIES**



(57) **Abrégé/Abstract:**

The present invention concerns a module (3) and a frame (1) for cable entries, pipe penetrations etc. The module (3) has end parts (7) and middle parts (8) adaptable to receive flat cables (6) or the like having an elongated cross section. The end parts (7) may be identical to parts forming a module (2) for receiving cables, pipes etc. having a circular cross section. The frame (1) is to receive one or more of said module (3).

(12) INTERNATIONAL APPLICATION PUBLISHED UNDER THE PATENT COOPERATION TREATY (PCT)

(19) World Intellectual Property
Organization
International Bureau



(43) International Publication Date
23 December 2004 (23.12.2004)

PCT

(10) International Publication Number
WO 2004/112211 A1

- (51) International Patent Classification⁷: **H02G 3/22**, F16L 5/08
- (21) International Application Number: PCT/SE2004/000925
- (22) International Filing Date: 14 June 2004 (14.06.2004)
- (25) Filing Language: English
- (26) Publication Language: English
- (30) Priority Data: 0301750-6 17 June 2003 (17.06.2003) SE
- (71) Applicant (for all designated States except US): **ROXTEC AB** [SE/SE]; Box 540, S-371 23 Karlskrona (SE).
- (72) Inventor; and
(75) Inventor/Applicant (for US only): **KREUTZ, Tomas** [SE/SE]; Ringövägen 89, S-371 60 Lyckeby (SE).
- (74) Agent: **STRÖM & GULLIKSON IPC AB**; P.O. Box 4188, S-203 13 Malmö (SE).
- (81) Designated States (unless otherwise indicated, for every kind of national protection available): AE, AG, AL, AM, AT, AU, AZ, BA, BB, BG, BR, BW, BY, BZ, CA, CH, CN, CO, CR, CU, CZ, DE, DK, DM, DZ, EC, EE, EG, ES, FI, GB, GD, GE, GH, GM, HR, HU, ID, IL, IN, IS, JP, KE, KG, KP, KR, KZ, LC, LK, LR, LS, LT, LU, LV, MA, MD, MG, MK, MN, MW, MX, MZ, NA, NI, NO, NZ, OM, PG, PH, PL, PT, RO, RU, SC, SD, SE, SG, SK, SL, SY, TJ, TM, TN, TR, TT, TZ, UA, UG, US, UZ, VC, VN, YU, ZA, ZM, ZW.
- (84) Designated States (unless otherwise indicated, for every kind of regional protection available): ARIPO (BW, GH, GM, KE, LS, MW, MZ, NA, SD, SL, SZ, TZ, UG, ZM, ZW), Eurasian (AM, AZ, BY, KG, KZ, MD, RU, TJ, TM), European (AT, BE, BG, CH, CY, CZ, DE, DK, EE, ES, FI, FR, GB, GR, HU, IE, IT, LU, MC, NL, PL, PT, RO, SE, SI, SK, TR), OAPI (BF, BJ, CF, CG, CI, CM, GA, GN, GQ, GW, ML, MR, NE, SN, TD, TG).
- Published:**
— with international search report
- For two-letter codes and other abbreviations, refer to the "Guidance Notes on Codes and Abbreviations" appearing at the beginning of each regular issue of the PCT Gazette.

(54) Title: MODULE AND FRAME FOR CABLE ENTRIES

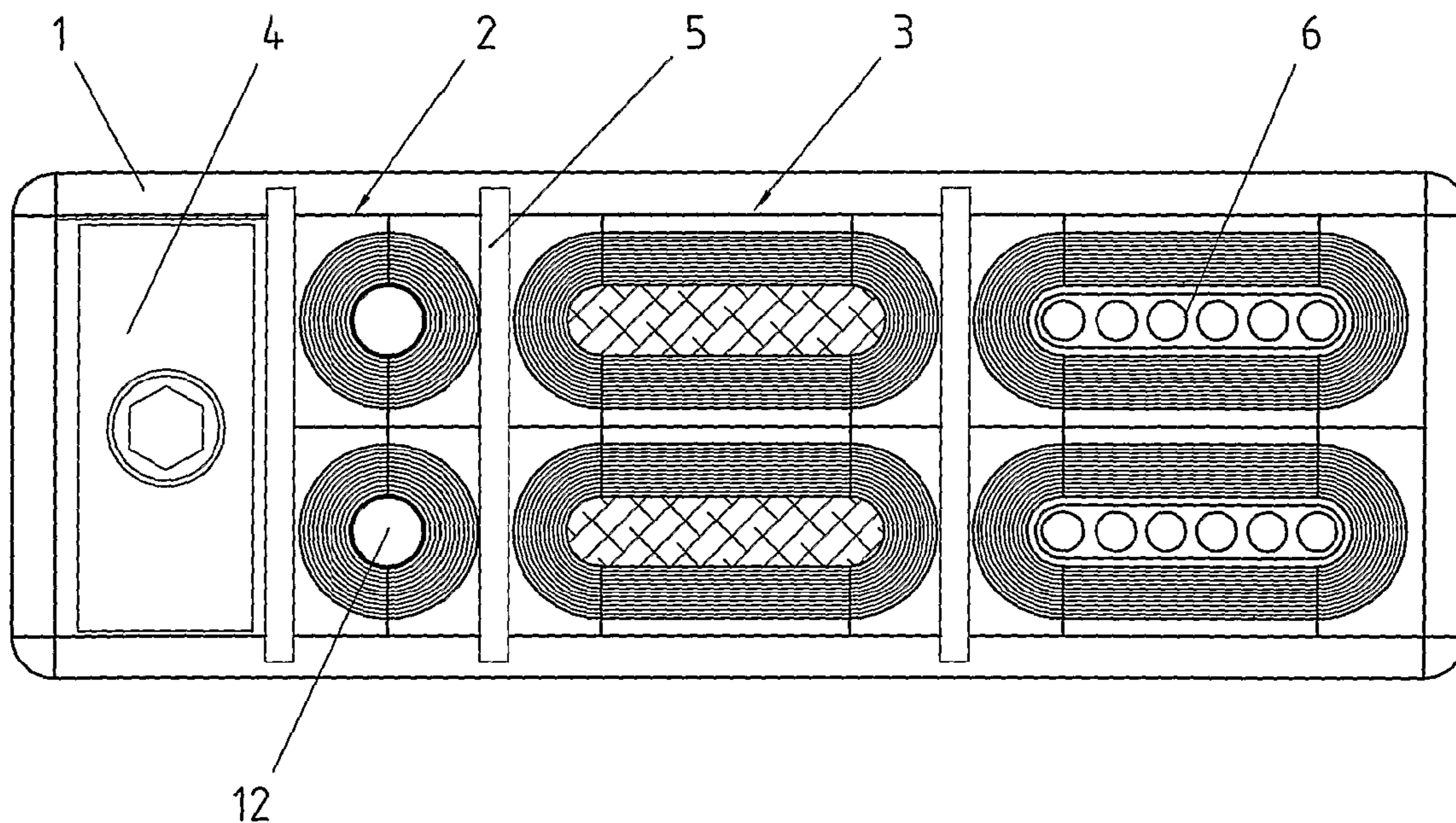

(57) Abstract: The present invention concerns a module (3) and a frame (1) for cable entries, pipe penetrations etc. The module (3) has end parts (7) and middle parts (8) adaptable to receive flat cables (6) or the like having an elongated cross section. The end parts (7) may be identical to parts forming a module (2) for receiving cables, pipes etc. having a circular cross section. The frame (1) is to receive one or more of said module (3).

WO 2004/112211 A1

APPLICANT: ROXTEC INTERNATIONAL AB
TITLE: Module and Frame for Cable Entries

5

Technical Field

The present invention concerns a module and frame for
10 cable entries, pipe penetrations etc.

Prior Art

Frames of different kinds are normally used for cable
entries, pipe penetrations etc. The frame may receive ca-
15 bles for electricity, communication, computers etc. or
pipes for different gases or liquids such as water, com-
pressed air, hydraulic fluid and cooking gas. It is used in
many different environments, such as for cabinets, techni-
cal shelters, junction boxes and machines and also decks
20 and bulkheads of ships. The frames may also be mounted in
walls or roofs of different types of buildings.

Different modules adapted to the cables or pipes to
be received are normally included in the frames. However,
these modules are normally only adapted to cables, pipes or
25 the like having a circular cross section. There are no spe-
cial modules for flat cables or the like. When receiving
flat cables it has been common to make special arrangements
in each frame. The person mounting the cables, pipes or the
like has made the adaptation. Thereby the result has in
30 some degree been depending on the skill of the person
mounting the cables etc. Thus, there is a need of modules
that may be readily adapted to the flat cables or the like
to be received in the frame.

35 Summary of the Invention

The invention is developed concerning parts not hav-
ing a circular cross section, e.g. flat cables. One object

of the present invention is that the frame should be possible to adapt to the cross section of the part to be received.

This object is met by a module to be received in a frame for cable entries, pipe penetrations etc. The module has parts adaptable to receive flat cables or the like, having an elongated cross section.

A further object of the present invention is that handling should be improved, concerning mounting, storing as well as transport.

The modules used are preferably adaptable to cables of different dimensions, by means of peelable sheets. The sheets are held together by an adhesive effect. The adhesive effect is strong enough to normally keep the sheets together, but not stronger than making it possible to peel off a separate sheet by hand.

Further objects and advantages of the present invention will be obvious for a person skilled in the art when reading the detailed description of at present preferred embodiments below.

In one aspect, the invention provides a module to be received in a frame for cable entries and/or pipe penetrations, the module comprising:

two end parts; and

two middle parts placed between the end parts to receive flat cables and/or pipes having an elongated cross section, wherein each middle part is formed of a base plate and a number of sheets that may be peeled off to adapt the middle part to the flat cable or the flat pipe to be received.

Brief Description of the Drawings

The invention will be described further below by way of examples and with reference to the enclosed drawings.

Fig. 1 shows an example of a frame having a module according to the present invention, and

Fig. 2 is an exploded view of a module according to the present invention.

2a

Detailed Description of Preferred Embodiments

In Fig. 1 a frame 1 for cable entries, pipe penetrations etc. is shown. The frame 1 is to be received in a wall, top, roof etc. As is known in the art a number of modules 2, 3 are received in the frame 1. The modules 2, 3 are made of an elastic material. In order to give a tight

seal a wedge 4 or other tensioning means is arranged to put pressure on the modules 2, 3, which will expand outwardly due to the pressure. Between each set of modules 2, 3 a partition 5 is arranged. The partitions 5 are arranged in such a way that they may slide in the frame 1, due to the pressure exerted by the wedge 4.

Of the shown modules 2, 3 one type of module 2 is for cables, pipes or the like having a circular outer circumference. This type of module is well known in the art and will not be described extensively here. The other module 3 is to receive flat cables 6 or other parts having an elongated and rounded outer circumference.

Even though the flat cables 6 are shown in Fig. 1 having a cross section with rounded, semicircular ends, a person skilled in the art realises that the flat cables 6 may have other cross section forms. The present invention has proved useful also for flat cables having a more or less rectangular cross section. The corners of the cross section of the cable often being somewhat rounded. The latter cases function due to the fact that the modules 3 are elastic enough to take up the deviating cross sections. Thus, end parts 7 having a rounded inner surface facing the cable may be used even if the opposing surface of the cable is virtually straight.

The module 3 for flat cables 6 has two end parts 7, which may correspond to or be identical with the parts of the module 2 for cables etc. having a circular cross section. Between the end parts 7 two middle parts 8 are arranged. The end parts 7 have a number of sheets 9 that may be peeled off to adapt the end parts 7 to the part to be received. In the same way the middle parts 8 have sheets 10 that may be peeled off. Further, each middle part 8 has a base plate 11. The base plate 11 is placed at the side of the middle part 8 that is to be directed away from the cable 6 or the like at mounting. The end parts 7 have base

units 14 having a rectangular outer configuration and a circular inner configuration. The circular inner configuration is to receive a cable, pipe or the like. The peeling sheets 9 are received on the inside of the circular part.

5 Depending on the dimensions of the flat cable 6 the middle parts 8 of the module 3 may have varying length. Usually it is enough to have a number of standard lengths for the middle parts 8. It is also possible to have middle parts 8 that are relatively long, in which case the middle parts are cut to an appropriate length before mounting.

10 When the end parts 7 are used for a module 2 with circular inner cross section, a blind rod 12 is usually furnished to facilitate storing, transport and mounting. In the modules 3 for flat cables 6 the blind rod 12 is replaced with a blind plate 13 placed between the middle parts 8. The blind plate 13 has rounded ends to be received in the end parts 7. In some embodiments there are no blind plates 13.

20 As mentioned above identical units may be used for the modules 2 for circular cables, pipes etc. and for the end parts 7 of the modules 3 for flat cables or the like. The use of identical units facilitates handling and storing.

25 In use the blind plate 13 is first taken away when a flat cable 6 or the like is to be brought through the frame 1. Then the appropriate number of sheets 9, 10 are peeled off from the end parts 7 and middle parts 8, respectively. The appropriate number of sheets 9, 10 is that number that is needed to give room for the flat cable 6 in the module 3. When the cables, pipes or the like have been mounted in the frame 1 the wedge 4 or other tensioning means is manipulated to put pressure on the modules 2, 3 having cables, pipes, blinds 11, 12 etc. Due to the pressure exerted by the wedge 4 or the like the elastic material of the mod-

ules will expand in the other directions, giving a tight seal.

The embodiments of the invention in which an exclusive property or privilege is claimed are defined as follows:

1. A module to be received in a frame for cable entries and/or pipe penetrations, the module comprising:
 - two end parts; and
 - two middle parts placed between the end parts to receive flat cables and/or pipes having an elongated cross section, wherein each middle part is formed of a base plate and a number of sheets that may be peeled off to adapt the middle part to the flat cable or the flat pipe to be received.
2. The module of claim 1, wherein each end part has a number of sheets, giving a rounded form to receive an end of the flat cable and/or the flat pipe, and which sheets may be peeled off to adapt the end part to the received flat cable or the flat pipe.
3. The module of claim 1 or 2, wherein the base plate is to be directed away from the flat cable or the flat pipe at mounting in a frame.
4. The module of any one of claims 1 to 3, wherein it is made of an elastic material.
5. The module of any one of claims 1 to 4, wherein a blind plate is arranged encircled by the end and middle parts.
6. A frame for cable entries or pipe penetrations, wherein the frame receives one or more modules as defined in any one of claims 1 to 5.

7. The frame of claim 6, comprising tensioning means.
8. The frame of claim 7, wherein the tensioning means is a wedge.

1/1

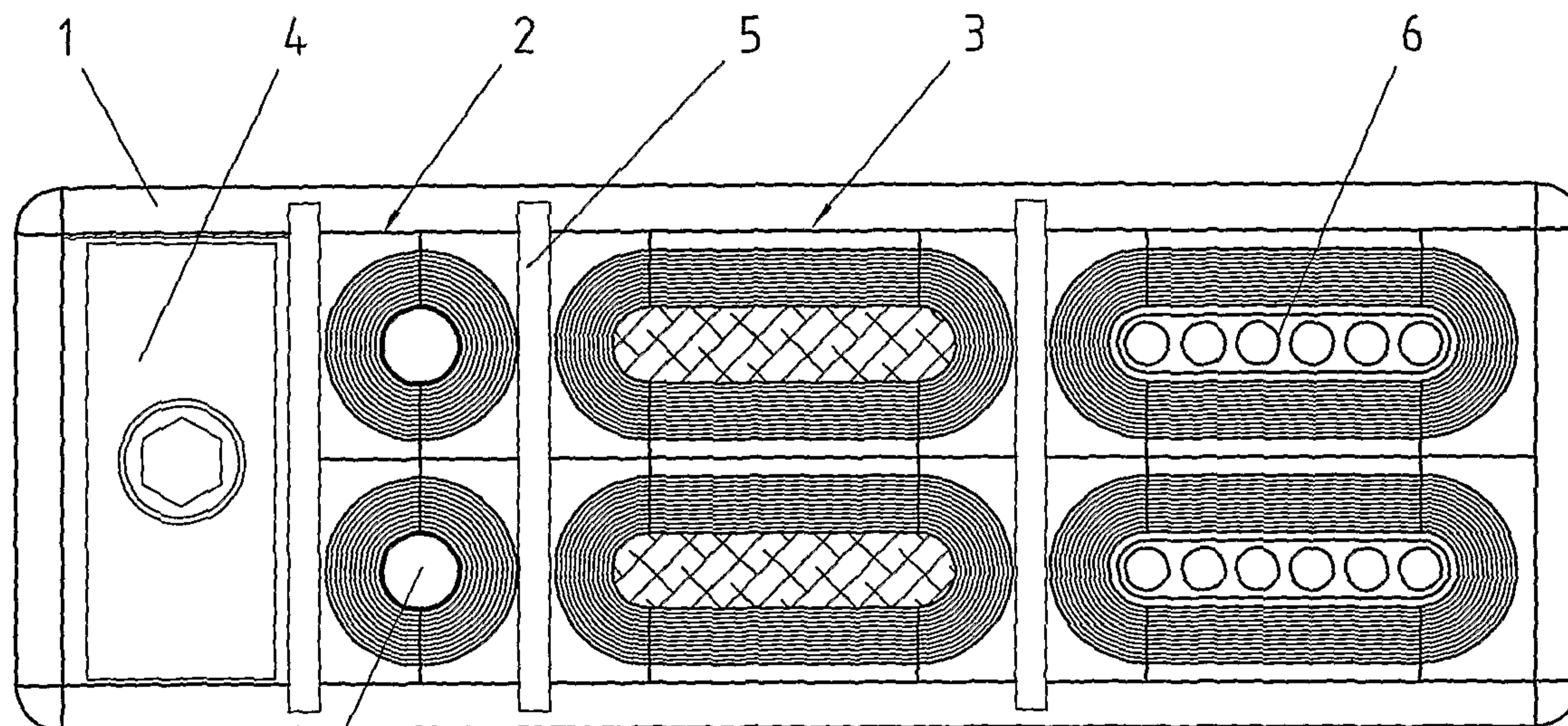

FIG. 1

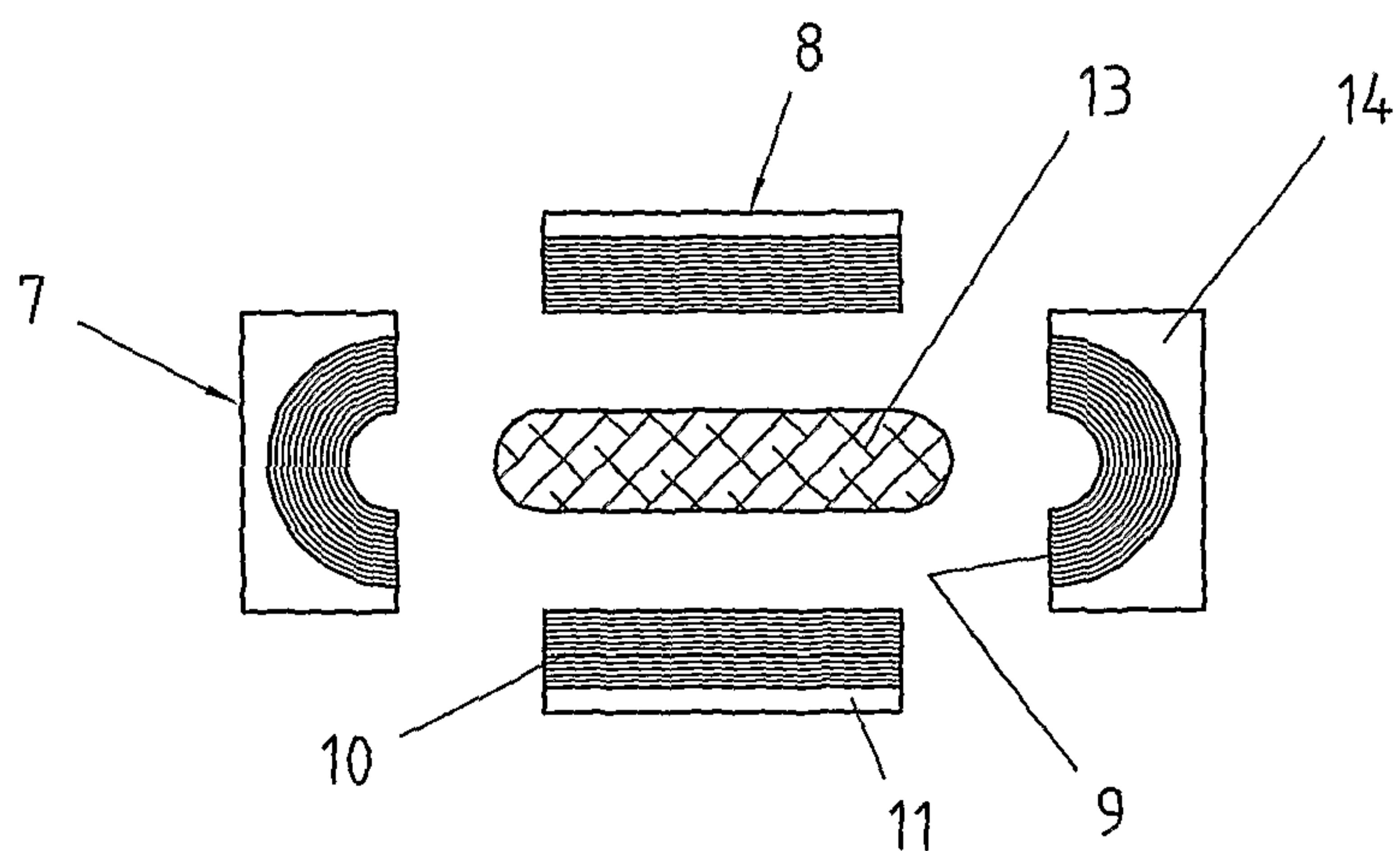

FIG. 2

