

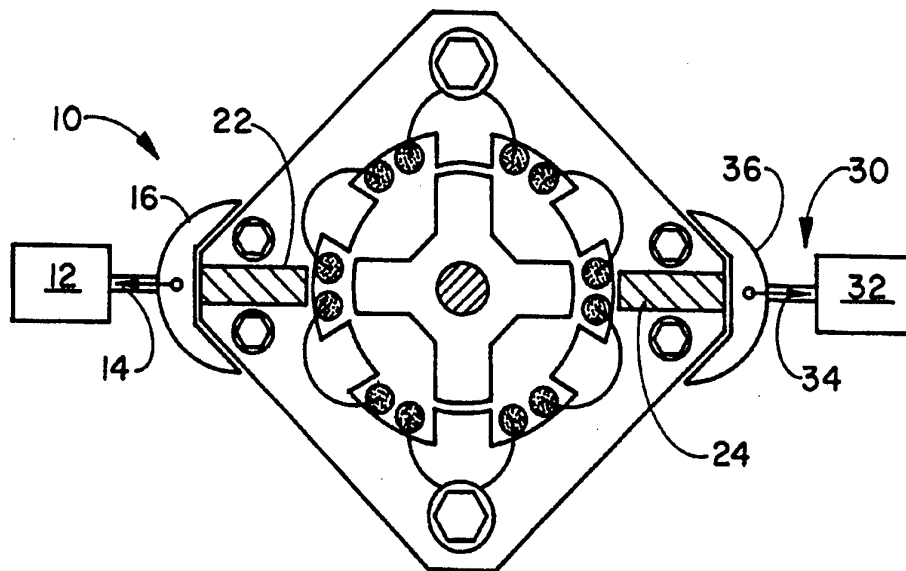

INTERNATIONAL APPLICATION PUBLISHED UNDER THE PATENT COOPERATION TREATY (PCT)

<p>(51) International Patent Classification⁵ : H02K 1/17, 37/04, 37/24, H02P 5/28, 7/36</p>	<p>A1</p>	<p>(11) International Publication Number: WO 94/19855 (43) International Publication Date: 1 September 1994 (01.09.94)</p>
<p>(21) International Application Number: PCT/US94/01745 (22) International Filing Date: 15 February 1994 (15.02.94) (30) Priority Data: 08/017,833 16 February 1993 (16.02.93) US (71) Applicant: ELECTRIC POWER RESEARCH INSTITUTE, INC. [US/US]; 3412 Hillview Avenue, P.O. Box 10412, Palo Alto, CA 94303 (US). (72) Inventors: LIPO, Thomas, A.; 7710 Bittersweet Court, Middleton, WI 53562 (US). LIAO, Yuefeng; 909-B Eagle Heights, Madison, WI 53705 (US). LIANG, Feng; 37910 Westwood Circle, Westland, MI 48185 (US). (74) Agent: GAMSON, Robert, M.; Bloom & Kreten, Suite 905, 401 Washington Avenue, Towson, MD 21204 (US).</p>		<p>(81) Designated States: AU, CA, JP, European patent (AT, BE, CH, DE, DK, ES, FR, GB, GR, IE, IT, LU, MC, NL, PT, SE). Published <i>With international search report. Before the expiration of the time limit for amending the claims and to be republished in the event of the receipt of amendments.</i></p>

(54) Title: FIELD WEAKENING FOR A DOUBLY SALIENT MOTOR WITH STATOR PERMANENT MAGNETS



(57) Abstract

A device for field weakening in a doubly-salient variable reluctance motor having permanent magnets (22, 24) in the stator (10). The field weakening increases the constant power range of the motor and is accomplished by controlled movement of steel insets (16, 36) toward and away from the sides of the stator (10) proximate the permanent magnets (22, 24) to provide a controllable by-pass flux path thereabout. Alternatively, the field weakening may be accomplished by a flux by-pass collar (40) which may be angularly positioned around the stator (10) to bridge the permanent magnets (22, 24) of the motor with discrete magnetic sections, thereby providing an alternate by-pass flux path around the permanent magnets (22, 24) in addition to the main air gap flux path. A third alternative means for maintaining a constant power range is accomplished by controlled axial sliding of the permanent magnets (22, 24) themselves into and out from the stator (10).

FOR THE PURPOSES OF INFORMATION ONLY

Codes used to identify States party to the PCT on the front pages of pamphlets publishing international applications under the PCT.

AT	Austria	GB	United Kingdom	MR	Mauritania
AU	Australia	GE	Georgia	MW	Malawi
BB	Barbados	GN	Guinea	NE	Niger
BE	Belgium	GR	Greece	NL	Netherlands
BF	Burkina Faso	HU	Hungary	NO	Norway
BG	Bulgaria	IE	Ireland	NZ	New Zealand
BJ	Benin	IT	Italy	PL	Poland
BR	Brazil	JP	Japan	PT	Portugal
BY	Belarus	KE	Kenya	RO	Romania
CA	Canada	KG	Kyrgyzstan	RU	Russian Federation
CF	Central African Republic	KP	Democratic People's Republic of Korea	SD	Sudan
CG	Congo	KR	Republic of Korea	SE	Sweden
CH	Switzerland	KZ	Kazakhstan	SI	Slovenia
CI	Côte d'Ivoire	LI	Liechtenstein	SK	Slovakia
CM	Cameroon	LN	Lithuania	SN	Senegal
CN	China	LK	Sri Lanka	TD	Chad
CS	Czechoslovakia	LU	Luxembourg	TG	Togo
CZ	Czech Republic	LV	Latvia	TJ	Tajikistan
DE	Germany	MC	Monaco	TT	Trinidad and Tobago
DK	Denmark	MD	Republic of Moldova	UA	Ukraine
ES	Spain	MG	Madagascar	US	United States of America
FI	Finland	ML	Mali	UZ	Uzbekistan
FR	France	MN	Mongolia	VN	Viet Nam
GA	Gabon				

**FIELD WEAKENING FOR A DOUBLY SALIENT
MOTOR WITH STATOR PERMANENT MAGNETS**

BACKGROUND OF THE INVENTION

1. Field of the Invention

5 The present invention relates to high-output permanent magnet motors incorporating a doubly salient structure with stationary permanent magnets in the stator and, more particularly, to field weakening via controlled movement of steel insets toward/against the sides of the stator near the
10 permanent magnets to provide a controllable by-pass flux path thereabout. Appropriate control broadens the constant power range of the motor.

2. Description of the Background

15 In a variable reluctance motor (VRM), torque is generated by a doubly-salient rotor and stator which tend to align themselves in order to reach a position of minimum magnetic reluctance. Under ideal switching conditions, VRMs have the potential to be highly efficient. Unfortunately, actual
20 switching conditions are less than ideal, and attempts to achieve such conditions have resulted in commercially impractical converter circuits with excessive voltage and current stresses imparted to the switching devices. In a drive utilizing a variable reluctance motor, the current in each phase should be decreased to zero immediately when the
25 rotor is aligned with that phase. The problem lies in the existence of a large turn-off inductance. The phase inductance is a maximum when the rotor is aligned with that phase. Since this large inductance will prevent rapid decrease of the current due to the energy stored in the
30 magnetic field, the current in each phase cannot immediately be decreased to zero when the rotor reaches alignment. Consequently, the decaying residual current induces a detrimental reverse-torque as the rotor pole surpasses alignment with the corresponding stator pole. The problem is
35 most serious when the speed of the motor is high.

 One solution to the above-described problem was provided in U.S. Patent Application Serial No. 07/926,765, filed

August 6, 1992. A new type of permanent magnet motor was therein disclosed which incorporated a doubly salient structure with stationary permanent magnets in the stator.

FIG. 1 shows a cross-section of a doubly salient stationary permanent magnet motor (DS²PM) as set forth in U.S. Patent Application Serial No. 07/926,765, filed August 6, 1992.

A stator 10 consists of a plurality of discrete laminated layers, each layer being punched to form six salient (or projecting) poles 12 positioned at angular intervals θ_s of $\pi/3$ radians. Each pole 12 has a pole arc θ_{ps} of $\pi/6$ radians.

The rotor 16 also consists of a plurality of discrete laminated layers each of which is punched to form four salient poles 18 positioned at angular intervals θ_r of $\pi/2$. Each pole 18 also has a pole arc θ_{pr} equal to or slightly greater than $\pi/6$ radians.

In the DS²PM embodiment of FIG. 1, stator 10 is wound with three short pitch windings corresponding to three phases A-C. Each short pitch winding (for example, the winding of phase A) further comprises two short pitch coils $A_{1,2}$ connected in series, and the coils A_1 and A_2 of each winding are wound around a diametrically opposite pair of stator poles 12.

In addition, two permanent magnets 22 and 24 are embedded inside the stator 10. The inclusion of permanent magnets 22 and 24 in the stator 10 rather than the rotor 16 has distinct advantages in that the motor is able to run at higher speed, the motor may be manufactured at a lower manufacturing cost, and the motor lends itself to better field weakening operation performance.

The permanent magnets 22 and 24 themselves generate the primary flux, and a secondary (armature reaction) flux is induced by the stator pole windings A-C. Due to their air-like permeability, permanent magnets 22 and 24 present a very high bi-planar reluctance which blocks the ordinary path of the secondary flux through the stator 10.

The particular stator pole 12 and rotor pole 18 arrangement of the present invention ensures that the total

overlapped pole area remains constant for all positions of rotor 16. This way, the total air-gap reluctance (which is the primary reluctance for the permanent magnet excitation) is invariant to rotor 16 displacement θ_d , and there exists a substantially linear transfer of permanent magnet flux between adjacent stator poles 12 during rotation of rotor 16. Consequently, permanent magnets 22 and 24 produce no cogging torque at no load.

Since torque is produced as a result of the change of flux linkage in the active stator winding(s) A-C, there is a reaction torque component caused by the interaction of stator winding current and the permanent magnet flux, and this reaction torque is the dominant driving torque of the motor. There is also a reluctance torque component caused by the variation in the reluctance of the magnetic path of the winding A-C. Hence, the DP²VRM works on the variable reluctance principle as well as permanent magnet brushless DC motor principles.

Insofar as the reaction torque component, FIG. 2 shows the variations of the currents i and the corresponding flux linkages λ in each phase resulting from the permanent magnets 22 and 24. Positive current is injected into a given phase when the magnetic flux linking that phase is increasing, and negative current is injected when the magnetic flux is decreasing. Consequently, a positive reaction torque component can be produced over the entire area of overlap of an active stator pole 12 and rotor pole 18 pair.

Insofar as the reluctance torque component, the reluctance torque τ_{er} in the respective phases will be of zero average if the amplitudes of the positive and negative pulses of the corresponding phase currents are kept constant and equal to each other by means of pulse width modulation of the associated power converter. In addition, the instant of reversal of the currents i_a , i_b , and i_c applied to the stator windings must be kept centered about the peak of the triangle-shaped flux-linkage variations λ_a , λ_b , and λ_c as shown in FIG. 2.

Under high speed operation, the associated power converter is no longer capable of maintaining the current amplitudes of the positive and negative pulses constant by means of pulse width modulation. In this case, the voltage applied to the motor of FIG. 1 will be simple positive and then negative rectangular pulses over the instants when the desired current should be positive and negative. This is single pulse operation.

Given that the DS²VRM will be powered by conventional single pulse operation at high speed, the phase currents will no longer be constant amplitude pulses at high speed. Consequently, the current will peak in the first half stroke where the inductance is increasing and will drop rapidly during the second half stroke where the inductance is decreasing. The uneven distribution of the uneven distribution of the phase current will give rise to net reluctance torque which can be used to extend the constant horsepower speed range. The presence of reluctance torque in addition to reaction torque markedly enhances the torque production during this mode of operation. Consequently, the constant power range can be extended compared to more conventional permanent magnet machines.

The present application proposes an efficient method and apparatus for accomplishing the above-described field weakening at all speeds of the motor.

SUMMARY OF THE INVENTION

It is an object of the present invention to increase the constant power range of the Stationary Permanent Magnet VRM as set forth in co-pending U.S. Patent Application Serial No. 07/926,765 by field weakening.

It is another object of the present invention to provide a method and apparatus for field weakening in a doubly salient VRM structure with stationary permanent magnets in the stator via controlled radial, axial, or circumferential movement of the permanent magnets or of steel insets which provide a by-pass flux path around the respective permanent magnets.

According to the present invention, the above-described and other objects are accomplished by providing a doubly-salient permanent magnet motor with stationary permanent magnets (i.e., a "DS²PM" motor) and field weakening feature.

5 The DS²PM comprises a rotor having a multiple of four salient poles spaced at equal angular intervals around a central axis. The motor also includes a stator having a multiple of six salient poles spaced at equal angular intervals and three stator windings corresponding to three phase A-C. Each stator
10 winding is coiled around pairs of diametrically opposite stator poles, for example, in the 6/4 stator/rotor pole embodiment each stator winding is coiled around one pair of diametrically opposite stator poles, in the 12/8 stator/rotor pole embodiment each stator winding is coiled around two pair
15 of diametrically opposite stator poles, etc.

The stator further comprises a plurality of planar permanent magnets located on opposing sides of the stator to serve as a means for producing magnetizing flux.

20 The permanent magnets are preferably shaped in parallelepipeds and are arranged on diametrically opposite sides of the stator to serve as a source of flux for magnetizing the reluctance motor.

The field weakening feature is accomplished by an assembly which provides a variable-reluctance flux path around
25 each of the permanent magnets. The field weakening assembly further includes an actuator for imparting controlled axial or radial movement and a steel inset conforming to a side of the stator and coupled to the actuator. The inset may be selectively driven by the actuator against/away from the
30 stator to provide a controlled bypass flux path around one of the permanent magnets. The field weakening assembly may be controlled in accordance with the torque requirements to drive the steel inset toward the stator, thereby promoting the flow of flux around the permanent magnet and reducing the permanent
35 magnetic flux-linkage of the stator windings. Conversely, the field weakening assembly may be controlled to retract the steel inset from the stator, thereby impeding the flow of flux

around the permanent magnet and enhancing the permanent magnetic field.

5 An alternative field weakening feature is accomplished by an assembly which likewise provides a variable-reluctance flux path around each of the permanent magnets. This field
weakening assembly further includes a rotating bypass collar which encircles the stator. The bypass collar is comprised of discrete alternating magnetic/non-magnetic arcuate sections. An actuator (such as a stepping motor) incrementally rotates
10 the bypass collar about the stator to control the alignment of the discrete arcuate sections with the permanent magnets in the stator. The collar can be rotated until the discrete magnetic sections bridge the permanent magnets, thereby providing a controlled bypass flux path around the permanent
15 magnets. Conversely, the collar can be rotated until the discrete non-magnetic sections bridge the permanent magnets, thereby blocking any flux path around the permanent magnets. The discrete magnetic/non-magnetic sections of the collar may be formed with a helical slant such that rotation of the
20 collar around the stator effects a gradual alteration of the bypass flux path, thereby allowing full control over the entire range of possible permanent magnetic flux-linkages of the stator windings.

A third alternative field weakening feature is
25 accomplished by an assembly which moves the permanent magnets themselves out of the stator to reduce the reluctance torque component. This field weakening assembly further includes an actuator for controlled axial extraction/insertion of the permanent magnets out of/into the stator. The permanent
30 magnets may be selectively driven by the actuator in accordance with the torque requirements to control the magnitude of the reluctance torque component generated by the permanent magnets.

BRIEF DESCRIPTION OF THE DRAWINGS

35 Other objects, features, and advantages of the present invention will become more apparent from the following

detailed description of preferred embodiments and certain modifications thereof when taken together with the accompanying drawings in which:

FIG. 1 shows a cross-section of a doubly salient stationary permanent magnet motor as set forth in U.S. Patent Application Serial No. 07/926,765, filed August 6, 1992;

FIG. 2 is a graph of the currents i_{a-c} and the corresponding flux linkages λ_{a-c} in each of the respective phases A-C resulting from the permanent magnets 22 and 24 in the motor of FIG. 1;

FIG. 3 is a cross-section of a doubly salient stationary permanent magnet motor substantially as shown in FIG. 1, with the addition of an apparatus for field weakening in accordance with the present invention;

FIG. 4 is a perspective view of an alternative apparatus for field weakening in accordance with the present invention which is likewise incorporated in a doubly salient permanent magnet motor as shown in FIG. 1; and

FIG. 5 is a cross-sectional view of a third alternative apparatus for field weakening in accordance with the present invention likewise incorporated in a doubly salient permanent magnet motor as shown in FIG. 1.

DETAILED DESCRIPTION OF THE PREFERRED EMBODIMENT

The DS²PM of FIG. 1 operates on the variable reluctance principle as well as permanent magnet brushless DC motor principles. Specifically, the permanent magnets 22 and 24 themselves generate a first (air gap) flux component, while a second (armature reaction) flux component is contributed by the stator pole windings A-C. The reluctance torque τ_{er} in the respective phases will be of zero average if the corresponding phase currents are taken on the quasi-square wave waveform shown in FIG. 2. This is due to the fact that the triangle-shaped flux-linkage variations λ_a , λ_b , and λ_c resulting from flux emanating from the magnets 22 and 24 and couple to the three stator windings A-C produce quasi-square EMFs in the windings (the EMFs being the time derivative of the flux

linkages). The sum of the products of the EMFs times the respective currents in each phase is well-known to result in the power output. When the stator currents are themselves quasi-square waves (same waveform as the EMFs), the sum of the product of the EMFs times the respective currents in each phase results in a constant torque. Hence, the reaction torque component generated by the interaction of the stator currents with the magnetic flux linkage in each phase from the permanent magnet is the dominant torque producing component. However, due to their air-like permeability, permanent magnets 22 and 24 present a very high bi-planar reluctance which blocks the ordinary path of the armature reaction flux through the stator 10 at pole alignment. Hence, the stator windings meet a very small permeance (high reluctance) at both aligned and unaligned positions. Therefore, the inductance is correspondingly small at these positions so that only a short commutation period is necessary for turn-off of each outgoing phase and turn-on of the incoming phase.

As described above, the DS²PM is generally powered by conventional single pulse operation at high speed and by pulse width modulation (PWM) at low speeds. At high speeds, the phase currents will not remain constant. Consequently, the motor will pick up a net reluctance torque. The presence of reluctance torque in addition to reaction torque enhances the overall torque production during high speed operation. There are many known applications for permanent magnet motors wherein the torque must be maintained constant, and the changing torque characteristics in the DS²PM presents a problem.

Field weakening is an effective technique for broadening the constant power range of a motor at speeds above the point where the power supply (in this case, a solid state power converter) reaches its maximum voltage in an effort to control the quasi-rectangular current waveform of FIG. 1.

FIG. 3 is a cross-sectional view of a salient permanent magnet motor substantially as set forth in co-pending U.S. Patent Application Serial No. 07/926,765. In addition, the

motor of FIG. 3 incorporates an apparatus for field weakening in accordance with the present invention.

Field weakening is achieved by a pair of flux diversion assemblies 10 and 30 which are operative at the ends of the respective permanent magnets 22 and 24 for providing a by-pass flux path thereabout.

The first flux diversion assembly 10 further comprises an actuator 12 which may be an electro-mechanical solenoid-type actuator, hydraulic, or any other conventional device for imparting axial movement in either a linear, gradual or step-wise manner. Actuator 12 is operatively connected to a steel inset 16 via actuating arm 14.

Likewise, the second flux diversion assembly 30 further comprises an actuator 32 which may be an electro-mechanical solenoid-type actuator or any other conventional device for imparting axial movement. Actuator 32 is operatively connected to a steel inset 36 via actuating arm 34.

The steel insets 16 and 36 preferably conform closely to the corners of the motor in which permanent magnets 22 and 24 are normally mounted so as to minimize the reluctance seen by the magnets 22 and 24 and armature reaction MMF when the steel insets 16 and 36 are in their minimum reluctance (maximum field weakening) position.

Actuators 12 and 32 operate through arms 14 and 34 to allow controlled axial movement of the respective steel insets 16 and 36 toward and away from the respective permanent magnets 22 and 24.

Hence, the flux diversion assemblies 10 and 30 can be operated to drive steel insets 16 and 36 into a first position wherein contact is made on both sides of permanent magnet 22 by inset 16, and similarly, contact is made on both sides of permanent magnet 24 by inset 36. In this first position, insets 16 and 36 each provide a by-pass flux path around the respective permanent magnets 22 and 24. Although the air-like permeability of permanent magnets 22 and 24 blocks the ordinary path of the armature reaction flux through the stator at pole alignment, a by-pass path is provided through

insets 16 and 36. As a result, the armature reaction flux is free to flow around the permanent magnets 22 and 24 and their magnetic effect is nullified. In a similar manner, some of the permanent magnet flux is diverted through the shorting
5 by-pass so that the magnet flux which enters the air gap, and thus links the stator windings A-C, is correspondingly reduced. In this first position, when essentially all of the permanent magnet and armature reaction flux is diverted through the bypass, the motor operates as a conventional
10 switched reluctance motor.

Conversely, the flux diversion assemblies 10 and 30 can be operated to retract steel insets 16 and 36 into a second position away from the respective permanent magnets 22 and 24. In this second position, the motor works primarily on the
15 permanent magnet brushless DC motor principle.

Of course, various degrees of flux diversion around the respective permanent magnets 22 and 24 may be achieved by operation of the flux diversion assemblies 10 and 30 to position steel insets 16 and 36 at points between the first
20 and second positions.

In accordance with the method of the present invention, the flux diversion assemblies 10 and 20 are employed when the motor is being run at high speed to drive steel insets 16 and 36 into the first position wherein contact is made on both
25 sides of permanent magnet 22 by inset 16, and similarly, contact is made on both sides of permanent magnet 24 by inset 36. This way, the reluctance component of the flux due to permanent magnets 22 and 24 circulates through the by-pass flux paths through steel insets 16 and 36. The permanent
30 magnetic field is weakened, and the motor operates as a conventional switched reluctance motor.

Conversely, the flux diversion assemblies 10 and 20 are employed when the motor is being run at low speed to retract steel insets 16 and 36 into the second position wherein an air
35 gap separates the insets 16 and 36 from the permanent magnets 22 and 24. This way, the armature reaction component of the flux is inhibited by permanent magnets 22 and 24 since it is

unable to flow through the by-pass flux paths through steel insets 16 and 36. The permanent magnetic field is enhanced, and the motor operates as the Stationary Permanent Magnet VRM as set forth in co-pending U.S. Patent Application Serial No. 07/926,765.

The flux diversion assemblies 10 and 20 may be operated pursuant to the speed of the motor to effect continuous positioning of steel insets 16 and 36 at various points between the first and second positions, thereby effecting various degrees of field weakening in order to maintain constant power.

Hence, by employing the above-described field weakening scheme, a Stationary Permanent Magnet VRM as set forth in co-pending U.S. Patent Application Serial No. 07/926,765 can be made to gradually transition from pure permanent magnet operation at low speed to switched reluctance motor operation at high speed while maintaining the output power constant.

The use of field weakening in accordance with the present invention allows a constant power range of 5:1 or more, and such specifications are highly desirable for certain traction applications. Moreover, the device for field weakening according to the present invention may easily and economically be incorporated in any permanent magnet VRM embodiment having permanent magnets in the stator.

FIG. 4 is a perspective view of an alternative apparatus for field weakening in accordance with the present invention which is likewise incorporated in a salient permanent magnet motor substantially as set forth in co-pending U.S. Patent Application Serial No. 07/926,765.

In the embodiment of FIG. 4, field weakening is achieved by a flux diversion collar 40 which encircles stator 10 and is rotatably mounted thereon. Flux diversion collar 40 is formed from a plurality of alternate magnetic/non-magnetic discrete sections. The flux diversion collar 40 is rotatably driven to allow incremental control of the angular position of collar 40. The discrete magnetic sections of collar 40 may then be selectively positioned to bridge the permanent magnets 22 and

24, thereby establishing a by-pass flux path thereabout. Conversely, the discrete non-magnetic sections of collar 40 may be selectively positioned to bridge the permanent magnets 22 and 24, thereby preventing any by-pass flux. Preferably, the magnetic/non-magnetic discrete sections of collar 40 are formed with a slight helical slant. This way, the axial extent of the by-pass flux path may be varied, and the discrete magnetic sections of collar 40 may be positioned to establish a by-pass path of any size.

10 The flux diversion collar 40 is driven by an actuator (not shown) which may be an electro-mechanical solenoid-type actuator, hydraulic, or any other conventional device for controlling the angular position. A stepping motor is well-suited for this purpose.

15 The collar 40 preferably conforms closely to the circumference of the stator 10 so as to minimize the reluctance seen by the magnets 22 and 24 and armature reaction MMF when the discrete non-magnetic sections are in their minimum reluctance (maximum field weakening) positions spanning the permanent magnets 22 and 24.

20 In accordance with the previously described method of the present invention, the collar 40 is positioned when the motor is being run at high speed to position the discrete magnetic sections of steel over permanent magnet 22 and 24 to establish a by-pass flux path. This way, a component of the flux due to permanent magnets 22 and 24 circulates through the by-pass flux paths through collar 40. The permanent magnet field in the air gap is weakened, and the motor operates as a conventional switched reluctance motor. Conversely, the collar 40 is positioned when the motor is being run at low speed to position the discrete non-magnetic sections steel over permanent magnet 22 and 24 to eliminate the by-pass flux path. This way, the armature reaction component of the flux is inhibited by permanent magnets 22 and 24 since it is unable to flow through the by-pass flux paths. The permanent magnetic field in the air gap is enhanced, and the motor

operates as the Stationary Permanent Magnet VRM as set forth in co-pending U.S. Patent Application Serial No. 07/926,765.

When the sections of collar 40 are formed with a helical slant as shown, the collar 40 may be rotated in accordance with the speed of the motor to effect various degrees of field weakening in order to maintain constant power. It should be noted that it is not necessary to continuously rotate the collar 40 to effect field weakening. With a helical slant as shown in FIG. 4, it is estimated that a full range of field weakening may be achieved by a 30° angular adjustment.

FIG. 5 is a cross-sectional view of yet another alternative apparatus for field weakening in accordance with the present invention. The embodiment of FIG. 5 is likewise incorporated in a salient permanent magnet motor substantially as set forth in co-pending U.S. Patent Application Serial No. 07/926,765.

In the embodiment of FIG. 5, field weakening is achieved by moving the permanent magnets 22 and 24 themselves. Preferably, each permanent magnet further comprises two separable sections, for example, permanent magnet 22 comprises sections 22A and 22B as shown. The axially stacked laminations of stator 10 are formed to allow the sections of permanent magnets 22 and 24 to slide apart and out of stator 10 in the axial direction indicated in FIG. 5.

An actuator 132 is provided to insert and retract one section 22A of permanent magnet 22, and a second actuator 136 is provided to insert and retract the other section 22B. Both actuators 132 and 136 may be electro-mechanical solenoid-type actuators or any other conventional device for imparting axial movement. Actuator 132 is operatively connected to permanent magnet section 22A via actuating arm 134, and actuator 136 is operatively connected to permanent magnet section 22B via actuating arm 138.

Actuators 132 and 136 operate through arms 134 and 138 to allow controlled axial movement of the respective permanent magnet sections 22A and 22B into and out from the stacked laminations of the stator 10.

An identical arrangement is provided to operate permanent magnet sections 24A and 24B (not shown).

Hence, the actuators 132 and 136 can be operated to drive permanent magnet sections 22A and 22B into a first fully-
5 inserted position when the motor is being run at low speed, and the same is done to permanent magnet sections 24A and 24B (not shown), to thereby increase the reluctance torque component of magnets 22 and 24. The permanent magnet field in the air gap is enhanced, and the motor operates as the
10 Stationary Permanent Magnet VRM as set forth in co-pending U.S. Patent Application Serial No. 07/926,765.

Conversely, the actuators 132 and 136 can be operated to extract permanent magnet sections 22A and 22B to a second position when the motor is being run at high speed, and the
15 same is done to permanent magnet sections 24A and 24B (not shown), to thereby reduce the reaction torque component of magnets 22 and 24.

The actuators 132 and 136 may be operated in accordance with the speed of the motor to effect various degrees of
20 reluctance torque in order to maintain constant power.

Having now fully set forth the preferred embodiments and certain modifications of the concept underlying the present invention, various other embodiments as well as certain variations and modifications of the embodiment herein shown
25 and described will obviously occur to those skilled in the art upon becoming familiar with said underlying concept. It is to be understood, therefore, that within the scope of the appended claims, the invention may be practiced otherwise than as specifically set forth herein.

We claim:

1. A permanent magnet motor comprising:

a rotor, said rotor further comprising,

a plurality of salient poles spaced at equal angular intervals around a central axis;

a stator for exciting said rotor to move, said stator further comprising,

a plurality of salient poles spaced at equal angular intervals around a central axis, said stator poles being arranged with respect to said rotor poles to provide a constant air-gap reluctance during rotation of said rotor within said stator, and

a plurality of permanent magnets shaped in parallelepipeds and arranged on diametrically opposite sides of said stator to serve as a source of flux for magnetizing the motor; and

a field weakening assembly for providing a variable-reluctance flux path around said permanent magnets, said field weakening assembly further comprising,

an actuator for imparting a controlled axial movement,

a steel inset conforming to a side of said stator, said steel inset being coupled to said actuator and selectively driven thereby against and away from a side of said stator to provide a controlled bypass flux path around one of said permanent magnets;

whereby the field weakening assembly may be controlled in accordance with the torque requirements to drive the steel inset toward the side of said stator, thereby promoting a flow of flux around said permanent magnet and reducing a magnetic field of said permanent magnet, and the field weakening assembly may be controlled to retract the steel inset away from the side of said stator, thereby impeding a flow of flux around said permanent magnet and enhancing a magnetic field of said permanent magnet.

2. The permanent magnet motor of claim 1 wherein said plurality of permanent magnets further comprises a first permanent magnet and a second permanent magnet shaped as elongate parallelepipeds and parallelly spaced on opposing sides of said rotor axis, and

said field weakening assembly further comprises a first actuator coupled to a first steel inset for imparting a controlled radial movement thereto toward and away from said first permanent magnet, and a second actuator coupled to a second steel inset for imparting a controlled radial movement thereto toward and away from said second permanent magnet.

3. The permanent magnet motor of claim 2 wherein said plurality of stator poles further comprises a multiple of six stator poles evenly spaced at angular intervals equal to a multiple of $\pi/3$ radians.

4. The permanent magnet motor of claim 3 wherein said stator poles have a pole arc equal to a multiple of $\pi/6$ radians.

5. The permanent magnet motor of claim 2 wherein said plurality of rotor poles further comprises a multiple of four rotor poles evenly spaced at angular intervals equal to a multiple of $\pi/2$ radians.

6. The permanent magnet motor of claim 5 wherein said rotor poles have a pole arc equal to a multiple of $\pi/6$ radians.

7. The permanent magnet motor of claim 5 wherein said permanent magnets each have planar faces which are angularly displaced by a multiple of $\pi/6$ radians from one of said stator poles.

8. The permanent magnet motor of claim 5 wherein said stator further comprises a plurality of stator windings

corresponding to an equal number of phases, each stator winding being coiled around two diametrically opposite stator poles.

9. The permanent magnet motor of claim 3 wherein said plurality of stator poles further comprises six stator poles evenly spaced at angular intervals of $\pi/3$ radians.

10. The permanent magnet motor of claim 9 wherein said stator poles have a pole arc equal to $\pi/6$ radians.

11. The permanent magnet motor of claim 9 wherein said plurality of rotor poles further comprises four rotor poles evenly spaced at angular intervals of $\pi/2$ radians.

12. The permanent magnet motor of claim 11 wherein said rotor poles have a pole arc of at least $\pi/6$ radians.

13. The permanent magnet motor of claim 11 wherein said permanent magnets each have planar faces which are angularly displaced by a multiple of $\pi/6$ radians from one of said stator poles.

14. The permanent magnet motor of claim 11 wherein said stator further comprises three stator windings corresponding to three phases, each stator winding being coiled around two diametrically opposite stator poles.

15. A permanent magnet motor comprising:
a rotor having four salient poles spaced at equal angular intervals around a central axis; and
a stator having six salient poles spaced at equal angular intervals around said central axis, and three stator windings corresponding to three phases, each stator winding being coiled around two diametrically opposite stator poles, said stator further comprising a plurality of permanent magnets shaped in parallelepipeds and arranged on diametrically

opposite sides of said stator to serve as a source of flux for magnetizing the reluctance motor; and

a field weakening assembly for providing a variable-reluctance flux path around said permanent magnets, said field weakening assembly further comprising,

a first steel inset conforming to one side of said stator proximate one of said permanent magnets,

a second steel inset conforming to another side of said stator proximate another diametrically opposite permanent magnet,

a first actuator coupled to said first steel inset for imparting a controlled radial movement thereto toward and away from said first permanent magnet for providing a controlled bypass flux path thereabout, and

a second actuator coupled to a second steel inset for imparting a controlled radial movement thereto toward and away from said second permanent magnet for providing a controlled bypass flux path thereabout;

whereby control of the field weakening assembly to drive said first and second steel insets toward the respective sides of said stator promotes a flow of flux around said permanent magnets and reduces a magnetic field in the air gap produced by said permanent magnets, and control of the field weakening assembly to retract said first and second steel insets away from the respective sides of said stator to impede a flow of flux around said permanent magnets and enhances the air gap magnetic field produced by said permanent magnets.

16. The permanent magnet motor of claim 15 wherein said rotor poles are arranged with respect to said stator poles to provide a constant air-gap reluctance during rotation of said rotor within said stator.

17. The permanent magnet motor of claim 16 wherein said stator poles are equally spaced at angular intervals of $\pi/3$ radians.

18. The permanent magnet motor of claim 17 wherein said stator poles have a pole arc of $\pi/6$ radians.

19. The permanent magnet motor of claim 18 wherein said rotor poles are equally spaced at angular intervals of $\pi/2$ radians.

20. The permanent magnet motor of claim 19 wherein said rotor poles have a pole arc equal to or slightly greater than $\pi/6$ radians.

21. A method for controlling the magnetic field from the permanent magnets in a permanent magnet motor having a rotor with a plurality of salient poles spaced at equal angular intervals around a central axis, and a stator having a plurality of salient poles spaced at equal angular intervals around a central axis, said stator poles being arranged with respect to said rotor poles to provide a constant air-gap reluctance during rotation of said rotor within said stator, and a plurality of permanent magnets arranged on diametrically opposite sides of said stator to serve as a source of flux for magnetizing the motor, the method comprising the steps of:

decreasing an air gap magnetic field of said permanent magnets by driving a plurality of steel insets against said stator, each inset providing a controlled bypass flux path around one of said permanent magnets; and

increasing the air gap magnetic field of said permanent magnets by retracting said plurality of steel insets away from said stator, thereby impeding the bypass flux path around said permanent magnets.

22. A permanent magnet motor comprising:
a rotor, said rotor further comprising,
a plurality of salient poles spaced at equal angular intervals around a central axis;
a stator for exciting said rotor to move, said stator further comprising,

a plurality of salient poles spaced at equal angular intervals around a central axis, said stator poles being arranged with respect to said rotor poles to provide a constant air-gap reluctance during rotation of said rotor within said stator, and

a plurality of permanent magnets shaped in parallelepipeds and seated in diametrically opposite sides of said stator to serve as a source of flux for magnetizing the motor, said permanent magnets each further comprising a pair of cooperating magnet sections slidably seated in said stator; and

a plurality of actuators coupled to each of said permanent magnet sections for imparting a controlled axial movement thereto, said permanent magnet sections being selectively driven by said actuators into and out from said stator;

whereby said reaction torque due to said permanent magnets may be increased in accordance with the torque requirements by operating said actuators to axially drive said permanent magnet sections into said stator, and a reaction torque due to said permanent magnets may be decreased in accordance with the torque requirements by operating said actuators to axially extract said permanent magnet sections from said stator.

23. The permanent magnet motor of claim 22 wherein said plurality of permanent magnets further comprises a first permanent magnet and a second permanent magnet parallelly spaced on opposing sides of said rotor axis, said first and second permanent magnets both comprising a pair of magnet sections which may be joined in elongate parallelepipeds, and said plurality of actuators further comprise four actuators each coupled to a corresponding permanent magnet section for imparting a controlled axial movement thereto.

24. The permanent magnet motor of claim 23 wherein said plurality of stator poles further comprises a multiple of six

stator poles evenly spaced at angular intervals equal to a multiple of $\pi/3$ radians.

25. The permanent magnet motor of claim 24 wherein said stator poles have a pole arc equal to a multiple of $\pi/6$ radians.

26. The permanent magnet motor of claim 25 wherein said plurality of rotor poles further comprises a multiple of four rotor poles evenly spaced at angular intervals equal to a multiple of $\pi/2$ radians.

27. The permanent magnet motor of claim 26 wherein said rotor poles have a pole arc equal to a multiple of $\pi/6$ radians.

28. The permanent magnet motor of claim 22 wherein said plurality of stator poles further comprises six stator poles evenly spaced at angular intervals of $\pi/3$ radians.

29. The permanent magnet motor of claim 28 wherein said stator poles have a pole arc equal to $\pi/6$ radians.

30. The permanent magnet motor of claim 29 wherein said plurality of rotor poles further comprises four rotor poles evenly spaced at angular intervals of $\pi/2$ radians.

31. The permanent magnet motor of claim 30 wherein said rotor poles have a pole arc of at least $\pi/6$ radians.

32. A method for controlling the magnetic field from the permanent magnets in a permanent magnet motor having a rotor with a plurality of salient poles spaced at equal angular intervals around a central axis, and a stator having a plurality of salient poles spaced at equal angular intervals around a central axis, said stator poles being arranged with respect to said rotor poles to provide a constant air-gap

reluctance during rotation of said rotor within said stator, and a plurality of permanent magnets axially insertable into diametrically opposite sides of said stator to serve as a source of flux for magnetizing the motor when inserted in said stator, the method comprising the steps of:

increasing the magnetic field of said permanent magnets in accordance with a speed of said motor by axially sliding said permanent magnets into said stator; and

decreasing the magnetic field of said permanent magnets in accordance with the speed of said motor by axially sliding said permanent magnets out from said stator.

33. A permanent magnet motor comprising:

a rotor, said rotor further comprising,

a plurality of salient poles spaced at equal angular intervals around a central axis;

a stator for exciting said rotor to move, said stator further comprising,

a plurality of salient poles spaced at equal angular intervals around a central axis, said stator poles being arranged with respect to said rotor poles to provide a constant air-gap reluctance during rotation of said rotor within said stator, and

a plurality of permanent magnets shaped in parallelepipeds and arranged on diametrically opposite sides of said stator to serve as a source of flux for magnetizing the motor; and

a flux by-pass collar encircling said stator and rotatable thereabout to provide a controlled bypass flux path around said permanent magnets, said flux by-pass collar further comprising a plurality of non-magnetic sections each angularly corresponding to one of said permanent magnets;

whereby the flux by-pass collar may be rotated in accordance with the torque requirements to cause each of said magnetic sections to bridge the corresponding permanent magnet, thereby promoting a flow of flux around said permanent magnet and thereby reducing the air gap magnetic field of said

permanent magnet, and the flux by-pass collar may be rotated in accordance with the torque requirements to displace each of said non-magnetic sections from the corresponding permanent magnet, thereby eliminating a flow of flux around said permanent magnet and reducing a magnetic field of said permanent magnet.

34. The permanent magnet motor of claim 33 wherein said plurality of permanent magnets further comprises a first permanent magnet and a second permanent magnet shaped as elongate parallelepipeds and parallelly spaced on opposing sides of said rotor axis, and said flux by-pass collar further comprises a first non-magnetic section angularly corresponding to said first permanent magnet, a second non-magnetic section angularly corresponding to said second permanent magnet, and a pair of magnetic sections integral to said non-magnetic sections.

35. The permanent magnet motor of claim 33 wherein the non-magnetic sections of said flux by-pass collar are formed with a helical slant.

36. The permanent magnet motor of claim 34 wherein said plurality of stator poles further comprises a multiple of six stator poles evenly spaced at angular intervals equal to a multiple of $\pi/3$ radians.

37. The permanent magnet motor of claim 36 wherein said stator poles have a pole arc equal to a multiple of $\pi/6$ radians.

38. The permanent magnet motor of claim 37 wherein said plurality of rotor poles further comprises a multiple of four rotor poles evenly spaced at angular intervals equal to a multiple of $\pi/2$ radians.

39. The permanent magnet motor of claim 38 wherein said rotor poles have a pole arc equal to a multiple of $\pi/6$ radians.

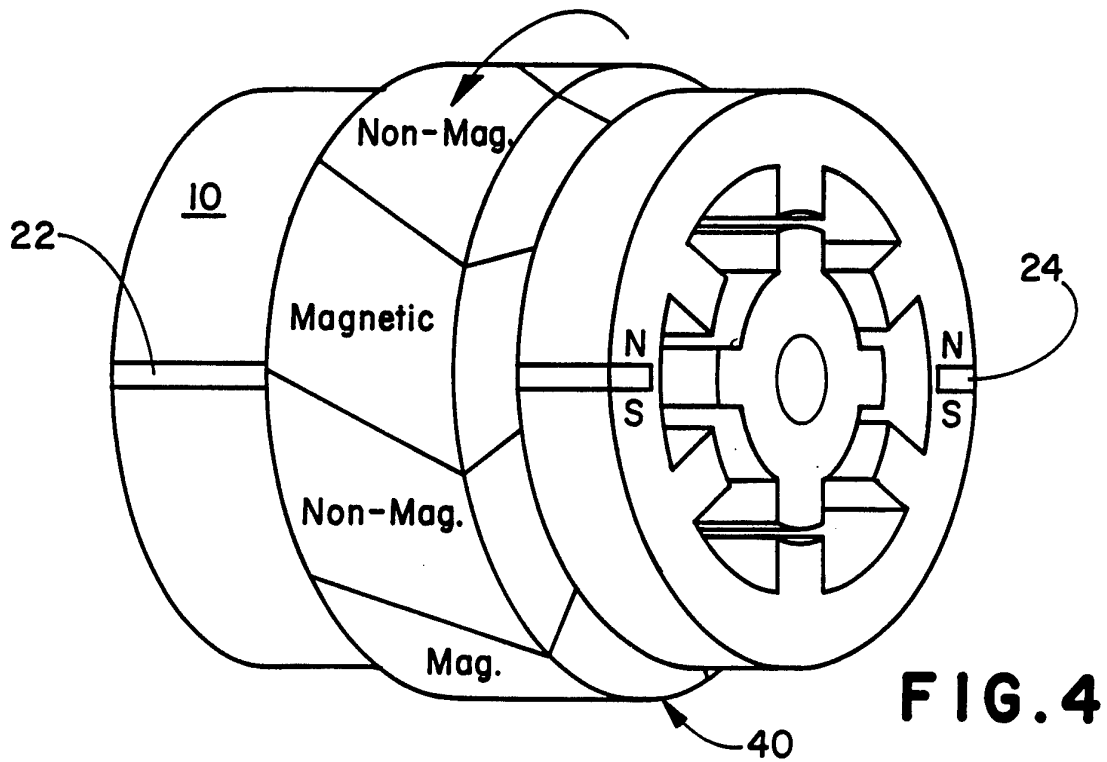
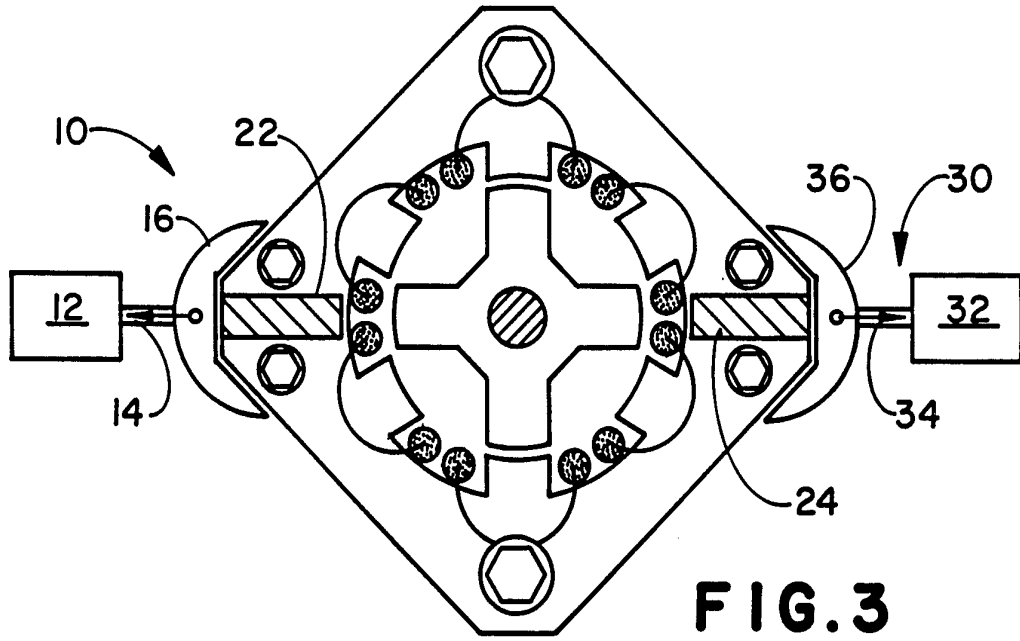

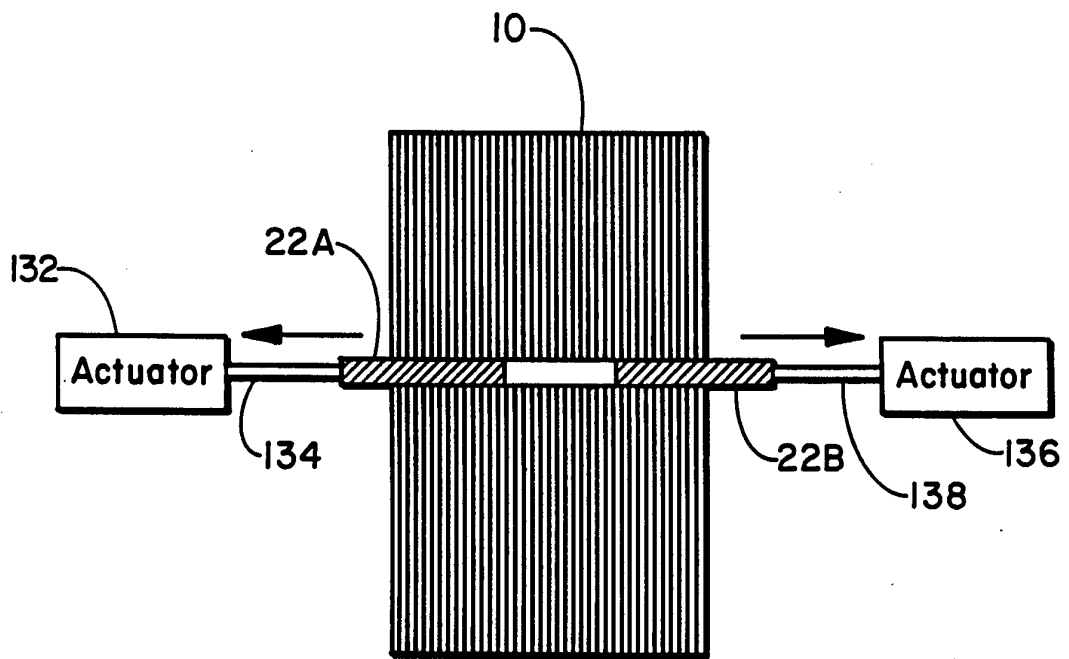
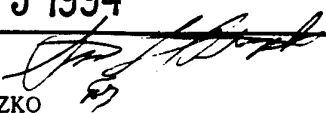



FIG. 5

INTERNATIONAL SEARCH REPORT

International application No.
PCT/US94/01745

A. CLASSIFICATION OF SUBJECT MATTER IPC(5) : H02K 1/17, 37/04, 37/24; H02P 5/28, 7/36 US CL : 310/106, 154, 181; 318/701 According to International Patent Classification (IPC) or to both national classification and IPC		
B. FIELDS SEARCHED Minimum documentation searched (classification system followed by classification symbols) U.S. : 310/49.R, 152, 162, 163, 164, 179, 181, 254, 261, 269 Documentation searched other than minimum documentation to the extent that such documents are included in the fields searched Electronic data base consulted during the international search (name of data base and, where practicable, search terms used) Please See Extra Sheet.		
C. DOCUMENTS CONSIDERED TO BE RELEVANT		
Category*	Citation of document, with indication, where appropriate, of the relevant passages	Relevant to claim No.
A	US, A, 5,117,144 (Torok) 26 May 1992.	1,15,22,33
A	US, A, 5,051,640 (Freise) 24 September 1991.	1,15,22,33
A	US, A, 4,972,112 (Kim) 20 November 1990.	1,15,22,33
A	US, A, 4,896,088 (Jahns) 23 January 1990.	1,15,22,33
A	US, A, 4,348,605 (Torok) 07 September 1982.	1,15,22,33
A	US, A, 4,011,479 (Volkrodt) 08 March 1977.	1,15,22,33
A	US, A, 3,984,711 (Kordik) 05 October 1976.	1,15,22,33
A	US, A, 3,862,445 (Volkrodt) 21 January 1975.	1,15,22,33
<input checked="" type="checkbox"/> Further documents are listed in the continuation of Box C. <input type="checkbox"/> See patent family annex.		
* Special categories of cited documents: *A* document defining the general state of the art which is not considered to be part of particular relevance *E* earlier document published on or after the international filing date *L* document which may throw doubts on priority claim(s) or which is cited to establish the publication date of another citation or other special reason (as specified) *O* document referring to an oral disclosure, use, exhibition or other means *P* document published prior to the international filing date but later than the priority date claimed	*T* later document published after the international filing date or priority date and not in conflict with the application but cited to understand the principle or theory underlying the invention *X* document of particular relevance; the claimed invention cannot be considered novel or cannot be considered to involve an inventive step when the document is taken alone *Y* document of particular relevance; the claimed invention cannot be considered to involve an inventive step when the document is combined with one or more other such documents, such combination being obvious to a person skilled in the art *&* document member of the same patent family	
Date of the actual completion of the international search 24 May 1994	Date of mailing of the international search report JUN 23 1994	
Name and mailing address of the ISA/US Commissioner of Patents and Trademarks Box PCT Washington, D.C. 20231 Facsimile No. NOT APPLICABLE	Authorized officer  DENNIS HASZKO Telephone No. (703) 308-1693 	

INTERNATIONAL SEARCH REPORT

International application No.

PCT/US94/01745

C (Continuation). DOCUMENTS CONSIDERED TO BE RELEVANT

Category*	Citation of document, with indication, where appropriate, of the relevant passages	Relevant to claim No.
A	US, A, 2,816,240 (Zimmerman) 10 December 1957.	1,15,22,33

INTERNATIONAL SEARCH REPORT

International application No.

PCT/US94/01745

B. FIELDS SEARCHED

Electronic data bases consulted (Name of data base and where practicable terms used):

APS:

- s vr or variable reluctance
- s doubl# salient
- s permanent magnet? and stator#
- c lipo, t?/in
- c liao, y?/in
- c liang, f?/in