



- (51) **International Patent Classification:**
H01F 27/14 (2006.01) *F16K 17/196* (2006.01)
- (21) **International Application Number:**
PCT/EP2016/064398
- (22) **International Filing Date:**
22 June 2016 (22.06.2016)
- (25) **Filing Language:** English
- (26) **Publication Language:** English
- (30) **Priority Data:**
15173925.7 25 June 2015 (25.06.2015) EP
- (71) **Applicant:** ABB SCHWEIZ AG [CH/CH]; Brown Boveri Strasse 6, CH-5400 Baden (CH).
- (72) **Inventor:** CARDONA, Julian; Condominio Santa Lucia del Bosque, Casa 19, Santa Rosa de Cabal, Risaralda (CO).
- (74) **Agent:** SAVELA, Reino; ABB AB, Intellectual Property, Ingenjör Bååths Gata 11, 721 83 Västerås (SE).
- (81) **Designated States** (unless otherwise indicated, for every kind of national protection available): AE, AG, AL, AM, AO, AT, AU, AZ, BA, BB, BG, BH, BN, BR, BW, BY, BZ, CA, CH, CL, CN, CO, CR, CU, CZ, DE, DK, DM,

DO, DZ, EC, EE, EG, ES, FI, GB, GD, GE, GH, GM, GT, HN, HR, HU, ID, IL, IN, IR, IS, JP, KE, KG, KN, KP, KR, KZ, LA, LC, LK, LR, LS, LU, LY, MA, MD, ME, MG, MK, MN, MW, MX, MY, MZ, NA, NG, NI, NO, NZ, OM, PA, PE, PG, PH, PL, PT, QA, RO, RS, RU, RW, SA, SC, SD, SE, SG, SK, SL, SM, ST, SV, SY, TH, TJ, TM, TN, TR, TT, TZ, UA, UG, US, UZ, VC, VN, ZA, ZM, ZW.

(84) **Designated States** (unless otherwise indicated, for every kind of regional protection available): ARIPO (BW, GH, GM, KE, LR, LS, MW, MZ, NA, RW, SD, SL, ST, SZ, TZ, UG, ZM, ZW), Eurasian (AM, AZ, BY, KG, KZ, RU, TJ, TM), European (AL, AT, BE, BG, CH, CY, CZ, DE, DK, EE, ES, FI, FR, GB, GR, HR, HU, IE, IS, IT, LT, LU, LV, MC, MK, MT, NL, NO, PL, PT, RO, RS, SE, SI, SK, SM, TR), OAPI (BF, BJ, CF, CG, CI, CM, GA, GN, GQ, GW, KM, ML, MR, NE, SN, TD, TG).

Declarations under Rule 4.17:

- as to the identity of the inventor (Rule 4.17(i))
- of inventorship (Rule 4.17(iv))

Published:

- with international search report (Art. 21(3))

(54) **Title:** TRANSFORMER ARRANGEMENT AND METHOD FOR CONTROLLING PRESSURE IN A LIQUID-FILLED TRANSFORMER

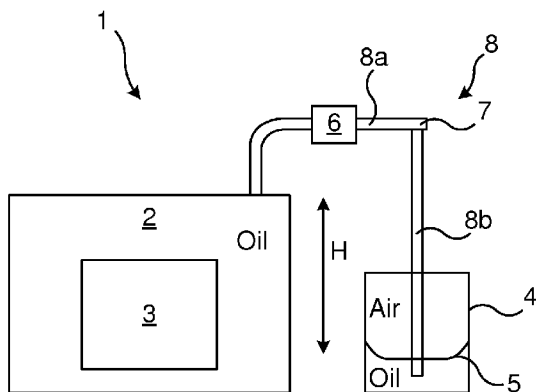

Fig. 1

(57) **Abstract:** The present disclosure relates to a transformer arrangement 1 comprising a transformer tank 2 for a liquid-filled electrical transformer, an expansion tank 4, and piping 8 connecting the transformer tank with the expansion tank for enabling liquid of the liquid-filled transformer to flow between the transformer tank and the expansion tank via the piping. The piping comprises a valve 7. The valve is configured for allowing the liquid to flow from the transformer tank to the expansion tank when the pressure of the liquid in the transformer tank is above a predefined first threshold and for preventing the liquid to flow from the transformer tank to the expansion tank when the pressure of the liquid in the transformer tank is below a predefined second threshold. The valve is also configured for allowing the liquid to flow from the expansion tank to the transformer tank when the pressure of the liquid in the transformer tank is above the predefined second threshold.

WO 2016/207207 A1

TRANSFORMER ARRANGEMENT AND METHOD FOR CONTROLLING PRESSURE IN A LIQUID-FILLED TRANSFORMER

TECHNICAL FIELD

- 5 The present disclosure relates to a liquid-filled transformer comprising a transformer tank, an expansion tank and piping connecting the transformer tank with the expansion tank for enabling liquid of the liquid-filled transformer to flow between the transformer tank and the expansion tank via the piping.

10 **BACKGROUND**

- Oil-immersed transformers provide expansion systems to allow the expansion of the oil due to temperature change. The expansion system shall be sufficient to accommodate the change in liquid volume from the lowest level at coldest ambient temperature when the transformer is de-energized,
15 to the highest level when the transformer is full loaded at maximum ambient temperature.

- According to the international standards International Electrotechnical Commission (IEC) standard 60076-1 and Institute of Electrical and Electronics Engineers (IEEE) standard C57.12.00, there are the following
20 types of liquid preservation system:

1. Freely breathing system or conservator system where there is free communication between the ambient air and an air-filled expansion space above the surface of the liquid, in the tank or in a separate expansion vessel (conservator). A moisture-removing breather is fitted in the connection to the
25 atmosphere.
2. Diaphragm or bladder-type liquid preservation system where an expansion volume of air at atmospheric pressure is provided above the liquid but prevented from direct contact with the liquid by a flexible diaphragm or

bladder. A moisture-removing breather is fitted in the connection to the atmosphere.

3. Inert gas pressure system where an expansion space above the liquid is filled with dry inert gas at slight over-pressure, being connected to either a
5 pressure controlled source or an elastic bladder.

4. Sealed-tank system with gas cushion, in which a volume of gas above the liquid surface in a stiff tank accommodates the liquid expansion under variable pressure.

5. Sealed, completely filled system in which the expansion of the liquid is
10 taken up by elastic movement of the permanently sealed, usually corrugated tank or radiators.

In order to utilize the gravitational force, the expansion vessel (e.g. a conservator), if used, is positioned above the transformer tank.

SUMMARY

15 It has been realized that the configuration with an expansion vessel/tank above the transformer tank has several problems, some of which are listed below:

1. The total size of the transformer arrangement is increased.

2. Many parts are required for assembly of the expansion tank, which may be
20 a problem in seismically active geographical locations.

3. Maintenance and the assembly are risky and expensive due to the expansion tank being positioned high above ground and above the transformer tank.

4. It is time consuming to assemble and disassemble the transformer
25 arrangement in the factory and on site.

5. High transport costs due to many separate parts. The expansion tank and supports are now shipped as separate pieces. with new method the expansion tank can be attached at the main tank and shipped all parts as only one piece.

Thus, it is an objective of the present invention to provide a solution to at
5 least some of these problems relating to prior art transformer assemblies.

According to an aspect of the present invention, there is provided a transformer arrangement comprising a transformer tank for a liquid-filled electrical transformer, an expansion tank, and piping connecting the transformer tank with the expansion tank for enabling liquid of the liquid-
10 filled transformer to flow between the transformer tank and the expansion tank via the piping. The piping comprises a valve. The valve is configured for allowing the liquid to flow from the transformer tank to the expansion tank when the pressure of the liquid in the transformer tank is above a predefined first threshold and for preventing the liquid to flow from the transformer
15 tank to the expansion tank when the pressure of the liquid in the transformer tank is below the predefined first threshold. The valve is also configured for allowing the liquid to flow from the expansion tank to the transformer tank when the pressure of the liquid in the transformer tank is below a predefined second threshold and for preventing the liquid to flow from the expansion
20 tank to the transformer tank when the pressure of the liquid in the transformer tank is above the predefined second threshold.

According to an aspect of the present invention, there is provided a method performed in a transformer arrangement comprising a liquid-filled transformer tank and an expansion tank. The method comprises
25 allowing the liquid to flow from the transformer tank to the expansion tank via piping, when the pressure of the liquid in the transformer tank is above a predefined first threshold by automatically opening a valve of the piping. The method also comprises preventing the liquid to flow from the transformer tank to the expansion tank when the pressure of the liquid in the
30 transformer tank is below the predefined first threshold by automatically

closing the valve. The method also comprises allowing the liquid to flow from the expansion tank to the transformer tank when the pressure of the liquid in the transformer tank is below a predefined second threshold, lower than the first threshold, by automatically opening the valve.

- 5 By means of the valve which can automatically close and open in response to the varying pressure in the transformer tank, the pressure in the transformer tank can be controlled and the flow between the transformer tank and the expansion tank be handled without the need for positioning the expansion tank above the transformer tank. For instance, both the transformer tank and
- 10 the expansion tank may be positioned on the ground or floor where the expansion tank may be easily accessible to maintenance personnel etc. In order to allow liquid flow from the expansion tank to the transformer tank, the piping typically extends down into the liquid phase of the expansion tank since otherwise gas (e.g. air), not liquid, may be sucked into the piping. The
- 15 liquid may be any suitable transformer liquid, i.e. electrically insulating and suitable for the operating temperature of the transformer such as an ester liquid or an oil e.g. a mineral oil. The transformer may be any type of transformer but is typically rather bulky, e.g. a high-voltage transformer. With the expansion tank positioned next to the transformer tank, the
- 20 expansion tank can be attached at the main tank and shipped together, reducing the number of parts and facilitating assembly.

The method may be performed by means of the transformer arrangement of the present invention.

- 25 It is to be noted that any feature of any of the aspects may be applied to any other aspect, wherever appropriate. Likewise, any advantage of any of the aspects may apply to any of the other aspects. Other objectives, features and advantages of the enclosed embodiments will be apparent from the following detailed disclosure, from the attached dependent claims as well as from the drawings.

Generally, all terms used in the claims are to be interpreted according to their ordinary meaning in the technical field, unless explicitly defined otherwise herein. All references to "a/an/the element, apparatus, component, means, step, etc." are to be interpreted openly as referring to at least one instance of the element, apparatus, component, means, step, etc., unless explicitly stated otherwise. The steps of any method disclosed herein do not have to be performed in the exact order disclosed, unless explicitly stated. The use of "first", "second" etc. for different features/components of the present disclosure are only intended to distinguish the features/components from other similar features/components and not to impart any order or hierarchy to the features/components.

BRIEF DESCRIPTION OF THE DRAWINGS

Embodiments will be described, by way of example, with reference to the accompanying drawings, in which:

15 Fig 1 is a schematic diagram in section, illustrating an embodiment of a transformer arrangement of the present invention.

Fig 2 is a schematic sectional view of an embodiment of a valve in accordance with the present invention.

20 Fig. 3a is a schematic sectional view of a part of the piping comprising the valve in accordance with an embodiment of the present invention.

Fig. 3b is another schematic sectional view of a part of the piping comprising the valve in accordance with an embodiment of the present invention.

Fig. 3c is another schematic sectional view of a part of the piping comprising the valve in accordance with an embodiment of the present invention.

25 Fig. 3d is another schematic sectional view of a part of the piping comprising the valve in accordance with an embodiment of the present invention.

Fig. 3e is another schematic sectional view of a part of the piping comprising the valve in accordance with an embodiment of the present invention.

DETAILED DESCRIPTION

Embodiments will now be described more fully hereinafter with reference to the accompanying drawings, in which certain embodiments are shown.

However, other embodiments in many different forms are possible within the scope of the present disclosure. Rather, the following embodiments are provided by way of example so that this disclosure will be thorough and complete, and will fully convey the scope of the disclosure to those skilled in the art. Like numbers refer to like elements throughout the description.

Figure 1 is a schematic diagram in section, illustrating an embodiment of a transformer arrangement 1 of the present invention. Since the present invention is concerned with the liquid handling, and not the electric components of the transformer, such electric components are not shown in the figure. The active parts of the transformer, such as core and windings are schematically illustrated as reference number 3 within the transformer tank 2 and will not be further discussed herein. The transformer tank is liquid-filled (typically completely liquid-filled, substantially without a gas phase), in this case with oil. Piping 8 connects the transformer tank 2 to an expansion tank 4 (e.g. a conservator), forming a conduit for the oil to flow between the tanks 2 and 4. The piping 8 comprises a valve 7 between a first pipe 8a connecting the valve to the transformer tank and a second pipe 8b connecting the valve to the expansion tank 4. A Buchholz relay 6 or other safety valve may be included with the first pipe 8a between the valve 7 and the transformer tank 2. The second pipe 8b extends below the surface of the oil phase in the expansion tank, to avoid sucking in gas phase (e.g. air) into the transformer tank via the valve 7. By means of the valve, the surface of the oil phase in the expansion tank may be below the surface of the oil in the transformer tank (i.e. the interface between the oil and the tank ceiling, as indicated by the double-headed arrow H. It may be advantageous to avoid direct contact between the oil phase and any gas phase in the expansion tank 4, in order to avoid gas to dissolve in the oil or otherwise enable gas to follow the oil into the transformer tank 2, why a diaphragm 5 or the like (e.g. a rubber film) is used. Thus, the upper surface of the oil phase in the expansion tank may be

an interphase between the oil and the diaphragm, without any need for applying an over pressure in the expansion tank to induce a flow from the expansion tank to the transformer tank (although the invention could alternatively be used together with such applied over pressure, e.g. by means
5 of a compressor or a pressurized gas source, depending on the values of the first and second thresholds).

Figure 2 is a schematic sectional view of an embodiment of the valve 7 in accordance with the present invention. The valve is arranged as part of the piping 8, connecting the first and second pipes 8a and 8b to each other. At
10 the valve, the first and second pipes may be arranged at an angle to each other to allow the preferred design of the valve 7 with will be discussed in the following. However, it is noted that other designs of the valve may alternatively be used to achieve the functionality of the valve in accordance with the present invention. The valve 7 may comprise two different valve
15 parts, a first valve part for opening the valve when the liquid pressure in the transformer tank is above the first threshold (typically above ambient pressure, e.g. above atmospheric pressure), and a second valve part for opening the valve when the liquid pressure in the transformer tank is below the second threshold (typically below ambient pressure, e.g. below
20 atmospheric pressure), the second threshold being different from the first threshold such that the valve is closed when the pressure in the transformer tank is between the first and second thresholds. The first and second valve parts may be separate, but may preferably be integrated with each other in the valve. In the example of the figure, the first valve part comprises an over
25 pressure spring, e.g. a spiral spring, 21 which may be compressed to open the valve by an over pressure in the transformer tank (and thus in the first pipe 8a) above the first threshold. The second part may comprise a vacuum spring/valve, e.g. positioned within the spiral spring of the over pressure spring 21 (as shown in the figure). The vacuum spring is configured for
30 release (the sealing part of the vacuum spring being pushed into the first pipe 8a), thereby opening the valve, when the pressure in the transformer tank (and thus in the first pipe 8a) is below the second threshold. The valve may

comprise a first flange for connecting the valve to the first pipe 8a, as well as a second flange 24 for connecting the valve to the second pipe 8b. A sealing gasket 23 may be provided for sealingly engaging with the sealing part of the vacuum spring when the vacuum spring has not released to open the valve.

- 5 With reference to figures 3a-e, the functionality of the valve 7 will now be discussed depending on varying pressure in the transformer tank 2.

In the situation of figure 3a, the temperature, and thus the pressure, is slightly elevated (e.g. a bit, but not a lot, over atmospheric pressure) as indicated by the single upward pointing arrows. The over pressure is not
10 enough to overcome the force of the over pressure spring 21, why the valve 7 remains closed and no liquid is flowing through the piping 8.

In the situation of figure 3b, the temperature, and thus the pressure, is substantially more elevated (e.g. a lot over atmospheric pressure) as indicated by the triplets of upward pointing arrows. The over pressure is
15 enough to overcome the force of the over pressure spring 21, why the valve 7 is pushed open allowing liquid to flow through the piping 8 into the expansion tank 4. As can be seen in the figure, the vacuum spring 22, within the over pressure spring 22, is still closed but since the over pressure spring moves also the whole vacuum spring, the valve is opened regardless.

- 20 In the situation of figure 3c, the temperature, and thus the pressure, has returned to being only slightly elevated (e.g. a bit, but not a lot, over atmospheric pressure) as indicated by the single upward pointing arrows. The over pressure is no longer enough to overcome the force of the over pressure spring 21, why the valve 7 returns to its closed position and no liquid
25 is flowing through the piping 8.

In the situation of figure 3d, the temperature, and thus the pressure, has fallen further, to be slightly reduced (e.g. a bit, but not a lot, below atmospheric pressure) as indicated by the single downward pointing arrows. The under pressure is not enough to overcome the force of the vacuum spring

22, why the valve 7 remains closed and no liquid is flowing through the piping 8.

In the situation of figure 3e, the temperature, and thus the pressure, has been further reduced (e.g. substantially below atmospheric pressure, but the under
5 pressure is not necessarily as high as the over pressure needed to open the valve by means of the over pressure spring 21) as indicated by the downward pointing arrow pairs. The under pressure is enough to overcome the force of the vacuum spring 22 (releasing it such that its sealing part is pulled and
10 moved towards the transformer tank 2), why the valve 7 is opened and liquid is flowing through the piping 8 from the expansion tank 4.

In some embodiments of the present invention, the expansion tank 4 is positioned relative to the transformer tank 2 such as to allow a top surface of the liquid in the expansion tank to be lower than a top surface of the liquid in the transformer tank.

15 In some embodiments of the present invention, the valve 7 comprises an overpressure spring 21 for allowing the liquid to flow from the transformer tank 2 to the expansion tank 4 when the pressure of the liquid in the transformer tank is above the predefined first threshold and for preventing
20 the liquid to flow from the transformer tank to the expansion tank when the pressure of the liquid in the transformer tank is below the predefined first threshold.

In some embodiments of the present invention, the valve 7 comprises a vacuum spring 22 for allowing the liquid to flow from the expansion tank 4 to the transformer tank 2 when the pressure of the liquid in the transformer
25 tank is below the predefined second threshold and for preventing the liquid to flow from the expansion tank to the transformer tank when the pressure of the liquid in the transformer tank is above the predefined second threshold.

In some embodiments of the present invention, the piping further comprises a Buchholz relay 6 between the transformer tank 2 and the
30 valve 7.

In some embodiments of the present invention, the expansion tank 4 comprises a diaphragm for separating the liquid from a gas phase in the expansion tank.

Embodiments of the present invention may convey at least some of the following advantages:

- Improvement of safety conditions.
- Reduction of design time and manufacturing time.
- Less slender and high structure, giving a more compact design..
- The expansion tank 4 may be integrated as a structural element of the transformer tank 2.
- The total size of the transformer arrangement 1 is reduced.
- Reduction of time for assembly in factory as well as time for assembly on site.
- Reduction of transportation cost since less bulky design.
- Total cost of the transformer arrangement is reduced.

The present disclosure has mainly been described above with reference to a few embodiments. However, as is readily appreciated by a person skilled in the art, other embodiments than the ones disclosed above are equally possible within the scope of the present disclosure, as defined by the appended claims.

CLAIMS

1. A transformer arrangement (1) comprising:

a transformer tank (2) for a liquid-filled electrical transformer;

an expansion tank (4); and

5 piping (8), connecting the transformer tank with the expansion tank for enabling liquid of the liquid-filled transformer to flow between the transformer tank and the expansion tank via the piping, the piping comprising a valve (7);

wherein the valve is configured for allowing the liquid to flow from the
10 transformer tank to the expansion tank when the pressure of the liquid in the transformer tank is above a predefined first threshold and for preventing the liquid to flow from the transformer tank to the expansion tank when the pressure of the liquid in the transformer tank is below the predefined first threshold;

15 wherein the valve is configured for allowing the liquid to flow from the expansion tank to the transformer tank when the pressure of the liquid in the transformer tank is below a predefined second threshold and for preventing the liquid to flow from the expansion tank to the transformer tank when the pressure of the liquid in the transformer tank is above the predefined second
20 threshold; and

wherein the expansion tank (4) is positioned relative to the transformer tank (2) such as to allow a top surface of the liquid in the expansion tank to be lower than a top surface of the liquid in the transformer tank.

2. The transformer arrangement of claim 1, wherein the valve (7)
25 comprises an overpressure spring (21) for allowing the liquid to flow from the transformer tank (2) to the expansion tank (4) when the pressure of the liquid in the transformer tank is above the predefined first threshold and for preventing the liquid to flow from the transformer tank to the expansion tank

when the pressure of the liquid in the transformer tank is below the predefined first threshold.

3. The transformer arrangement of any preceding claim, wherein the valve (7) comprises a vacuum spring (22) for allowing the liquid to flow from the expansion tank (4) to the transformer tank (2) when the pressure of the liquid in the transformer tank is below the predefined second threshold and for preventing the liquid to flow from the expansion tank to the transformer tank when the pressure of the liquid in the transformer tank is above the predefined second threshold.
4. The transformer arrangement of any preceding claim, wherein the piping further comprises a Buchholz relay (6) between the transformer tank (2) and the valve (7).
5. The transformer arrangement of any preceding claim, wherein the expansion tank (4) comprises a diaphragm for separating the liquid from a gas phase in the expansion tank.
6. A method performed in a transformer arrangement (1) comprising a liquid-filled transformer tank (2) and an expansion tank (4), wherein the expansion tank (4) is positioned relative to the transformer tank (2) such that a top surface of the liquid in the expansion tank is lower than a top surface of the liquid in the transformer tank, the method comprising:
 - allowing the liquid to flow from the transformer tank to the expansion tank via piping (8), when the pressure of the liquid in the transformer tank is above a predefined first threshold by automatically opening a valve (7) of the piping;
 - preventing the liquid to flow from the transformer tank to the expansion tank when the pressure of the liquid in the transformer tank is below the predefined first threshold by automatically closing the valve; and

allowing the liquid to flow from the expansion tank to the transformer tank when the pressure of the liquid in the transformer tank is below a predefined second threshold, lower than the first threshold, by automatically opening the valve.

- 5 7. The method of claim 6, wherein the first threshold is above ambient pressure, e.g. atmospheric pressure, and the second threshold is below ambient pressure.

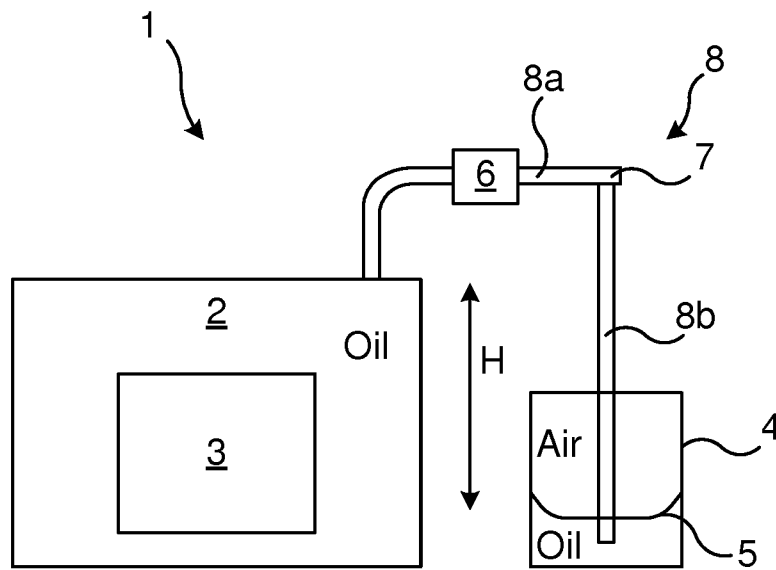

Fig. 1

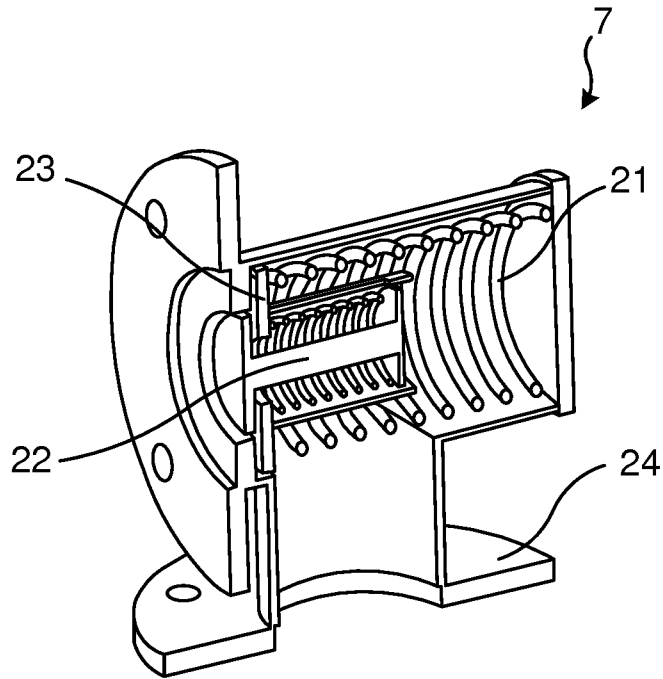

Fig. 2

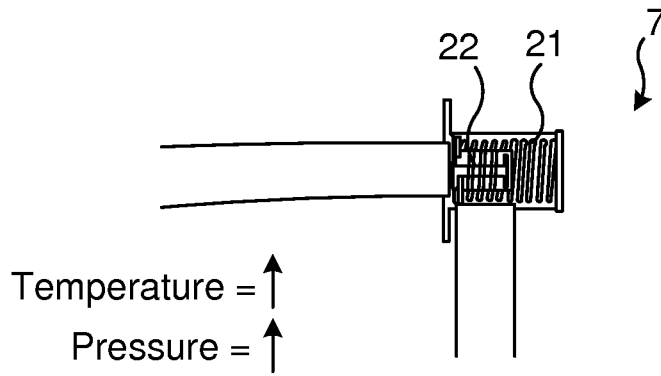

Fig. 3a

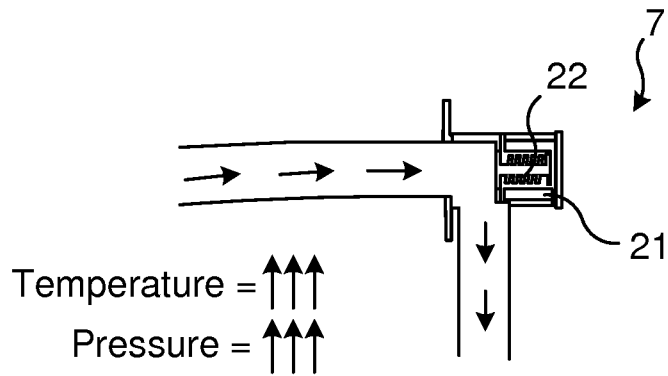

Fig. 3b

3/3

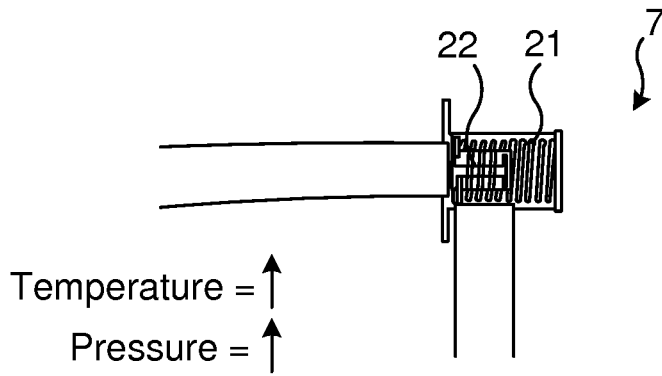

Fig. 3c

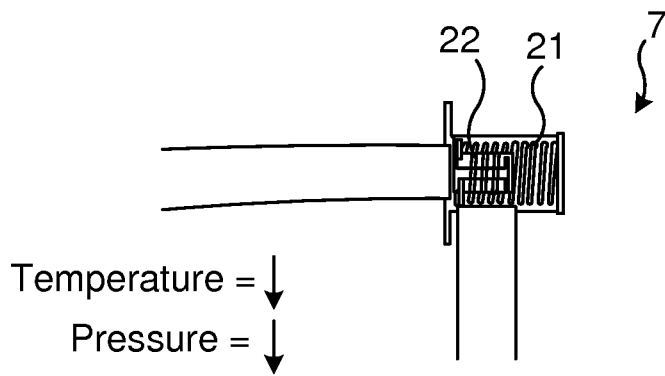

Fig. 3d

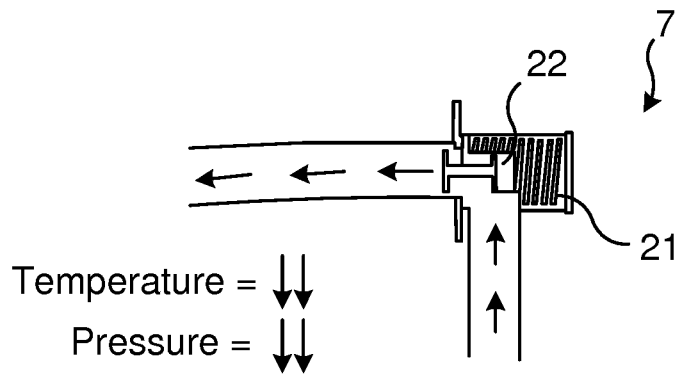

Fig. 3e

INTERNATIONAL SEARCH REPORT

International application No
PCT/EP2016/064398

A. CLASSIFICATION OF SUBJECT MATTER
INV. H01F27/14
ADD. F16K17/196

According to International Patent Classification (IPC) or to both national classification and IPC

B. FIELDS SEARCHED

Minimum documentation searched (classification system followed by classification symbols)
H01F F16K

Documentation searched other than minimum documentation to the extent that such documents are included in the fields searched

Electronic data base consulted during the international search (name of data base and, where practicable, search terms used)
EPO-Internal, WPI Data

C. DOCUMENTS CONSIDERED TO BE RELEVANT

Category*	Citation of document, with indication, where appropriate, of the relevant passages	Relevant to claim No.
A	US 1 860 511 A (NICHOLS LOUIS C) 31 May 1932 (1932-05-31) page 1, line 48 - page 2, line 35; figures 1,2	1-7
A	----- US 4 145 679 A (MITCHELL JR GEORGE F) 20 March 1979 (1979-03-20) column 6, line 13 - column 7, line 26; figure 1	1-7
A	----- FR 84 247 E (ALSTHOM CGEE) 24 December 1964 (1964-12-24) page 1, line 63 - page 2, line 32; figures 1,2	2
	----- -/--	

Further documents are listed in the continuation of Box C.

See patent family annex.

* Special categories of cited documents :

"A" document defining the general state of the art which is not considered to be of particular relevance

"E" earlier application or patent but published on or after the international filing date

"L" document which may throw doubts on priority claim(s) or which is cited to establish the publication date of another citation or other special reason (as specified)

"O" document referring to an oral disclosure, use, exhibition or other means

"P" document published prior to the international filing date but later than the priority date claimed

"T" later document published after the international filing date or priority date and not in conflict with the application but cited to understand the principle or theory underlying the invention

"X" document of particular relevance; the claimed invention cannot be considered novel or cannot be considered to involve an inventive step when the document is taken alone

"Y" document of particular relevance; the claimed invention cannot be considered to involve an inventive step when the document is combined with one or more other such documents, such combination being obvious to a person skilled in the art

"&" document member of the same patent family

Date of the actual completion of the international search	Date of mailing of the international search report
8 September 2016	23/09/2016

Name and mailing address of the ISA/ European Patent Office, P.B. 5818 Patentlaan 2 NL - 2280 HV Rijswijk Tel. (+31-70) 340-2040, Fax: (+31-70) 340-3016	Authorized officer Warneck, Nicolas
--	--

INTERNATIONAL SEARCH REPORT

International application No
PCT/EP2016/064398

C(Continuation). DOCUMENTS CONSIDERED TO BE RELEVANT		
Category*	Citation of document, with indication, where appropriate, of the relevant passages	Relevant to claim No.
A	US 5 282 492 A (ANGELI ROBERT J [US]) 1 February 1994 (1994-02-01) abstract column 4, line 33 - column 5, line 16; figures 3,4 -----	3,4
A	US 2 989 073 A (GOODWIN HARRIS A) 20 June 1961 (1961-06-20) column 1, line 9 - line 45 column 2, line 15 - column 3, line 75; figure 2 -----	5,6
A	US 2 844 165 A (FRANCIS MORSE) 22 July 1958 (1958-07-22) column 1, line 15 - line 26; figure 1 -----	5,6
A	GB 209 053 A (VICKERS ELECTRICAL CO LTD) 19 June 1924 (1924-06-19) page 2, line 16 - line 122 -----	1-7

INTERNATIONAL SEARCH REPORT

Information on patent family members

International application No

PCT/EP2016/064398

Patent document cited in search report	Publication date	Patent family member(s)	Publication date
US 1860511	A	31-05-1932	NONE

US 4145679	A	20-03-1979	CA 1098187 A 24-03-1981
			DE 2807809 A1 24-08-1978
			FR 2382080 A1 22-09-1978
			GB 1563791 A 02-04-1980
			IT 1104430 B 21-10-1985
			US 4145679 A 20-03-1979

FR 84247	E	24-12-1964	NONE

US 5282492	A	01-02-1994	NONE

US 2989073	A	20-06-1961	NONE

US 2844165	A	22-07-1958	NONE

GB 209053	A	19-06-1924	NONE
