

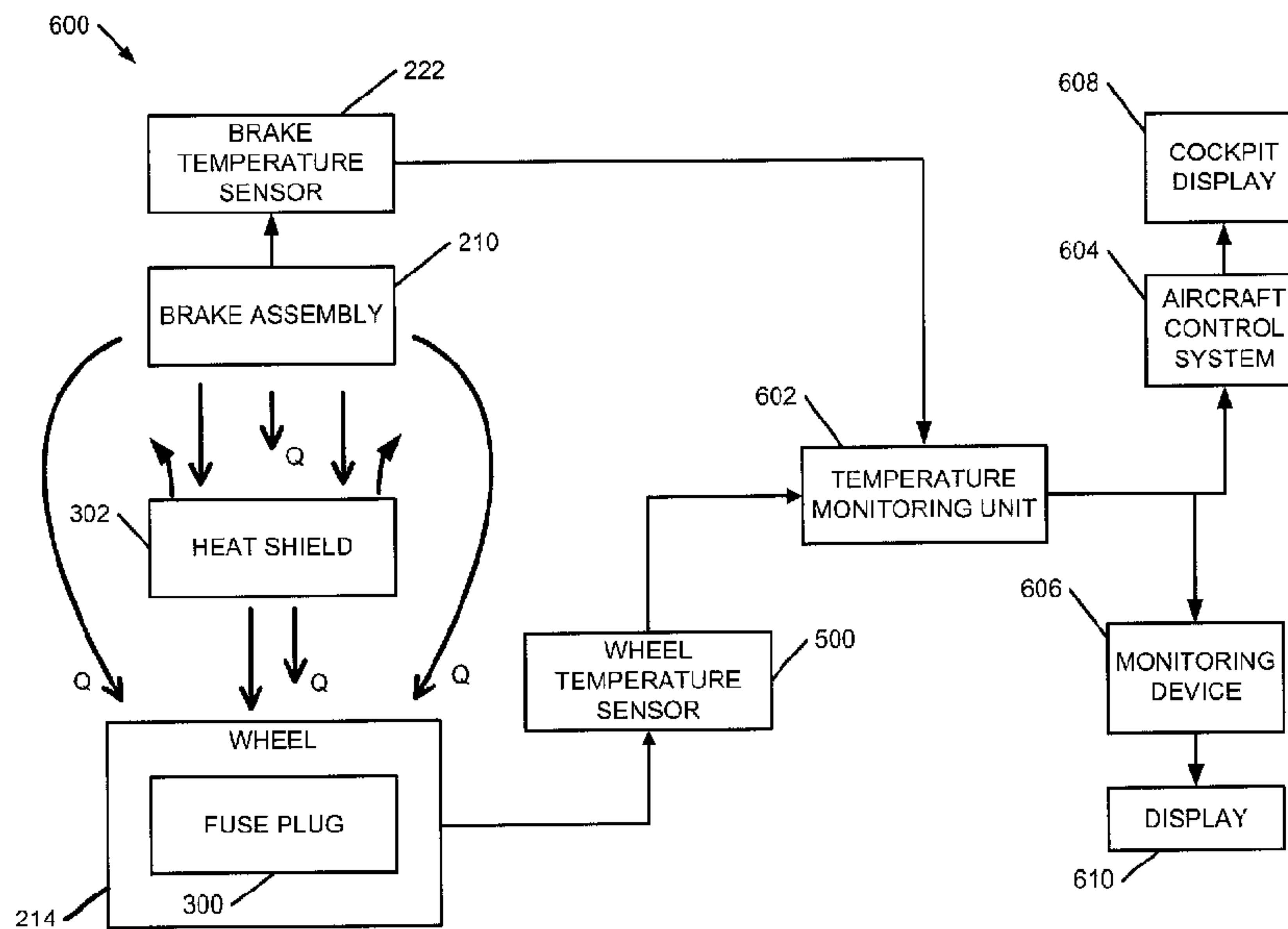

(22) Date de dépôt/Filing Date: 2014/09/24
 (41) Mise à la disp. pub./Open to Public Insp.: 2015/05/22
 (45) Date de délivrance/Issue Date: 2018/03/06
 (30) Priorité/Priority: 2013/11/22 (US14/088,087)

(51) Cl.Int./Int.Cl. *B64D 47/00* (2006.01),
B60C 23/20 (2006.01), *B64C 25/34* (2006.01),
B64C 25/42 (2006.01), *F16D 66/00* (2006.01)
 (72) Inventeur/Inventor:
 MARTIN, CASANDRA JOLENE, US
 (73) Propriétaire/Owner:
 THE BOEING COMPANY, US
 (74) Agent: SMART & BIGGAR

(54) Titre : PROCÉDES POUR SURVEILLER DES COMPOSANTS D'UN SYSTÈME D'ATERRISSAGE D'AVION
 (54) Title: METHODS TO MONITOR COMPONENTS OF AN AIRCRAFT LANDING SYSTEM



(57) **Abrégé/Abstract:**

Methods to monitor components of an aircraft landing system are disclosed herein. An example method includes determining a brake assembly temperature and determining a wheel temperature. The example method also includes retrieving an estimated increase in the wheel temperature from a data structure based on the wheel temperature and the brake assembly temperature. The example method further includes determining a maximum wheel temperature based on the wheel temperature and the estimated increase in the wheel temperature.

ABSTRACT

Methods to monitor components of an aircraft landing system are disclosed herein. An example method includes determining a brake assembly temperature and determining a wheel temperature. The example method also includes retrieving an estimated increase in the wheel temperature from a data structure based on the wheel temperature and the brake assembly temperature. The example method further includes determining a maximum wheel temperature based on the wheel temperature and the estimated increase in the wheel temperature.

METHODS TO MONITOR COMPONENTS OF AN AIRCRAFT LANDING SYSTEM

FIELD

[0001] The present disclosure relates generally to aircraft landing systems and, more particularly, to methods to monitor components of an aircraft landing system.

BACKGROUND

[0002] Generally, an aircraft includes wheels and brakes to facilitate taxiing, landing, parking, etc. When the brakes are operated, the brakes generate heat. The heat from the brakes may be transferred to the wheels. Generally, each of the wheels includes one or more fuse plugs. A fuse plug may include a seal, which melts upon reaching a threshold temperature to release air from a tire on the wheel. Conventional brake temperature monitoring systems utilize only brake temperature measurements, which may not correlate to wheel temperatures in most instances due to heat shielding. These conventional systems also do not address a concern among operators of triggering wheel fuse plugs due to exceeding predetermined temperature thresholds of a wheel. As a result, an operator may subject themselves to overly conservative delay periods to compensate for insufficient data regarding actual wheel temperature. It would therefore be beneficial to provide an enhanced measurement of an existing wheel temperature and predict a future wheel temperature given a particular delay period and eventual landing.

SUMMARY

[0003] An example method includes determining a first temperature of a wheel of an aircraft, and determining a second temperature of a brake assembly operatively coupled to the wheel. The example method further includes associating the first temperature with one of a plurality of

predetermined ranges of wheel temperatures, and associating the second temperature with one of a plurality of predetermined ranges of brake assembly temperatures. The example method also includes determining an estimated increase in the first temperature associated with the one of the ranges of wheel temperatures and the one of the ranges of brake assembly
5 temperatures. The example method also includes determining a maximum temperature of the wheel based on the first temperature and the estimated increase in the first temperature.

[0004] Another example method includes determining a brake assembly temperature and determining a wheel temperature. The example method also includes retrieving an estimated increase in the wheel temperature from a data structure based on the wheel temperature and
10 the brake assembly temperature. The example method further includes determining a maximum wheel temperature based on the wheel temperature and the estimated increase in the wheel temperature.

[0005] Another example method disclosed herein includes determining a brake assembly temperature and determining a wheel temperature. The example method also includes
15 determining if a fuse plug disposed on a wheel is at risk of melting based on the brake assembly temperature, the wheel temperature, and estimated heating patterns of the wheel.

[0005a] Another example method disclosed herein is a method of determining if a fuse plug disposed on a wheel is at risk of melting. The example method includes: determining a brake assembly temperature of a brake assembly operatively coupled to the wheel; determining a
20 wheel temperature of the wheel; determining an estimated maximum temperature of the wheel based on the brake assembly temperature, the wheel temperature, and estimated heating patterns of the wheel; and determining if the estimated maximum temperature of the wheel is greater than a predetermined threshold temperature.

[0005b] Another example method disclosed herein includes: determining a temperature of a
25 wheel of an aircraft; determining a temperature of a brake assembly operatively coupled to the wheel; determining an estimated increase in wheel temperature based on the temperature of the wheel and the temperature of the brake assembly; and determining a maximum temperature of the wheel based on the temperature of the wheel and the estimated increase in wheel temperature.

[0005c] Another example disclosed herein is at least one computer-readable medium comprising codes stored thereon that, when executed by at least one computer, cause the at least one computer to implement any one of the methods.

[0005d] Another example disclosed herein is a fuse plug monitoring system comprising: a
5 wheel temperature sensor disposed on a wheel; a brake temperature sensor disposed on a brake
assembly operationally coupled to the wheel; and a temperature monitoring unit in
communication with the brake temperature sensor and the wheel temperature sensor. The
temperature monitoring unit is configured to: determine an estimated increase in wheel
10 temperature on the basis of a wheel temperature communicated by the wheel temperature
sensor and a brake temperature communicated by the brake temperature sensor; and determine
a maximum temperature of the wheel based on the wheel temperature and the estimated
increase in wheel temperature.

[0006] The features and functions that have been discussed can be achieved independently
in various examples or may be combined in yet other examples further details of which can be
15 seen with reference to the following description and drawings.

BRIEF DESCRIPTION OF THE DRAWINGS

[0007] FIG. 1 illustrates an example aircraft that may be used to implement example
methods disclosed herein.

[0008] FIG. 2 illustrates an example aircraft landing system of the aircraft of FIG. 1.

[0009] FIG. 3 illustrates an example wheel assembly of the aircraft landing system of FIG. 2.

[0010] FIG. 4 illustrates a tire inflation valve disposed on the example wheel assembly of FIG. 3.

[0011] FIG. 5 is a cross-sectional view of the example tire inflation valve of FIG. 4.

[0012] FIG. 6 is a block diagram of an example fuse plug monitoring system including an example temperature monitoring unit.

[0013] FIG. 7 is an example data structure, which may be used to determine an estimated increase in a temperature of a wheel of the example aircraft landing system of FIGS. 1-2.

[0014] FIG. 8 is a graph illustrating wheel temperatures and brake assembly temperatures over a time period in which a plurality of braking events occurs.

[0015] FIG. 9 is a flow diagram of an example method disclosed herein.

[0016] FIGS. 10-11 are flow diagrams of another example method disclosed herein.

[0017] FIG. 12 is a block diagram of an example processing platform capable of executing machine readable instructions to implement the example temperature monitoring unit of FIG. 6.

[0018] Wherever possible, the same reference numbers will be used throughout the drawing(s) and accompanying written description to refer to the same or like parts. As used in this disclosure, stating that any part (e.g., a layer, film, area, or plate) is in any way positioned on (e.g., positioned on, located on, disposed on, or formed on, etc.) another part, means that the referenced part is either in contact with the other part, or that the referenced part is above the other part with one or more intermediate part(s) located therebetween. Stating that any part is in contact with another part means that there is no intermediate part between the two parts.

DESCRIPTION

[0019] Methods to monitor components of an aircraft landing system are disclosed herein. During a braking event of an aircraft such as, for example, landing, taxiing, parking, etc., heat is generated by components (e.g., rotors and stators) of a brake assembly. Heat is transferred from the brake assembly to a wheel operatively coupled to the brake assembly. The wheel may include a fuse plug, which includes a seal that melts at a threshold temperature. If the seal melts, air is released from a tire on the wheel. After one braking event or a plurality of braking events in a given period of time, a temperature of the fuse plug may increase toward the threshold temperature. The examples disclosed herein may be used to monitor a temperature of the brake assembly and/or the wheel to enable an operator of the aircraft, an aircraft control system, etc. to determine when to schedule future braking events (e.g., landing at a destination) or perform one or more actions to cool the brake assembly and/or the wheel to prevent the fuse plug from melting.

[0020] Heat from the brake assembly may be transferred to the fuse plug during the braking event (e.g., as the brakes are applied during landing) and after the braking event (e.g., during taxiing, once the aircraft is parked, etc.). Thus, a temperature of the fuse plug may continue to increase following the braking event. In some examples, a fuse plug monitoring system includes a temperature monitoring unit in communication with a first temperature sensor disposed on the wheel and a second temperature sensor disposed on the brake assembly. The first temperature sensor is used to determine wheel temperatures, and the second temperature sensor is used to determine brake assembly temperatures. In some examples, the temperature monitoring unit

determines an estimated maximum temperature of the wheel and/or the fuse plug based on experimentally determined data associated with a wheel temperature and a brake assembly temperature. In some examples, the estimated maximum temperature of the wheel and/or the fuse plug is an estimated future temperature of the wheel and/or the fuse plug. In some examples, the temperature monitoring unit retrieves an estimated increase in wheel temperature from a data structure such as, for example, a table to determine the estimated maximum wheel temperature.

[0021] FIG. 1 illustrates an example aircraft **100**, which may be used to implement methods to monitor components of an aircraft landing system disclosed herein. In the illustrated example, the aircraft **100** includes a landing system **102** to support the aircraft **100** on a surface **104** (e.g., a runway) and enable the aircraft **100** to taxi, take off, land, etc. The example landing system **102** includes a front landing gear unit **106** and two rear landing gear units **108** and **110**. However, the above-noted numbers of front and rear landing units are merely examples and, thus, other examples may employ other numbers of front landing gear units and/or rear landing gear units without departing from the scope of this disclosure.

[0022] To travel from one destination (e.g., airport) to another, the example aircraft **100** may perform a plurality of braking events such as, for example, taxiing from a departure gate to a runway, landing, taxiing from a runway to an arrival gate, and parking. During a given time period (e.g., one day), the example aircraft **100** may travel or be scheduled to travel to a plurality of destinations and, thus, perform or be scheduled to perform a plurality of braking events.

[0023] FIG. 2 illustrates an example landing gear unit **200**, which may be used to implement the landing system **102** of the example aircraft **100** of FIG. 1. In the illustrated example, the landing gear unit **200** includes a strut **202**, an axle assembly **204**, two wheel assemblies **206** and **208**, and

two brake assemblies **210** and **212**. Each of the brake assemblies **210** and **212** is coupled to the axle assembly **204** and a respective one of the wheel assemblies **206** and **208**. The example landing gear unit **200** may include a plurality of actuators, sensors and/or other devices, which may be controlled by and/or communicate with one or more aircraft control systems of the example aircraft **100**.

[0024] The wheel assemblies **206** and **208** of the example landing gear unit **200** are substantially similar, and the brake assemblies **210** and **212** of the example landing gear unit **200** are substantially similar. Thus, the following description of the brake assembly **210** and the wheel assembly **206** disposed on a right side of the strut **202** in the orientation of FIG. 2 is applicable to the brake assembly **212** and the wheel assembly **208** disposed on a left side of the strut **202** in the orientation of FIG. 2. Therefore, to avoid redundancy, the wheel assembly **208** and the brake assembly **212** on the left side of the strut **202** in the orientation of FIG. 2 are not separately described.

[0025] In the illustrated example, wheel assembly **206** includes a wheel **214** and a tire **216**. The example brake assembly **210** includes a housing **218**, brakes (e.g., one or more rotors and stators), pistons and/or other components. In the illustrated example, the brakes are received in a tubewell **220** of the wheel **214**. When the brake assembly **210** is operated, the brakes convert kinetic energy of the wheel **214** into brake energy (e.g., heat energy). As a result, a temperature of the brake assembly **210** increases. In the illustrated example, a brake temperature sensor **222** (e.g., a thermocouple) is coupled to the landing gear unit **200** to acquire information related to the temperature of the brake assembly **210** (“brake temperature information”). The example brake temperature sensor **222** of FIG. 2 is disposed on the housing **218** of the brake assembly **210**. In other examples, the brake temperature sensor **222** may be coupled to other components

of the brake assembly **210**, the axle assembly **204**, the strut **202**, the wheel **214**, and/or any other suitable component of the landing gear unit **200**. As described in greater detail below, the temperature of the brake assembly **210** may be used to estimate an increase in temperature of the wheel **214** as a result of a braking event.

[0026] FIG. 3 is a view of a first side of the example wheel assembly **206** of FIG. 2. In the illustrated example, the wheel **214** includes an example fuse plug **300**. The example fuse plug **300** is coupled to the wheel **214** via the tubewell **220**. Although one fuse plug is shown in the illustrated example, the wheel **214** may include a plurality of fuse plugs, which may be spaced apart along the wheel **214** (e.g., three fuse plugs radially spaced apart by about **120** degrees).

[0027] The example fuse plug **300** of FIG. 3 is in communication with the interior space of the tire **216** between the wheel **214** and the tire **216**. When a temperature of the fuse plug **300** is below a threshold temperature, the fuse plug **300** enables the tire **216** to be inflated and/or pressurized. If the temperature of the fuse plug **300** reaches or exceeds the threshold temperature, a portion (e.g., a eutectic core) of the fuse plug **300** melts to release air from in the tire **216**.

[0028] The example wheel assembly **206** includes a heat shield **302** coupled to the wheel **214**. The example heat shield **302** is disposed between the brake assembly **210** and the wheel **214** to prevent and/or mitigate convective and/or radiative heat transfer from the brake assembly **210** to the wheel **214** and the fuse plug **300**.

[0029] FIG. 4 is a view of a second side of the example wheel assembly **206** of FIGS. 2-3. In the illustrated example, the wheel assembly **206** includes a cap **400** coupled to the wheel **214**. The wheel assembly **206** also includes a tire inflation valve **402**. Air may be flowed into the tire **216** via the tire inflation valve **402** to inflate the tire **216** and/or pressurize the tire **216**.

[0030] FIG. 5 is a cross-sectional view of the example wheel 214 and the example tire inflation valve 402 of FIG. 4. In the illustrated example, a wheel temperature sensor 500 (e.g., a thermocouple) is disposed in the tire inflation valve 402. In other examples, the wheel temperature sensor 500 is disposed in and/or on other portions of the wheel assembly 206 (e.g., the cap 400, the tubewell 220 of the wheel 214, a rim of the wheel 214, etc.). The wheel temperature sensor 500 acquires information related to a temperature of the wheel 214 (“wheel temperature information”). As described in greater detail below, the temperature of the wheel 214 and the temperature of the brake assembly 210 may be used to estimate a maximum temperature of the wheel 214 as a result of a braking event.

[0031] FIG. 6 is a block diagram of an example fuse plug monitoring system 600 disclosed herein. The example fuse plug monitoring system 600 includes a temperature monitoring unit 602 in communication with the brake temperature sensor 222 and the wheel temperature sensor 500. The example temperature monitoring unit 602 monitors temperatures of the wheel 214 (“wheel temperatures”) and temperatures of the brake assembly 210 (“brake assembly temperatures”). As described in greater detail below in conjunction with FIG. 7, in some examples, the temperature monitoring unit 602 determines estimated maximum temperatures of the wheel 214 resulting from one or more braking events performed by the example aircraft 100 based on the wheel temperatures and/or the brake assembly temperatures.

[0032] The temperature monitoring unit 602 may be implemented by and/or in communication with an aircraft control system 604 disposed on the aircraft 100 or a monitoring device 606 disposed outside of the aircraft 100 (e.g., a portable or handheld device (e.g., a laptop, a smartphone, a portable diagnostic tool, etc.), a workstation (e.g., located in a maintenance facility, a ground control facility, etc.), and/or any other suitable device and/or system. The

example temperature monitoring unit **602** may operate while the aircraft **100** is on the surface **104** of Earth and/or in flight.

[0033] During operation of the example aircraft **100**, the wheel temperature sensor **500** communicates the wheel temperature information to the temperature monitoring unit **602**. Based on the wheel temperature information, the temperature monitoring unit **602** determines one or more wheel temperatures.

[0034] During a braking event, kinetic energy is converted into brake energy via the brake assembly **210**. As a result, heat Q is generated by the brake assembly **210**. The heat Q may be transferred from the brake assembly **210** to the axle assembly **204**, the heat shield **302**, the wheel **214**, the fuse plug **300**, and/or other components of the landing gear unit **200**. As a result, a temperature of the wheel **214** and/or a temperature of the fuse plug **300** may increase during the braking event. After the braking event has concluded (e.g., upon takeoff, once the aircraft **100** is parked, etc.), the wheel **214** and the fuse plug **300** may continue to absorb heat energy generated by the brake assembly **210**. As a result, the temperatures of the wheel **214** and the fuse plug **300** may increase until a given amount of time after the braking event has concluded.

[0035] The example brake temperature sensor **222** communicates brake assembly temperature information to the temperature monitoring unit **602**. In some examples, based on the brake temperature information, the temperature monitoring unit **602** determines a temperature of the brake assembly **210**. Based on the temperature of the brake assembly **210** and the temperature of the wheel **214**, the temperature monitoring unit **602** determines an estimated temperature increase of the wheel **214** over a predetermined amount of time (e.g., fifteen minutes). Based on the temperature of the wheel **214** and the estimated wheel temperature increase, the temperature

monitoring unit **602** estimates a maximum temperature of the wheel **214** during the predetermined amount of time.

[0036] Based on the maximum wheel temperature, the temperature monitoring unit **602** may generate and/or communicate an alert. In some examples, the alert may indicate that the temperature of the fuse plug **300** has or will exceed the fuse plug melting temperature and, thus, is at risk of melting. In some examples, the alert is generated by illuminating a light via a cockpit display **608**. In some examples, the message is displayed via the cockpit display **608**, a display **610** of the monitoring device **606**, and/or any other suitable display.

[0037] In some examples, the temperature monitoring unit **602** communicates the message if the estimated maximum wheel temperature is greater than a predetermined threshold temperature such as, for example, **340** degrees Fahrenheit. In some examples, the predetermined threshold temperature takes into account factors and/or conditions related to the wheel assembly **206** and/or, more specifically, the fuse plug **300** to enable the wheel temperature to be used by the example temperature monitoring unit **602** to detect if one or more past or future braking events risk melting the fuse plug **300**. In some examples, the predetermined threshold temperature is based on an estimated melting temperature of the fuse plug **300**, a position of the fuse plug **300** relative to the wheel temperature sensor **500**, and/or other conditions and/or factors. In some examples, the predetermined threshold temperature is expressed as follows:

$$\text{Equation 1: } T_{\text{threshold}} = T_{\text{melting}} - T_{\text{melting temperature factor}} - T_{\text{position factor}} - T_{\text{wheel temperature factor}}$$

[0038] In Equation 1, T_{melting} is a temperature at which the example fuse plug **300** is to melt. $T_{\text{melting temperature factor}}$ is a fuse plug melting temperature tolerance factor equal to, for example, a number of degrees less than the estimated melting temperature at which the fuse plug **300** may melt. For example, if the fuse plug **300** is to melt at **390** degrees Fahrenheit but experimental

data and/or testing indicates that the fuse plug **300** may melt at temperatures as low as **370** degrees, the fuse plug melting temperature tolerance factor may be twenty degrees (**390** – **370** = **20**). $T_{position\ factor}$ is a fuse plug position factor that is equal to an estimated maximum difference in temperature between the wheel temperature measured via the wheel temperature sensor **500** and a temperature of fuse plug **300** as a result of a radial position of the fuse plug **300** relative to the wheel temperature sensor **500**. For example, because heat Q generally rises, if the fuse plug **300** is disposed above the wheel temperature sensor **500** relative to the surface **104** of Earth, the temperature of the fuse plug **300** may be greater than a temperature of the wheel **214** determined via the wheel temperature sensor **500**. If the fuse plug **300** is disposed below the wheel temperature sensor **500** relative to the surface **104** of Earth, the temperature of the fuse plug **300** may be less than the temperature of the wheel **214** determined via the wheel temperature sensor **500**. In some examples, the fuse plug position factor is determined based on the estimated difference in temperature between the wheel temperature measured via the wheel temperature sensor **500** and the fuse plug temperature when the fuse plug **300** is at a highest point on the wheel **214** relative to the surface **104** of Earth.

[0039] $T_{wheel\ temperature\ factor}$ is a wheel temperature tolerance factor equal to an estimated difference between the wheel temperature measured by the wheel temperature sensor **500** and a temperature of the fuse plug **300** as a result of variations in temperature of the wheel **214** and/or relative proximities of the fuse plug **300** and the wheel temperature sensor **500** to the brake assembly **210**. For example, because the example fuse plug **300** is disposed closer to the example brake assembly **210** than the wheel temperature sensor **500**, the fuse plug temperature may be higher than the wheel temperature measured via the wheel temperature sensor **500**. In some examples, because the predetermined threshold temperature takes into account some or all

of the foregoing factors and/or conditions, the temperature monitoring unit **602** may determine if the fuse plug **300** is at risk of melting independent of a state of wear of the brake assembly **210**.

[0040] FIG. 7 illustrates an example data structure **700**, which may be used by the temperature monitoring unit **602** to determine the estimated maximum wheel temperature. The example data structure **700** of FIG. 7 is a table. In other examples, other data structures may be used. In the illustrated example, the temperature monitoring unit **602** employs the example table **700** if the brake assembly temperature is increasing and/or greater than a predetermined brake assembly temperature such as, for example, **500** degrees Fahrenheit. If the brake assembly temperature is increasing and/or greater than the predetermined brake assembly temperature, the temperature monitoring unit **602** retrieves an estimated increase in the wheel temperature (e.g., ΔT_{12}) from the table **700** based on the wheel temperature and the brake assembly temperature. Based on the estimated increase in the wheel temperature and the wheel temperature, the temperature monitoring unit **602** determines the estimated maximum wheel temperature. For example, the temperature monitoring unit **602** adds the estimated increase in the wheel temperature to the wheel temperature to determine the estimated maximum wheel temperature.

[0041] The example table **700** of FIG. 7 is organized based on estimated heating patterns of the wheel **214**. In the illustrated example, the estimated heating patterns are based on experimentally determined heating patterns of one or more wheels similar or identical to the example wheel **214**. In the illustrated example, the table **700** is organized using three predetermined wheel temperature ranges. In the illustrated example, a first predetermined wheel temperature range is less than a first temperature T_1 . An example second predetermined wheel temperature range of the example table **700** is between the first temperature T_1 and a second temperature T_2 . An example third predetermined wheel temperature range of the example table **700** is greater than

the second temperature T_2 . In other examples, the data structure **700** is organized using other numbers of predetermined wheel temperature ranges and/or in other ways.

[0042] The estimated heating patterns are used to determine if the fuse plug **300** is at risk of melting. For example, if the wheel temperature is within the first predetermined wheel temperature range (e.g., less than the first temperature T_1), the wheel **214** may increase in temperature according to a first function or heating curve during a braking event. If the wheel temperature is within the second predetermined wheel temperature range (e.g., between the first temperature T_1 and the second temperature T_2), the wheel **214** may increase in temperature according to a second function or heating curve during a braking event. For example, the wheel **214** may increase in temperature at a greater rate if the wheel temperature is within the first predetermined temperature range than if the wheel temperature is within the second predetermined temperature range. In some examples, if the wheel **214** has a wheel temperature within the third predetermined temperature range, the wheel **214** increases in temperature according to a third function or heating curve during a braking event.

[0043] In some examples, the heating patterns of the wheel **214** are influenced by the brake assembly temperature. Thus, an increase in temperature of the wheel may be a function of the brake assembly temperature as well as the wheel temperature. In the illustrated example, the example table **700** includes estimated increases in the wheel temperature (e.g., ΔT_{12}) that are each paired or associated with one of the predetermined wheel temperature ranges and one of the predetermined brake assembly temperature ranges. In some examples, the estimated wheel temperature increases are determined experimentally by, for example, acquiring data by monitoring temperatures of wheels and/or brake assemblies of one or more aircrafts substantially similar to the example aircraft **100** during a plurality of braking events.

[0044] In the illustrated example, the brake assembly temperature ranges are in Brake Temperature Management System (BTMS) scaling, which is unitless. The example brake assembly temperature ranges of the example table 700 of FIG. 7 are less than BTMS 4, BTMS 4-4.9, BTMS 5-5.9, BTMS 6-6.9, and BTMS 7-9.9. In other examples, the brake assembly temperature ranges employ other types of scaling and/or are other ranges. In some examples, the brake assembly temperature ranges are not scaled.

[0045] The example temperature monitoring unit 602 determines which estimated increase in the wheel temperature to retrieve from the table 700 by determining which one of the wheel temperature ranges and which one of the brake temperature ranges include the wheel temperature determined via the wheel temperature sensor 500 and the brake assembly temperature determined via the brake temperature sensor 222, respectively. For example, when the temperature monitoring unit 602 determines the wheel temperature and the brake assembly temperature, the temperature monitoring unit 602 determines if the wheel temperature is within the first predetermined wheel temperature range, the second predetermined wheel temperature range or the third predetermined wheel temperature range. If, for example, the wheel temperature is within the second predetermined wheel temperature range, the temperature monitoring unit 602 determines which one of the brake assembly temperature ranges associated with the second predetermined wheel temperature range includes the brake assembly temperature. For example, if the brake assembly temperature is BTMS 5.5, the temperature monitoring unit 602 determines that BTMS 5-5.9 includes BTMS 5.5. In the illustrated example, the temperature monitoring unit 602 then retrieves the estimated wheel temperature increase associated or paired with BTMS 5-5.9. In the illustrated example, the estimated wheel

temperature increase associated with BTMS 5-5.9 is represented in the example table 700 of FIG. 7 as ΔT_6 .

[0046] In some examples, the temperature monitoring unit 602 adds the estimated wheel temperature increase to the wheel temperature to determine an estimated maximum wheel temperature. In some examples, the estimated maximum wheel temperature is an estimated maximum wheel temperature at a future time such as, for example, fifteen minutes after the wheel temperature is determined. If the maximum wheel temperature is greater than the predetermined threshold temperature, the temperature monitoring system 602 communicates a message or alert indicating that the fuse plug 300 may melt.

[0047] During some braking events, the brake assembly temperature does not substantially increase, but sufficient heat is transferred to the wheel 214 to melt the fuse plug 300. For example, an extended period of light braking during taxiing may not increase the brake assembly temperature above 500 degrees, but sufficient heat may transfer to the wheel 214 to melt the fuse plug 300. Thus, in some examples, the temperature monitoring unit 602 does not use the example table 700 if the brake assembly temperature is below the predetermined brake assembly temperature. Instead, the example temperature monitoring unit 602 compares only the wheel temperature to the predetermined threshold temperature to determine if an alert indicating the fuse plug 300 may melt is to be communicated. Thus, the example temperature monitoring unit 602 may detect if the fuse plug 300 is at risk of melting when the brake assembly 210 is cold (e.g., below the predetermined brake assembly temperature).

[0048] In some examples, if the temperature monitoring unit 602 determines that the wheel temperature peaks, the temperature monitoring unit 602 ceases to use the example table 700 to determine if an alert is to be communicated until a subsequent braking event is detected. A peak

wheel temperature is a maximum wheel temperature resulting from a braking event. In some examples, once the wheel temperature peaks, the example temperature monitoring unit **602** compares only the wheel temperature to the predetermined threshold temperature to determine if the alert is to be communicated. If a braking event is subsequently detected, the example temperature monitoring unit **602** reverts back to employing the example table **700**. Thus, the example temperature monitoring unit **602** may detect if the fuse plug **300** is at risk of melting after a braking event is completed. In some examples, the temperature monitoring unit **602** detects a braking event by determining that the wheel temperature and/or the brake assembly temperature is increasing.

[0049] In some examples, the temperature monitoring unit **602** determines if a temperature of the wheel **214** is a peak temperature of the wheel **214** by determining if the wheel temperature is increasing, decreasing or substantially constant at a first time. If the wheel temperature is increasing at the first time, the temperature monitoring unit **602** determines that the wheel temperature is below the peak wheel temperature. If the wheel temperature is decreasing at the first time, the temperature monitoring unit **602** determines that the wheel temperature is below the peak temperature. If the wheel temperature is substantially constant at the first time, the temperature monitoring unit **602** determines that that wheel temperature is the peak temperature.

[0050] In some examples, the alert is communicated until one or more conditions are met. Once the one or more conditions are met, the alert is removed. For example, the alert may be communicated until the temperature monitoring unit **602** determines that the wheel temperature is decreasing, the wheel temperature is below the predetermined threshold temperature by a predetermined amount, and the brake assembly temperature is below a predetermined brake

assembly temperature. In other examples, the alert is removed if one or more different and/or additional conditions are met.

[0051] FIG. 8 is graph 800 illustrating wheel temperatures and brake assembly temperatures over a time period in which a plurality of braking events occurred. In the illustrated example, a first line 802 represents wheel temperatures and a second line 804 represents estimated maximum wheel temperatures. The example graph 800 includes a third line 806 representative of brake assembly temperatures. An example fourth line 808 represents the predetermined threshold temperature, and an example fifth line 810 indicates if an alert is communicated to indicate that the fuse plug 300 is at risk of melting. As illustrated in the example graph 800 of FIG. 8, when the estimated maximum wheel temperature reaches or exceeds the predetermined threshold temperature, the alert is communicated. After the wheel temperature peaks and the wheel temperature and the brake temperature sufficiently decline (e.g., the wheel temperature is a less than the predetermined threshold temperature by a predetermined amount and the brake assembly temperature is less than the predetermined brake temperature), the alert is removed.

[0052] While an example manner of implementing the example fuse plug monitoring system 600 is illustrated in FIG. 6, one or more of the elements, processes and/or devices illustrated in FIG. 6 may be combined, divided, re-arranged, omitted, eliminated and/or implemented in any other way. Further, the example brake temperature sensor 222, the example wheel temperature sensor 500, the example temperature monitoring unit 602, the example aircraft control system 604, the example cockpit display 608, the example monitoring device 606, the example display 604 and/or, more generally, the fuse plug monitoring system 600 of FIG. 6 may be implemented by hardware, software, firmware and/or any combination of hardware, software and/or firmware. Thus, for example, any of the example brake temperature sensor 222, the example

wheel temperature sensor **500**, the example temperature monitoring unit **602**, the example aircraft control system **604**, the example cockpit display **608**, the example monitoring device **606**, the example display **604** and/or, more generally, the fuse plug monitoring system **600** could be implemented by one or more analog or digital circuit(s), logic circuits, programmable processor(s), application specific integrated circuit(s) (ASIC(s)), programmable logic device(s) (PLD(s)) and/or field programmable logic device(s) (FPLD(s)). When reading any of the apparatus or system claims of this patent to cover a purely software and/or firmware implementation, at least one of the example brake temperature sensor **222**, the example wheel temperature sensor **500**, the example temperature monitoring unit **602**, the example aircraft control system **604**, the example cockpit display **608**, the example monitoring device **606**, the example display **604** and/or, more generally, the fuse plug monitoring system **600** of FIG. **6** is/are hereby expressly defined to include a tangible computer readable storage device or storage disk such as a memory, a digital versatile disk (DVD), a compact disk (CD), a Blu-ray disk, etc. storing the software and/or firmware. Further still, the example fuse plug monitoring system **600** of FIG. **6** may include one or more elements, processes and/or devices in addition to, or instead of, those illustrated in FIG. **6**, and/or may include more than one of any or all of the illustrated elements, processes and devices.

[0053] Flowcharts representative of example methods that may be used to implement the example temperature monitoring unit **602** of FIG. **6** are shown in FIGS. **8-10**. The example methods may be implemented using machine readable instructions that comprise a program for execution by a processor such as the processor **1212** shown in the example processor platform **1200** discussed below in connection with FIG. **12**. The program may be embodied in software stored on a tangible computer readable storage medium such as a CD-ROM, a floppy disk, a hard

drive, a digital versatile disk (DVD), a Blu-ray disk, or a memory associated with the processor **1212**, but the entire program and/or parts thereof could alternatively be executed by a device other than the processor **1212** and/or embodied in firmware or dedicated hardware. Further, although the example methods are described with reference to the flowcharts illustrated in FIGS. **9-11**, many other methods of implementing the example temperature monitoring unit **602** may alternatively be used. For example, the order of execution of the blocks may be changed, and/or some of the blocks described may be changed, eliminated, or combined.

[0054] As mentioned above, the example methods of FIGS. **9-11** may be implemented using coded instructions (e.g., computer and/or machine readable instructions) stored on a tangible computer readable storage medium such as a hard disk drive, a flash memory, a read-only memory (ROM), a compact disk (CD), a digital versatile disk (DVD), a cache, a random-access memory (RAM) and/or any other storage device or storage disk in which information is stored for any duration (e.g., for extended time periods, permanently, for brief instances, for temporarily buffering, and/or for caching of the information). As used herein, the term tangible computer readable storage medium is expressly defined to include any type of computer readable storage device and/or storage disk and to exclude propagating signals and to exclude transmission media. As used herein, "tangible computer readable storage medium" and "tangible machine readable storage medium" are used interchangeably. Additionally or alternatively, the example methods of FIGS. **9-11** may be implemented using coded instructions (e.g., computer and/or machine readable instructions) stored on a non-transitory computer and/or machine readable medium such as a hard disk drive, a flash memory, a read-only memory, a compact disk, a digital versatile disk, a cache, a random-access memory and/or any other storage device or storage disk in which information is stored for any duration (e.g., for extended time periods,

permanently, for brief instances, for temporarily buffering, and/or for caching of the information). As used herein, the term non-transitory computer readable medium is expressly defined to include any type of computer readable storage device and/or storage disk and to exclude propagating signals and to exclude transmission media. As used herein, when the phrase "at least" is used as the transition term in a preamble of a claim, it is open-ended in the same manner as the term "comprising" is open ended.

[0055] FIGS. 9-11 illustrate flowcharts representative example methods **900**, **1000** that can be performed to monitor components of an aircraft landing system. The example methods **900**, **1000** may be implemented using the example temperature monitoring unit **602** of FIG. 6. The example methods **900**, **1000** may be initiated at predetermined intervals of time, substantially continuously, or in response to a detected event and/or a condition being met (e.g., touchdown from flight, conclusion of a braking event, operation of the brake assembly **210**, a manual input, etc.). The example methods **900**, **1000** may be performed while the aircraft **100** is supported on the surface **104** of Earth (e.g., parked, taxiing, etc.) and/or in flight.

[0056] The example method **900** of FIG. 9 begins by determining a wheel temperature (block **902**). For example, the temperature monitoring unit **602** may determine the wheel temperature via the wheel temperature sensor **500**. A brake assembly temperature is determined (block **904**). For example, the temperature monitoring unit **602** may determine the brake assembly temperature via the brake temperature sensor **222**.

[0057] The temperature monitoring unit **602** retrieves an estimated increase in the wheel temperature from a data structure based on the wheel temperature and the brake assembly temperature (block **906**). For example, the temperature monitoring unit **602** may employ the example table **700** of FIG. 7 to retrieve the estimated increase in the wheel temperature. In some

examples, the estimated wheel temperature increase is based on estimated heating patterns of the wheel **214** and/or the brake assembly **210**.

[0058] The example temperature monitoring unit **602** determines an estimated maximum wheel temperature based on the wheel temperature and the estimated increase in the wheel temperature (block **908**). In some examples, the temperature monitoring unit **602** adds the estimated wheel temperature increase to the wheel temperature to determine the estimated maximum wheel temperature. In some examples, the estimated maximum wheel temperature is a temperature at which the wheel **214** is estimated to reach at a future time such as, for example, approximately fifteen minutes after the wheel temperature is determined.

[0059] The temperature monitoring unit **602** determines if the estimated maximum wheel temperature is greater than a predetermined threshold temperature (block **910**). In some examples, the predetermined threshold temperature is determined using Equation **1** above. If the estimated maximum wheel temperature is greater than the predetermined threshold temperature, an alert is generated (block **912**). For example, a cockpit light may be illuminated. If the estimated maximum wheel temperature is not greater than the predetermined threshold temperature, the example method **900** returns to block **902**.

[0060] FIG. **10** illustrates another example method **1000** disclosed herein. The example method of FIG. **10** begins by the temperature monitoring unit **602** determining a wheel temperature (block **1002**). The temperature monitoring unit **602** determines if the wheel temperature is a peak wheel temperature (block **1004**). In some examples, the temperature monitoring unit **602** determines if the wheel temperature is a peak wheel temperature by monitoring wheel temperatures over time and determining if the wheel temperature is increasing, decreasing, or substantially constant when the wheel temperature is determined at block **1002**. If the wheel

temperature is substantially constant (e.g., a rate of change of the wheel temperature is substantially zero) when the wheel temperature is determined, the temperature monitoring unit determines that the wheel temperature is the peak wheel temperature. If the wheel temperature is the peak wheel temperature, the temperature monitoring unit **602** determines if the wheel temperature is greater than a first predetermined threshold temperature (block **1006**). In some examples, the first predetermined threshold temperature is determined using Equation **1** above. If the wheel temperature is greater than the first predetermined threshold temperature, an alert is generated (block **1008**). In some example, the alert is generated by illuminating a light. By comparing the wheel temperature to the predetermined threshold temperature, the example temperature monitoring unit **602** may communicate alerts indicating that the fuse plug **300** is at risk of melting when the brake assembly **210** is cold and/or after a braking event has completed.

[**0061**] If the example temperature monitoring unit **602** determines that the wheel temperature is not a peak temperature, the temperature monitoring unit **602** determines a brake assembly temperature (block **1010**). For example, the temperature monitoring unit **602** may determine the brake assembly temperature via the brake temperature sensor **222**. In some examples, the temperature monitoring unit **602** determines the wheel temperature and the brake assembly temperature substantially contemporaneously.

[**0062**] The temperature monitoring unit **602** determines if the brake assembly temperature is greater than the predetermined brake assembly temperature (block **1012**). In some examples, the predetermined brake assembly temperature is **500** degrees Fahrenheit. If the brake assembly temperature is not greater than the predetermined brake assembly temperature, the example method **1000** continues to block **1006** and the temperature monitoring unit compares only the wheel temperature to the first predetermined threshold temperature. In the illustrated example, if

the brake assembly temperature is greater than the predetermined brake assembly temperature, the temperature monitoring unit **602** retrieves an estimated increase in the wheel temperature from a data structure based on the wheel temperature and the brake assembly temperature (block **1014**). In some examples, the estimated increase in the wheel temperature is experimentally determined by, for example, monitoring wheel temperatures and/or brake assembly temperatures of one or more wheels similar or identical to the example wheel **214** during a plurality of braking events. In some examples, the temperature monitoring unit **602** employs the example table **700** of FIG. **7** and retrieves the estimated increase in wheel temperature by determining which one of a plurality of wheel temperature ranges and brake assembly temperature ranges include the wheel temperature and the brake assembly temperature, respectively.

[0063] The temperature monitoring unit **602** determines an estimated maximum wheel temperature (block **1016**). In some examples, the temperature monitoring unit **602** determines the estimated maximum wheel temperature by adding the estimated increase in wheel temperature retrieved from the table **700** to the wheel temperature determined via the wheel temperature sensor **500**. The example temperature monitoring unit **602** determines if the estimated maximum wheel temperature is greater than the first predetermined threshold temperature (block **1018**). If the estimated maximum wheel temperature is greater than the first predetermined threshold temperature, an alert is generated (block **1008**). If the estimated maximum wheel temperature is not greater than the first predetermined threshold temperature, the example method returns to block **1002**.

[0064] Once the alert is generated, the example method **1000** continues to block **1100** of FIG. **11**. In the illustrated example, the temperature monitoring unit **602** determines if the wheel temperature is decreasing (block **1100**). If the wheel temperature is decreasing, the temperature

monitoring unit **602** determines if the wheel temperature is less than a second predetermined threshold temperature (block **1102**). In some examples, the second predetermined threshold temperature is less than the first predetermined threshold temperature. If the wheel temperature is less than the second predetermined threshold temperature, the temperature monitoring unit **602** determines if the brake assembly temperature is less than the predetermined brake assembly temperature (block **1104**). If the brake assembly temperature is less than the predetermined brake assembly temperature, the alert is removed (block **1106**), and the example method **1000** returns to block **1002**. For example, the light may be unilluminated. If any of the conditions of block **1100**, block **1102** or block **1104** are not met, the example method returns to block **1008** and, thus, the alert remains generated.

[0065] FIG. **12** is a block diagram of an example processing platform **1200** capable of executing machine readable instructions to implement the temperature monitoring unit **602** of FIG. **6**. The processing platform **1200** can be, for example, a server, a computer, a mobile device (e.g., a laptop, a smart phone, etc.), an Internet appliance, the aircraft control system **604**, the monitoring device **606**, or any other type of computing device.

[0066] The system **1200** of the instant example includes a processor **1212**. For example, the processor **1212** can be implemented by one or more microprocessors or controllers from any desired family or manufacturer.

[0067] The processor **1212** includes a local memory **1213** (e.g., a cache) and is in communication with a main memory including a volatile memory **1214** and a non-volatile memory **1216** via a bus **1218**. The volatile memory **1214** may be implemented by Synchronous Dynamic Random Access Memory (SDRAM), Dynamic Random Access Memory (DRAM), RAMBUS Dynamic Random Access Memory (RDRAM) and/or any other type of random

access memory device. The non-volatile memory **1216** may be implemented by flash memory and/or any other desired type of memory device. Access to the main memory **1214**, **1216** is controlled by a memory controller.

[0068] The processing platform **1200** also includes an interface circuit **1220**. The interface circuit **1220** may be implemented by any type of interface standard, such as an Ethernet interface, a universal serial bus (USB), and/or a PCI express interface.

[0069] One or more input devices **1222** are connected to the interface circuit **1220**. The input device(s) **1222** permit a user to enter data and commands into the processor **1212**. The input device(s) can be implemented by, for example, a keyboard, a mouse, a touchscreen, a track-pad, a trackball, isopoint and/or a voice recognition system, a switch, a button, an aircraft cockpit console device, etc.

[0070] One or more output devices **1224** are also connected to the interface circuit **1220**. The output devices **1224** can be implemented, for example, by display devices (e.g., a liquid crystal display, a cathode ray tube display (CRT), a printer and/or speakers). The interface circuit **1220**, thus, typically includes a graphics driver card.

[0071] The interface circuit **1220** also includes a communication device (e.g., communication device **56**) such as a modem or network interface card to facilitate exchange of data with external computers via a network **1226** (e.g., an Ethernet connection, a digital subscriber line (DSL), a telephone line, coaxial cable, a cellular telephone system, a satellite communications system, etc.).

[0072] The processing platform **1200** also includes one or more mass storage devices **1228** for storing software and data. Examples of such mass storage devices **1228** include floppy disk

drives, hard drive disks, compact disk drives and digital versatile disk (DVD) drives. The mass storage device 1228 may implement the local storage device 62.

[0073] Coded instructions 1232 that, when executed, cause a machine to perform the example methods 900, 1000 of FIGS. 9-11 may be stored in the mass storage device 1228, in the volatile memory 1214, in the non-volatile memory 1216, and/or on a removable storage medium such as a CD or DVD.

[0074] From the foregoing, it will be appreciated that the above-disclosed methods and apparatus may be used to monitor temperatures of a brake assembly and temperatures a wheel of an aircraft to determine estimated maximum temperatures of the wheel while the aircraft is parked, taxiing, in flight, landing and/or in any other state or phase of operation. Thus, during substantially all aspects of operation of the aircraft, the examples disclosed herein may determine if a fuse plug disposed on the wheel is at risk of melting by, for example, determining if the estimated maximum temperature of the wheel is exceeding or will exceed a predetermined threshold temperature. For example, the examples disclosed herein may determine if the fuse plug is at risk of melting before, during and after braking events, if the brake assembly and/or the wheel is cold, hot, increasing in temperature, at a substantially constant temperature, decreasing in temperature, and/or any in any other state and/or during any other aspect of operation. The examples disclosed herein take into account factors and/or conditions related to the brake assembly and/or the wheel such as, for example, an estimated melting temperature of the fuse plug, a position of the fuse plug relative to a wheel sensor, and/or other factors and/or conditions. The examples disclosed herein may also accurately and efficiently (e.g., in real-time) determine maximum temperatures of the wheel when the brake assembly is worn, substantially unworn, and/or in any other state of wear. Further, the examples disclosed herein employ techniques

(e.g., retrieving estimated wheel temperature increases from a table, comparing the estimated maximum temperatures of the wheel to the predetermined threshold temperature, etc.) that do not employ complex calculations or algorithms.

[0075] If the fuse plug is at risk of melting, the examples disclosed herein generate an alert to alert or notify an operator of the aircraft, an aircraft control system and/or other systems and/or personnel. Thus, the examples disclosed herein enable the operator of an aircraft, the aircraft control system, etc. to accurately and efficiently determine when to schedule future braking events (e.g., landing at a destination) and/or perform one or more actions to cool the brake assembly and/or the wheel to prevent the fuse plug from melting. Thus, amounts of time scheduled between braking events may be substantially reduced or minimized relative to conventional systems that employ conventional BTMS systems.

[0076] Although certain example methods, apparatus and articles of manufacture have been described herein, the scope of coverage of this disclosure is not limited thereto. On the contrary, this disclosure covers all methods, apparatus and articles of manufacture fairly falling within the scope of the claims.

[0077] The Abstract at the end of this disclosure is provided to allow the reader to quickly ascertain the nature of the technical disclosure. It is submitted with the understanding that it will not be used to interpret or limit the scope or meaning of the claims.

EMBODIMENTS IN WHICH AN EXCLUSIVE PROPERTY OR PRIVILEGE IS CLAIMED ARE DEFINED AS FOLLOWS:

1. A method comprising:
 - determining a first temperature of a wheel of an aircraft;
 - 5 determining a second temperature of a brake assembly operatively coupled to the wheel;
 - associating the first temperature with one of a plurality of predetermined ranges of wheel temperatures;
 - 10 associating the second temperature with one of a plurality of predetermined ranges of brake assembly temperatures;
 - determining an estimated increase in the first temperature associated with the one of the ranges of wheel temperatures and the one of the ranges of brake assembly temperatures; and
 - 15 determining a maximum temperature of the wheel based on the first temperature and the estimated increase in the first temperature.
2. The method of claim 1, further comprising determining if the maximum temperature is greater than a predetermined threshold temperature.
3. The method of claim 2, further comprising generating an alert if the maximum temperature is greater than the predetermined threshold temperature.
- 20 4. The method of claim 2 or 3, wherein the predetermined threshold temperature is less than a temperature at which a fuse plug of the wheel is to melt.

5. The method of any one of claims 1 to 4, wherein determining the estimated increase in the first temperature comprises retrieving the estimated increase in the first temperature from a table.
6. The method of any one of claims 1 to 5, wherein the estimated increase in the first temperature is based on experimentally determined heating patterns of one or more aircraft wheels.
7. A method, comprising:
- determining a brake assembly temperature;
 - determining a wheel temperature;
 - retrieving an estimated increase in the wheel temperature from a data structure based on the wheel temperature and the brake assembly temperature; and
 - determining a maximum wheel temperature based on the wheel temperature and the estimated increase in the wheel temperature.
8. The method of claim 7, wherein retrieving the estimated increase in the wheel temperature comprises:
- determining which one of a plurality of wheel temperature ranges and which one of a plurality of brake assembly temperature ranges in the data structure include the wheel temperature and the brake assembly temperature, respectively; and
 - retrieving the estimated increase in the wheel temperature associated with the one of the wheel temperature ranges and the one of the brake assembly temperature ranges.

9. The method of claim 7 or 8, further comprising:
- determining if the maximum wheel temperature is greater than a first predetermined threshold temperature; and
- generating an alert if the maximum wheel temperature is greater the first predetermined threshold temperature.
- 5
10. The method of claim 9, further comprising:
- monitoring the wheel temperature;
- monitoring the brake assembly temperature; and
- removing the alert if the wheel temperature decreases below a second predetermined threshold temperature and the brake assembly temperature is below a third predetermined threshold temperature.
- 10
11. The method of claim 7 or 8, further comprising:
- monitoring the wheel temperature;
- determining if the wheel temperature peaks;
- if the wheel temperature peaks, comparing only the wheel temperature to a first predetermined threshold temperature; and
- 15
- communicating an alert if the wheel temperature is greater than the first predetermined threshold temperature.
12. The method of any one of claims 7 to 11, wherein determining the brake assembly temperature comprises determining the brake assembly temperature via a first temperature sensor disposed on a brake assembly operatively coupled to a wheel, and
- 20

wherein determining the wheel temperature comprises determining the wheel temperature via a second temperature sensor disposed on the wheel.

- 13.** A method of determining if a fuse plug disposed on a wheel is at risk of melting, comprising:

5 determining a brake assembly temperature of a brake assembly operatively coupled to the wheel;

 determining a wheel temperature of the wheel;

 determining an estimated maximum temperature of the wheel based on the brake assembly temperature, the wheel temperature, and estimated heating
10 patterns of the wheel; and

 determining if the estimated maximum temperature of the wheel is greater than a predetermined threshold temperature.

- 14.** The method of claim **13**, wherein determining the estimated maximum temperature of the wheel comprises retrieving an estimated increase in the wheel temperature from a
15 data structure, wherein the estimated increase in the wheel temperature is determined based on one of the estimated heating patterns.

- 15.** The method of claim **13**, wherein determining if the fuse plug is at risk of melting comprises:

20 comparing the brake assembly temperature to a predetermined brake assembly temperature; and

 comparing the wheel temperature to a predetermined threshold temperature if the brake assembly temperature is less than the predetermined brake assembly temperature.

- 16.** The method of claim **13**, wherein determining if the fuse plug is at risk of melting comprises:
- determining if the wheel temperature is a peak wheel temperature; and
- comparing the wheel temperature to a predetermined threshold temperature if
5 the wheel temperature is the peak wheel temperature; and
- determining that the fuse plug is at risk of melting if the wheel temperature is greater than the predetermined threshold temperature.
- 17.** The method of claim **13**, further comprising generating an alert if the fuse plug is at risk of melting.
- 10 **18.** The method of claim **17**, further comprising removing the alert if the wheel temperature is decreasing, the wheel temperature is below a first predetermined temperature, and the brake assembly temperature is below a second predetermined temperature.
- 15 **19.** The method of any one of claims **13** to **18**, wherein determining the brake assembly temperature comprises determining the brake assembly temperature via a first temperature sensor disposed on a brake assembly operatively coupled to the wheel, and wherein determining the wheel temperature comprises determining the wheel temperature via a second temperature sensor disposed on the wheel.
- 20.** A method comprising:
- 20 determining a temperature of a wheel of an aircraft;
- determining a temperature of a brake assembly operatively coupled to the wheel;

determining an estimated increase in wheel temperature based on the temperature of the wheel and the temperature of the brake assembly; and

determining a maximum temperature of the wheel based on the temperature of the wheel and the estimated increase in wheel temperature.

5 **21.** The method of claim **20**, further comprising:

associating the temperature of the wheel with one of a plurality of predetermined ranges of wheel temperatures;

associating the temperature of the brake assembly with one of a plurality of predetermined ranges of brake assembly temperatures;

10 wherein the estimated increase in wheel temperature is determined on the basis of the associated one of the ranges of wheel temperatures and the associated one of the ranges of brake assembly temperatures.

22. The method of claim **20** or **21**, wherein the estimated increase in wheel temperature is based on experimentally determined heating patterns of one or more aircraft wheels.

15 **23.** The method of claim **20** or **21**, wherein the estimated increase in wheel temperature is determined by retrieval from a data structure based on the temperature of the wheel and the temperature of the brake assembly.

24. The method of claim **23**, wherein the data structure is a table.

20 **25.** The method of claim **24**, wherein retrieval of the estimated increase in wheel temperature comprises:

determining which said one of a plurality of predetermined ranges of wheel temperatures and which said one of a plurality of predetermined ranges of

brake assembly temperature in the data structure include the temperature of the wheel and the temperature of the brake assembly, respectively; and

retrieving the estimated increase in wheel temperature associated with the said one of the plurality of predetermined ranges of wheel temperatures and the said one of the plurality of predetermined ranges of brake assembly temperatures .

- 5
26. The method of any one of claims 20 to 25, further comprising determining if the maximum temperature is greater than a predetermined threshold temperature ($T_{\text{threshold}}$).
- 10 27. The method of claim 26, further comprising generating a first alert if the maximum temperature is greater than the predetermined threshold temperature ($T_{\text{threshold}}$).
28. The method of claim 26 or 27, further comprising generating a second alert if the temperature of the wheel is greater than the predetermined threshold temperature ($T_{\text{threshold}}$).
- 15 29. The method of any one of claims 26 to 28, wherein the predetermined threshold temperature ($T_{\text{threshold}}$) is less than a temperature at which a fuse plug of the wheel is to melt.
30. The method of any one of claims 26 to 29, wherein the predetermined threshold temperature is defined as:

$$T_{\text{threshold}} = T_{\text{melting}} - T_{\text{melting temperature factor}} - T_{\text{position factor}} - T_{\text{wheel temperature factor}}$$

20 in which T_{melting} is a fuse plug melting temperature, $T_{\text{melting temperature factor}}$ is a fuse plug melting temperature tolerance factor, $T_{\text{position factor}}$ is a fuse plug position factor, and $T_{\text{wheel temperature factor}}$ is a wheel temperature tolerance factor.

- 31.** The method of claim **28**, further comprising:
- monitoring the temperature of the wheel;
 - determining if the temperature of the wheel peaks;
 - if the temperature of the wheel peaks, comparing only the temperature of the wheel to the predetermined threshold temperature; and
 - communicating the second alert if the temperature of the wheel is greater than the predetermined threshold temperature.
- 32.** The method of claim **31**, further comprising:
- monitoring the temperature of the brake assembly; and
 - removing the second alert if the temperature of the wheel decreases below a second predetermined threshold temperature and the temperature of the brake assembly is below a third predetermined threshold temperature.
- 33.** The method of any one of claims **20** to **32**, wherein determining the temperature of the brake assembly comprises determining the temperature of the brake assembly via a first temperature sensor disposed on the brake assembly, and wherein determining the temperature of the wheel comprises determining the temperature of the wheel via a second temperature sensor disposed on the wheel.
- 34.** At least one computer-readable medium comprising codes stored thereon that, when executed by at least one computer, cause the at least one computer to implement the method of any one of claims **1** to **33**.
- 35.** A fuse plug monitoring system comprising:
- a wheel temperature sensor disposed on a wheel;

a brake temperature sensor disposed on a brake assembly operationally coupled to the wheel; and

a temperature monitoring unit in communication with the brake temperature sensor and the wheel temperature sensor, the temperature monitoring unit
5 configured to:

determine an estimated increase in wheel temperature on the basis of a wheel temperature communicated by the wheel temperature sensor and a brake temperature communicated by the brake temperature sensor;

determine a maximum temperature of the wheel based on the wheel
10 temperature and the estimated increase in wheel temperature.

- 36.** The system of claim 35 wherein the temperature monitoring unit is further configured to generate and communicate an alert if the maximum temperature is greater than a predetermined threshold temperature ($T_{\text{threshold}}$).

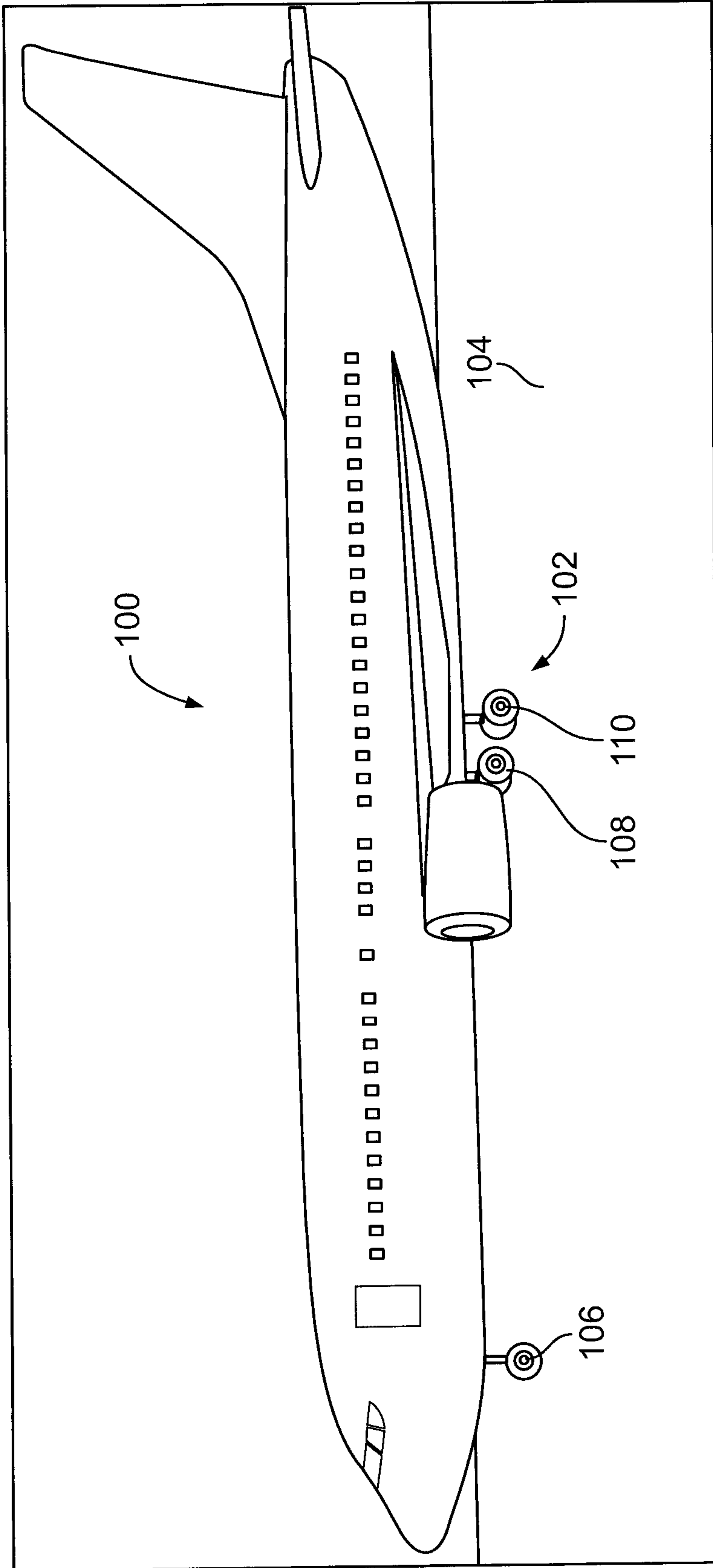

FIG. 1

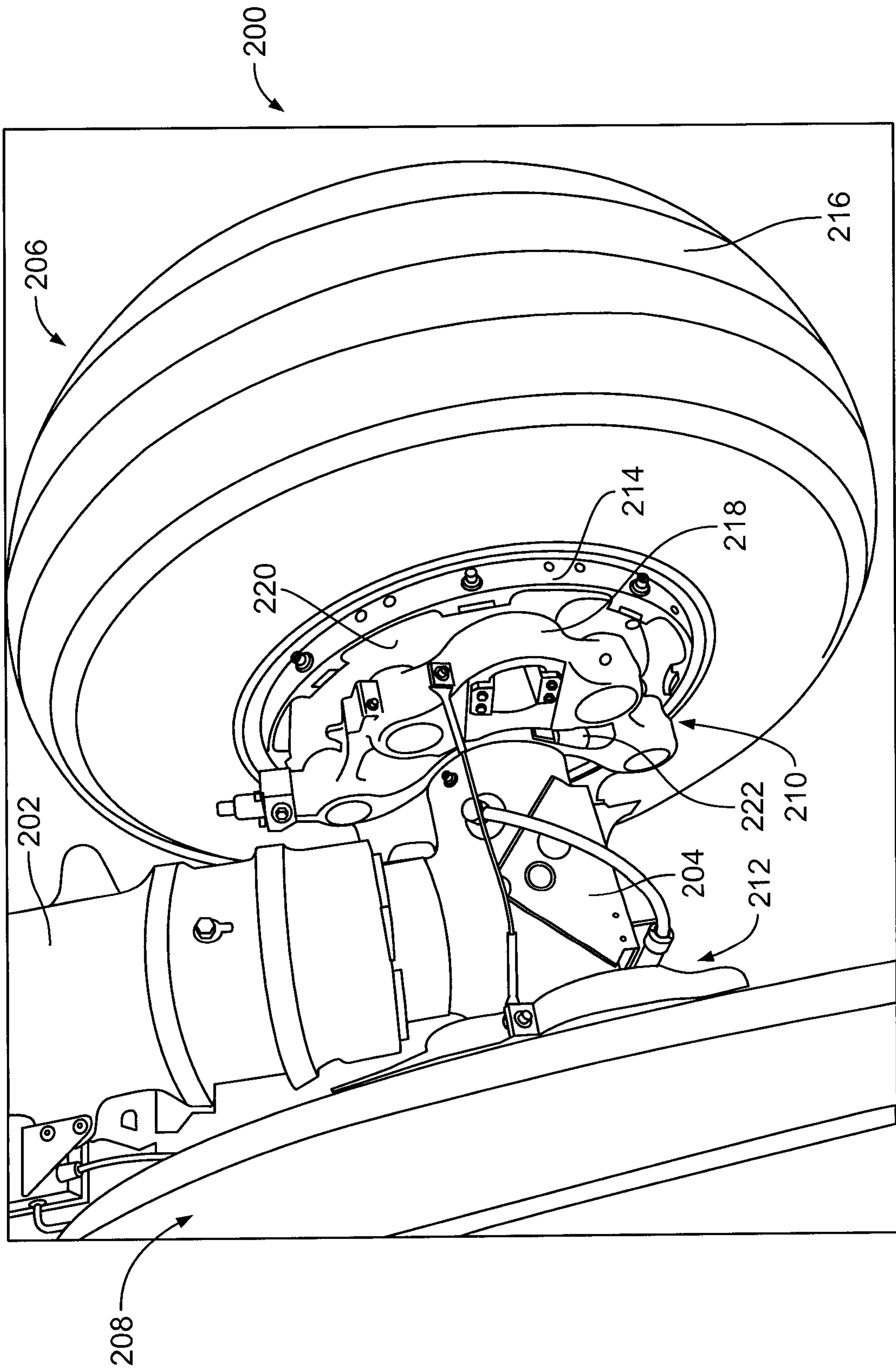

FIG. 2

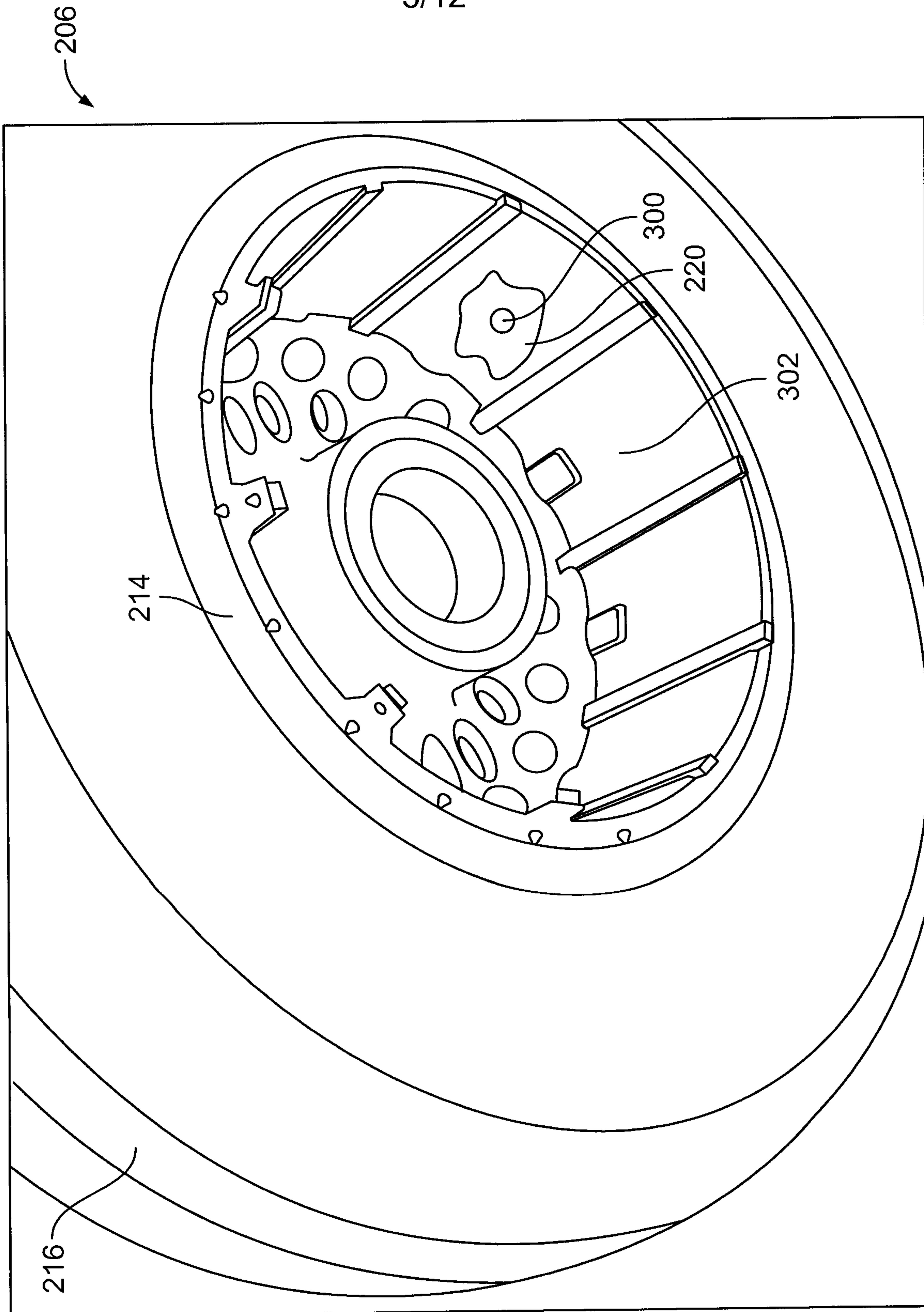

FIG. 3

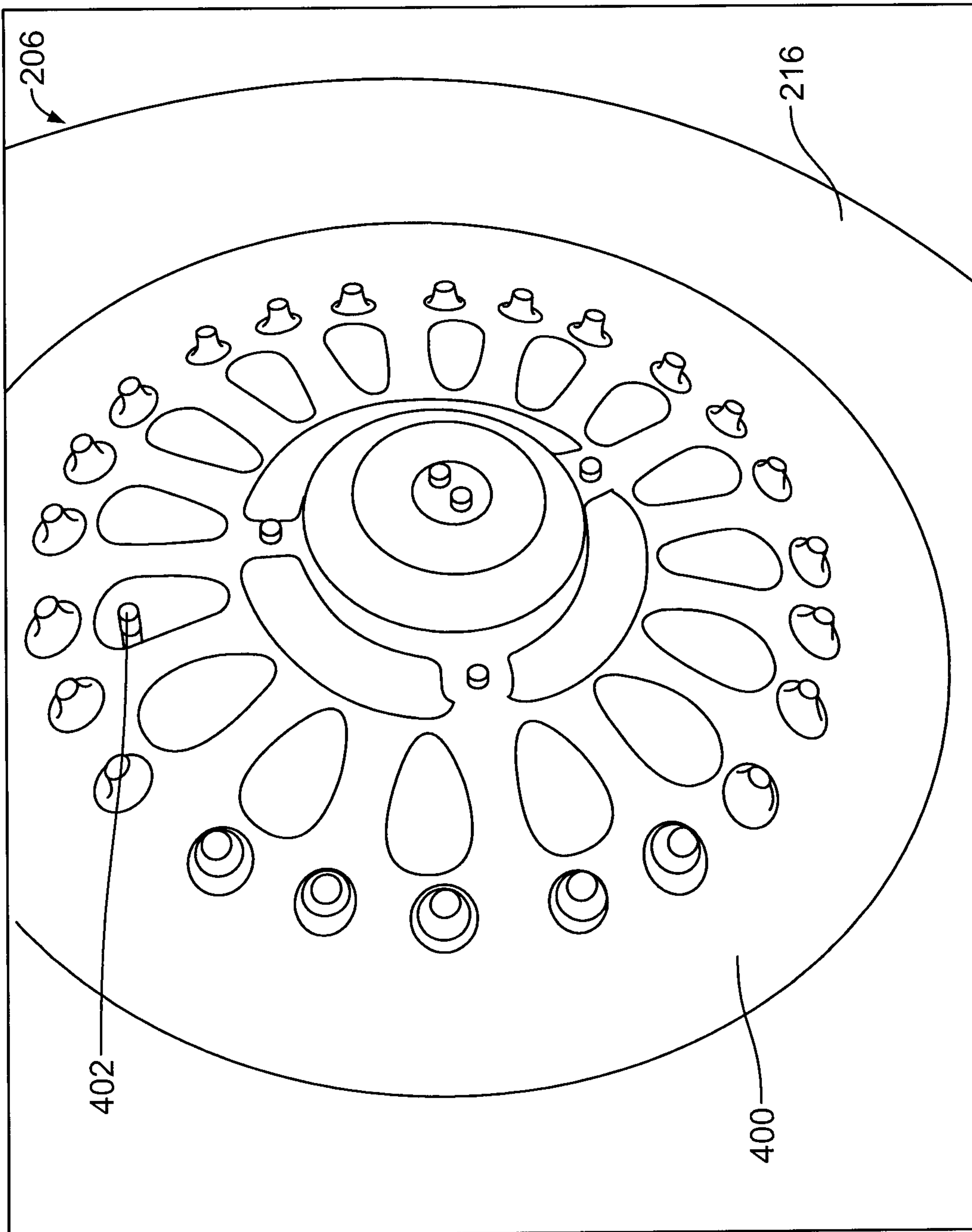

FIG. 4

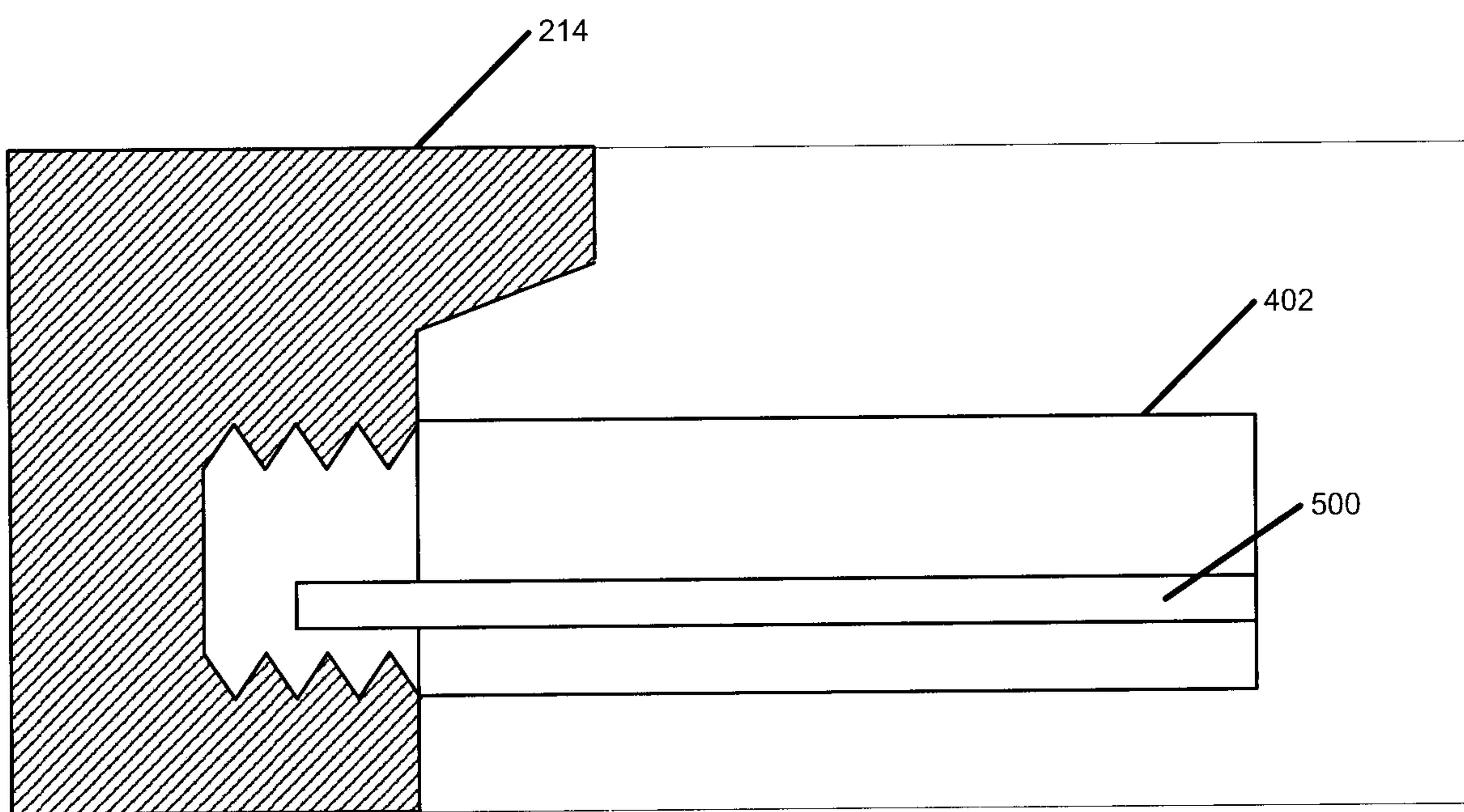

FIG. 5

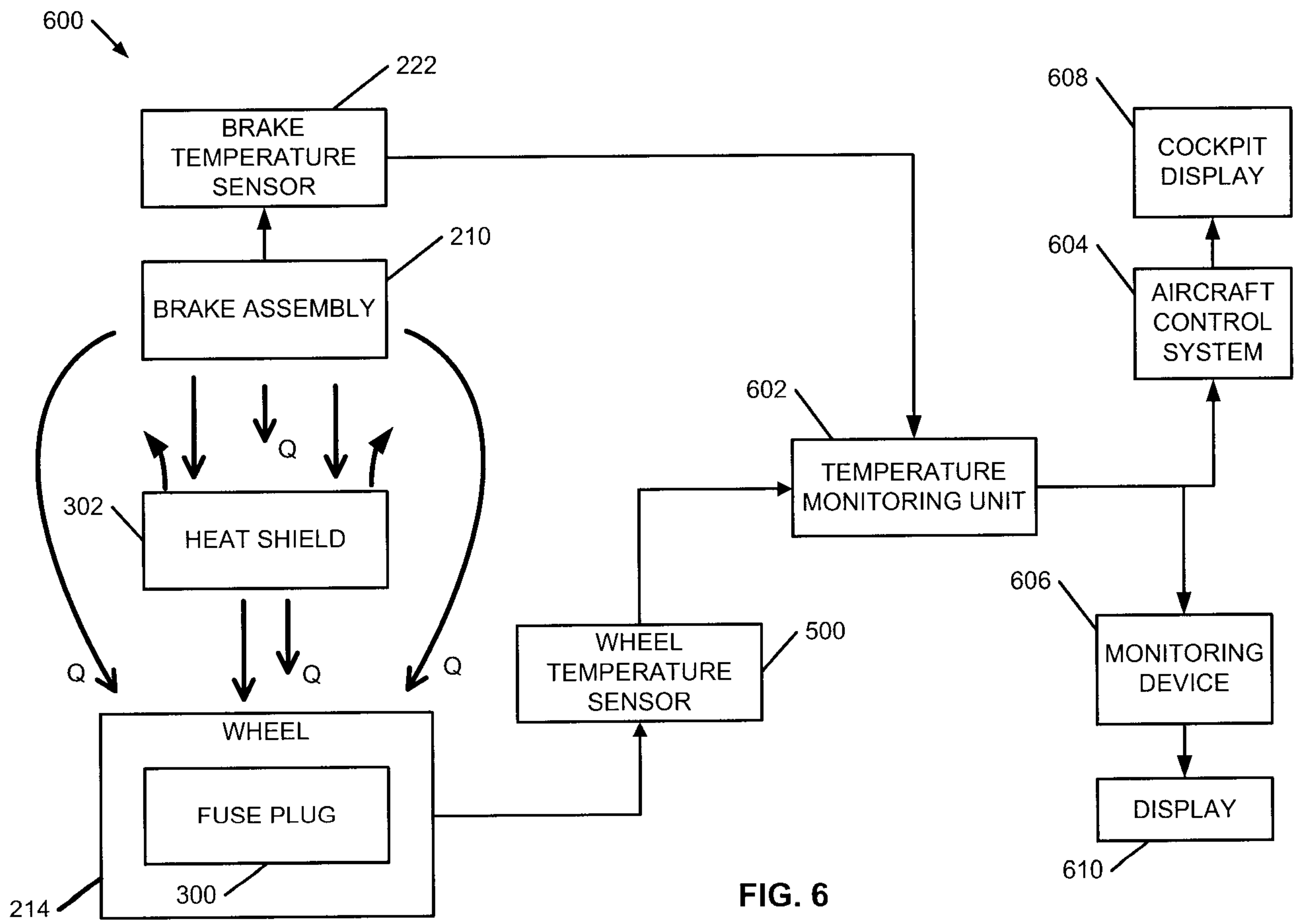

FIG. 6

700 ↘

FIRST WHEEL TEMPERATURE RANGE: WHEEL TEMPERATURE < T ₁		SECOND WHEEL TEMPERATURE RANGE: T ₁ < WHEEL TEMPERATURE < T ₂		THIRD WHEEL TEMPERATURE RANGE: WHEEL TEMPERATURE > T ₂	
BRAKE TEMPERATURE RANGE	ESTIMATED WHEEL TEMPERATURE INCREASE	BRAKE TEMPERATURE RANGE	ESTIMATED WHEEL TEMPERATURE INCREASE	BRAKE TEMPERATURE RANGE	ESTIMATED WHEEL TEMPERATURE INCREASE
< BTMS 4	0	< BTMS 4	0	< BTMS 4	0
BTMS 4 – BTMS 4.9	ΔT ₁	BTMS 4 – BTMS 4.9	ΔT ₅	BTMS 4 – BTMS 4.9	ΔT ₉
BTMS 5 – BTMS 5.9	ΔT ₂	BTMS 5 – BTMS 5.9	ΔT ₆	BTMS 5 – BTMS 5.9	ΔT ₁₀
BTMS 6 – BTMS 6.9	ΔT ₃	BTMS 6 – BTMS 6.9	ΔT ₇	BTMS 6 – BTMS 7.9	ΔT ₁₁
BTMS 7 – 9.9	ΔT ₄	BTMS 7 – 9.9	ΔT ₈	BTMS 7 – 9.9	ΔT ₁₂

FIG. 7

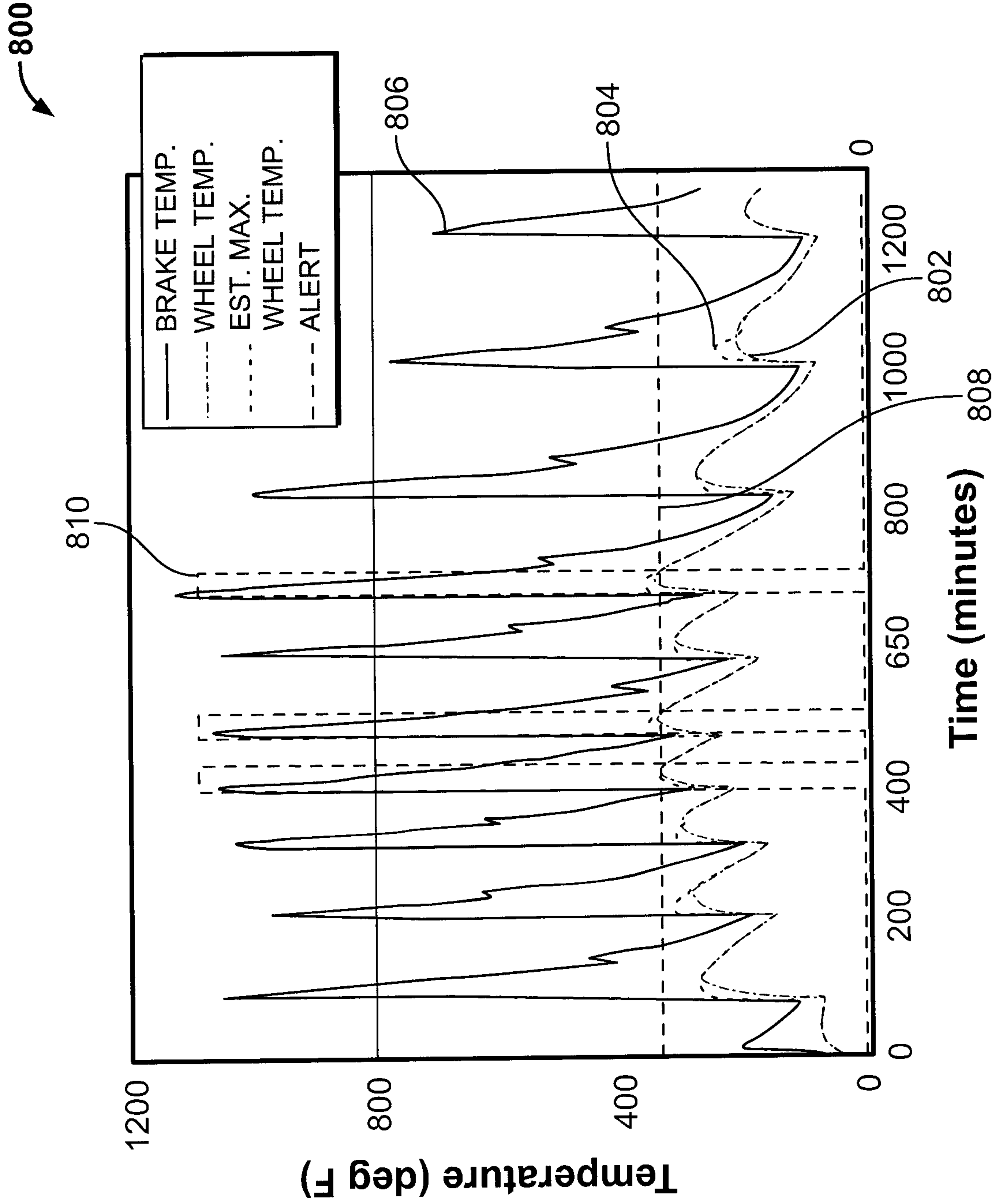

FIG. 8

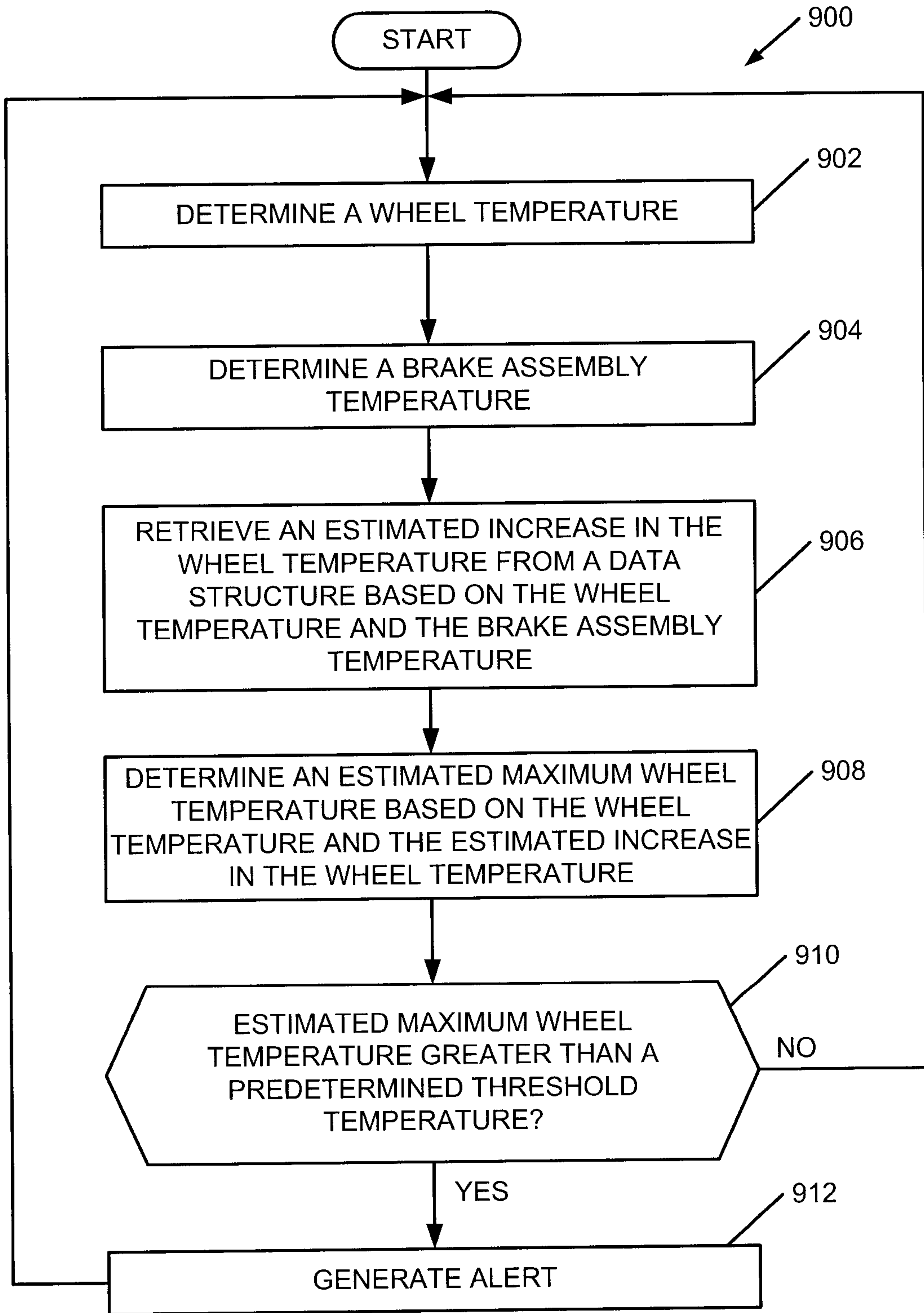

FIG. 9

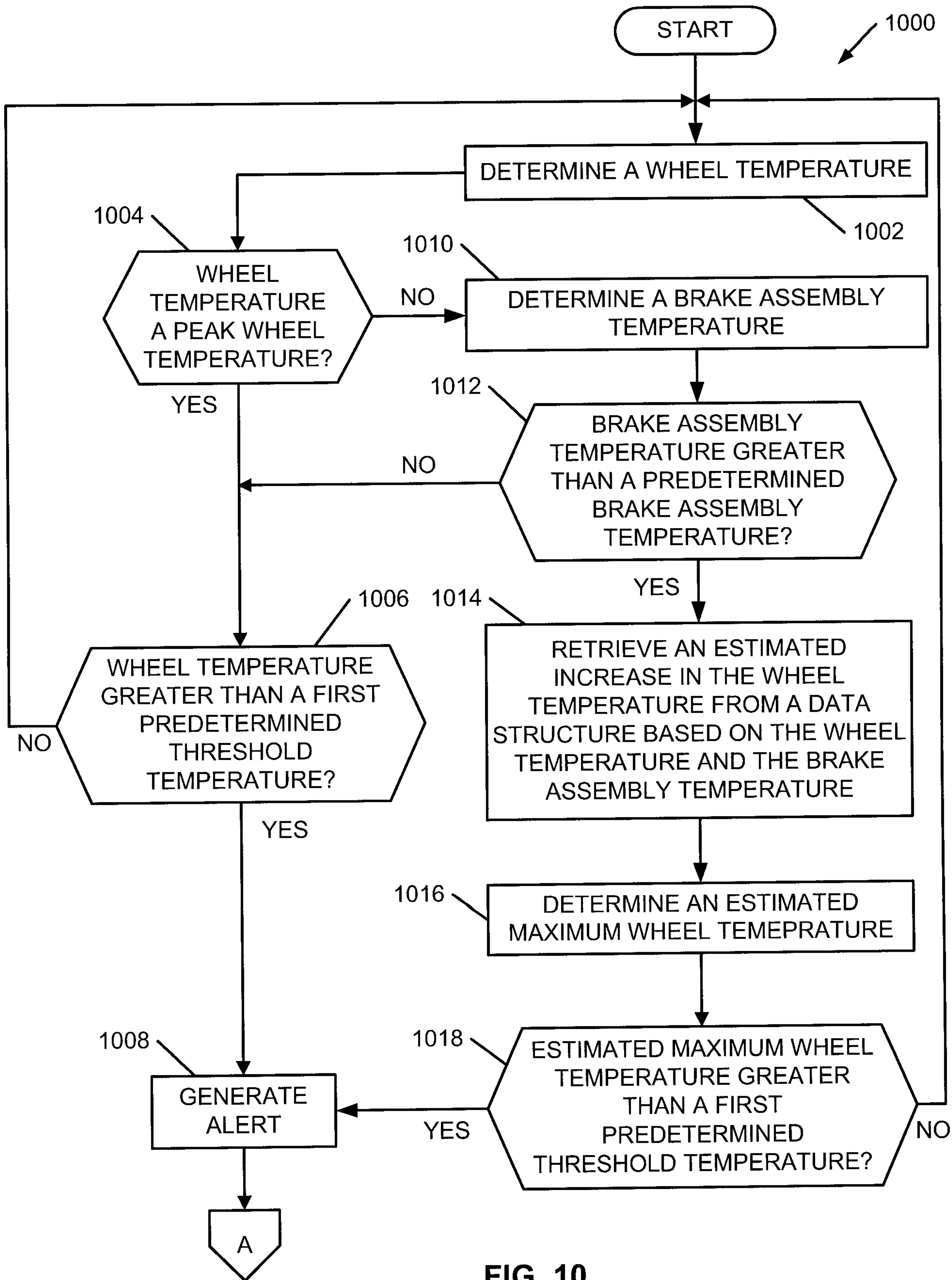

FIG. 10

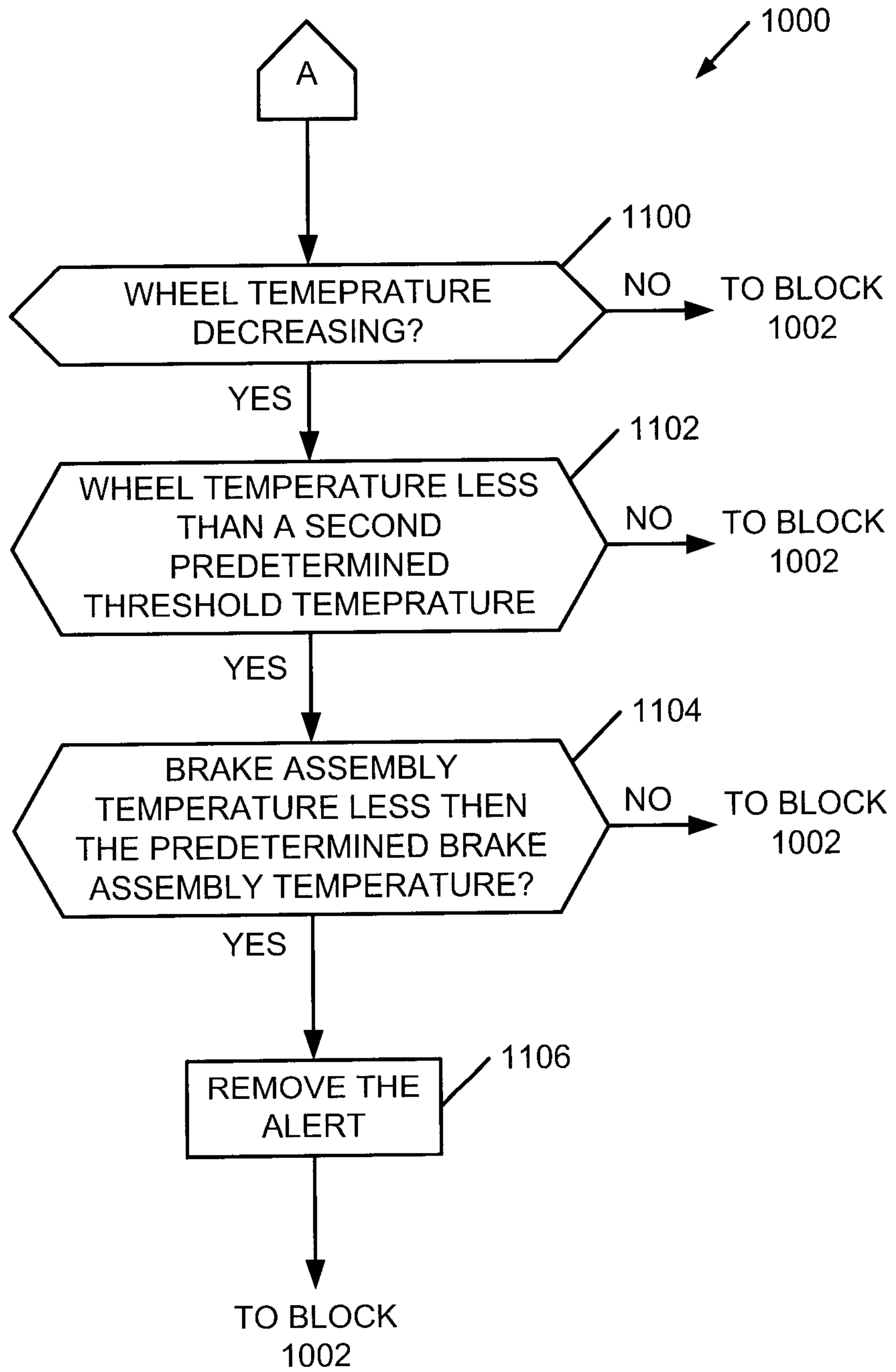

FIG. 11

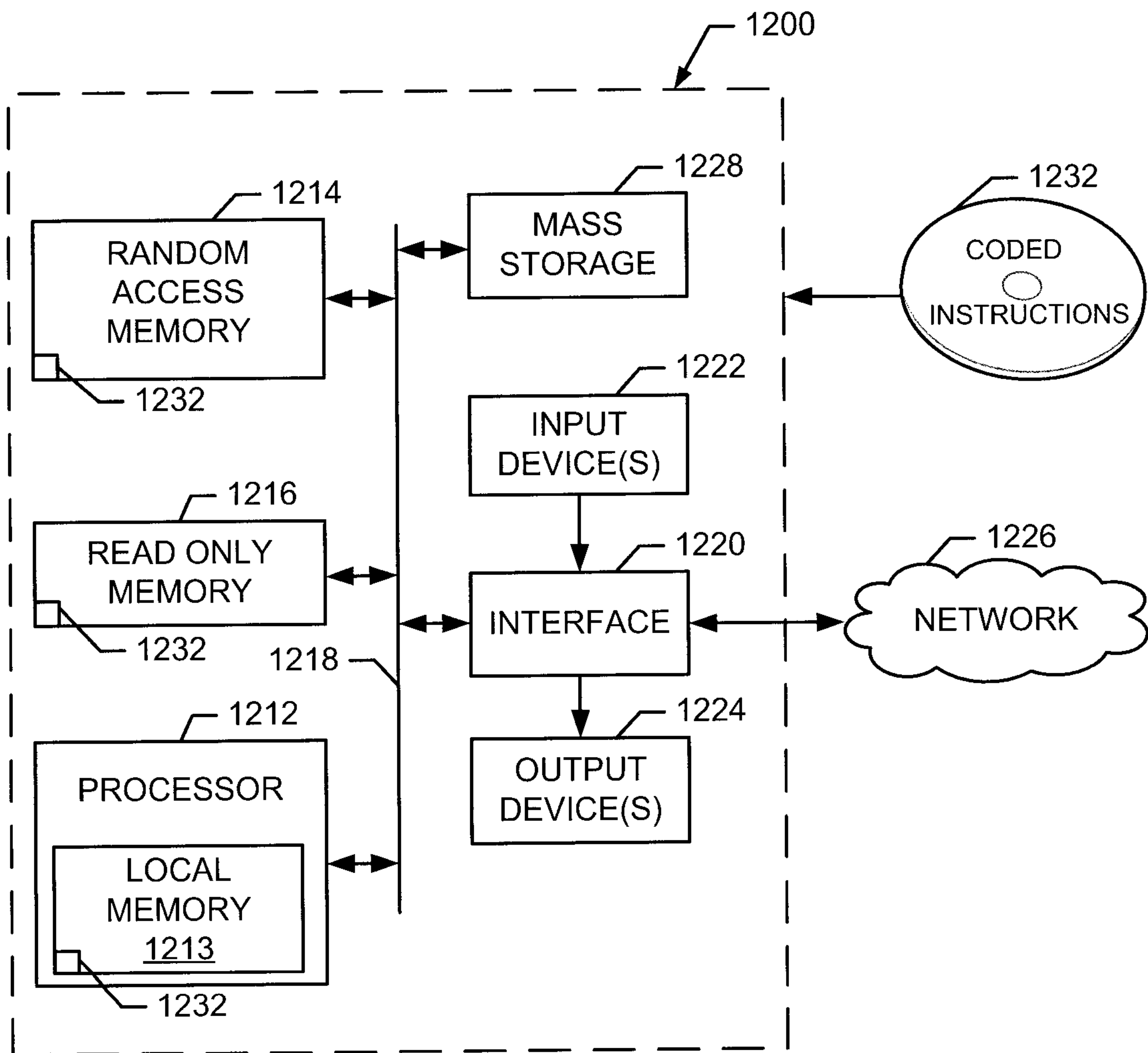

FIG. 12

