

10



Europäisches Patentamt  
European Patent Office  
Office européen des brevets

11 Publication number:

**0 068 111  
B1**

12

**EUROPEAN PATENT SPECIFICATION**

45 Date of publication of patent specification: **21.11.85**

51 Int. Cl.<sup>4</sup>: **H 01 J 19/22**

21 Application number: **82103884.1**

22 Date of filing: **05.05.82**

54 **Method of forming a cathode structure.**

30 Priority: **30.06.81 US 279281**

43 Date of publication of application:  
**05.01.83 Bulletin 83/01**

45 Publication of the grant of the patent:  
**21.11.85 Bulletin 85/47**

84 Designated Contracting States:  
**BE CH DE FR GB IT LI NL SE**

58 References cited:  
**EP-A-0 039 877  
DE-B-2 156 360  
DE-B-2 536 363  
US-A-3 978 364  
US-A-4 069 436  
US-A-4 121 130  
US-A-4 138 622**

73 Proprietor: **International Business Machines Corporation  
Old Orchard Road  
Armonk, N.Y. 10504 (US)**

72 Inventor: **Piggin, Bruce Paul  
Birch Lake North Common  
Sherfield English Hampshire (GB)**

74 Representative: **Ahlman, Bertel  
IBM Svenska AB Box 962  
S-18 109 Lidingö (SE)**

**EP 0 068 111 B1**

Note: Within nine months from the publication of the mention of the grant of the European patent, any person may give notice to the European Patent Office of opposition to the European patent granted. Notice of opposition shall be filed in a written reasoned statement. It shall not be deemed to have been filed until the opposition fee has been paid. (Art. 99(1) European patent convention).

## Description

This invention relates to method of forming a cathode structure.

Cathodes have been prepared for many years using the alkaline earth oxides of appropriate crystal structures to give electron emission when heated to 700—1100°C. The oxides are very sensitive to cathode poisoning which is believed to close off the fine porous structure that aids electron emission. For optimum emission, the industry uses controlled composition mixed CaSrBa carbonates, (known as triple carbonate). The carbonate breaks down during the initial heating of the cathode in vacuum during the evacuation and seal-off of the cathode ray tube (CRT) or the vacuum tube. The formation of the oxide (sometimes termed thermal activation) from the carbonate, is performed while the excess  $\text{Co}_2$  is being pumped away. Illustratively, the oxides are sensitive to water vapour which damages the triple oxide crystal structures. Hence, the industry prefers carbonate deposition plus later decomposition to the oxides.

Normally, the carbonates for both electron tubes and cathode ray tubes are sprayed or dipcoated onto the cathode structure, and an organic binder is used to make the carbonate particles stick to the cathode metal substrate. These binders are often based on polymethacrylate or nitrocellulose and are chosen because they leave the carbonate crystal morphology intact after they are "burned-off", during the initial heating of the thermal activation step.

A background reference concerning the foregoing is: Handbook of Materials and Techniques for Vacuum Devices, by W H Kohl, Reinhold Publishing Corp., 1967.

Very few instances of patterned cathodes have been reported in the background literature. Generally, the design of devices did not require it. Some work has been reported on a photoresist process for patterning triple carbonates. This includes Stanford Research Institute Quarterly Report No. 3 dated Nov. 15, 1968, on Low Temperature Thermionic Emitter prepared for NASA on contract 12—607, by D U Geppert et al which describes cathode coatings on coplanar diode vacuum devices. The method reported in the Quarterly Report, No. 3 provides accurate patterning of triple carbonates. The method uses a negative thin film resist. Carbonate particles are loaded into the photoresist (up to 75% solids content) and milled in a ball mill to produce a slurry of appropriate viscosity to be spin coated on a cathode. Typically, 70% CaSrBa carbonate crystals are incorporated into Kodak photoresist and exposed to conventional photo sources. To avoid poor resolution, the mixtures are heavily ball milled. The typical image sizes of fractions of a mill are not adequate for practice of this invention. The Stanford Research Institute loaded photoresist method has several difficulties which restrict the application of the technology to finer

limits. Practice of this method has the following attendant problems:

(a) difficulty in locating wafer registration marks through opaque resist;

(b) poor resolution because of light scattering of solids;

(c) difficulty of spinning loaded resists;

(d) solid residues left of the developed areas need an undercoat of pure resist to avoid extraneous emission therefrom;

(e) there is a layer or residue of the resist layer between emission layer and metal of cathode;

(f) as the triple carbonate is in the surface of the resist, it is exposed to contamination e.g., by gases, causing subsequent loss of emission;

(g) and the heavy ball milling of the carbonate particles necessary to reduce the crystal size in order to achieve improved resolution, adversely affects the emission efficiency (large carbonate crystals are used to give open oxide structures).

Triple carbonates of appropriate crystal size can be brought commercially. Background reference is in chapter 16, of the Handbook by W H Kohl entitled "Cathodes and Heaters". Filamentary cathode emitters which were coated with alkaline-earth carbonates by cataphoresis (cathode deposition by electrophoresis) are described on page 514 of the Handbook.

The prior art practice has provided micro-miniature planar cathode-grid structures for vacuum tubes in which the principles of this invention can be beneficially applied. Illustrative of such structures are those disclosed in US No. 4,138,622 and EP—0039877.

The devices referred to require triple carbonate patterns precisely and clearly delineated because the grid is virtually in the same plane and on the same substrate surface as the cathode. If there is any spurious imprecise pattern of carbonate deposition, there is a risk of anomalous uncontrolled grid emission because the grid is at the same temperature 700—1100°C as the cathode metal. The ultimate technological limit of micro-miniaturization to which these devices can be pushed depends on the critical patterning resolution of the carbonate particles.

It is an object of this invention to provide an intermediate encapsulated cathode structure to minimize or avoid manufacturing environmental damage or poisoning.

It is another object of this invention to obtain high emission density from a cathode structure by utilizing large needle crystals established essentially normal to a substantially planar surface.

The invention is particularly applicable to microcathodes, and, in particular, to microcathodes for multibeam cathode ray tubes.

A method of forming a cathode structure, according to this invention, comprises the steps of establishing a first positive photoresist layer on a metallization layer on a substrate forming a delineated aperture in the positive photoresist layer to expose an area of the metallization layer, depositing electron emissive material in the

apertures, establishing a second layer of positive photoresist over the electron emissive material and the first layer of photoresist, removing part of both layers of photoresist to form a region of the two photoresist layers which encapsulates the electron emissive material, and heating the region of the two photoresist layers and electron emissive material to leave a residue of electron emissive material on the metallization at the aperture location.

In accordance with an embodiment of this invention, electrophoresis is used for depositing large needle crystals of triple carbonate to produce good orientation and good crystal packing in an electron emissive layer.

In particular a cataphoretic deposition solution is prepared by ball milling carbonate particles, e.g. triple carbonate particles with a needle structure, in an ethyl alcohol liquid for sufficient time that a surface charge appears on the broken crystals. This surface charge is used to make the particles move under the influence of the applied electric field obtained by voltage applied to the workpiece. The deposit fills the apertures in the resist, and of necessity the photoresist is an appropriate electrical insulator. A beneficial resolution is obtained because the particles are standing on end and the cross-section which occupies an area of the surface is of much smaller section than the longitudinal section. Therefore, the resolution will be much higher for equivalent size particles.

Thus, there is accomplished in the practice of this invention cataphoretic coating into an aperture in a mask where the mask is now subject to the photolithography limits of an ordinary transparent film, rather than a carbonate loaded film of the prior art. This yield gives significantly better resolution than with a loaded photoresist. The triple carbonate particles come in end on into the aperture as needle structures which are essentially normal to a planar surface. The cathode structure with the electron emissive layer is obtained *in situ* in the vacuum tube by heating the encapsulated pattern therein.

A multiple electron beam cathode ray tube for which a cathode structure according to the invention is particularly suitable, has a plurality of cathodes in a plane positioned on one side of a substrate to form an array. An advantageous embodiment thereof is disclosed in EP—0039877.

Grids in the same plane, i.e. on the surface of the same substrate, are positioned in spaced relation about the cathodes. A heater is associated with the substrate for heating the cathodes. The resultant unitary structure is mechanically stable and operative with small grid-to-cathode voltages, for example, less than 35 volts, and negligible grid currents so that a plurality of individually controlled electron beams are formed when appropriate potentials are applied to the cathodes and grids. The structure can be batch-fabricated with photolithography to define accurately the distance between the cathode and the grid as well as the size of the

cathode. The electron emissive layers of the cathodes of a multibeam CRT may be obtained in accordance with this invention.

The invention is hereinafter described with reference to the accompanying drawings, in which;

Figs. 1.1 to 1.5 illustrate the steps of a prior art method of forming an electron emissive surface;

Figs. 2.1 to 2.6 illustrate the steps involved in one example of a method according to this invention;

Fig. 3 illustrates a multiple electron beam cathode ray tube for which a cathode structure made according to this invention is particularly suitable;

Fig. 4 is a fragmentary cross-sectional view showing a unitary grid and cathode array structure made according to this invention in the cathode ray tube of Fig. 3;

Fig. 5 is a plan view of a wafer substrate during the preparation of a multi-cathode structure according to the invention;

Fig. 6 is a sectional view on the line VI—VI of Fig. 5;

Fig. 7 is a view similar to Fig. 5 at a later stage in the preparation, with two layers broken away for clarity; and

Fig. 8 is a sectional view on the line VIII—VIII of Fig. 7 upon completion of the preparation.

In the first step 1 of the prior art method illustrated in Fig. 1.1, a metallization layer 10 is deposited on and supported by a substrate 14 at interface 15 and has an outer surface 12. A very thin layer 16 of pure negative photoresist is established in step 2 (Fig. 1.2) on surface 12 of layer 10 and has an outer surface 18. In step 3 (Fig. 1.3), a layer 20 of triple carbonate loaded negative photoresist is established on surface 18 of layer 16 and has an outer surface 22. Resist layer 20 is exposed to a selected pattern via a light mask (not shown) in step 4 (Fig. 1.4) leaving a developed pattern 24 in the combined residue of thin layer 16 and triple carbonate loaded photoresist 22 comprising resist 24.1 and carbonate particles 24.2. The boundaries of pattern 24 are its upper surface 26, left boundary 28.1 and right boundary 28.2. Finally, in step 5 (Fig. 1.5), the resist 24.1 is "burnt off" by heating prior to or concurrent with the carbonate breakdown that gives the required CaSrBa oxide pattern 30 on substrate 10. If the heating is slow, the resist tends to melt and spread, spoiling the definition of the pattern. If the heating is fast, the resist vaporises and gives rise to poor adherence of the oxide pattern.

In the first step 1 of an exemplary method according to this invention illustrated in Fig. 2.1 which step is similar to that of Fig. 1.1, a cathode substrate 7 supports, at interface 9, a metallization layer 11 with upper surface 13. As an example, a sapphire wafer is evaporated with metallization tungsten 400 nm and titanium 100 nm. A positive photoresist layer is deposited on the surface 13, and, in step 2, (Fig. 2.2) through positive photoresist technology by exposing and

developing photoresist, aperture 40 is established in layer 42 leaving resist segment 42.1 on the left and resist segment 42.2 on the right. Aperture 40 defines a segment 41 of the metallization layer 11. The photoresist is insulating and novalac resins are suitable.

In step 3 (Fig. 2.3), a pattern 44 of electron emissive material CaSrBa carbonate is cathodically deposited in aperture 40. The material is comprised of elongated particles in the form of needle-like structures. A substantial proportion of the carbonate needles 44.1 is aligned essentially perpendicular to metallization segment 41. As described below, barium formate solution 44.2 is added and the solvent driven off to improve adhesion of the needles to the metallization layer.

A thick capping layer 46 of positive resist is established in step 4 (Fig. 2.4) over carbonate pattern 44 and also over the adjacent photoresist segments 42.1 and 42.2. Thereafter, in step 5 (Fig. 2.5), both positive photoresist layers 46 and 42 are exposed and developed through use of a larger aperture light mask than for step 2, leaving a pedestal 48 comprising side encapsulation 48.1 originally part of segment 42.1, side encapsulation 48.2 originally part of segment 42.2, photoresist 48.3 originally part of layer 46 and carbonate pattern 44. Finally, in step 6 (Fig. 2.6), the photoresist of pedestal 48 is "burnt off" during carbonate decomposition leaving the required CaSrBa oriented oxide pattern 50. Between steps 5 and 6, the substrate 7 with the pedestal-encapsulated carbonate pattern may be inserted into a vacuum tube as a cathode.

The method described in relation to Figs. 2.1 to 2.6 has the following advantages:

- 1 Residual sedimented, or noncathodically coated carbonate, is removed during final resist development except for the interface area A.
- 2 Because of greater photolithographic accuracy, cathode shape is better delineated by use of unloaded positive photoresist and electrophoresis process than by use of a loaded resist technology, as described in relation to Figs. 1.1 to 1.5.
- 3 Because cathode coating 50 is in contact with substrate metal, there is better adhesion, and eventually after thermal activation better electrical contact of the semiconducting CaSrBa oxide crystals.
- 4 Larger crystals 44.1 give better emission than the particles obtained by the method described in relation to Figs. 1.1 to 1.5, because heavy ball milling is not required for photoresolution.
- 5 Oriented crystals 44.1 give better emission, structure, open packaging, and crystallites from top to bottom of emissive layer, with attendant shape/field enhancement.
- 6 Because photoresist binder 48.3 is on top of pattern 44, better adhesion is obtained to layer 11 during breakdown.
- 7 Contamination is avoided during inclusion in

the vacuum tube because of the encapsulation pedestal 48.

- 8 Encapsulated cathode material allows more rugged handling of the cathode structure. This allows or helps subsequent wafer operations after carbonate coating such as, welding, scribing, and dicing.

A cathode made in accordance with the invention may be used advantageously in a multiple electron beam cathode ray tube 60 (Fig. 3). The tube 60 has an envelope 62, fluorescent screen 64, means 66 for accelerating focussing and deflecting electron beams, and a unitary structure 68 (Fig. 4) which is situated in the neck portion of envelope 62. As schematically illustrated, the unitary structure 68 is connected to a source 70 of electrical input signals by a plurality of wires in bundles 72 and 74.

The unitary structure 68 (Fig. 4) has a substrate 76 of a high temperature insulator, such as sapphire, with good thermal conductivity. On the back surface of the substrate 76 is a thin film heater 78 made from a resistive, refractor metal, such as tungsten or molybdenum. Positioned on the front surface of the substrate 76 is an array of cathodes 80A, 80B and 80C, that are surrounded by modulating grids 82A, 82B and 82C, that are surrounded by modulating grids 82A, 82B and 82C, respectively. The arrays of cathodes 80A to 80C and grids 82A to 82C are on the same surface which is in a single plane.

The cathodes and the grids need to be on the same surface but it is not essential that the surface be planar. The cathodes could be recessed with respect to the grids. A wire 73 from the bundle 72 goes from the source 70 to one end of the heater 78 and a wire 75 from the bundle 74 goes from the other end of the heater 78 to the source 70.

The other wires from bundles 72 and 74 which go to the cathodes and to the grids are not shown.

The unitary structure 68 can be batch-fabricated with photolithographic process steps. Illustratively, the cathodes 80A to 80C are deposited on the front surface of substrate 78 as a thin film of molybdenum, tungsten, platinum or other suitable refractory material and then defined by conventional photolithographic techniques. The cathode areas are then made electron-emitting by delineating a mixture of photoresist and carbonates of strontium, barium and calcium in those regions in accordance with this invention. When the substrate is heated in a vacuum to a temperature of approximately 1000°C, the photoresist volatilizes at about 500°C leaving the cathodes electron emitting and capable of being activated in the usual manner by applying the appropriate voltage. This batch-fabrication method is capable of very fine dimensional control providing the capability of making cathode and grid lines as small as 10 microns in width.

In operation, the thin film heater 78 heats the substrate 76 to a temperature of the order of

700°C so that sufficient electron emission takes place. The cathodes are then individually biased with respect to the grids to either cut off or turn on. Alternatively, adjacent grid electrodes, for example, 82B and 82C, may be replaced by a single grid electrode.

Figs. 5, 6, 7 and 8 illustrate a method of obtaining several cathodes commonly connected electrically during the cataphoresis of the triple carbonate. For mass production, the conventional integrated circuit wafer chip approaches of silicon are utilized. The electrical circuits which comprise the cathodes must be electrically isolated from the grids for device operation. However, in order to perform cataphoretic coating, all the cathodes on the chip should be electrically connected in common. Otherwise individual contacting of each cathode is required on opposite edges of the chip. There can be obtained a grid connection from one chip to the cathode pad on the next chip which occurs between every pair of chips on the wafer. Thus, the adjacent chips are used to provide the electrical connection mechanism, for commoning up all the cathodes on one chip. When the chips are separated, the connections that go from a cathode pad to the adjacent grid are broken, thereby providing the isolation which is necessary for each cathode from each grid in the use of the device as a cathode ray tube.

On a circular sapphire wafer substrate 7.1 (Fig. 6), a metallization layer 11.1 is deposited with its periphery spaced by a distance D from the periphery 17 of the wafer. A pattern of the layer 11.1 adjacent the cathode sites is removed. A positive photoresist layer 42.3 is deposited on the layer 11.1 and substrate 7.1, and, by exposure and development, apertures 40.1, 40.2, 40.3 and 40.4 are formed in the layer 42.3. Electron emission layers 50.1, 50.2, 50.3 and 50.4 in the form of needle-like particles of carbonate are cataphoretically deposited in the apertures 40.1, 40.2, 40.3 and 40.4, respectively, upon exposed areas 41.1, 41.2, 41.3 and 41.4 of the metallization layer 11.1. When cataphoresis occurs, by having the metallization 11.1 spaced from the edge of the substrate 7.1 with resist 42.3 over the entire surface, there is no sharp edge to gain and intensify the electric field. Therefore, the electric field is uniform over the cathode areas 40.1 to 40.4 and the process of depositing the electron emissive layers can be quantified both as to time and current.

The shapes of the pattern of metallization layer 11.1 removed are such as to almost surround each cathode area leaving a narrow connecting strip of metallization. Thus when the resist 42.3 is deposited, moats 53.1 to 53.4 (Fig. 7) are formed around emission layers 50.1 to 50.4 and leads 51.1 to 51.4, respectively.

A further layer 46.1 of positive photoresist is established over the resist layer 42.3 and over the emissive layers 50.1 to 50.4. Both layers 42.3 and 46.1 are exposed and developed through the use of a larger aperture light mask, leaving pedestals 48.13 and 48.14 encapsulating the top and sides

of the emissive layers 50.3 and 50.4, respectively. Emissive layers 50.1 and 50.2 are also encapsulated by those pedestals.

Ultimate chip 55 (Fig. 7) is defined by boundaries 55.1 to 55.4. Remaining exposed metallization 57 serves as a grid for the cathodes. Although shown connected, it may also be partitioned into separate grids as discussed hereinbefore. After preparation, the ultimate chip 55 is severed along boundaries 55.1 to 55.4 from the remainder of substrate 7.1 and metallization 11.1. Each of the four cathode regions 50.1 to 50.4 has a conductor lead 51.1 to 51.4 to the edge of the chip. Each cathode and lead on the chip 55 is surrounded by a nonconductive region, e.g. cathode 50.1 and lead 51.1 is surrounded by a nonconductive region or moat 53.1. Once the ultimate chip 55 is severed along boundaries from the remainder of substrate 7.1 and metallization 11.1, the product is inserted in a cathode ray tube. The requirements of the tube determine the number of cathodes on the chip or the number of chips.

The chips may be used in a cathode ray tube such as disclosed in EP—0039877, in which electrodes on the surface of the substrate are connected to bonding pads respectively. This permits each one of the electrodes to be individually controlled. The grids are all connected to the grid bonding pad thereby resulting in a potential to the grid which is constant. Another multibeam CRT embodiment with which this invention may be practised has the grids individually connected to separate bonding pads so that the potential to each grid can be individually controlled. The potentials may be individually modulated between each cathode and the grid immediately surrounding that cathode. This may be done by maintaining the grid constant and individually controlling the cathode potentials, by maintaining the cathode potential constant and individually varying the grids, or by individually controlling the potential of each cathode and the potential of each grid.

The configuration of each planar grid for each cathode may be in the shape of a C that surrounds a circular cathode. Another geometry of a grid-cathode design, one of which cathodes are in the form of a cross and a planar grid surrounds a plurality of cathodes.

The geometry of a multibeam CRT described hereinabove and illustrated by the drawings and the method of fabrication thereof have a number of advantages. The use of photolithography defines the critical dimensions between the cathode and for fabrication of cathodes and grids of a multibeam CRT for the practice of this invention the grids which determine the electron gain as well as providing high resolution cathodes. The small grid-cathode spacing achievable with photolithography gives a large transconductance and small grid-to-cathode voltages. The coplanar grid provides a rugged construction with no microphonics and with very little if any grid current. The cathode/grid and heaters are fabricated as one integrated assembly which is a

5

10

15

20

25

30

35

40

45

50

55

60

65

5

mechanically stable structure. In addition, the use of photolithography allows many cathode-grid arrays to be fabricated at the same time thereby resulting in a substantially lower cost per unit.

The use of positive photoresist in a process according to the invention, enables the undeveloped portions of the photoresist layer (for example 42.1 and 42.2) to be later exposed and developed to leave part of the metallization layer uncovered.

Catophoresis is a particular form of electrophoresis. Suspensions for electrophoresis in this invention may be prepared in many ways. The essential feature is to get a charge onto the surface of the particle. This is usually achieved by ball milling the triple carbonate in a solvent of low electrical conductivity in the presence of a slight amount of freely ionized additive. As the crystals break due to milling, the highly reactive fresh breakage surface created absorbs the ions. This gives a charged particle capable of being moved and deposited by electrophoresis. A recipe for an electrophoretic cathode carbonate suspension will now be described.

Pour 200 to 250 millilitres of 80% ethyl alcohol and 20% methyl alcohol into a one-pint porcelain mixing jar and add a ball charge of 30 to 38 grammes (9 to 11 balls). Add the 10 to 15 grammes of coating precipitate, seal the jar and place into mixing equipment for 24 hours to 48 hours at 67 r.p.m. Remove the mixing jar from the mixing equipment. The coating precipitate is left in suspension with the industrial spirit inside this jar and is shaken up before use. The quantities referred to will yield approximately 50 grammes of coating precipitate.

The ions may be supplied by the limited solubility of the carbonate precipitate in the nonconducting solvent. Pure demineralized distilled water, methyl ethyl alcohols or organic esters can be used as insulating dispersants.

The suspension example cited hereinbefore coats cataphoretically at between 10V to 100V per time period of 3 secs to 30 secs. The exact voltage and time are determined experimentally. Smooth deposits are achieved by the use of lower voltages. Needle-shaped particles which are very beneficial as cathode sources in accordance with this invention, have the added advantage that they deposit in a way that gives an oriented deposit with the long axis virtually normal to the surface being coated. The cataphoretic-deposit is quite soft and easily damaged. An adhesion promoter, such as barium formate solution in water may be added. The deposit is dipped into the solution and then dried. Alternatively, a small percentage, e.g. 2% to 5% of barium formate may be milled into the initial electrophoretic suspension. The barium formate is chosen because it melts and decomposes to barium carbonate. In so doing, it promotes adhesion of carbonate particle to particle and to the cathode metallization without loading the cathode coating with poisons or diluents.

For cataphoresis, a voltage source (not shown)

is connected into the exposed cathode metallization, for example, 25 volts for 5 secs.

Illustratively, the cataphoretic deposition is baked at 80°C for 5 mins.

The baked cataphoretic deposition is dipped in barium formate saturated water solution and rebaked to promote adhesion of carbonate particles to each other and to the substrate.

## Claims

1. A method of forming a cathode structure, comprising the steps of establishing a first positive photoresist layer on a metallization layer (11) on a substrate (7), forming a delineated aperture (40) in the positive photoresist layer to expose an area (41) of the metallization layer, depositing electron emissive material (44) in the aperture, establishing a second layer (46) of positive photoresist over the electron emissive material and the first layer of photoresist, removing part of both layers of photoresist to form a region (48) of the two photoresist layers which encapsulates the electron emissive material, and heating the region (48) of the two photoresist layers and electron emissive material to leave a residue (50) of the electron emissive material on the metallization at the aperture location.

2. A method according to claim 1, in which the electron emissive material is of carbonate.

3. A method according to claim 2, in which the carbonate is a triple carbonate.

4. A method according to claim 1, 2 or 3, in which the electron emissive material is in the form of elongated, needle-like particles (44.1).

5. A method according to claim 4, in which a substantial proportion of the particles is aligned essentially normal to the metallization.

6. A method according to claim 2 or any claim appendant thereto, in which the material is deposited by electrophoresis.

7. A method according to claim 6, in which the electrophoresis is cataphoresis.

8. A method according to claim 1, in which the step of heating the region (48) of the two photoresist layers is performed after said structure has been inserted into a vacuum tube as a cathode.

## Patentansprüche

1. Verfahren zur Herstellung einer Kathodenstruktur, das die folgenden Schritte einschliesst: Herstellung einer ersten positiven Photoresist-Schicht auf einer Metallisierungsschicht (11) auf einem Substrat (7); Bildung einer entworfenen Öffnung (40) in der positiven Photoresist-Schicht, so dass ein Bereich (41) der Metallisierungsschicht freigelegt ist; Niederschlag eines Elektronen-emissierenden Stoffes (44) in der Öffnung; Herstellung einer zweiten aus einem positiven Photoresist bestehenden Schicht (46) auf dem Elektronen-emissierenden Stoff und der ersten Photoresist-Schicht; Entfernung eines Teiles der beiden Photoresist-Schichte zur Bildung eines Bereichs (48) der beiden

Photoresist-Schichte, in dem das Elektronen-emissierende Stoff gekapselt ist und; Erwärmung des Bereichs (48) der beiden Photoresist-Schichte und des Elektronen-emissierenden Stoffes, so dass ein Rückstand (50) des Elektronen-emissierenden Stoffes auf der Metallisierungsschicht an der Stelle der Öffnung zurückbleibt.

2. Verfahren nach Anspruch 1, wobei das Elektronen-emissierenden Stoff aus Carbonat besteht.

3. Verfahren nach Anspruch 2, wobei das Carbonat ein Dreifachcarbonat ist.

4. Verfahren nach Anspruch 1, 2 oder 3, wobei das Elektronen-emissierende Stoff in der Form von gedehnten nadelförmigen Teilchen (44.1) besteht.

5. Verfahren nach Anspruch 4, wobei ein wesentlicher Anteil der Teilchen im wesentlichen senkrecht zu der Metallisierungsschicht angeordnet ist.

6. Verfahren nach Anspruch 2, oder nach irgendeinem der von diesem Anspruch abhängigen Ansprüche, wobei das Stoff mittels Elektrophorese niedergeschlagen ist.

7. Verfahren nach Anspruch 7, wobei die Elektrophorese eine Kataphorese ist.

8. Verfahren nach Anspruch 1, wobei der Schritt der Erwärmung des Bereichs (48) der beiden Photoresist-Schichte erfolgt, nachdem die Struktur in einer als Kathode wirkenden Vakuumröhre hineingeführt ist.

#### Revendications

1. Une méthode de formation d'une structure de cathode comprenant des étapes d'établissement d'une première couche de photoresist positif sur une couche de métallisation (11) sur un substrat (7) de formation d'une ouverture

délimitée (40) dans la couche de photoresist positif afin d'exposer une zone (41) de la couche de métallisation, de dépôt de matériau émetteur d'électrons (44) dans l'ouverture d'établissement d'une seconde couche (46) de photoresist positif sur le matériau émetteur d'électrons et la première couche de photoresist, de retrait partiel des deux couches de photoresist pour former une région (48) des deux couches de photoresist, qui emprisonne le matériau émetteur d'électrons et de réchauffement de la région (48) des deux couches de photoresist et du matériau émetteur d'électrons afin de laisser un reste (50) de matériau émetteur d'électrons sur la métallisation à l'emplacement de l'ouverture.

2. Une méthode selon la revendication 1 dans laquelle le matériau émetteur d'électrons est du carbonate.

3. Une méthode selon la revendication 2 dans laquelle le carbonate est un triple carbonate.

4. Une méthode selon la revendication 1, 2 ou 3, dans laquelle le matériau émetteur d'électrons se présente sous la forme de particules allongées en forme d'aiguilles.

5. Une méthode selon la revendication 4 dans laquelle une proportion substantielle des particules est alignée pratiquement normalement à la métallisation.

6. Une méthode selon la revendication 2 ou toute revendication dépendant de celle ci, dans laquelle le matériau est déposé par électrophorèse.

7. Une méthode selon la revendication 6 dans laquelle l'électrophorèse est une cataphorese.

8. Une méthode selon la revendication 1 dans laquelle l'étape de réchauffage de la région (48) des deux couches de photoresist est exécutée après que ladite structure ait été introduite dans un tube à vide comme cathode.

5

10

15

20

25

30

35

40

45

50

55

60

65

7

PRIOR ART

FIG. 1.1

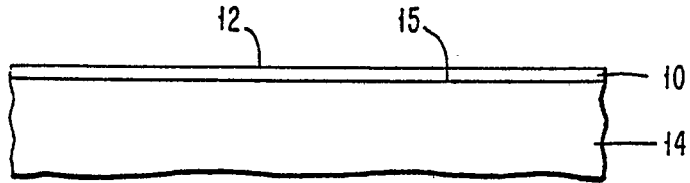

FIG. 1.2

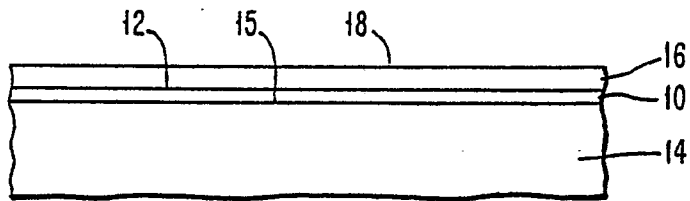

FIG. 1.3

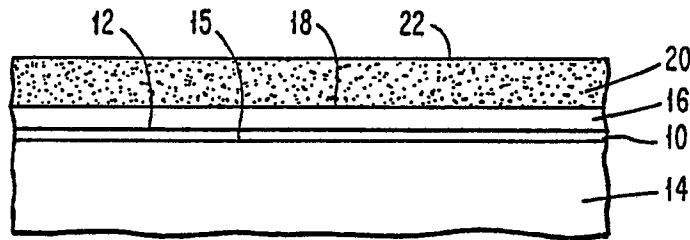

FIG. 1.4

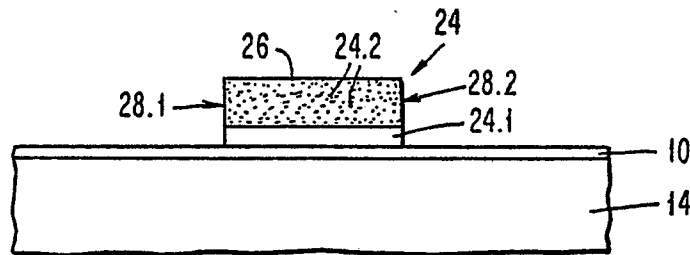

FIG. 1.5

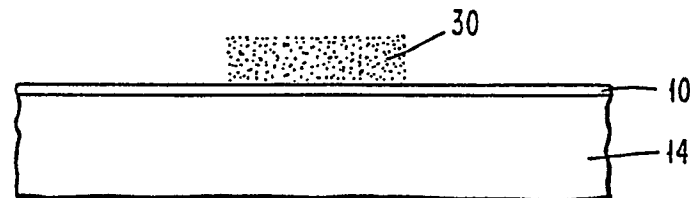

FIG. 2.1

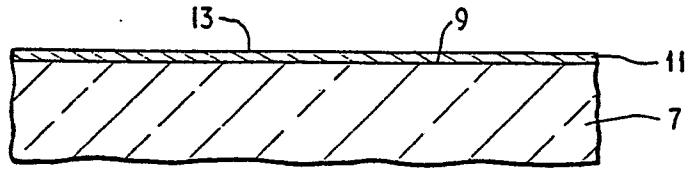

FIG. 2.2

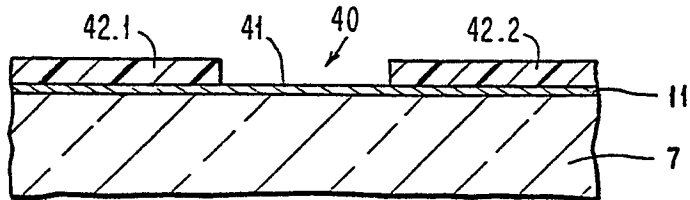

FIG. 2.3

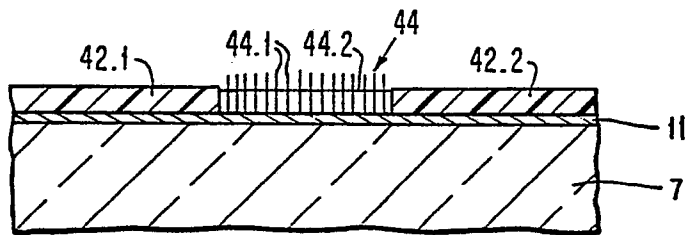

FIG. 2.4

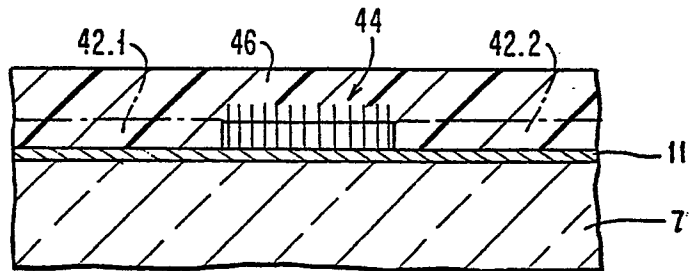

FIG. 2.5

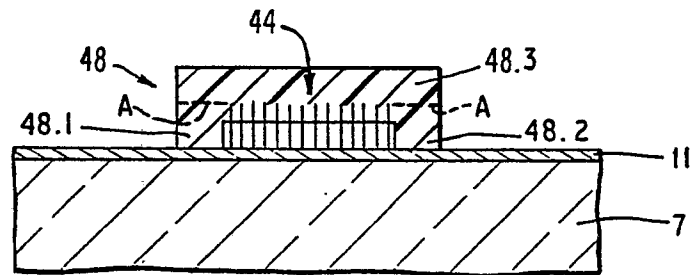

FIG. 2.6

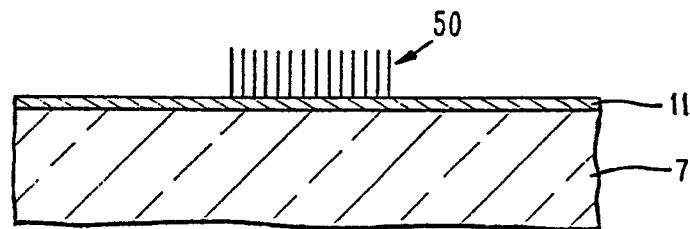

FIG. 3

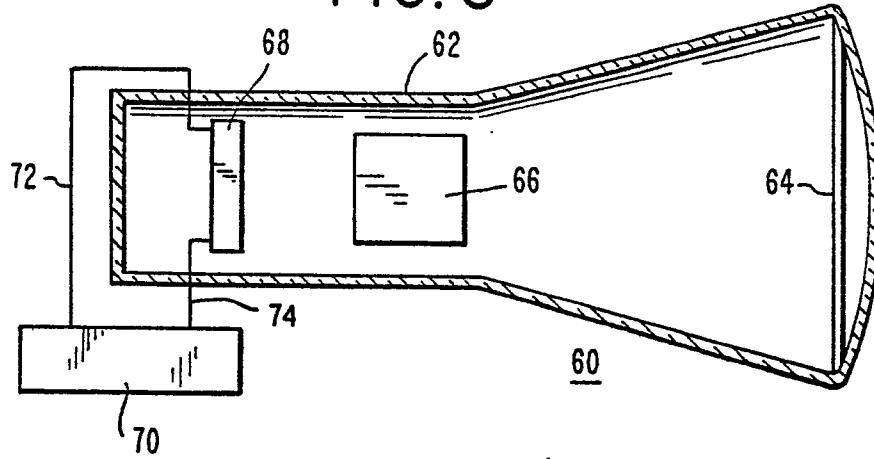

FIG. 4

