

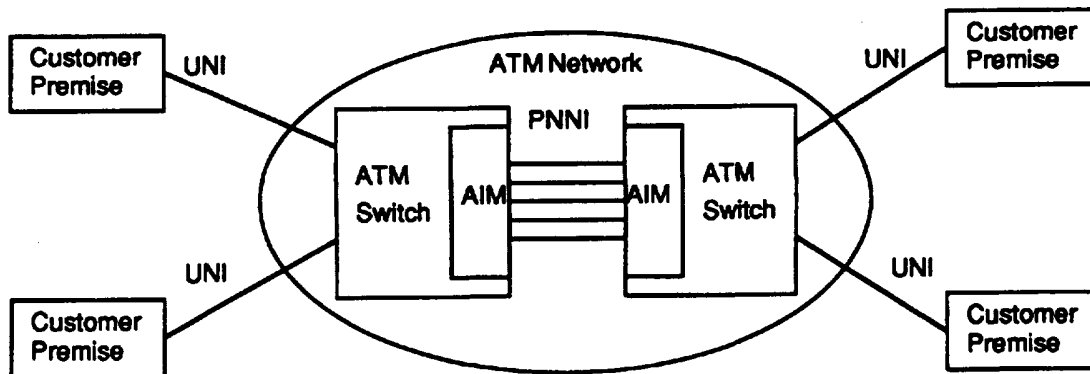

INTERNATIONAL APPLICATION PUBLISHED UNDER THE PATENT COOPERATION TREATY (PCT)

<p>(51) International Patent Classification ⁶ : H04Q 11/04</p>	<p>A1</p>	<p>(11) International Publication Number: WO 96/17489 (43) International Publication Date: 6 June 1996 (06.06.96)</p>
<p>(21) International Application Number: PCT/CA95/00322 (22) International Filing Date: 2 June 1995 (02.06.95) (30) Priority Data: 08/350,092 29 November 1994 (29.11.94) US (71) Applicant: NORTHERN TELECOM LIMITED [CA/CA]; World Trade Center of Montreal, 8th floor, 380 St. Antoine Street West, Montreal, Quebec H2Y 3Y4 (CA). (72) Inventors: VALLÉE, Richard; 67 rue Castillou, Gatineau, Quebec J8T 5Y4 (CA). ELLIS, John, G.; 56 Rosenfeld Crescent, Kanata, Ontario K2K 2H6 (CA). (74) Agent: TOYOOKA, Yoshiharu; Northern Telecom Limited, Patent Dept., P.O. Box 3511, Station "C", Ottawa, Ontario K1Y 4H7 (CA).</p>		<p>(81) Designated States: CA, JP, European patent (AT, BE, CH, DE, DK, ES, FR, GB, GR, IE, IT, LU, MC, NL, PT, SE). Published <i>With international search report.</i></p>

(54) Title: ATM INVERSE MULTIPLEXING



(57) Abstract

In ATM networks, digital data in ATM cells are sent to a destination node over more than one transmission link in round robin fashion. This is called inverse multiplexing. At connection start-up, the source node informs the destination node of the specific round robin fashion of the transmission links so that the ATM cells are reassembled in a proper sequential order.

FOR THE PURPOSES OF INFORMATION ONLY

Codes used to identify States party to the PCT on the front pages of pamphlets publishing international applications under the PCT.

AT	Austria	GB	United Kingdom	MR	Mauritania
AU	Australia	GE	Georgia	MW	Malawi
BB	Barbados	GN	Guinea	NE	Niger
BE	Belgium	GR	Greece	NL	Netherlands
BF	Burkina Faso	HU	Hungary	NO	Norway
BG	Bulgaria	IE	Ireland	NZ	New Zealand
BJ	Benin	IT	Italy	PL	Poland
BR	Brazil	JP	Japan	PT	Portugal
BY	Belarus	KE	Kenya	RO	Romania
CA	Canada	KG	Kyrgyzstan	RU	Russian Federation
CF	Central African Republic	KP	Democratic People's Republic of Korea	SD	Sudan
CG	Congo	KR	Republic of Korea	SE	Sweden
CH	Switzerland	KZ	Kazakhstan	SI	Slovenia
CI	Côte d'Ivoire	LI	Liechtenstein	SK	Slovakia
CM	Cameroon	LK	Sri Lanka	SN	Senegal
CN	China	LU	Luxembourg	TD	Chad
CS	Czechoslovakia	LV	Latvia	TG	Togo
CZ	Czech Republic	MC	Monaco	TJ	Tajikistan
DE	Germany	MD	Republic of Moldova	TT	Trinidad and Tobago
DK	Denmark	MG	Madagascar	UA	Ukraine
ES	Spain	ML	Mali	US	United States of America
FI	Finland	MN	Mongolia	UZ	Uzbekistan
FR	France			VN	Viet Nam
GA	Gabon				

ATM INVERSE MULTIPLEXING

Technical Field and Industrial Application

The invention relates to a new mechanism for sending ATM
5 cells transparently over multiple slower transmission links. In
particular, the invention is directed to a method of inverse
multiplexing of a series of ATM cells transparently over N
transmission links (N being a positive integer) of slower speed.

10 Background Art

It has been recognized that the T1/E1 rate (1.544/2.048 Mbit/s) is a
cost effective way of user access to an ATM network as well as
connection between ATM network switches. However, as ATM
technology for wide area networks is deployed more and more,
15 demands for transmission links of a rate higher than T1/E1 are
increasing. Links of higher rates, such as T3/E3 (44.736/34.368 Mbit/s),
have been designed to meet these needs. However, the cost of T3/E3
links is still prohibitive in many cases and the ratio of cost versus
realistic utilization of the entire rate is not always attractive and fully
20 justified for new ATM end users and service providers. ATM inverse
multiplexers (AIMs) have been proposed to satisfy the need by using
multiple T1/E1 links which are grouped collectively to provide the
service at a higher rate.

Figure 1 and Figure 2 show two sample configurations in which
25 AIMs are used. Figure 1 depicts a user access to a network through
user network interfaces (UNIs) and Figure 2 a link connection between
ATM switches through broadband inter-carrier interfaces (BICIs) or
private network to network interfaces (PNNIs).

Referring to the figures, the basic function of AIMs is to work in
30 pairs to take an ATM cell stream coming from the ATM layer, send it
over the multiple links by spreading cells over the available links and
ensure that the initial cell stream can be retrieved at the far end. Thus
the AIMs preferably make the ATM traffic transparent to the ATM
layer over multiple links which connect them. As far as the ATM layer
35 is concerned, it should only see a pipe whose rate is now the sum of the
multiple link rates. It is assumed that each link is run in clear-mode
without the presence of intermediate ATM nodes processing ATM

cells. This means that there should be no cell discard by any intermediate transmission equipment.

Currently no ATM inverse multiplexing protocols have been proposed which can properly interwork existing ATM inverse
5 multiplexers or other ATM products which are already available on the market, and yet are flexible enough to fit into the current standard ATM specifications. Two proposals for an ATM inverse multiplexing protocol have so far been made and are described in detail below.

10 New Transmission Convergence Protocol Using GFC Bits

This protocol was presented in "Physical Layer Sub-Working Group ATM Forum/94-0775, ATM Inverse Multiplexing Mechanism", September 1994, by StrataCom Inc. The protocol robs two of the Generic Flow Control (GFC) bits contained in each cell transmitted
15 over the multiple T1/E1 links to implement a new transmission convergence (TC) layer. Figure 3 shows the ATM cell structure which is defined in the ITU Recommendation. The TC layer is defined by one GFC bit for framing and the other one for link control. The framing bit is used to determine relative link delays while the link control bit is
20 used for communication, control and administration between two TC points at two ends of the inverse multiplexer.

In order to establish the sequence of cells over the links in a round robin manner, one end is defined as being "master" and the other as "slave". The "master" decides and informs the slave about the
25 multiple link configuration using the control channel implemented through the link control bits.

This protocol is only applicable, however, for UNI application points because GFC bits that are robbed to implement the TC layer are only present in a cell defined for UNI. For NNI cells, the
30 corresponding bits are no longer available since they are captured under the VPI field. Service providers are interested in ATM inverse multiplexers for carrying ATM traffic at rates higher than T1/E1 and lower than T3/E3, but this protocol will not satisfy their need. It should also be noted that the protocol calls for a need to identify a
35 "master" and a "slave" TC point and that requires an additional setting to be performed by the network operator.

Bit Pipe Inverse Multiplexing

This protocol was presented in "Physical Layer Sub-Working Group ATM Forum/94-0956, Inverse Multiplexing of ATM cells over low speed UNIs such as T1 and E1", September 1994, by Digital Link Corporation. It proposes a "bit pipe" inverse multiplexing technique requiring the definition of a "bonding" (bandwidth on demand) like specification for N (positive number) T1/E1 inverse multiplexing.

It is not clear in the proposal how both ends of the links exchange information concerning the order of cells to be transferred from one end to another over multiple links. The proposal mentions the existence and deployment of physical layer protocols that perform inverse multiplexing. The inverse multiplexer which can be used in this proposal is presumably the one defined by Digital Link Corporation in their "DL3800 DS1 Inverse Multiplexer Users Manual, 1993".

The inverse multiplexing protocol defined in the above user's manual relies on the definition of an extra bit taken from T1/E1 payload bits to configure the multiple links and adjust differential link delays. This protocol introduces the need for extra processing of data between devices dealing with T1/E1 frames and ATM cell delineation. It also causes the ATM cells to no longer be byte aligned with the DS1/E1 frame. This is a requirement by the ATM Forum UNI DS1/E1 Physical Layer specifications. Changes like this would not be welcome by end users, vendors and service providers who are already using and deploying ATM equipment.

Objects of the Invention

It is therefore an object of the invention to provide a method of sending ATM traffic over a connection consisting of a plurality of transmission links.

It is another object of the invention to provide a method of sending a series of ATM cells spread over a plurality of transmission links in a specific round robin order.

It is yet another object of the invention to provide a method of sending ATM cells containing sequence numbers therein over a plurality of transmission links in a specific round robin order.

It is a further object of the invention to provide a method of sending a series of ATM cells between ATM inverse multiplexers over a connection consisting of a plurality of transmission links, transparent to the ATM layer.

5 It is yet another object of the invention to provide a method of sending ATM traffic over a connection which consists of a plurality of transmission links and has been reconfigured after the connection start-up.

10 It is still another object of the invention to provide an ATM inverse multiplexing method which is applicable to UNIs, BICIs and PNNs.

It is a further object of the invention to provide a method of preserving link integrity by periodically sending sequence number cells.

15 It is a further object of the invention to provide a method of handling link failure and link reconfiguration.

Disclosure of the Invention

20 Briefly stated, according to one aspect the invention is directed to a method of sending digital data from a source node to a destination node over a connection consisting of a plurality of transmission links, the digital data containing a series of ATM data cells. The method comprises steps of the source node informing the destination node, at the connection start-up by way of ATM SN cells, of a specific round
25 robin order in which the series of ATM data cells are to be transmitted over the connection, and sending each ATM data cell in the series to the destination node in the round robin order.

30 According to a further aspect of the invention, the method comprises a further step of the source node sending ATM SN cells whose sequence number field is set to indicate the specific round robin order.

According to yet another aspect, the invention comprises repeating the steps which have been performed at the connection start-up, wherever the connection is to be reconfigured.

35 According to still another aspect, the invention comprises a step of a node informing another node of a link failure and repeating the

steps which have been performed at the connection start-up, wherever the connection is to be reconfigured.

Brief Description of the Drawings

5 For a more complete understanding of the invention and for further objects and advantages thereof, reference may now be made to the following description, taken in conjunction with the accompanying drawings, in which:

Figure 1 shows a sample configuration involving AIM UNIs;

10 Figure 2 shows a sample configuration involving AIM BICIs or PNNIs;

Figure 3 depicts the ATM cell structure defined in the ITU Recommendation;

15 Figure 4 is a schematic illustration of multiplexing and demultiplexing of ATM cells over AIMS and links;

Figure 5 shows preassigned cell header values for use by the physical layer;

Figure 6 shows a header pattern of an AIM OAM cell, according to one embodiment of the invention;

20 Figure 7 indicates allocation of OAM functions in the information field according to one embodiment of the invention;

Figure 8 is a schematic illustration of multiplexing and demultiplexing of AIM OAM cells according to one embodiment of the invention; and

25 Figure 9 is a schematic illustration of periodic multiplexing and demultiplexing of AIM OAM cells during transmission of ATM data cells according to one embodiment of the invention.

Mode(s) of Carrying Out the Invention

30 There are requirements that have to be considered when defining a new ATM inverse multiplexing protocol. These requirements are:

- It must multiplex and demultiplex an ATM cell stream distributed in a round robin manner over multiple links such as T1/E1 links.
- 35 • It must adjust up to 32 milliseconds of differential link delays between individual links in a case where T1/E1 links are used.

- It must reconfigure multiple links in the event that a link has to be added, deleted or is considered inadequate to provide service.
- It must be defined for not only UNIs but also for PNNIs and BICIs.
- It must be transparent to the devices handling the convergence of ATM cells into the PDH signal.
- It must be transparent to the devices dealing with ATM layer cells.

The present invention achieves all of the above requirements and solves the problems discussed earlier. The invention relates to a new ATM inverse multiplexing scheme that makes use of a physical layer operation administration and maintenance (OAM) cell which has been properly defined. This OAM cell is defined to contain valuable information to allow proper operation of the ATM inverse multiplexing mechanism and also to provide opportunity for handling a link failure situation.

The newly defined OAM cell is called an AIM OAM cell or AIM Sequence Number (SN) cell and is mainly designed to carry a cell sequence number and a feedback link status field. The sequence number in the SN cell is made available for the receiver end for recovering the initial cell stream from the incoming links. The feedback link status is made available for the receiver to inform the transmitter, by sending its own SN cells, that it is receiving cells and it is also an integral part of the same round robin mechanism, that is to say, the feedback link status value SN cells in either direction must agree with each other, although the sequence numbers at both ends may be different. When the receiver sends its own SN cells in response to the transmitter that it is receiving cells, it is in fact acknowledging that the receiver is ready to receive subsequent ATM data cells.

Figure 4 shows how the ATM cells are multiplexed and then demultiplexed over AIMS in one direction. At the transmitting node, an AIM 10 takes a series of ATM cells from an ATM layer device. It spreads ATM cells and transmits each cell over each of N transmission links, N being a positive integer. The order of transmission is in round robin fashion. This process is called an inverse multiplexing. At the receiving node, cells from N links are inverse demultiplexed (assembled) and sent to an ATM layer device by an AIM 14. The same order must be employed at this node to recover a proper sequence of

cells. Both nodes must be aware of the round robin order which is to be employed. Upon initialization, therefore, both AIMs send a series of SN cells in round robin fashion over the links, e.g. T1/E1 links. This allows the receiver AIM at both nodes to establish the sequence in
5 which to read cells from the incoming links as well as to adjust relative link delay.

As mentioned above, the SN cell also carries an extra field used by each T1/E1 link to indicate that both AIMs belong to the same link round robin. This information can then be used locally to determine if
10 at the corresponding local node a link should be added, removed or maintained in the round robin.

When a change of link configuration occurs by a link being added, removed or declared as being down, each node sends a series of SN cells to allow the far-end node to reestablish the sequence of cells to
15 read from the incoming links.

The protocol of the invention calls for a physical layer OAM cell that is defined to be exclusively processed by the ATM inverse multiplexers. The new cell structure has to be consistent with the cell structure defined in ITU Recommendation I.361. Figure 3 shows that
20 structure of UNI/NNI ATM cells that is defined in I.361. ITU Recommendations I.361 and I.432 state that ATM cells consisting of a header whose VPI and VCI fields are set to zero are reserved for use by the physical layer. So far three preassigned values of the cell header are reserved for use by the physical layer. They are shown in Figure 5.

25 The physical layer OAM cell according to one embodiment of the invention is then defined by using a non-assigned value by setting the PT field to "111". This is shown in Figure 6.

The AIM OAM cell payload is then available for exchanging information between AIMs. The cell payload consists of a series of
30 fields whose locations are shown in Figure 7.

The following fields are identified for the AIM protocol according to one embodiment of the invention:

- ATM inverse multiplexing remote defect indicator (AIMRDI) – one octet is allocated and the proposed coding is all "1".
- 35 • ATM inverse multiplexing far-end receiver ready (AIMFERR) – one octet is allocated and the proposed coding is all "1".

- ATM inverse multiplexing cell sequence number (AIMCSN) – it is defined to contain the sequence number of the cells sent over the multiple links handled by the ATM inverse multiplexers. It is designed so as to have a sufficiently large cycle to allow the ATM inverse multiplexer to absorb link delays of up to 32 milliseconds. There are 16 bits allocated to the AIMCSN field. The counting is then done modulo 65536.
- Cell error control (CEC) – is used to detect errors in the cell payload. It is proposed to CRC-10 as proposed in ITU Recommendation I.432.
- Reserve field (R) – contains the octet pattern of "01101010", which is the same as that of the idle cell as proposed in ITU Recommendation I.361.

Referring to Figure 8, the ATM inverse multiplexing protocol according to one embodiment is described in detail below. The figure only shows one direction for clarity. It is shown that transmission links are all T1/E1 links but, of course, links can have a different speed from T1/E1, as long as all the links have the same speed. A transmitting node 20 collects digital data consisting of a series of ATM data cells from the ATM layer. An ATM inverse multiplexer (AIM) at the transmitting node spreads over multiple links 24 for transmission to a receiving node 26. An AIM at the receiving node reassembles ATM data cells received from the links in proper order and sends them to the ATM layer.

25 Link Start-up

Upon connection start-up, AIMS at both nodes start inserting AIM OAM cells (AIM SN cells) carrying cell sequence number over the available links in round robin fashion. The sequencing of cells is based on the order in which cells have to be transmitted on the virtual link (composed of N physical links). However, the sequence number is only carried over the SN cells. This sequence number assignment allows the receiving AIM to retrieve the original cell sequence. The receiving node queues the received AIM SN cells until it determines the sequence in which to read the ATM data cells from the incoming links as well as the differential delay among individual links. Then, it starts sending AIM SN cells of its own, with the AIMFERR field set to "one" for each link which is now considered "ready" to receive ATM

traffic. From that moment, the receiving node knows the sequence of cells coming from the links. A link is being considered available if cells are currently delineated and AIM-RDI is not received on the incoming link.

5 When the transmitting node starts sending the AIM SN cells, it starts a time-out of 100 milliseconds within which the receiving node determines the sequence of AIM SN cells which it is receiving from the links. The time-out expires unless the transmitting node receives the "ready" signal from all the links which were considered available at the
10 initialization.

 If there is no "ready" link when the time-out expires, the local node reevaluates the availability of the links (using cell delineation), starts sending AIM SN cells over the available links and re-starts the time-out. This procedure is repeated until at least one available link is
15 declared ready.

 When the time-out has been canceled due to the reception of the "ready" signal from all the available links, or when there is at least one link ready when the time-out expires, the local end starts sending ATM layer cells over the "ready" link or links using the same round robin
20 order used at the time of initialization.

 Each ATM layer cell gets a sequence number assigned to it, but only the AIM SN cells carry that number across the links. After both nodes have started sending ATM layer cells, they periodically send a series of "n" AIM SN cells over links to allow the receiving node to
25 readjust the differential delays among the links. The value of "n" is equal to the number of "ready" links used to carry ATM layer cells. This means that the receiving node always scans for AIM SN cells in order to determine if it is always reading cells from the multiple links in the correct order. How often a burst of "n" AIM SN cells is sent
30 depends upon the link utilization but the maximum period has been set to 50 milliseconds in one embodiment. An example of cells sent over a virtual link composed of a plurality of transmission links is shown in Figure 9.

35 Link Reconfiguration

 As mentioned above, the protocol according to the invention

also deals with link reconfiguration. There are three possible cases in which reconfiguration can occur:

- a new link has to be added to the round robin;
- a link has to be intentionally removed from the round robin; and
- 5 • a link has been declared inadequate to provide service (e.g. link down by failure etc.).

In the first two cases, a node starts link reconfiguration by performing the same initialization process for a connection start-up, that is to say, it chooses a round robin order among the links and starts
10 sending AIM SN cells using the chosen round robin order. The receiving node, seeing the occurrence of AIM SN cells, will stop transmitting traffic and starts sending AIM SN cells of its own while adjusting itself to receive traffic from the incoming links. The rest of the protocol is as described earlier for start-up.

15 Two possible cases for reporting failure conditions are:

1) A medium problem reported through Loss of Delineation (LCD) failure condition. In this case, the corresponding link should not be used for service. When detecting LCD, SN cells with AIMRDI set to "1" should be sent over the corresponding outgoing link. SN cells
20 containing AIM-RDI do not carry a valid sequence number. At the far-end, the detection of AIM-RDI signals will indicate that the link is not to be used. Therefore, if LCD or AIM-RDI is detected, the link is no longer considered available and won't be allowed to be part of the round robin on both sides. When this has happens, SN cells are re-
25 sent over the remaining links to re-establish the connection between the two ends.

2) Cells are lost without an LCD or AIM-RDI being reported. For instance, this would occur when a few cells are discarded by the physical layer device due to bit errors in cell headers. This would cause
30 the cell sequencing to be affected. One symptom would be the detection of SN cells whose number is no longer the same as that expected (since one or more of the previous cells are missing). In this case, the problem might be partially corrected by re-adjusting the receiver buffering system (assuming the difference between the SN cell number and the expected number is small). The other symptom would be the
35 absence of a SN cell on one link when getting a burst of SN cells on all the other links. In that case, the local end would have to force the links

to be re-configured. If the symptoms described above reoccur over a given period, the bad link may have to be removed from the round robin.

5 A link reconfiguration also occurs when it takes too much time for one link to receive cells from the far-end (receiving) node, that is to say, no cells within, e.g., 32 milliseconds.

Cell Sequence Number Range

10 Because an ATM inverse multiplexer must absorb a differential delay between individual links of up to 32 milliseconds in one embodiment, and because the system needs to deal with a maximum of 8 T1/E1 links, it is necessary to have a sequence number whose modulo is large enough to accommodate such delay.

15 As a practical example, the following parameters for E1 are considered:

- full rates: 2.048 Mbit/s
- payload rates: $30/32 * 2.048 \text{ Mbit/s} = 1.92 \text{ Mbps}$
- ATM cell: 53 bytes
- ATM cell period time: 221 microseconds
- 20 • ATM cells/32 milliseconds = 144 cells.

For a delay of up to 32 milliseconds on each link, there is a need to queue cells for at least the same length of time on each link. Therefore, in this example, this means that a delay of up to a period of 144 cells between two links is possible. An ATM inverse multiplexer
25 can handle a maximum of 8 T1/E1 links. Therefore up to 1008 cells (144*7 cells) must be queued at one time by one ATM inverse multiplexer. This requires a sequence number modulo large enough to cover this scenario. A simple case in one embodiment is to use a 16-bit count that has modulo 65536.

30 The ATM inverse multiplexing protocol according to the invention realizes the following characteristics:

- it is applicable to UNIs, BICIs and PNNIs (any applicable points in an ATM network);
- it does not affect the ATM cell header of currently defined cells;
- 35 • it does not require a change to current ATM physical layer devices dealing with the convergence of ATM cells into T1/E1;
- it operates transparently to the ATM layer;

- it does not require a change to current devices dealing with the processing of the ATM layer cell;
 - it is self-configuring among available links upon start-up and self-reconfiguring among the multiple links in the case when a new link has to be added, deleted or considered inadequate to provide service; and
 - it includes a sequence number whose modulo is large enough to meet the requirement of a large differential delay among the links.
- 5

WHAT IS CLAIMED IS:

1. In a method of sending digital data from a source node to a destination node over a connection consisting of a plurality of transmission links, said data containing a series of ATM data cells, the invention being characterized in steps of:
- 5 at the connection start-up, the source node sending to the destination node ATM SN cells informing the latter of a specific order in which the series of ATM data cells are to be transmitted over the connection;
- 10 the destination node sending ATM SN cells whose receive ready field is set to indicate that the destination node is ready to receive ATM data cells in specific round robin order from the plurality of transmission links; and
- 15 the source node sending each ATM data cell in said series to the destination node in said round robin order.
2. The method according to claim 1 wherein the step of the source node informing the destination node includes a step of the source node sending a series of ATM SN cells whose sequence number field is set in a sequential order, each ATM SN cell being sent over each transmission link in a specific round robin order.
- 20 3. The method according to claim 2 wherein the step of the destination node sending the source node includes a step of the destination node sending a series of ATM SN cells whose receive ready field is set and whose sequence number field is set in a sequential order, each ATM SN cell being sent over each transmission link in a specific round robin order.
- 25 4. The method according to claim 3 comprising a further step of the source node and destination node sending periodically to one another a series of ATM SN cells over the transmission links in specific round robin order within a predefined time period.
- 30 35

5. The method according to claim 4 wherein said ATM SN cells are physical layer OAM cells whose protocol fields are properly set to indicate types of cells and said sequential order.

5 6. The method according to claim 5 wherein said ATM SN cells are physical layer OAM cells whose protocol fields contain a field to indicate the destination node is ready to receive ATM data cells.

10 7. The method according to claim 4 wherein the source node and destination node send periodically a burst of "n" SN cells to each other over "n" transmission links, within a predetermined maximum time period.

15 8. The method according to claim 7 wherein the period of the source node and destination node sending a burst of "n" SN cells to each other over "n" transmission links is adjustable within the maximum time period, depending upon the link utilization.

20 9. In a method of sending digital data from a node to another node over a connection consisting of a plurality of transmission links, said data containing a series of ATM data cells, the invention being characterized in steps of:

25 whenever the connection is to be reconfigured, a first node sending to the other node ATM SN cells whose sequence number field is set to indicate a specific round robin order in which the series of ATM data cells are to be transmitted over the connection;

30 the other node, in response to the first node, sending ATM SN cells whose receive ready field is set to indicate the other node is ready to receive ATM data cells in specific round robin order from the plurality of transmission links; and

 the first node sending each ATM data cell in said series to the other node in said round robin order.

35 10. A method according to claim 9 comprising further steps of: whenever the connection is to be reconfigured upon failure of a transmission link, a node sending to the other node an indication that a link has failed; and

the two nodes performing the steps recited in claim 9 over the remaining transmission links.

5 11. The method according to claim 9 wherein said ATM SN cells are physical layer OAM cells whose protocol fields are properly set to indicate types of cells and said sequential order.

10 12. The method according to claim 10 wherein said ATM SN cells are physical layer OAM cells whose protocol fields are properly set to indicate the link failure.

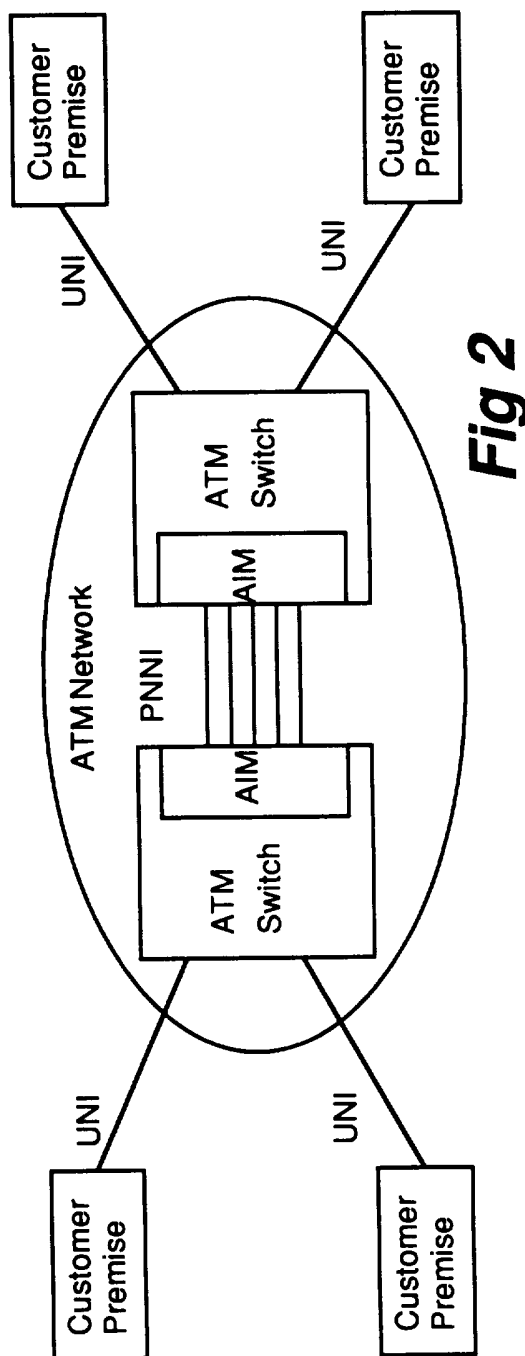
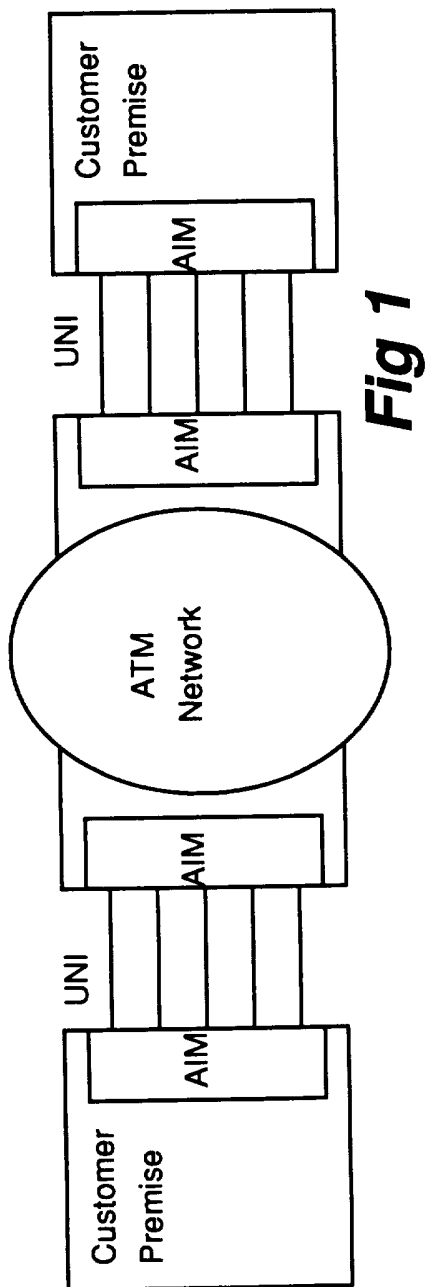

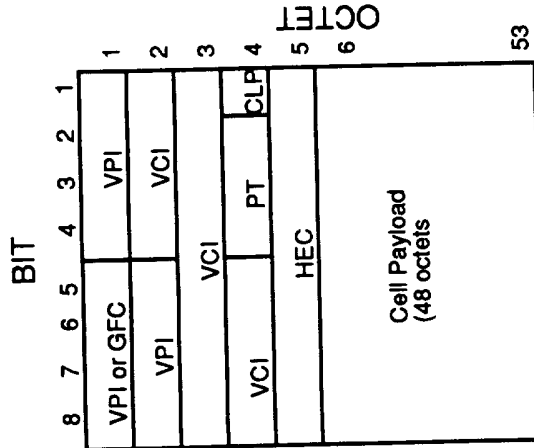

GFC: General Flow Control
 VPI: Virtual Path Identifier
 VCI: Virtual Channel Identifier
 PT: Payload Type
 CLP: Cell Loss Priority
 HEC: Header Error Check

Fig 3

Cell Purpose	Octet 1	Octet 2	Octet 3	Octet 4	Octet 5
Idle cell identification	00000000	00000000	00000000	00000001	01010010
Cell-based interface F1 OAM cell	00000000	00000000	00000000	00000011	01011100
Cell-based interface F3 OAM cell	00000000	00000000	00000000	00001001	01101000

Fig 5

Octet 1	Octet 2	Octet 3	Octet 4	Octet 5 (HEC)
00000000	00000000	00000000	00001111	11001011

Fig 6

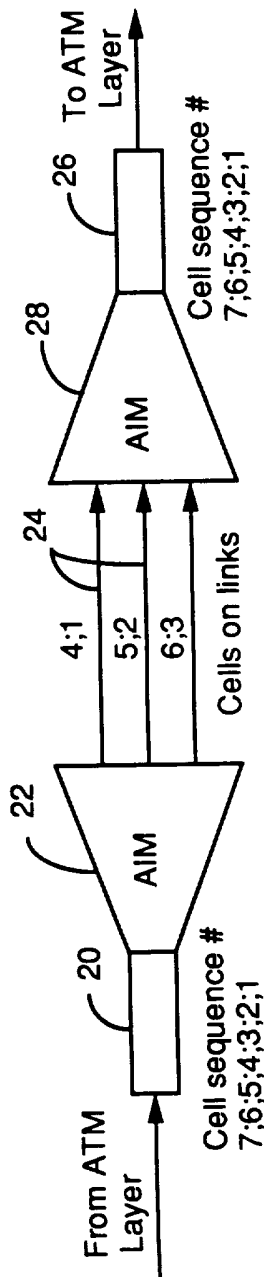
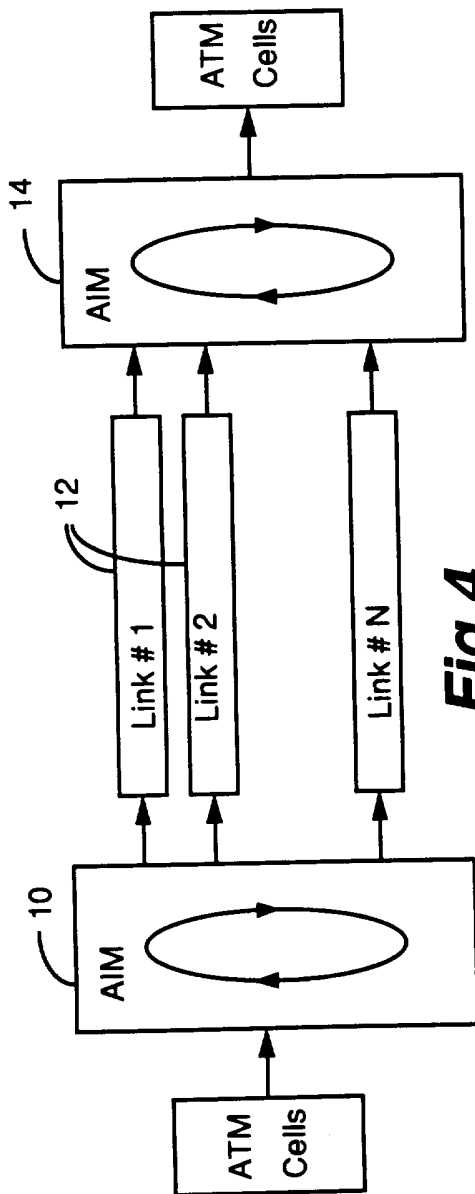

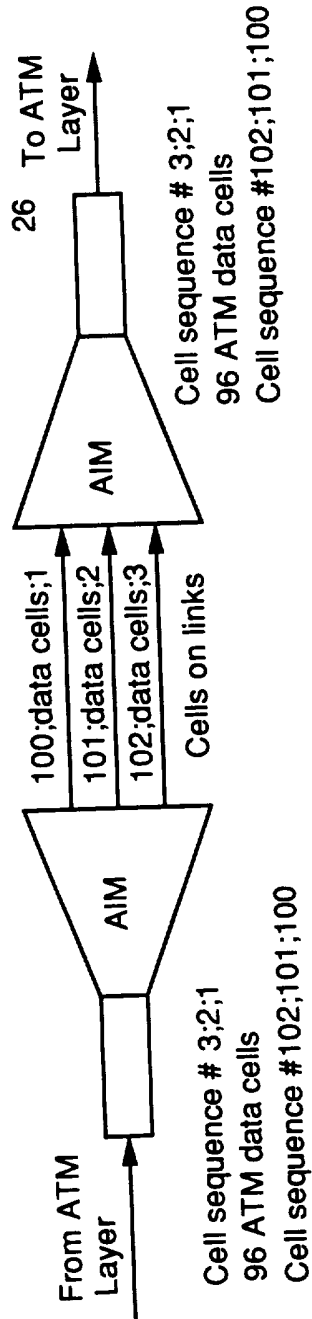

Fig 9

INTERNATIONAL SEARCH REPORT

International Application No
PCT/CA 95/00322

A. CLASSIFICATION OF SUBJECT MATTER
IPC 6 H04Q11/04

According to International Patent Classification (IPC) or to both national classification and IPC

B. FIELDS SEARCHED

Minimum documentation searched (classification system followed by classification symbols)
IPC 6 H04Q H04L

Documentation searched other than minimum documentation to the extent that such documents are included in the fields searched

Electronic data base consulted during the international search (name of data base and, where practical, search terms used)

C. DOCUMENTS CONSIDERED TO BE RELEVANT

Category*	Citation of document, with indication, where appropriate, of the relevant passages	Relevant to claim No.
Y A	WO-A-93 03568 (BRITISH TELECOMMUNICATIONS PLC.) 18 February 1993 see page 2, line 13 - line 27; claims 1,2 ---	1,2 3-12
Y A	WO-A-90 12467 (KJOEBENHAVNS TELEFON AKTIESELS) 18 October 1990 /* abstract */ see claims 1,2; figure 1 ---	1,2 3-12
A	WO-A-94 03005 (SIEMENS AG ;BRUECKNER ROLAND (DE)) 3 February 1994 see claim 1 -----	1-12

Further documents are listed in the continuation of box C.

Patent family members are listed in annex.

* Special categories of cited documents :

- *A* document defining the general state of the art which is not considered to be of particular relevance
- *E* earlier document but published on or after the international filing date
- *L* document which may throw doubts on priority claim(s) or which is cited to establish the publication date of another citation or other special reason (as specified)
- *O* document referring to an oral disclosure, use, exhibition or other means
- *P* document published prior to the international filing date but later than the priority date claimed

- *T* later document published after the international filing date or priority date and not in conflict with the application but cited to understand the principle or theory underlying the invention
- *X* document of particular relevance; the claimed invention cannot be considered novel or cannot be considered to involve an inventive step when the document is taken alone
- *Y* document of particular relevance; the claimed invention cannot be considered to involve an inventive step when the document is combined with one or more other such documents, such combination being obvious to a person skilled in the art.
- *&* document member of the same patent family

Date of the actual completion of the international search

12 September 1995

Date of mailing of the international search report

06. 10. 95

Name and mailing address of the ISA
European Patent Office, P.B. 5818 Patentlaan 2
NL - 2280 HV Rijswijk
Tel. (+ 31-70) 340-2040, Tx. 31 651 epo nl,
Fax: (+ 31-70) 340-3016

Authorized officer

Veen, G

INTERNATIONAL SEARCH REPORT

Information on patent family members

International Application No

PCT/CA 95/00322

Patent document cited in search report	Publication date	Patent family member(s)	Publication date
WO-A-9303568	18-02-93	AU-B- 650780	30-06-94
		AU-A- 2419792	02-03-93
		EP-A- 0598007	25-05-94
		JP-T- 6510405	17-11-94
		US-A- 5414698	09-05-95

WO-A-9012467	18-10-90	AU-A- 5440290	05-11-90
		EP-A- 0466785	22-01-92

WO-A-9403005	03-02-94	CA-A- 2140533	03-02-94
		EP-A- 0651927	10-05-95
