

Feb. 2, 1937.

D. MAPES

2,069,709

HOLDER FOR PRESSURE MEDIUM CONTAINERS OR CARTRIDGES

Filed Oct. 17, 1934

2 Sheets-Sheet 1

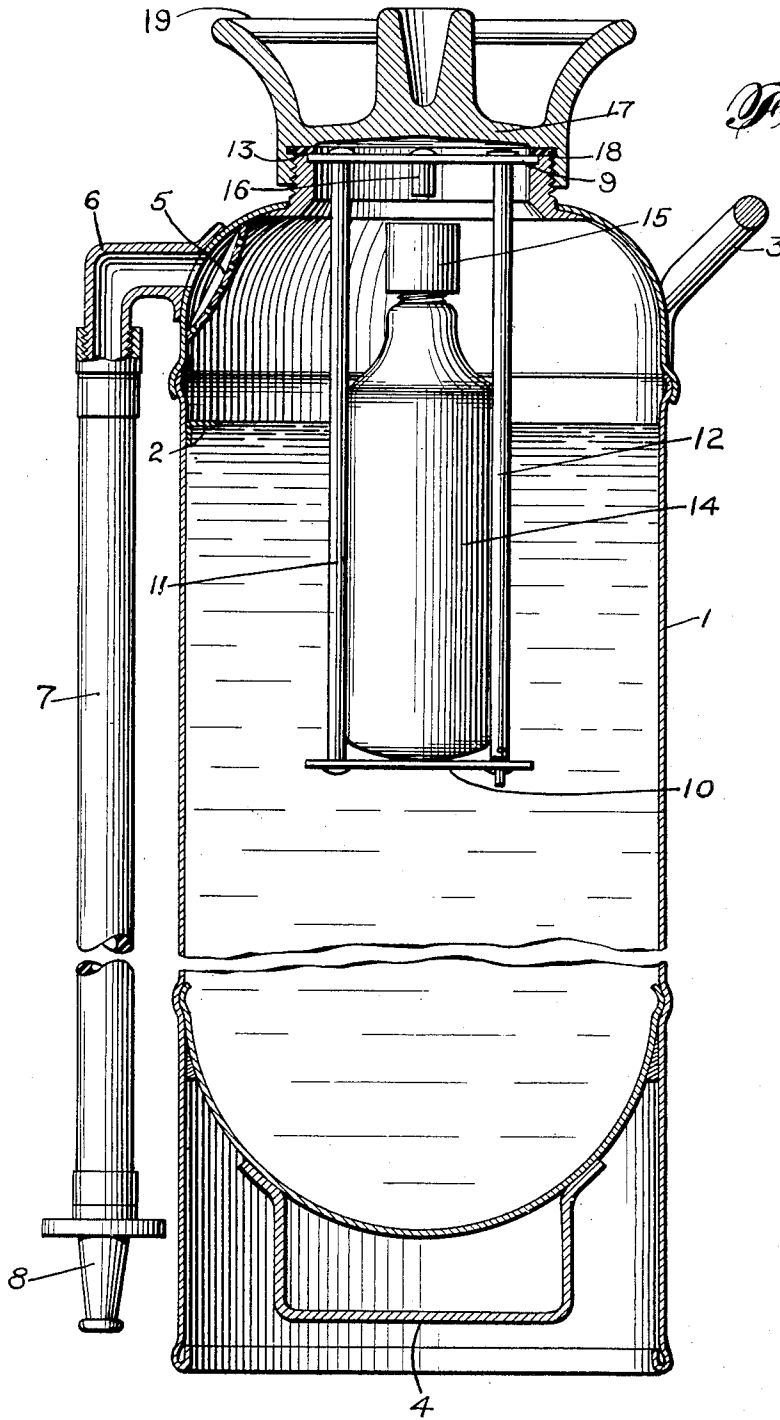

INVENTOR
DANIEL MAPES
BY *Paul G. Anderson*
ATTORNEY

Feb. 2, 1937.

D. MAPES

2,069,709

HOLDER FOR PRESSURE MEDIUM CONTAINERS OR CARTRIDGES

Filed Oct. 17, 1934

2 Sheets-Sheet 2

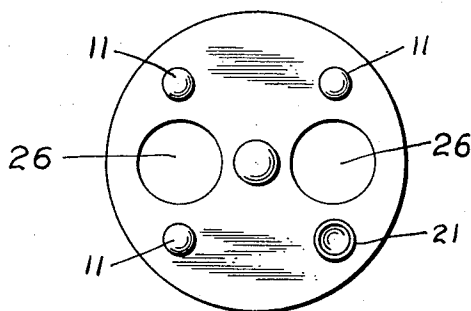

Fig. 3.

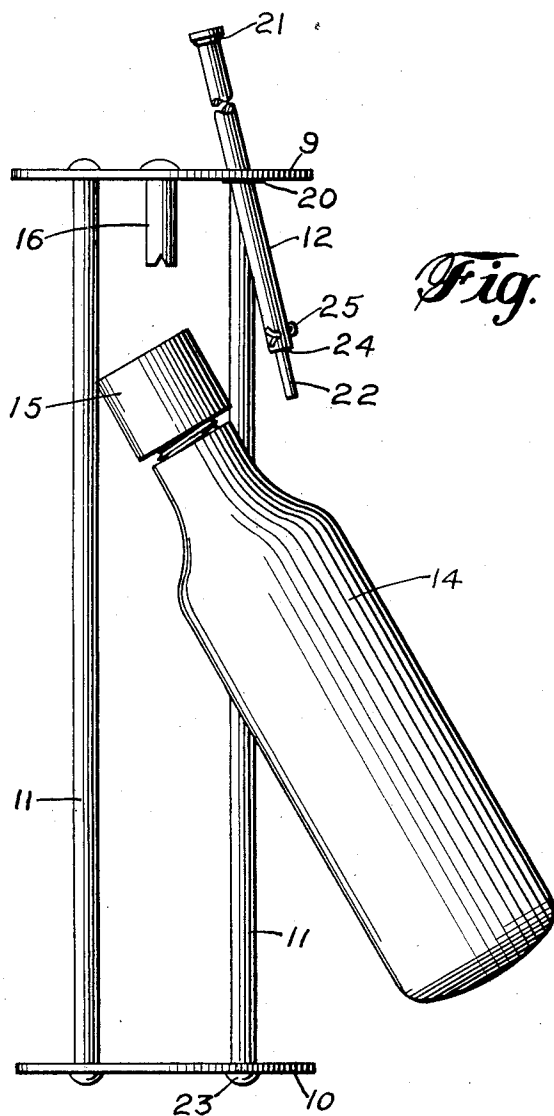

Fig. 2.

INVENTOR
DANIEL MAPES
BY *Paul Anderson*
ATTORNEY

UNITED STATES PATENT OFFICE

2,069,709

HOLDER FOR PRESSURE MEDIUM CONTAINERS OR CARTRIDGES

Daniel Mapes, Montclair, N. J., assignor to Walter Kidde & Company, Inc., Bloomfield, N. J., a corporation of New York

Application October 17, 1934, Serial No. 748,608

2 Claims. (Cl. 169-31)

The present invention relates to fire extinguishing apparatus of the type employing a fire extinguishing liquid propelled by a medium stored under pressure in a cartridge or other container and embodies specifically means for holding or suspending the cartridge in the fire extinguishing apparatus.

More specifically, the present invention relates to a fire extinguisher comprising a container for a fire extinguishing liquid, a cartridge containing gas under pressure, and a holder for the cartridge, the holder supporting the cartridge within the container of fire extinguishing liquid in such a manner that the medium in the cartridge may be easily released.

It is the usual practice to charge the cartridge with a medium under pressure, such as carbon dioxide, the pressure medium being sealed in the container by means which must be punctured in order to release the gas under pressure.

A cartridge, sealing means and seal puncturing device, or preferred embodiments thereof, such as are shown and described in my United States Letters Patent No. 1,919,149, granted July 18, 1933, may be employed.

The difficulty has heretofore been encountered that means for holding the cartridge have been complex and difficult to employ. The present invention therefore broadly contemplates the provision of means for placing a cartridge in the container to form a compact unit that may be easily inserted or removed from the fire extinguishing liquid container.

More specifically the invention contemplates a holder which is supported on the neck of the container of fire extinguishing liquid and within said container.

A desirable advantage of the present invention is that no tools are necessary in order to either insert the cartridge in or remove it from the holder.

An additional advantage of the present invention is that the cartridge can not be removed from nor can it fall out of the holder once it has been placed in the extinguisher container and the cap has been securely fastened to the shell.

A further desirable advantage, is that the holder is so designed that it may be employed in puncturing the sealing means of the pressure medium cartridge.

In extinguishers of the type here contemplated employing a stored pressure medium cartridge, which is certain in operation and capable of widespread adaptation to use with fire extinguishing apparatus of various manufacturers, which can

be sold as a unit for recharging purposes, which is easily replaced and which is in general fool-proof, it is necessary that a holder which will receive a cartridge easily and yet hold it securely, be provided. With the holder of the present invention, other types of extinguishers such as soda and acid fire extinguishers, may easily be converted into stored pressure medium propelled liquid extinguishers.

The invention will now be described in detail with reference to the accompanying drawings, wherein:

Figure 1 is a central longitudinal view of an extinguisher embodying the invention.

Figure 2 is a longitudinal view of a holder according to the present invention.

Figure 3 is a top view of a holder or cage in accordance with the present invention.

In Figure 1 of the drawings there is represented at 1 a standard shell or container for holding a liquid fire extinguisher medium, such as water, calcium chloride solution, or other suitable fire extinguishing medium, which is filled into the container up to the level of the filling indicator 2. The shell is provided with a handle 3 for carrying the extinguisher in an erect position, another handle 4 for carrying the extinguisher in an inverted position, a strainer 5, an outlet elbow 6, and a standard hose 7 coupled to the outlet elbow and having a discharge nozzle 8. A holder or cage comprising an upper flange 9, a base plate 10 and suspension rods 11 and 12 is supported upon a shoulder 13 in the neck of the shell and in turn supports a cartridge 14 containing a medium under pressure, such as liquid carbon dioxide, for propelling the liquid fire extinguishing medium from the shell. The cartridge 14 is provided with a coupling 15 containing means for effecting release of the pressure medium from the cartridge, for example, such as is more fully described in my United States Letters Patent No. 1,919,149, said releasing means becoming operative upon inversion and jarring of the shell, whereby to cause forcible engagement of the releasing means with a projection 16 formed on the top flange 9. A cap 17 is threaded to the neck of the shell with an intervening gasket 18, which not only effects a leakage-tight joint with the shell, but secures the flange 9 of the cage against movement. The cap 17 is otherwise standard, being provided with a rim handle 19 for carrying the extinguisher in an upright position and for effecting rotation of the cap.

The holder which will now be described in further detail in connection with Figures 2 and 3, 55

comprises three suspension rods 11, which are securely fastened at one end to the upper flange 9 and at the opposite end to the base plate 10. These rods are so spaced that the distance between any two of them on the same edge of the base is always less than the diameter of the cartridge 14. This distance is chosen to prevent the cartridge from passing between them and to thereby retain it in the holder. A fourth suspension rod 12 is provided, which slides in a hole 20 in the flange 9. The rod 12 has an enlarged head 21 at the end situated above the flange 9, the head being of a greater diameter than the hole 20 of the flange 9, so that the head cannot pass through the hole in the flange. The opposite end of the rod is provided with a shank 22 of a smaller diameter than the rod, the shank being of such a size that it will readily slide into a hole 23 in the base 10 and permit the shoulder 24 to rest on the base 10. Of course, in practice, the rod 12 might be so made that it will rest on the head 21, or on the shoulder 24 and the head 21 at the same time. When the cage is being assembled, the shank 22 is first pushed through the hole 20 in the upper flange 9. A means of preventing the rod 12 from slipping out of the flange 9 after assembly, such as a cotter pin 25, is also provided. The rods 11 and 12 are so proportioned that when a cartridge has been inserted in the holder and is resting on the base 10, as shown in Figure 1, the projection 16 is spaced a desired distance from the releasing means in the coupling 15.

It will be readily apparent that when it is desired to either insert or remove a cartridge, it is only necessary to raise the rod 12 and place the cartridge on the base 10, as illustrated in Figure 2. The rod 12 is then dropped in position through the hole 23 in the base 10 and the cartridge is then prevented from falling out of the holder by the suspension rods.

When the cage and cartridge have been placed in the extinguisher and the cap 17 has been securely tightened to the shell 1, the rod 12 cannot fall out upon inversion of the extinguisher, since the clearance space between the flange 9 and the cap 17 is not so great as to permit the shank 22 of the pin 12 to come out of the hole 23 in the base 10.

In Figure 3 is shown a view of the top flange 9, wherein is illustrated finger holes 26, which facilitate the removal of the cage from the liquid container.

The projection 16, which is securely fastened to the flange 9, serves the purpose of releasing the pressure medium from the cartridge when the extinguisher, normally in an erect position as shown in Figure 1, is inverted, causing the cartridge to fall. The cartridge and pin are so spaced that the projection 16 enters into the coupling 15 and operates the releasing means, which permits the escape of the stored pressure medium.

In view of the present invention the act of recharging an extinguisher is exceedingly simple, comprising removing the cap 17 from the shell 1, removing the holder and cartridge 14, substituting a new cartridge in the holder, filling the

shell with liquid fire extinguishing medium up to the level of the filling indicator 2, and replacing the cap 17.

From the foregoing description it will be seen that I have made new and useful improvements in cages for holding or suspending stored pressure medium cartridges for use with pressure propelled liquid fire extinguishing mediums. While the invention has been described with specific reference to the accompanying drawings, it is not to be limited, save as defined in the appended claims.

I claim:

1. A unitary holder and releasing means for a stored pressure medium cartridge adapted to permit the cartridge to move by the force of gravity upon inversion thereof from a normal position comprising a supporting flange, finger holes in said flange, a plurality of rods rigidly fastened at one end to said flange, a base rigidly fastened at the opposite end of said rods, a movable rod associated with both said flange and said base, said movable rod having a head adapted to rest on said flange to hold the rod in position by its own weight when the holder is in its normal position, a stop on said movable rod to prevent withdrawal of the rod from the flange, said stop being so positioned that the rod may be moved to permit the cartridge to be inserted in and removed from the holder, and a projection on said flange adapted to forcibly engage said cartridge upon movement of the cartridge by the force of gravity when the holder is inverted, whereby to effect release of the pressure medium from the cartridge.

2. In a fire extinguishing apparatus, a container for a fire extinguishing medium having a filling opening at one end thereof, a removable cap for said opening, a cartridge containing a pressure medium for expelling the fire extinguishing medium from said container, a holder for said cartridge adapted to permit the cartridge to move by the force of gravity upon inversion thereof from a normal position comprising a flange, finger holes in said flange, a plurality of rods fastened at one end to said flange, a base fastened to the opposite end of said rods, a movable rod passing through both said flange and said base, said movable rod having a head adapted to rest on said flange plate to hold the rod in position by its own weight when the holder is in its normal position, a stop on said movable rod to prevent withdrawal of the rod from the flange, said stop being so positioned that the rod may be moved to permit the cartridge to be inserted in and removed from the holder, and a projection on said flange adapted to forcibly engage said cartridge upon movement of the cartridge by the force of gravity when the holder is inverted, whereby to effect release of the pressure medium from the cartridge into the outer container, the arrangement being such that said cap serves both to retain the holder within the outer container and to prevent removal of the cartridge from the holder by engaging the head on said movable rod.

DANIEL MAPES.