

Nov. 24, 1931.

R. F. NORRIS

1,833,174

FURRING STRIP

Original Filed Aug. 11, 1927

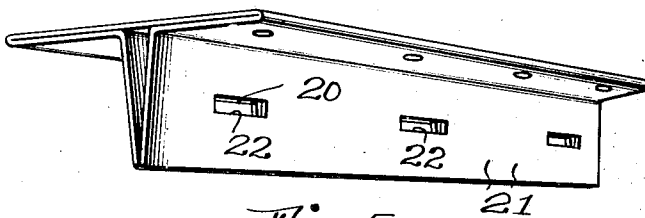
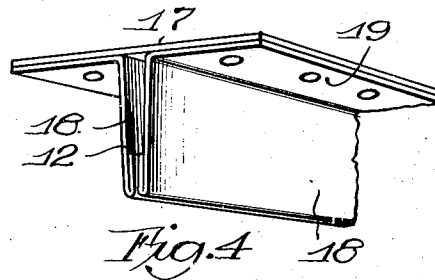
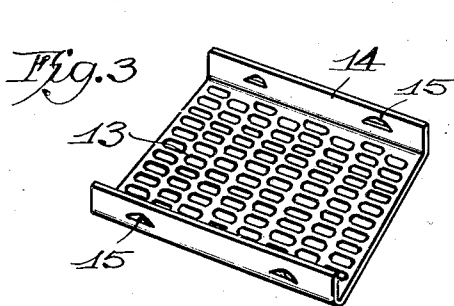
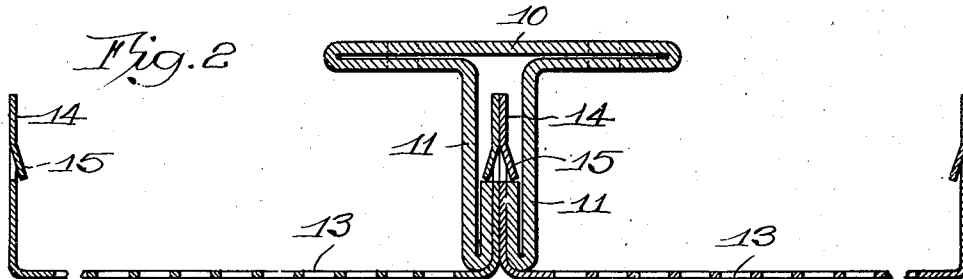
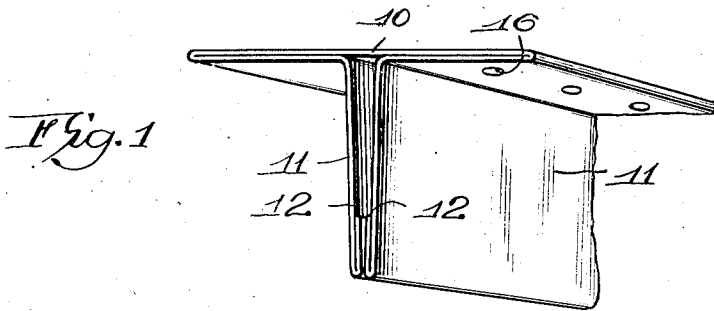

Witness:  
Chas. P. Kousch

Inventor,  
Ralph Forbush Norris  
George Bayard Jones, Atty

# UNITED STATES PATENT OFFICE

RALPH FORBUSH NORRIS, OF MADISON, WISCONSIN, ASSIGNOR TO C. F. BURGESS LABORATORIES, INC., OF MADISON, WISCONSIN, A CORPORATION OF DELAWARE

## FURRING STRIP

Original application filed August 11, 1927, Serial No. 212,265. Divided and this application filed January 25, 1928. Serial No. 249,453.

This invention relates to improvements in furring strips and the like, adapted particularly for use in sound deadening constructions. The invention is disclosed in my abandoned application, filed August 11, 1927, Serial No. 212,265 of which the present application is a division and is also disclosed in my Patent No. 1,726,500, issued August 27, 1929, filed February 25, 1929.

The principal object of the invention is to provide an improved furring strip of economical construction which is adapted to engage and support the metal sheets or tile which carry the sound deadening material, the furring strips being concealed by the tile in the completed installation.

A further object of the invention is to provide furring strips along certain forms of which the tile may be moved to or from a given position whereby all of the tiles can be removed without mutilation, other than possibly one or two tiles of each row or tier.

Other objects relate to various features of construction of the furring strips, as will become apparent from a consideration of the following specification and drawings, wherein:

Fig. 1 is a perspective view of a form of the improved furring strip formed of a single piece of sheet metal,

Fig. 2 is a view showing the manner in which a strip engages and supports the contiguous foraminous tiles which support the sound deadening material (not shown),

Fig. 3 is a perspective view of a suitable form of tile,

Fig. 4 shows a modified form of furring strip in which the legs are formed of strips of metal separate from the back or base member, and

Fig. 5 illustrates an additional modification of the invention.

In Figs. 1 and 2 of the drawings, the furring strip is shown formed of a single piece of sheet metal having a back or base portion 10, the sheet material being folded back substantially parallel to itself and preferably, although not necessarily, almost into contact with the under face of the base, then as best shown in the sectional view, Fig. 2. The metal

is also bent in a direction nearly at right angles to said base to form the legs 11, thus giving the strip a T shape in cross section. The legs 11 preferably converge as shown in Fig. 1, the free edge or end of the leg material, in each case, being folded inwardly i. e. upwardly in the position shown, to form longitudinal ledges or supports 12 for supporting the tiles 13, illustrated in Fig. 3. These tiles may be of sheet metal having flanges 14 which are provided with ears 15 and are adapted for engagement with the ledges 12 as shown clearly in Fig. 2. The material of the furring strip is resilient, whereby the legs can be sprung apart sufficiently to permit the insertion of the flanges 14 of the tile 13 and thus effect the inter-locking with the ledge 12 of the ears 15, as will be apparent. Although the upwardly bent edges of the legs are shown folded back fairly close to the legs themselves, with only a small clearance between these resilient members, it is evident that the extent to which said parts are bent is not especially important as long as they are bent back far enough to insure a positive locking engagement between said edges and said ears. Also a smooth bend at the lower end is preferred, to provide a flaring or tapering inlet at the lower end of the furring strip to facilitate the insertion of said legs 14. Openings 16 are provided for receiving fastening means such as screws, nails or toggle bolts by means of which the furring strips are secured to the wall or ceiling surfaces.

In Fig. 4 the construction is similar to that shown in Fig. 1, except that the back member 17 is formed of a strip separate from the strip of which the legs 18 are formed. The legs are provided with flanges 19 which are suitably secured to the back 17 by any approved means such as welding, whereby the fabricated strip is made an integral unit.

In Fig. 5 a modified form of the furring strip is shown in which the legs and back are formed of a single piece of resilient sheet material. In this form of the invention, the free edges of the legs are not folded upwardly to form the supporting ledges shown in the other figures, but slots or openings 20 are formed in the legs 21 to provide ledges or

surfaces 22. These ledges 22, like the ledges of the previously described forms of the invention, form horizontal supports for the ears 15 of the tile, permitting inter-locking engagement.

Although I have shown certain features of my improvements for the purpose of illustration, it will be apparent that changes may be made therein without departing from the spirit of the invention as defined in the appended claims.

What I claim is:

1. A furring strip formed of sheet metal comprising a supporting base section and a pair of resilient legs extending therefrom, converging toward their free edges and having means for positively securing and supporting one or more articles inserted therebetween, by a movement toward said base section.

2. A furring strip of sheet metal having a base member adapted to be secured to a support and a pair of resilient legs integral therewith, said legs extending from said base in a direction away from said support and converging toward their free edges and being adapted to be sprung apart for the insertion therebetween of members to be supported thereby, each leg having at least one ledge substantially normal to the plane of the leg for effecting positive engagement with one or more of said members.

3. A furring strip comprising a base adapted to be secured to a support, a pair of legs extending from said base in a direction away from said support, said legs being spaced apart along corresponding edges and bearing against each other along their opposite edges, each leg having means for supporting one of two articles inserted between said legs, said legs being resilient and tending normally to exert spring pressure against said articles to prevent disengagement of the same from the supporting means.

4. A metal furring strip comprising a base section and two resilient leg sections supported thereby, each leg section having a free end folded toward itself to form positive engaging means for articles to be supported by the strip.

5. A metal furring strip comprising a pair of resilient leg sections secured at their upper edges in suitably spaced relation, and converging toward their free edges which are adapted to be sprung apart for inserting therebetween the articles to be supported by the strip, and means disposed between the edges of each leg section for positively securing the articles in position.

6. As an article of manufacture, a composite fabricated sheet metal furring strip T shaped in cross section, said strip being formed of two L shaped sections placed back to back and spaced slightly apart at their bases, the bases of said sections being welded

to a backing strip, the leg of each section being folded inwardly upon itself to form a double portion resiliently bearing against the other double portion.

7. As an article of manufacture a metal furring strip having a lateral portion adapted to be secured to a plane surface and having two independently movable resilient leg members spaced slightly apart with ledge forming means thereon, said ledges forming positive engaging means for articles inserted between said members for resisting stresses exerted on said articles in a direction substantially parallel with the plane of said members.

8. As an article of manufacture, a sheet metal furring strip T shaped in cross section, said strip comprising L shaped sections disposed back to back and spaced slightly apart at their bases, the leg of each section being folded inwardly to form a double portion resiliently bearing against the other double portion.

9. A furring strip comprising a pair of resilient legs each having means comprising ledges for positively engaging one of two articles inserted therebetween in abutting end to end relation, said legs tending to press the articles together and prevent the disengagement thereof from the respective engaging means.

In testimony whereof, I have subscribed my name.

RALPH FORBUSH NORRIS.