



- (51) **International Patent Classification:**
B62D 61/12 (2006.01) *B62D 55/02* (2006.01)
- (21) **International Application Number:**
PCT/SE2016/050569
- (22) **International Filing Date:**
13 June 2016 (13.06.2016)
- (25) **Filing Language:** Swedish
- (26) **Publication Language:** English
- (30) **Priority Data:**
1550970-6 3 July 2015 (03.07.2015) SE
- (71) **Applicant:** KOMATSU FOREST AB [SE/SE]; P.O. Box 7124, 907 04 Umeå (SE).
- (72) **Inventors:** NILSSON, Erik; Byvägen 17C, 913 42 Obbola (SE). BOSTRÖM, Ola; Marinvägen 19, 907 88 Täfteå (SE).
- (74) **Agent:** ZACCO SWEDEN AB; P.O. Box 5581, Valhallavägen 117N, 114 85 Stockholm (SE).
- (81) **Designated States** (unless otherwise indicated, for every kind of national protection available): AE, AG, AL, AM, AO, AT, AU, AZ, BA, BB, BG, BH, BN, BR, BW, BY, BZ, CA, CH, CL, CN, CO, CR, CU, CZ, DE, DK, DM,

DO, DZ, EC, EE, EG, ES, FI, GB, GD, GE, GH, GM, GT, HN, HR, HU, ID, IL, IN, IR, IS, JP, KE, KG, KN, KP, KR, KZ, LA, LC, LK, LR, LS, LU, LY, MA, MD, ME, MG, MK, MN, MW, MX, MY, MZ, NA, NG, NI, NO, NZ, OM, PA, PE, PG, PH, PL, PT, QA, RO, RS, RU, RW, SA, SC, SD, SE, SG, SK, SL, SM, ST, SV, SY, TH, TJ, TM, TN, TR, TT, TZ, UA, UG, US, UZ, VC, VN, ZA, ZM, ZW.

(84) **Designated States** (unless otherwise indicated, for every kind of regional protection available): ARIPO (BW, GH, GM, KE, LR, LS, MW, MZ, NA, RW, SD, SL, ST, SZ, TZ, UG, ZM, ZW), Eurasian (AM, AZ, BY, KG, KZ, RU, TJ, TM), European (AL, AT, BE, BG, CH, CY, CZ, DE, DK, EE, ES, FI, FR, GB, GR, HR, HU, IE, IS, IT, LT, LU, LV, MC, MK, MT, NL, NO, PL, PT, RO, RS, SE, SI, SK, SM, TR), OAPI (BF, BJ, CF, CG, CI, CM, GA, GN, GQ, GW, KM, ML, MR, NE, SN, TD, TG).

Declarations under Rule 4.17:

- as to the identity of the inventor (Rule 4.17(i))
- as to applicant's entitlement to apply for and be granted a patent (Rule 4.17(ii))

Published:

- with international search report (Art. 21(3))

(54) **Title:** ARRANGEMENT AND VEHICLE

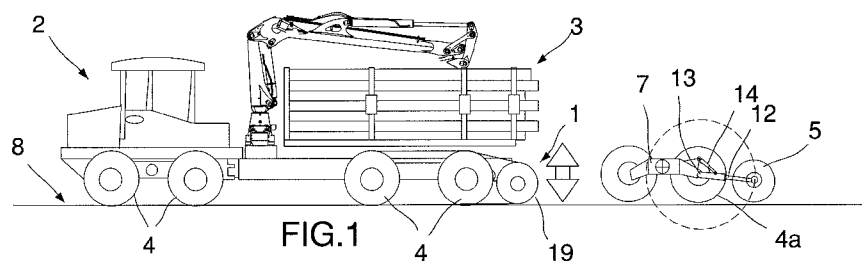

(57) **Abstract:** This invention concerns an arrangement (1) intended to be mounted at a vehicle (2) intended for forestry, comprising a load-bearing part (3) and driving bogie wheels (4) where the arrangement (1) comprises at least two extra wheels (5) that can be individually controlled in the vertical direction where each extra wheel is arranged at a shaft (6) that is fixed and that is not rotatable, pivotable, and is arranged at the bogie box (7) of the vehicle in order to distribute the weight of the machine. The individually controlled extra wheels (5) are subject to a driving force and mounted at at least two arms (12) arranged at the bogie boxes of the vehicle, that a track (18) is placed around each set of bogie wheels (4) and the extra wheel (5) in order to protect against skidding and to distribute the weight, reducing the ground pressure and that a tension arrangement (19) in the form of a cylinder under pressure or a coiled spring unit is arranged at each arm in order to absorb motions in the length of the arm (12) such that the length of the track does not change when the arm (12) moves up and down. The invention concerns also a vehicle (2) comprising such an arrangement (1).

WO 2017/007395 A1

Arrangement and vehicle

TECHNICAL AREA

This invention concerns an arrangement intended to be mounted at a vehicle that comprises a load-
5 bearing part and driving wheels. The invention concerns also a vehicle comprising such an arrangement.

BACKGROUND

Vehicles, machines, agricultural machines and forestry machines have long been used within forestry in order to automate many of the operations that are to be carried out on location in a forest. The
10 vehicles have a weight that is not insignificant, independently of whether they are driven with the aid of wheels or tracks, which means that the forest, the support of the vehicle in the forest, the ground, over which the vehicle is driven and on which it stands, is affected. The ground is compressed by the weight of the vehicle and the damage to the ground may be permanent in the form of damage that does not recover without intervention. This damage to the ground may result in erosion, leakage of
15 humus and nutrients, the unplanned formation of ditches, and compression of the pore system of the ground, all of which may have consequences. All such consequences affect the remaining forest, through, for example, lower resistance to storms due to roots that are torn off and/or thick roots that are shallow, to increased root rot as a consequence of root damage, and to loss of growth. Once the damage has taken place, all attempts to restore the ground are expensive, or totally impossible.

20 Repair of damage caused by driving is most often of a cosmetic nature. Up to half of the support capacity of the ground arises from the roots. The support capacity is, therefore, difficult to restore when the vegetation and root systems have been broken. Furthermore, repair by, for example, the use of an excavator means that the ground is excavated one more time. This increases further the risk for the undesired transport of slurry, humus, nutrients and heavy metals into lakes and watercourses. For
25 these reasons, the damage caused by driving should be attempted to be prevented as far as possible.

In order to avoid damage to the ground and damage caused by driving, a great deal of time has been invested in planning appropriate routes, passages and collection points well in advance of a felling operation. This is not only time-consuming but also expensive.

The compression of the ground by the weight of the vehicle can lead also to the driving of the vehicle becoming more difficult.

SUMMARY OF THE INVENTION

5 One purpose of the present arrangement is to reduce the influence on the forest from a vehicle, on the support of a vehicle in the forest, on the ground, where the vehicle is driven or allowed to stand. This purpose is achieved with an arrangement comprising the technical features that are made clear by claim 1. This purpose is achieved also with a vehicle comprising such an arrangement according to claim 13.

DESCRIPTION OF DRAWINGS

10 Figure 1 shows a vehicle and an arrangement according to the invention.

Figure 2 shows the vehicle and the arrangement in Figure 1 from above.

Figure 3 shows a second embodiment of a vehicle and an arrangement according to the invention.

Figure 4 shows the vehicle and the arrangement in Figure 3 from above.

Figure 5 shows an auxiliary motor comprised in an arrangement according to the invention.

15 Figure 6 shows a damping arrangement comprised in an arrangement according to the invention.

Figure 7 shows a tension arrangement comprised in an arrangement according to the invention.

DESCRIPTION OF EMBODIMENTS

20 This invention concerns an arrangement 1 intended to be mounted at a vehicle 2. The vehicle 2 comprises a load-bearing part 3 and driving bogie wheels 4.

25 The arrangement 1 comprises at least two extra wheels 5 that can be individually controlled, where each extra wheel 5 is arranged at a fixed, non-rotatable, pivotable, shaft 6. At least one bogie wheel 4 is arranged at, fixed at, a bogie box 7. Also the extra wheel 5 is arranged at, fixed at, the bogie box 7 in order to distribute the weight of the machine, the gross weight of the machine including its payload weight, over more areas of a support 8, the ground, and in this way improve the distribution of weight and reduce the pressure against the support, the ground. The extra wheels 5 give a direct support and

a supplementary ability to distribute the weight, in addition to the normal vehicle wheels 4. See Figures 1-4.

5 The term "individually controlled extra wheels 5" is here used to denote that each extra wheel, independently of its location on the vehicle 2, can be controlled and adjusted and can follow the support 8, without being influenced by, and without influencing, other extra wheels and their locations. It is possible also that two extra wheels 5 be located on the same side of the vehicle 2, if this is required in special terrain. It is possible also that more than two extra wheels 5 be mounted at a vehicle.

10 The individually controlled extra wheels 5 are subject to a driving force. The driving force on the wheels further facilitates the driving of the vehicle 2 on the support, and since the extra wheels 5 are driven and move relative to the support, the extra wheels 5 will be in motion and will not become as easily stuck in such material as is located on the support 8, such as, for example, vegetation.

15 The individually controlled extra wheels 5 may be hydraulically driven or electrically driven. It is appropriate that the arrangement 1 comprise an auxiliary motor 9 that drives each extra wheel 5. The motor 9 is driven by a hydraulic system comprising a pump 10. The pump 10 is driven by an additional source of energy 11, such as, for example, a diesel engine, electric motor or similar. See Figure 5.

20 The arrangement 1 comprises at least two arms 12 on which an extra wheel 5 is mounted. Each arm 12 is individually controlled and mounted in bearings, and can move independently of the motion of the other arm. Each arm 12 is principally mounted in bearings in a horizontal axis 13 that essentially coincides with the closest wheel 4a of the bogie and its wheel axle, in order to permit the extra wheel 5 to be lifted up and down without the axle separation between the closest wheel 4a of the bogie and the extra wheel 5 changing by any amount worthy of mention.

25 Each arm 12 comprises a damping arrangement 14 that damps the motions of the arm. It is appropriate that the damping arrangement 14 of the arm comprise a damped cylinder that retains, presses, the extra wheel 5 against the support 8 in order to ensure that the extra wheel 5 is in contact with the support 8 and in this way improve the distribution of weight and reduce the pressure exerted
30 by the vehicle 2 onto the support 8, the ground. The damping arrangement, the damped cylinder 14, is controlled by a hydraulic unit 15 that is fed by a hydraulic pump 16 that obtains its energy from a

selected source of energy 17, such as, for example, an electric motor, a diesel engine or other source of energy or source of driving power. The damping arrangement, the damping cylinder 14, comprises an accumulator 18 that offers a spring facility and that can store energy for a short period. See Figure 6.

- 5 The arrangement 1 comprises a track 19 that protects against skidding, distributes the weight, and reduces ground pressure. This track 19 is located around each set of bogie wheels 4 and the extra wheel 5. See Figures 1 and 3.

Two extra wheels 5 are arranged at at least two bogie boxes 7, one on each bogie box 7, arranged to be parallel one on each side of the vehicle 2, one extra wheel 5 at one of the two bogie wheels 4 in the
10 forwards and/or backwards direction of the vehicle 2 one on each side of the vehicle 2. See Figures 1 and 2. A further alternative is that four extra wheels 5 are arranged at at least two bogie boxes 7 arranged to be parallel one on each side of the vehicle 2, one extra wheel 5 at each bogie wheel 4 in the forwards and backwards direction of the vehicle 2. See Figures 3 and 4.

The arrangement comprises a tension arrangement 19 in the form of a spring-loaded arrangement,
15 such as a cylinder under pressure or a coiled spring unit, in order to absorb motions along the length of the arm 12 such that the length of the track, and its tension, do not change when the arm 12 moves up and down. See Figure 7.

The invention concerns also a vehicle 2 comprising an arrangement 1 of the type that has been
20 described above. The load-bearing part 3 of the vehicle comprises a conventional load-bearing frame. The load-bearing part may comprise also a separate displaceable load carrier. The driving wheels 4 of the vehicle comprise a mechanically driven, a hydraulically driven, or an electrically driven bogie. See Figures 1-7.

25 The vehicle 2 is intended to be used within forestry or agriculture since it is within these fields of use that it is economically and biotopically interesting that damage to the ground is avoided or at least minimised. Other fields of use in which damage to the ground should be avoided or at least minimised may, of course, become relevant.

CLAIMS

1. An arrangement (1) intended to be mounted at a vehicle (2) intended for forestry, comprising a load-bearing part (3) and driving bogie wheels (4) where the arrangement (1) comprises at least two extra wheels (5) that can be individually controlled in the vertical direction where
5 each extra wheel is arranged at a shaft (6) that is fixed and that is not rotatable, pivotable, and is arranged at the bogie box (7) of the vehicle in order to distribute the weight of the machine, the gross weight of the machine including its payload weight, over more areas of a support (8) and in this way improve the distribution of weight and reduce the pressure exerted against the support (8), characterised in that the individually controlled extra wheels (5) are subject to a
10 driving force and mounted at at least two arms (12) arranged at the bogie boxes of the vehicle, that a track (18) is placed around each set of bogie wheels (4) and the extra wheel (5) in order to protect against skidding and to distribute the weight, reducing the ground pressure and that a tension arrangement (19) in the form of a cylinder under pressure or a coiled spring unit is arranged at each arm in order to absorb motions in the length of the arm (12) such that the
15 length of the track does not change when the arm (12) moves up and down.
2. The arrangement according to claim 1, where the individually controlled extra wheels (5) are subject to a driving force.
- 20 3. The arrangement according to claim 2, comprising an auxiliary motor (9) that drives the extra wheel.
4. The arrangement according to claim 3, where the motor (9) is driven by a hydraulic system comprising a pump (10).
- 25 5. The arrangement according to claim 4, where the pump (10) is driven by a further source of energy (11).
6. The arrangement according to claim 1, where each arm (12) is individually controlled and mounted in bearings, and can move independently of the motion of the other arm.

- 5 7. The arrangement according to any one of the preceding claims, where each arm (12) is mounted in bearings in a horizontal axis (13) that essentially coincides with a wheel axle at the wheel at the bogie that is closest to the extra wheel, in order to permit the extra wheel (5) to be lifted up and down without the axle separation between the closest wheel (4a) of the bogie and the extra wheel (5) changing by any amount worthy of mention.
8. The arrangement (1) according to any one of claims 6-7, where each arm (12) comprises a damping arrangement (14) that damps the motions of the arm.
- 10 9. The arrangement (1) according to claim 8, where the damping arrangement (14) comprises a cylinder that damps the motions of the arm and that is controlled by a hydraulic unit (15) that is fed by a hydraulic pump (16) that obtains its energy from a selected source of energy (17).
- 15 10. The arrangement (1) according to claims 8 or 9, comprising an accumulator (18) that offers a spring facility and that can store energy for a short period.
- 20 11. The arrangement according to any one of claims 1-10, where two extra wheels (5) are arranged at at least two bogie boxes (7), arranged to be parallel one on each side of the vehicle (2), one extra wheel (5) at one of the two bogie wheels (4a) in the forwards and/or backwards direction of the vehicle (2), one on each side of the vehicle (2).
- 25 12. The arrangement according to any one of claims 1-11, where four extra wheels (5) are arranged at at least two bogie boxes (7), arranged to be parallel on each side of the vehicle (2), one extra wheel (5) at each bogie wheel (4a) in the forwards and backwards direction of the vehicle (2).

13. A vehicle (2) comprising an arrangement (1) according to any one of claims 1-12.

14. The vehicle (2) according to claim 13, where the load-bearing part (3) comprises a conventional load-bearing frame.

5

15. The vehicle (2) according to claim 13 or 14, where the load-bearing part (3) comprises a separate displaceable load carrier.

10

16. The vehicle (2) according to any one of claims 13-15, where the driving bogie wheels (4) comprise a mechanically driven bogie.

17. The vehicle (2) according to any one of claims 13-15, where the driving bogie wheels (4) comprise a hydraulically driven bogie.

15

18. The vehicle (2) according to any one of claims 13-15, where the driving bogie wheels (4) comprise an electrically driven bogie.

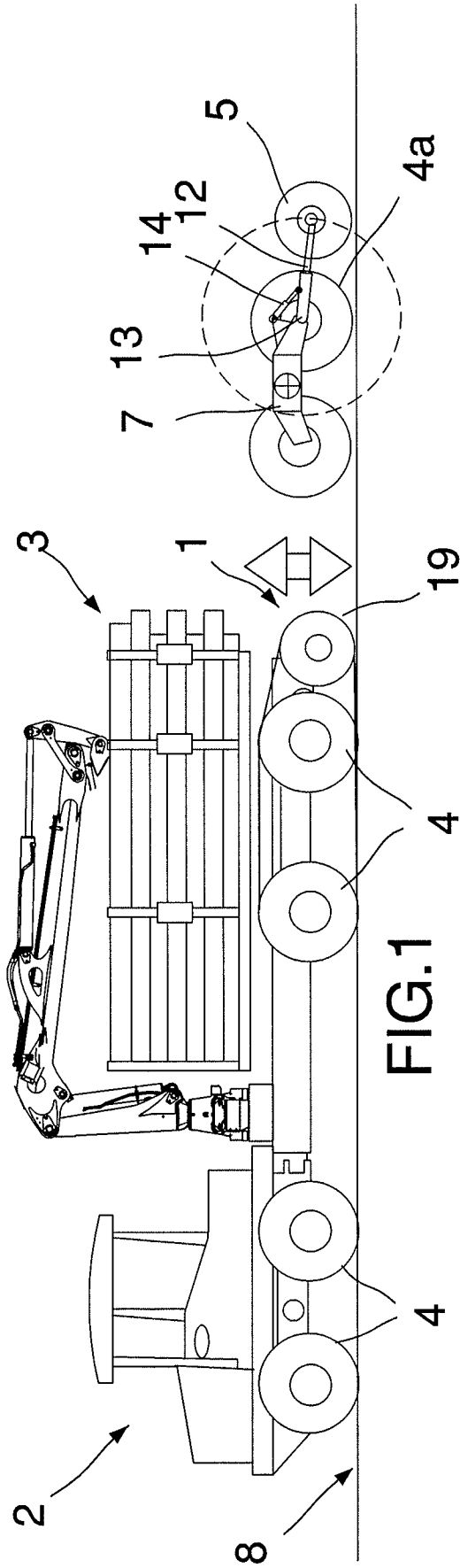

FIG. 1

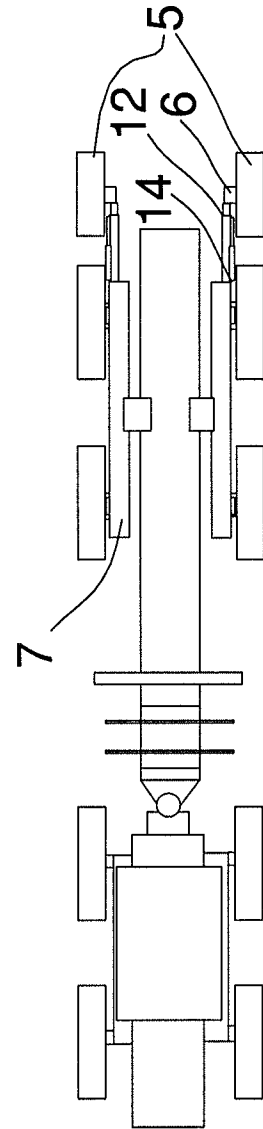

FIG. 2

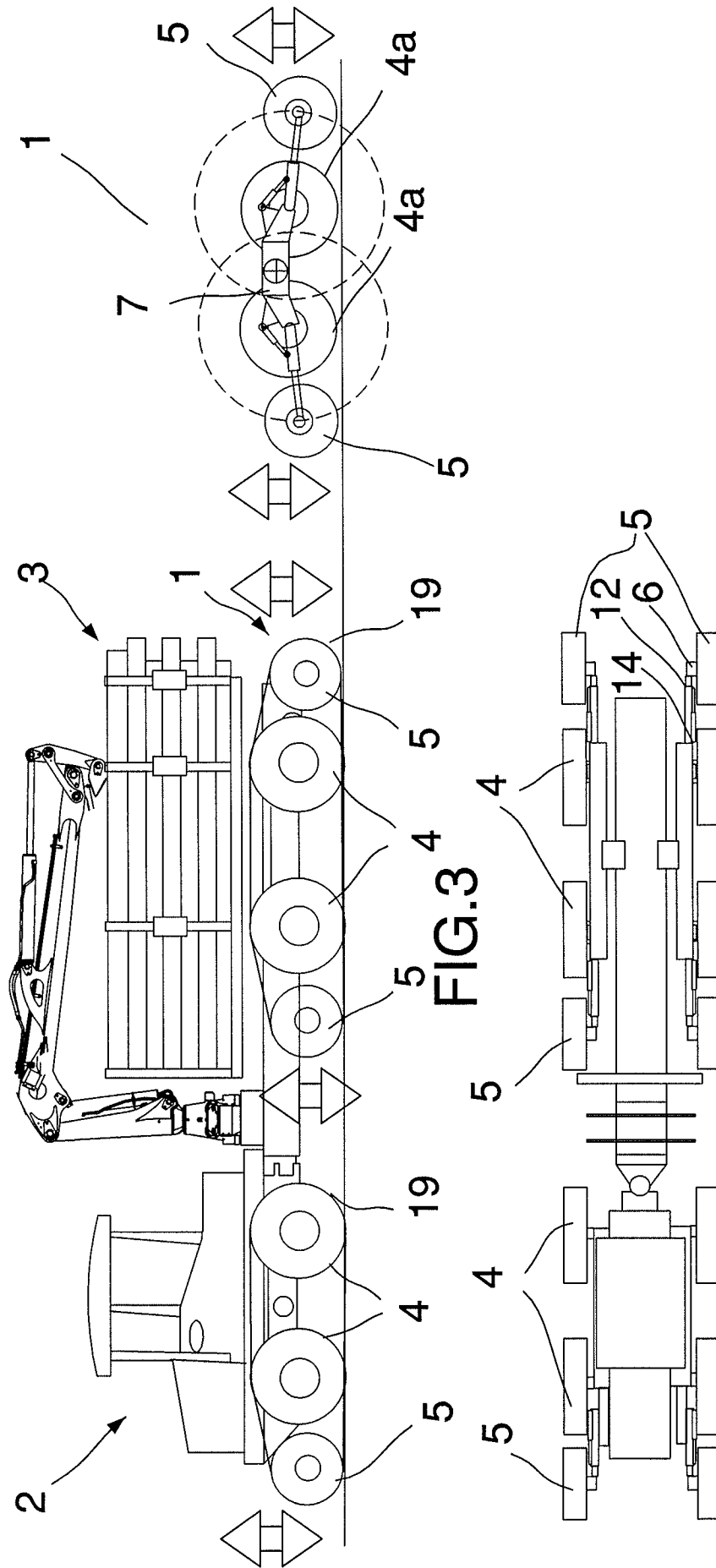
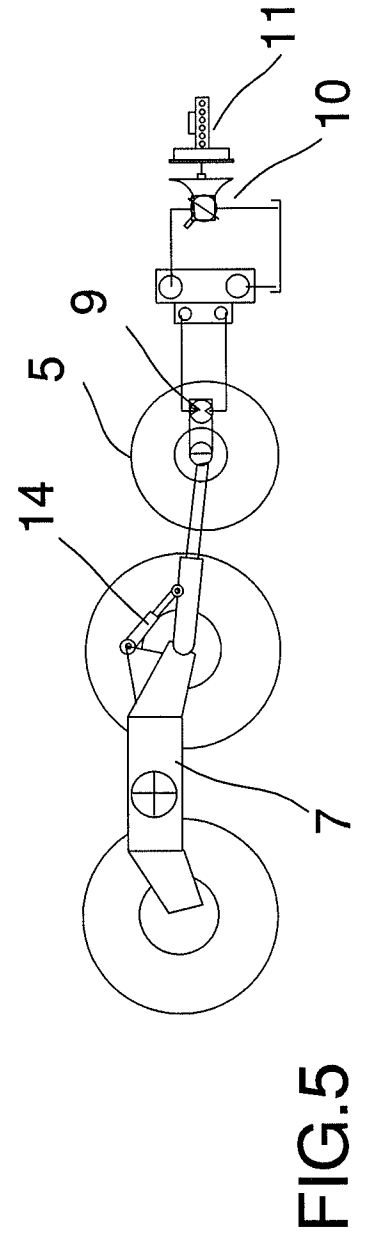
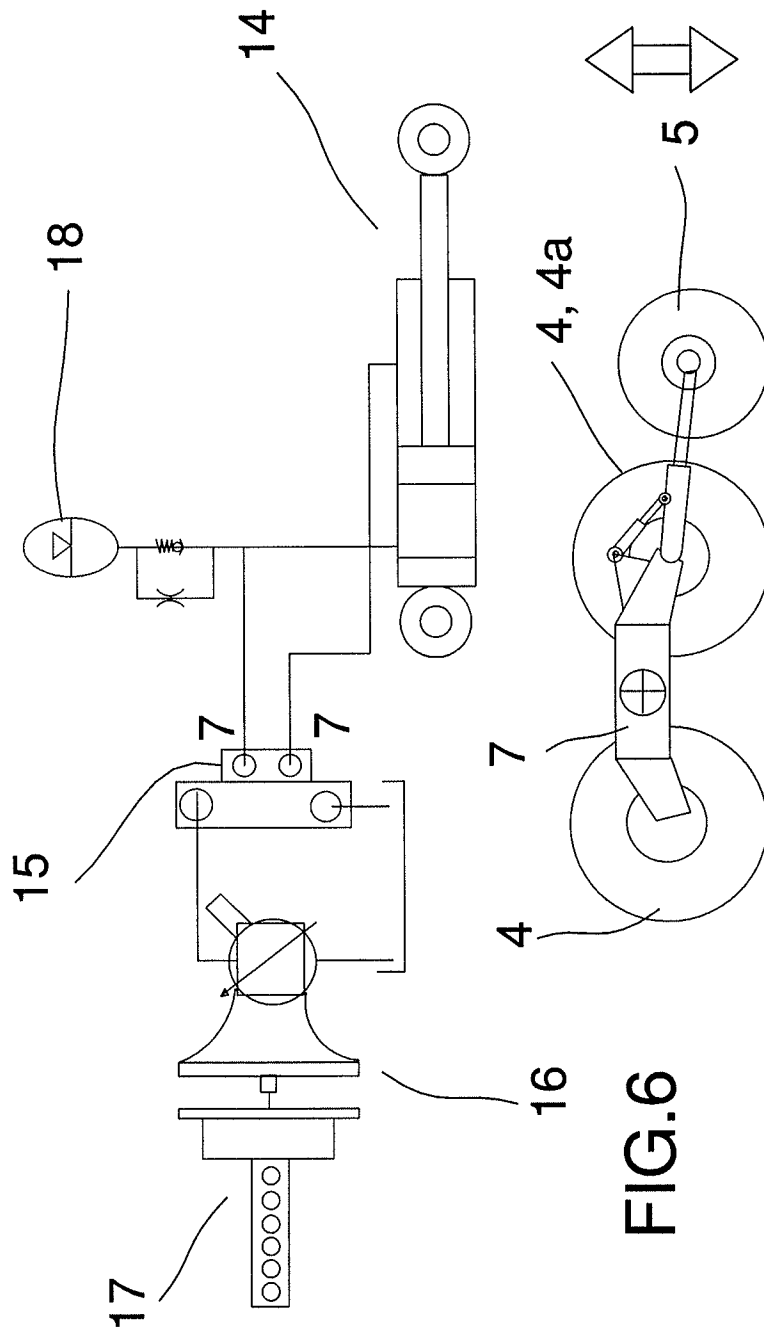

FIG.3

FIG.4



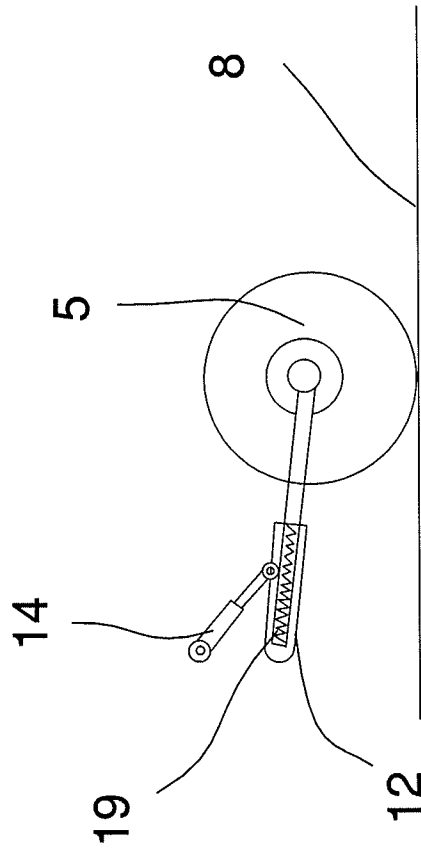

FIG.7

INTERNATIONAL SEARCH REPORT

International application No.
PCT/SE2016/050569

A. CLASSIFICATION OF SUBJECT MATTER		
IPC: see extra sheet		
According to International Patent Classification (IPC) or to both national classification and IPC		
B. FIELDS SEARCHED		
Minimum documentation searched (classification system followed by classification symbols)		
IPC: B62D		
Documentation searched other than minimum documentation to the extent that such documents are included in the fields searched		
SE, DK, FI, NO classes as above		
Electronic data base consulted during the international search (name of data base and, where practicable, search terms used)		
EPO-Internal, PAJ, WPI data		
C. DOCUMENTS CONSIDERED TO BE RELEVANT		
Category*	Citation of document, with indication, where appropriate, of the relevant passages	Relevant to claim No.
A	FI 20070824 A (KARELIAN PUU JA METALLI OY), 8 May 2009 (2009-05-08); abstract; figure 1 --	1-18
A	WO 2013178882 A1 (PONSSE OYJ), 5 December 2013 (2013-12-05); abstract; figures 1,2b --	1-18
A	US 4079798 A (FERRIS TOM), 21 March 1978 (1978-03-21); abstract; column 3, line 13 - line 17; column 3, line 60 - line 62; figures 2,3 --	1-18
A	US 4657099 A (BALTENSBERGER EDUARD), 14 April 1987 (1987-04-14); column 2, line 56 - line 61; figures --	1-18
<input checked="" type="checkbox"/> Further documents are listed in the continuation of Box C. <input checked="" type="checkbox"/> See patent family annex.		
* Special categories of cited documents: "A" document defining the general state of the art which is not considered to be of particular relevance "E" earlier application or patent but published on or after the international filing date "L" document which may throw doubts on priority claim(s) or which is cited to establish the publication date of another citation or other special reason (as specified) "O" document referring to an oral disclosure, use, exhibition or other means "P" document published prior to the international filing date but later than the priority date claimed "T" later document published after the international filing date or priority date and not in conflict with the application but cited to understand the principle or theory underlying the invention "X" document of particular relevance; the claimed invention cannot be considered novel or cannot be considered to involve an inventive step when the document is taken alone "Y" document of particular relevance; the claimed invention cannot be considered to involve an inventive step when the document is combined with one or more other such documents, such combination being obvious to a person skilled in the art "&" document member of the same patent family		
Date of the actual completion of the international search 24-08-2016		Date of mailing of the international search report 31-08-2016
Name and mailing address of the ISA/SE Patent- och registreringsverket Box 5055 S-102 42 STOCKHOLM Facsimile No. + 46 8 666 02 86		Authorized officer Göran Carlström Telephone No. + 46 8 782 28 00

INTERNATIONAL SEARCH REPORT

International application No.
PCT/SE2016/050569

C (Continuation). DOCUMENTS CONSIDERED TO BE RELEVANT		
Category*	Citation of document, with indication, where appropriate, of the relevant passages	Relevant to claim No.
A	US 2974976 A (LYALL RALPH G), 14 March 1961 (1961-03-14); column 3, line 42 - line 74; figures -- -----	1-18

Continuation of: second sheet

International Patent Classification (IPC)

B62D 61/12 (2006.01)

B62D 55/02 (2006.01)

INTERNATIONAL SEARCH REPORT

Information on patent family members

International application No.

PCT/SE2016/050569

FI	20070824 A	08/05/2009	NONE		
WO	2013178882 A1	05/12/2013	CA	2873595 A1	05/12/2013
			CN	104363754 A	18/02/2015
			DE	212013000022 U1	28/05/2014
			EP	2854510 A4	09/03/2016
			FI	124889 B	13/03/2015
			FI	20125597 A	01/12/2013
			US	20150083504 A1	26/03/2015
US	4079798 A	21/03/1978	NONE		
US	4657099 A	14/04/1987	AR	242537 A1	30/04/1993
			AT	58510 T	15/12/1990
			BR	8503187 A	25/03/1986
			CA	1241682 A	06/09/1988
			CH	663936 A5	29/01/1988
			CS	258471 B2	16/08/1988
			CS	8505068 A2	15/01/1988
			DD	241718 A5	24/12/1986
			DE	3580621 D1	03/01/1991
			EP	0167077 A2	08/01/1986
			ES	8607147 A1	01/11/1986
			IN	163528 B	08/10/1988
			JP	6157473 A	24/03/1986
			KR	930000709 B1	30/01/1993
			PL	254369 A1	17/06/1986
			PL	158964 B1	30/10/1992
			RO	93180 B	02/05/1988
			ZA	8505085 B	26/02/1986
US	2974976 A	14/03/1961	NONE		