



(86) Date de dépôt PCT/PCT Filing Date: 2012/09/10  
 (87) Date publication PCT/PCT Publication Date: 2013/03/21  
 (85) Entrée phase nationale/National Entry: 2014/02/28  
 (86) N° demande PCT/PCT Application No.: SE 2012/050951  
 (87) N° publication PCT/PCT Publication No.: 2013/039443  
 (30) Priorité/Priority: 2011/09/13 (SE1150824-9)

(51) Cl.Int./Int.Cl. *H02K 11/00* (2006.01),  
*B63H 23/34* (2006.01), *F16C 3/02* (2006.01)  
 (71) Demandeur/Applicant:  
ROLLS-ROYCE AB, SE  
 (72) Inventeurs/Inventors:  
ERIKSSON, ANDREAS, SE;  
LOBELL, ANDERS, SE;  
NAHNFELDT, PER, SE;  
STYRUD, GUNNAR, SE  
 (74) Agent: BORDEN LADNER GERVAIS LLP

(54) Titre : PROCÉDE ET DISPOSITIF PERMETTANT DE PROTÉGER LE MOTEUR D'UNE NACELLE CONTRE LES  
CHOCs PLIANT L'ARBRE  
 (54) Title: A METHOD OF AND A DEVICE FOR PROTECTING A MOTOR IN A POD AGAINST SHAFT BENDING  
SHOCKS

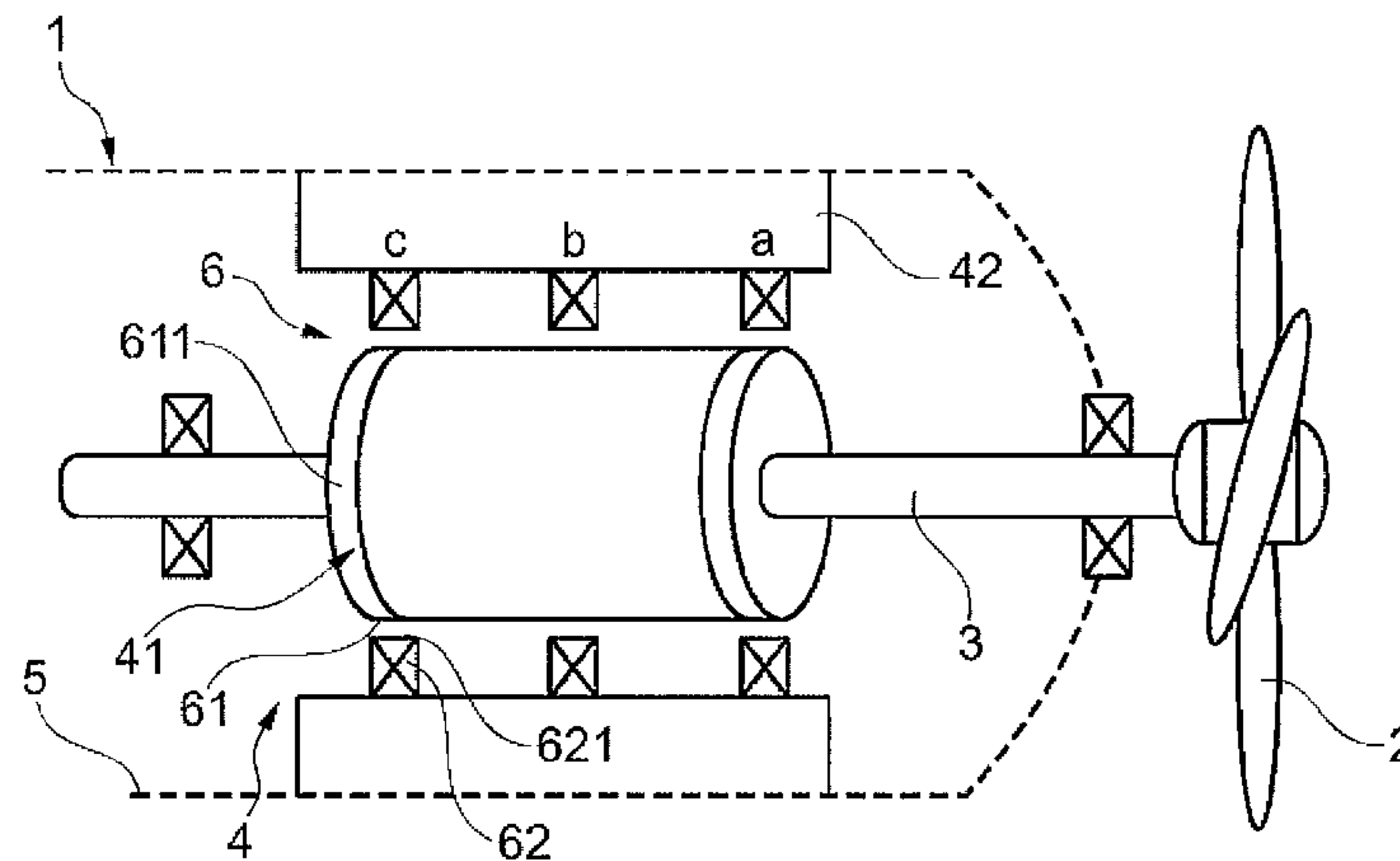

Fig. 1

(57) **Abrégé/Abstract:**

A method of and a device for protecting an electric motor (4) in a pod unit (1) for propulsion of marine vessels against shaft bending shocks when the blades (2) of the pod propeller hit ice blocks or other hard objects, said motor (4) having a drive shaft (3), a rotor (41) and a stator (42), said shocks tending to momentarily bend the drive shaft (3) to such an extent that the rotor (41) will come into contact with the stator (42). In accordance with the present invention, the rotor (41) is prevented from coming in detrimental contact with the stator (42) by providing at least two members (61, 62), which together form a radial plain bearing (6) having mating arcuate bearing surfaces (611 and 621, respectively), which during normal operation of the motor (4) are spaced from one another by a gap and come in contact with one another only at extreme loads with short durations. One of the members (61, 62) is an inner member (61) having a circular circumference that constitutes one (611) of the bearing surfaces (611, 621). The arcuate bearing surface (611) of the inner member (61) is coaxial with the rotor (41) and rotary therewith, and at least one of the other members is an outer member (62), which fixed in relation to the stator (42) and has its arcuate bearing surface (621) coaxial therewith.



(12) INTERNATIONAL APPLICATION PUBLISHED UNDER THE PATENT COOPERATION TREATY (PCT)

(19) World Intellectual Property  
Organization  
International Bureau(10) International Publication Number  
**WO 2013/039443 A1**(43) International Publication Date  
21 March 2013 (21.03.2013)

- (51) **International Patent Classification:**  
*H02K 11/00* (2006.01)     *F16C 3/02* (2006.01)  
*B63H 23/34* (2006.01)
- (21) **International Application Number:**  
PCT/SE2012/050951
- (22) **International Filing Date:**  
10 September 2012 (10.09.2012)
- (25) **Filing Language:** English
- (26) **Publication Language:** English
- (30) **Priority Data:**  
1150824-9    13 September 2011 (13.09.2011)     SE
- (71) **Applicant (for all designated States except US):** **ROLLS-ROYCE AB** [SE/SE]; P. O. Box 1010, S-681 29 Kristinehamn (SE).
- (72) **Inventors; and**
- (75) **Inventors/Applicants (for US only):** **ERIKSSON, Andreas** [SE/SE]; Fallvägen 19, S-663 40 Hammarö (SE). **LOBELL, Anders** [SE/SE]; Spelgatan 25, S-691 36 Karlskoga (SE). **NAHNFELDT, Per** [SE/SE]; Bondegatan 3, S-654 65 Karlstad (SE). **STYRUD, Gunnar** [SE/SE]; Sandtorpsvägen 13, S-681 52 Kristinehamn (SE).
- (74) **Agent:** **HYNELL PATENTTJÄNST AB**; P.O. Box 138, S-683 23 Hagfors (SE).
- (81) **Designated States (unless otherwise indicated, for every kind of national protection available):** AE, AG, AL, AM, AO, AT, AU, AZ, BA, BB, BG, BH, BN, BR, BW, BY, BZ, CA, CH, CL, CN, CO, CR, CU, CZ, DE, DK, DM, DO, DZ, EC, EE, EG, ES, FI, GB, GD, GE, GH, GM, GT, HN, HR, HU, ID, IL, IN, IS, JP, KE, KG, KM, KN, KP, KR, KZ, LA, LC, LK, LR, LS, LT, LU, LY, MA, MD, ME, MG, MK, MN, MW, MX, MY, MZ, NA, NG, NI, NO, NZ, OM, PA, PE, PG, PH, PL, PT, QA, RO, RS, RU, RW, SC, SD, SE, SG, SK, SL, SM, ST, SV, SY, TH, TJ, TM, TN, TR, TT, TZ, UA, UG, US, UZ, VC, VN, ZA, ZM, ZW.
- (84) **Designated States (unless otherwise indicated, for every kind of regional protection available):** ARIPO (BW, GH, GM, KE, LR, LS, MW, MZ, NA, RW, SD, SL, SZ, TZ, UG, ZM, ZW), Eurasian (AM, AZ, BY, KG, KZ, RU, TJ, TM), European (AL, AT, BE, BG, CH, CY, CZ, DE, DK, EE, ES, FI, FR, GB, GR, HR, HU, IE, IS, IT, LT, LU, LV, MC, MK, MT, NL, NO, PL, PT, RO, RS, SE, SI, SK, SM, TR), OAPI (BF, BJ, CF, CG, CI, CM, GA, GN, GQ, GW, ML, MR, NE, SN, TD, TG).

**Published:**

— with international search report (Art. 21(3))

(54) **Title:** A METHOD OF AND A DEVICE FOR PROTECTING A MOTOR IN A POD AGAINST SHAFT BENDING SHOCKS

Fig. 1

(57) **Abstract:** A method of and a device for protecting an electric motor (4) in a pod unit (1) for propulsion of marine vessels against shaft bending shocks when the blades (2) of the pod propeller hit ice blocks or other hard objects, said motor (4) having a drive shaft (3), a rotor (41) and a stator (42), said shocks tending to momentarily bend the drive shaft (3) to such an extent that the rotor (41) will come into contact with the stator (42). In accordance with the present invention, the rotor (41) is prevented from coming in detrimental contact with the stator (42) by providing at least two members (61, 62), which together form a radial plain bearing (6) having mating arcuate bearing surfaces (611 and 621, respectively), which during normal operation of the motor (4) are spaced from one another by a gap and come in contact with one another only at extreme loads with short durations. One of the members (61, 62) is an inner member (61) having a circular circumference that constitutes one (611) of the bearing surfaces (611, 621). The arcuate bearing surface (611) of the inner member (61) is coaxial with the rotor (41) and rotary therewith, and at least one of the other members is an outer member (62), which fixed in relation to the stator (42) and has its arcuate bearing surface (621) coaxial there-with.

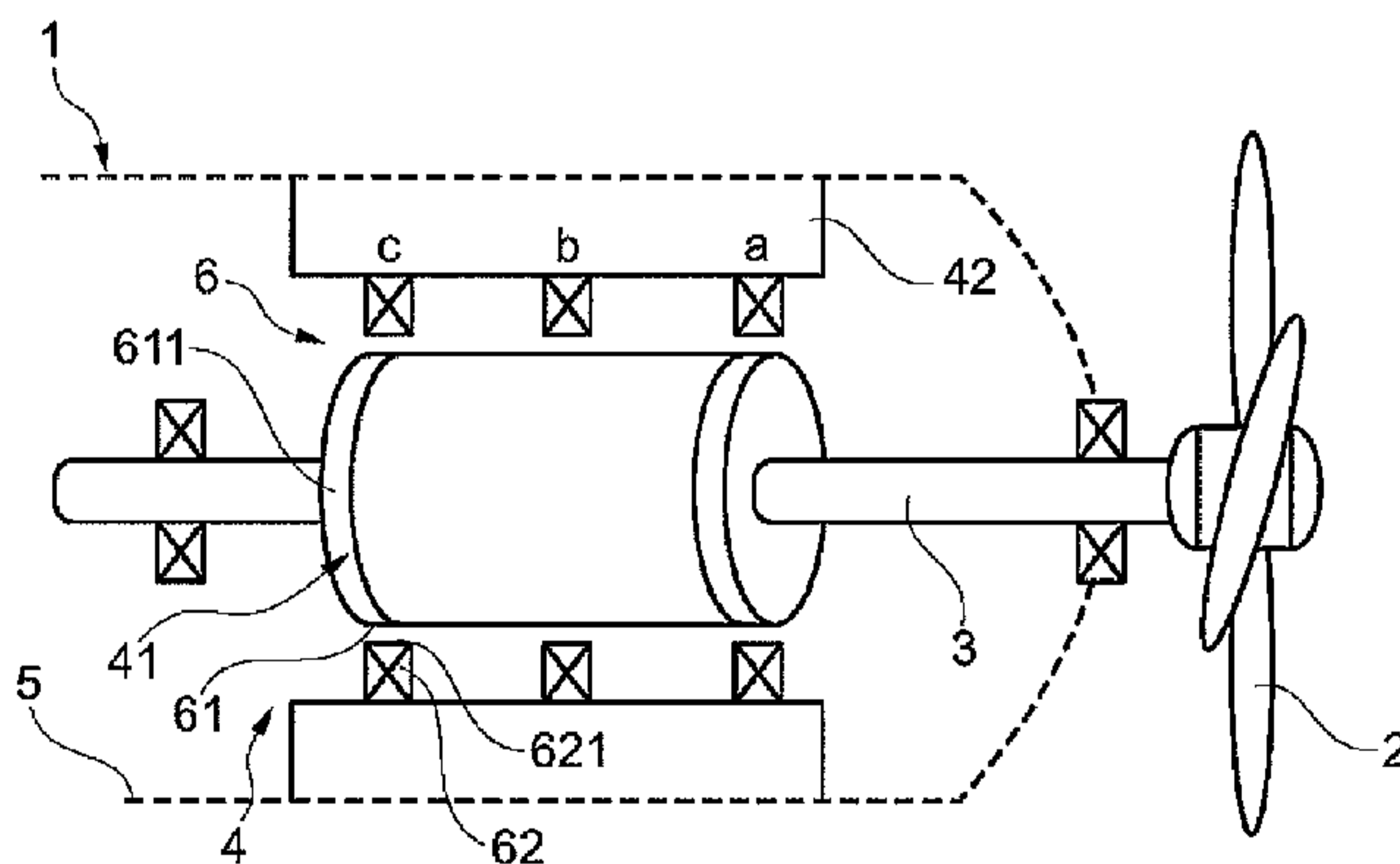

WO 2013/039443 A1

## A METHOD OF AND A DEVICE FOR PROTECTING A MOTOR IN A POD AGAINST SHAFT BENDING SHOCKS

### 5 TECHNICAL FIELD

The present invention relates to a method of and a device for protecting an electric motor in a pod unit for propulsion of marine vessels against shaft bending shocks when the blades of the pod propeller hit ice blocks or other hard objects, said motor having a drive shaft, a rotor and a stator, said shocks tending to momentarily bend the drive shaft  
10 to such an extent that the rotor will come into contact with the stator.

### BACKGROUND ART

When operating pod units in arctic seas, very stiff propeller blades are required. This means that also a very stiff shaft is required in order to avoid that the motor inside the  
15 pod is damaged in case the propeller hits ice or some other hard object, *e.g.* is grounded, whereby the shaft will be exposed to a bending force.

Another situation that could cause high bending forces (and risk of damaging the motor) would be when high shock loads are encountered, *e.g.* due to an explosion of a mine. As  
20 a consequence this might be required as a dimensioning criterion for certain projects, *e.g.* for navy vessels.

To avoid a detrimental bending of the shaft, it would be obvious to use a very stiff shaft. However, this means that that shaft would have to have a very large diameter, which is  
25 costly, increases the weight of the pod unit and further requires space that not always is available.

WO 2010/108544 A2 discloses a bearing assembly for an electrical motor, comprising a shaft, a housing, and a main bearing between the shaft and the housing, wherein the  
30 shaft is surrounded by a rigid sleeve for functioning as an auxiliary bearing in case of a breakdown of the main bearing and as a grease sealing under normal operation. The clearance between the sleeve and the shaft is smaller than the air-gap between the stator and the rotor of the motor. The clearance is at most 0.6 mm but may be at most 0.3, 0.2, 0.1 or 0.05 mm, while the air-gap between the stator and the rotor typically is 1.2–1.5  
35 mm. With reference to the interior of the pod housing, the sleeve is shown positioned just inside the main bearing. There is no indication that such an arrangement would

make it possible to reduce the required diameter of the shaft, *i.e.* to use a weaker shaft than else would be possible.

#### SUMMARY OF THE INVENTION

- 5 The object of the present invention is to protect the motor without having to over-dimension the shaft.

In accordance with the present invention, this object is achieved in that at least two members are provided, which together form a radial plain bearing having mating  
10 arcuate bearing surfaces, which during normal operation of the motor are spaced from one another by a gap and come in contact with one another only at extreme loads with short durations, one of the members being an inner member having a circular circumference constituting one of the bearing surfaces, said inner member having its arcuate bearing surface coaxial with the rotor and rotary therewith, and at least one of  
15 the other members being an outer member, which fixed in relation to the stator and has its arcuate bearing surface coaxial therewith.

When the blades of the pod propeller hit ice blocks or other hard objects, and the arising extreme loads with short durations bend of the drive shaft to such an extent that the  
20 rotor will tend to come into detrimental contact with the stator, the detrimental contact is prevented in that the inner member of the radial bearing will bear against the outer member(s). Similarly, if a chock load hits the POD the invention may safeguard functioning of the motor by eliminating detrimental contact between stator and rotor.

25 Suitably, one of the at least two members consists of a softer material than the other. Furthermore it is mostly preferred to design the members of the invention to not allow electrical conduction, e.g. by using non-conductive material in at least one of the members. Most preferred the softer material is non-conductive to electricity. Thereby, when the bearing surfaces are in contact with each other, no conductive material will  
30 come loose and be spread inside the pod where it might harm the motor or other components.

The softer material preferably is used for the outer member(s). Then, the stator includes windings, and segments of the softer material are fitted between or on top of the  
35 windings of the stator. Alternatively, the softer material is fitted as a band on the inner surface of the stator.

As another alternative, the stator is fixed in a pod housing and the member of softer material is fixed to the housing.

When one of the at least two members consists of a softer material, the other of the at least two members consists of a harder material. Suitably, the harder material is used for the inner member, and the inner member is a ring.

Preferably, the rotor includes windings, and the ring of the harder material is either provided on top of the windings of the rotor or is an integrated part of the rotor or a non-integrated part at the end of the rotor.

Alternatively, the ring of the harder material is a dedicated device on the shaft line, such as a brake disc, or a member of the shaft itself, e.g. a flange.

#### 15 BRIEF DESCRIPTION OF THE DRAWINGS

In the following, the invention will be described in more detail with reference to preferred embodiments and the appended drawings.

Fig. 1 is a sketchy partial cross-sectional view of a portion of a pod unit in accordance with a first embodiment of the present invention.

Figs. 2a to 2c are schematic cross-sectional views of three different embodiments of a motor in the pod unit of Fig. 1.

Fig. 3 is a sketchy partial cross-sectional view of a portion of a pod unit in accordance with another embodiment of the present invention.

25

#### MODE(S) FOR CARRYING OUT THE INVENTION

Fig. 1 shows a portion of a pod unit 1 for propulsion of a marine vessel in arctic seas, where the propeller blades 2 of the pod unit may hit ice or other hard objects or be grounded. In addition to the propeller, the pod unit 1 comprises a stiff drive shaft 3 connecting an electric motor 4 to the propeller. The motor 4 is placed inside a housing 5 and comprises a rotor 41 and a schematically shown stator 42. The rotor 41 and the shaft 3 form an assembly that is carried in bearings. When the propeller blades 2 hit ice or some other hard object, a high shock load is encountered, which tends to momentarily bend the rotor shaft assembly, so that the rotor 41 may come into contact with the stator 42 and damage the motor 4 unless prevented from doing so.

30  
35

In accordance with the present invention, the rotor 41 is prevented from coming in detrimental contact with the stator 42 by providing at least two members 61, 62, which together form a radial plain bearing 6 having mating arcuate bearing surfaces 611 and 621, respectively, which during normal operation of the motor 4 are spaced from one another by a non-conductive gap, e.g. a gas gap, preferably an air gap, and come in contact with one another only at extreme loads with short durations. One of the members 61, 62 is an inner member 61 having a circular circumference that constitutes one 611 of the bearing surfaces 611, 621. The arcuate bearing surface 611 of the inner member 61 is coaxial with the rotor 41 and rotary therewith, and at least one of the other members is an outer member 62, which is fixed in relation to the stator 42 and has its arcuate bearing surface 621 coaxial therewith.

When the propeller blades 2 hit ice blocks or other hard objects, and the arising extreme loads with short durations bend the rotor shaft assembly to such an extent that the rotor 41 will tend to come into detrimental contact with the stator 42, the detrimental contact is prevented in that the inner member 61 of the radial plain bearing 6 will bear against the outer member(s) 62.

The radial plain bearing 6 may be located at any axial location along the shaft rotor assembly (between positions *a* and *c* in Fig. 1), but for maintenance purposes it is best to locate it at an end of the motor 4. Usually, it is preferred to locate it at the end closest to the propeller (at position *a* in Fig. 1), where also the bending of the shaft will be at a maximum. In case the loading condition is not bending but shock loads, it may be preferable to provide two radial plain bearings located at positions *a* and *c* in Fig. 1.

Suitably, one of the at least two members 61, 62 consists of a softer material than the other, and the softer material is non-conductive to electricity. Thereby, when the bearing surfaces 611 and 621 are in contact with each other, no conductive material will come loose from the softer bearing surface and be spread inside the pod 1 where it might harm the motor 4 or other components.

The softer material preferably is used for the outer member(s) 62. The stator 42 includes windings 421, and segments 622 of the softer material are fitted between the windings 421 of the stator 42 as shown in Fig. 2a or on top of the windings 421 of the stator 42 as shown in Fig. 2b. Alternatively, the softer material is fitted as a circumferential band 623 on the inner surface of the stator 42 as shown in Fig. 2c. Then, the radial plain

bearing 6 is formed by two complete rings 61 and 623 instead of one ring 61 and a plurality of ring segments 62.

As another alternative, not shown, the member 62 of softer material is fixed to the pod housing 5.

It is easily realized that when one 62 of the at least two members 61, 62 consists of a softer material, the other one 61 of the at least two members 61, 62 consists of a harder material. Suitably, the harder material is used for the inner member 61, and the inner member is a ring 61.

Preferably, the rotor 41 includes windings 411, and the ring 61 of the harder material is either provided on top of the windings 411 of the rotor 41 or is an integrated part of the rotor 41, or a ring (or two, or more) at an end of the rotor.

Alternatively, the ring 61 of the harder material is a dedicated device of the motor 4 or the shaft 3 fitted there for another main purpose, such as a brake disc, as is shown in Fig. 3. The ring 61 may be a solid disc or a ring attached to the shaft 3, by means of spokes or the like. The outer member 62 may be fixedly attached to a fixed part of the motor 4, e.g. forming the inner surface of a part of a housing (not shown), or fixed to the POD-housing (directly or indirectly, not shown).

The ring 61 may also be arranged on the periphery of a flange coupling (not shown) of the shaft 3. If desired, it is possible to let the ring 61 and the ring segments 62 change places, so that the ring segments 62 are provided on the rotor 41 and the ring 61 is provided on the stator 42. It is also possible, if desired, to use the harder material for the bearing member(s) provided on the stator 42 and the softer material for the bearing member(s) provided on the rotor 41.

The above detailed description is primarily intended only to facilitate the understanding of the invention, and any unnecessary limitations shall not be interpreted therefrom. Modifications, which during a study of the description become obvious to a person skilled in the art, may be made without any deviations from the inventive idea or the scope of the appended claims, e.g. it is evident that also bearing members of the same material/hardness may be used. Similarly it is evident that also conductive members may be used to fulfill the basic function of the invention.

**INDUSTRIAL APPLICABILITY**

The present invention is applicable for preventing detrimental contact between rotor and stator in a pod motor for a marine vessel for use in arctic seas, where the pod propeller may hit ice blocks or other hard object, thereby creating shocks that will tend to

5 momentarily bend the pod shaft.

## CLAIMS

1. A method of protecting an electric motor (4) in a pod unit (1) for propulsion of marine vessels against shaft bending shocks e.g. when the blades (2) of the pod propeller hit ice blocks or other hard objects, said motor (4) having a drive shaft (3),  
5 a rotor (41) and a stator (42), said shocks tending to momentarily bend the drive shaft (3) to such an extent that the rotor (41) may come into contact with the stator (42), said method comprising:  
providing at least two members (61, 62), which together form a radial plain bearing (6) having mating arcuate bearing surfaces (611 and 621, respectively), which  
10 during normal operation of the motor (4) are spaced from one another by a non-conductive gap and come in contact with one another only at extreme loads with short durations.
2. A method as claimed in claim 1, wherein that one (61) of the members (61, 62)  
15 being an inner member having a circular circumference constituting one (611) of the bearing surfaces (611, 621), said inner member (61) having its arcuate bearing surface (611) coaxial with the rotor (41) and rotary therewith, and at least one (62) of the other members being an outer member, which is fixed in relation to the stator (42) and also has its arcuate bearing surface (621) coaxial with the rotor (41).  
20
3. A method as claimed in claim 2, wherein one (62) of the at least two members (61, 62) consists of a softer material than the other, and said softer material is non-conductive to electricity.
- 25 4. A method as claimed in claim 3, wherein the softer material is used for the outer member(s) (62).
- 5 A method as claimed in claim 4, wherein that said outer member (62) comprising a plurality of segments (622).  
30
6. A method as claimed in claim 5, wherein the stator (42) includes windings (421), and said segments (622) of the softer material are fitted between or on top of the windings (421) of the stator (42).
- 35 7. A method as claimed in claim 4, wherein the softer material is fitted as a circumferential band (623) on the inner surface of the stator (42).

8. A method as claimed in claim 4 or 5, wherein the inner member (61) is a ring.
9. A method as claimed in claim 8, wherein the rotor (41) includes windings (411), and the ring (61) of the harder material is provided on top of the windings (411) of the rotor (41).  
5
10. A method as claimed in claim 8, wherein the ring (61) of the harder material is an integrated part of the rotor (41), wherein preferably the motor (4) is an induction motor.  
10
11. A method as claimed in claim 8, wherein the ring (61) of the harder material is arranged on a dedicated device (7) of the motor (4), such as a brake disc.
12. A device for protecting an electric motor (4) in a pod unit (1) for propulsion of marine vessels against shaft bending shocks, e.g. when the blades (2) of the pod propeller hit ice blocks or other hard objects, said motor (4) having a drive shaft (3), a rotor (41) and a stator (42), said shocks tending to momentarily bend the drive shaft (3) to such an extent that the rotor (41) may come into contact with the stator (42), said device comprising:  
15  
20 at least two members (61, 62), which together form a radial plain bearing (6) having mating arcuate bearing surfaces (611 and 621, respectively) that during normal operation of the motor (4) are spaced from one another by a gas gap and come in contact with one another only at extreme loads with short durations.
- 25 13. A device as claimed in claim 12, wherein one (61) of the members (61, 62) being an inner member having a circular circumference constituting one (611) of the bearing surfaces (611, 621), said inner member (61) having its arcuate bearing surface (611) coaxial with the rotor (41) and rotary therewith, and at least one (62) of the other members being an outer member, which fixed in relation to the stator (42) and has its arcuate bearing surface (621) coaxial with the rotor (41).  
30
14. A device as claimed in claim 12, wherein one (62) of the at least two members (61, 62) consists of a softer material than the other, and said softer material is non-conductive to electricity.  
35
15. A device as claimed in claim 14, wherein the softer material is used for the outer member(s) (62).

16. A device as claimed in claim 15, wherein that said outer member (62) comprising a plurality of segments (622).
- 5 17. A device as claimed in claim 16, wherein the stator (42) includes windings (421), and segments (622) of the softer material are fitted between or on top of the windings (421) of the stator (42).
- 10 18. A device as claimed in claim 15, wherein the softer material is fitted as a circumferential band (623) on the inner surface of the stator (42).
19. A device as claimed in claim 15 or 16, wherein the harder material is used for the inner member (61), and the inner member (61) is a ring.
- 15 20. A device as claimed in claim 19, wherein the rotor (41) includes windings (411), and the ring (61) of the harder material is provided on top of the windings (411) of the rotor (41).
- 20 21. A device as claimed in claim 19, wherein the ring (61) of the harder material is an integrated part of the rotor (41), wherein preferably the motor (4) is an induction motor having a slip ring rotor, and the integrated part is a slip ring of the rotor.
- 25 22. A device as claimed in claim 20, wherein the ring (61) of the harder material is arranged on a dedicated device (7) of the motor (4), such as a brake disc.

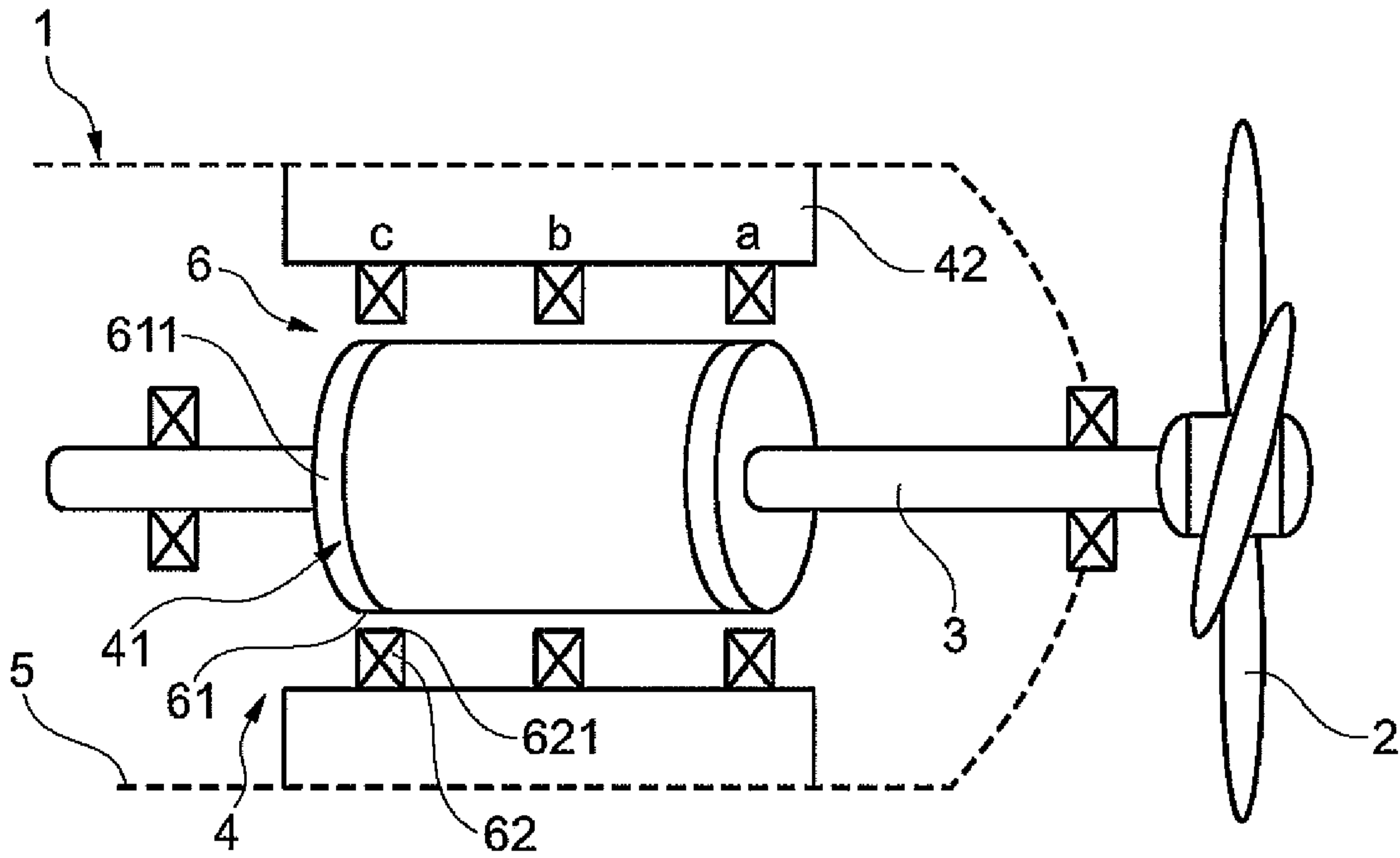

Fig. 1

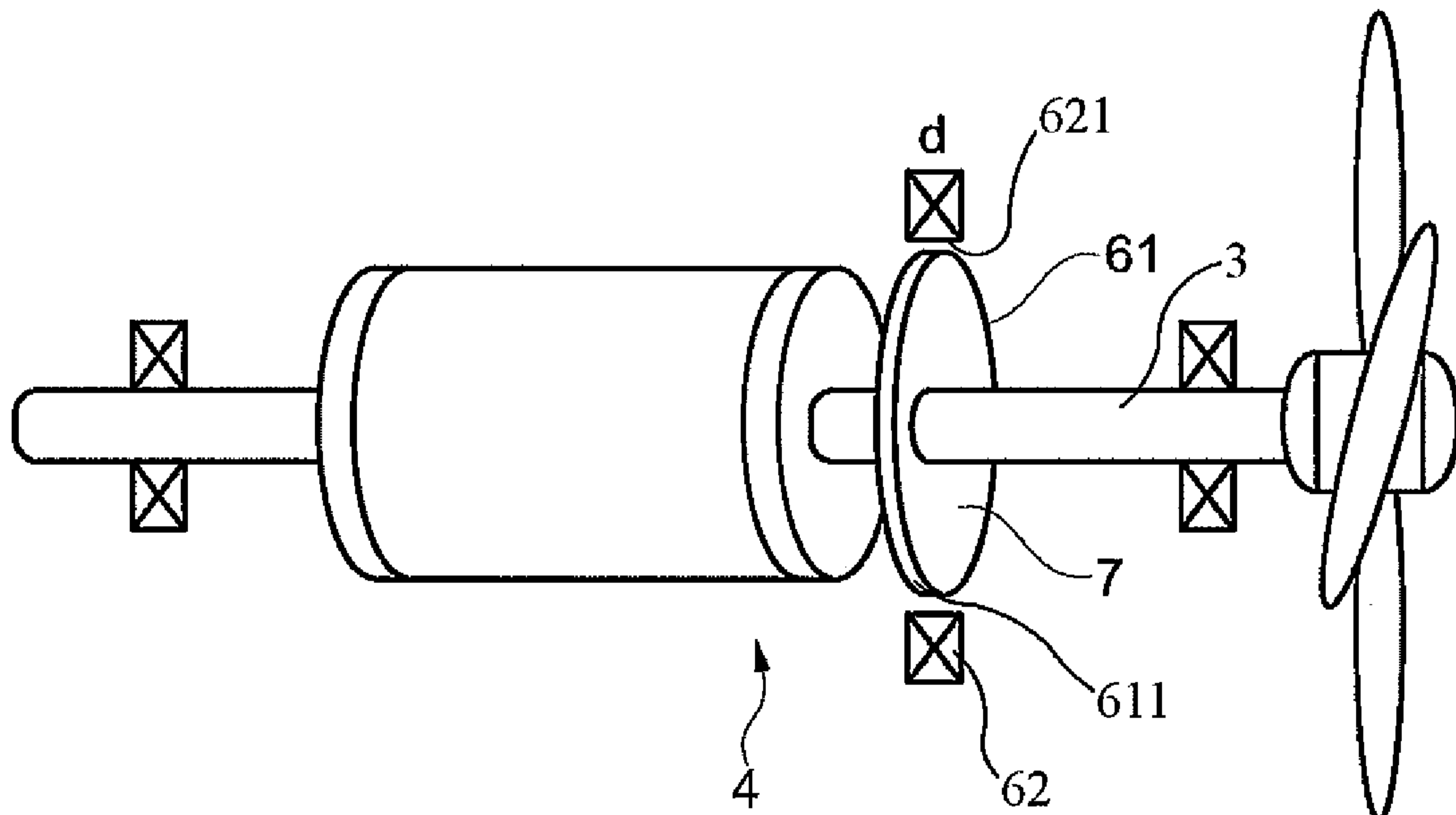

Fig. 3

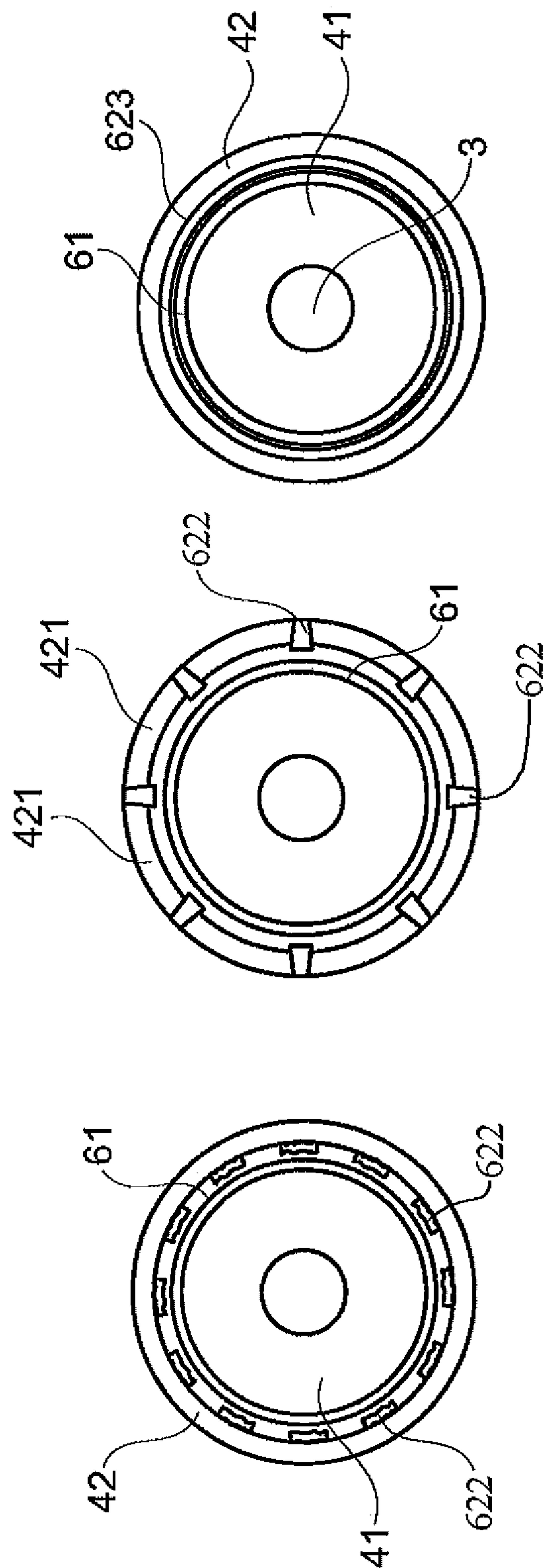

Fig. 2c

Fig. 2a

Fig. 2b

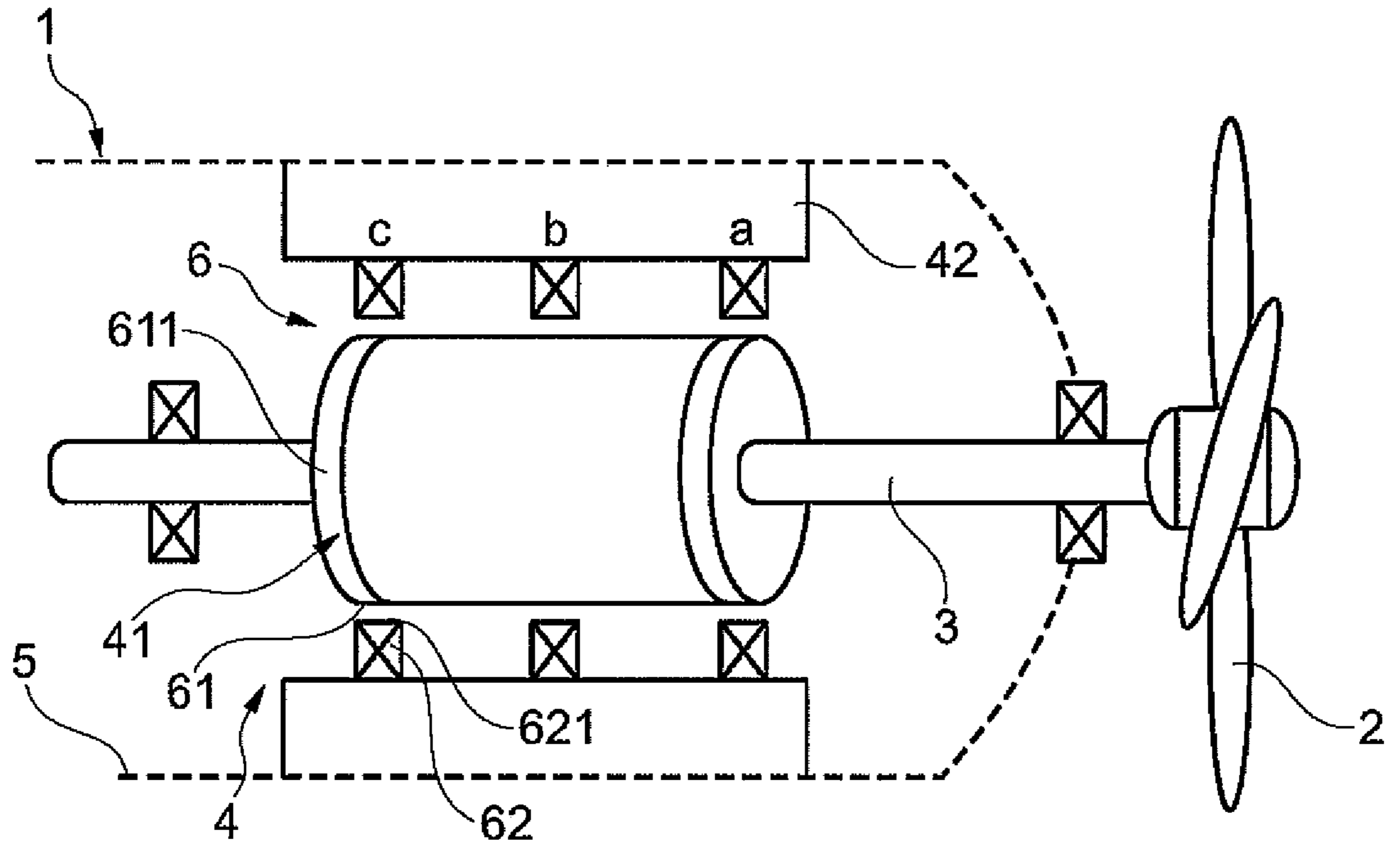

Fig. 1